

# C-Class Coupé



Mercedes-Benz





# First impressions

On the outside, it's a dynamic coupé whose looks never fail to cause a stir. Inside, however, it's an oasis of calm, a place to relax and enjoy every bend and straight in total comfort. It's the C-Class Coupé, a winning combination of luxury, personality and driving pleasure.

With efficiently powerful engines, ECO start/stop, Agility Control suspension and standard-setting safety technology.

[Overview](#) | [from page 4](#)   [Insights](#) | [from page 11](#)

## Featured models:

**C 350 BlueEFFICIENCY AMG Sport | Palladium Silver metallic** |  
front page and page 2

AMG alloy wheels in 7-spoke design, Flamenco Red leather, dark brushed aluminium trim

**C 250 CDI BlueEFFICIENCY AMG Sport | Diamond White metallic** |  
page 9

AMG alloy wheels in 7-spoke design, Black cloth/Artico artificial leather

Specifications shown may include optional equipment and accessories



With an iPad® you can download the interactive C-Class Coupé brochure app either by scanning the QR code or by visiting the App Store



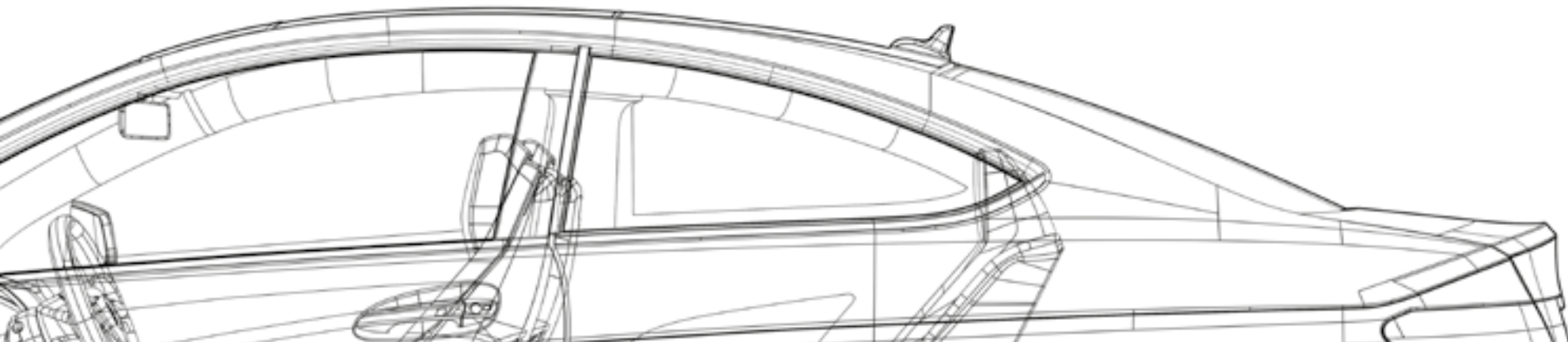

# Facts

**Agile style:** BlueEFFICIENCY, diesel and petrol engines, transmissions, AMG Handling Package

Engines and AMG Handling Package | from page 14

**Integrated safety in the C-Class Coupé:** safer driving, anticipating danger, protecting occupants and post-crash safety.

Safety | from page 20

**Relaxing enjoyment:** multimedia systems, electronic assistants and coupé-specific seats.

Comfort | from page 24

**Adrenalin machine:** the C 63 AMG Coupé, C 63 AMG technology and AMG Performance Studio options.

AMG | from page 30

**Your personal coupé:** standard equipment and optional extras, C-Class Coupé AMG Sport, alloy wheels and Retailer-fit accessories.

Equipment | from page 36

**More Mercedes-Benz:** test drive, Mercedes-Benz Finance and Insurance, Factory Collection, Interactive Owner's Manual, Roadside Assistance and Mercedes-Benz World.

Services | from page 52

**The C-Class Coupé in figures:** dimensions, paint finishes and technical data.

Facts and finishes | from page 54



## Two doors, no compromises: concentrated coupé flair

The stance is low-slung; the face unmistakable, a large three-pointed star dominating its two-bar grille. The rear? Compact, muscular and broad-shouldered. It's a coupé for those who don't stand still.



Care instructions:  
apply regularly to tarmac





C 350





## Having thoughts about the environment? We're with you.

The C-Class Coupé comes with new-generation engines that achieve significant reductions in fuel consumption. What's more, its ECO start/stop function and the optional 7G-Tronic Plus automatic transmission help to improve efficiency even further. Good for your conscience – and for your wallet. → pages 16-18

Welcome to the coupé lounge





Your first Mercedes?  
We promise it won't be your last



## A sixth sense also comes as standard

The C-Class Coupé always seems to know what's just ahead. Its safety systems are constantly evaluating the current situation and anticipating the next, helping you to stay out of danger whenever possible.

The Adaptive Brake System, for instance, can prime the brakes even before you press the pedal, ensuring they react faster – and bring the car to a standstill more quickly.





## Best of breed

A wider and longer chassis, larger tyres, two doors less and an improved safety concept with a carbon-fibre monocoque – that’s the new DTM AMG Mercedes C-Coupe at the beginning of a new era in the DTM (German Touring Car Championship).

The C-Class family can look back on an unparalleled success story. Mercedes-Benz with the help of AMG was runner-up in its first season in 1988 – that was with the 190 E 2.5-16 EVO, the racing version of the famous C-Class predecessor. With 85 victories in 159 races, the C-Class is the most successful car in the 27-year history of the DTM.

Fingers crossed for the DTM AMG Mercedes C-Coupe to be first past the post in the coming season.



**14 BlueEFFICIENCY****15 Efficiency in the C-Class Coupé****16 Diesel engines**

4-cylinder diesel engines

Additional efficiency measures

**17 Petrol engines**

4-cylinder petrol engines

V6 petrol engine

Additional efficiency measures

**18 Transmissions**

6-speed manual transmission

7G-Tronic Plus

**19 AMG Handling Package****20 Integrated safety concept**

Attention Assist

Intelligent Light System

LED tail lights and adaptive brake lights

Driving Assistance Package

Pre-Safe® Brake and BAS Plus

Pre-Safe® system

Neck-Pro active head restraints

Restraint systems

Active Bonnet

Mercedes-Benz Emergency Call System

Post-crash safety

**24 Multimedia systems**

COMAND Online

Harman Kardon® Logic 7®

surround sound system

Audio 20

Becker® Map Pilot navigation system

**26 Electronic assistants**

Speed Limit Assist

Reversing camera

Parktronic with Advanced

Parking Guidance

Lane-Tracking Package

**28 Seats**

Coupé-specific front seats

Individual rear seats with integral

head restraints

Memory Package

**30 C 63 AMG Coupé****32 C 63 AMG technology**

AMG 6.3-litre V8

AMG sports suspension

AMG Speedshift MCT 7-speed

sports transmission

**35 AMG Performance Studio**

36 **Standard equipment**

37 **Optional extras**

38 **AMG Sport model**

40 **AMG Sport Plus model**

42 **Upholstery and trim**

49 **Alloy wheels**

Standard wheels

Optional wheels

AMG wheels

51 **Retailer-fit accessories**

52 **Services**

Test drive

Mercedes-Benz Finance and Insurance

Factory Collection

Interactive Owner's Manual

Roadside Assistance

Mercedes-Benz World

54 **Dimensions**

55 **Technical data**

57 **Paint finishes**



## BlueEFFICIENCY – technology for more efficient driving

Our comprehensive BlueEFFICIENCY measures have already brought significant cuts in fuel consumption to many current Mercedes-Benz models, helping to lower both their CO<sub>2</sub> emissions and their running costs. What's more, we are continuing to develop new environmentally friendly technologies that will reduce emissions even further and help to make motoring more sustainable in the long term.

### **BlueEFFICIENCY – the Mercedes-Benz efficiency drive.**

BlueEFFICIENCY models feature a range of measures that can considerably reduce fuel consumption and CO<sub>2</sub> emissions. They include aerodynamic optimisation, low-resistance tyres and intelligent energy management technologies such as the ECO start/stop function, which comes as standard on the majority of our passenger car models. Many of our model ranges also now offer new BlueDIRECT engines. Their innovative direct petrol injection system delivers significantly more power, yet also helps to cut fuel consumption by up to 25%.

**BlueTEC – cleaner diesel power.** BlueTEC is our cleanest diesel technology to date. Its combination of advanced common-rail direct injection, optimised combustion and modular emissions control systems reduces particulate levels by up to 95% and removes up to 90% of nitrogen oxides, leaving little but water and nitrogen.

### **HYBRID – internal combustion at its most intelligent.**

Our hybrid system combines a conventional petrol engine with an electric motor that boosts acceleration and enables brake energy to be recuperated and stored in the battery. In addition, our latest-generation hybrid models offer all-electric propulsion at up to approx. 20 mph, as well as the ability to 'glide' at speeds of up to 100 mph, by shutting down the combustion engine for maximum efficiency and zero emissions. In the E-Class, this advanced hybrid technology can also be enjoyed in diesel form, thanks to the new E 300 BlueTEC HYBRID.<sup>1</sup>

**E-Cell and F-Cell – new drivetrain concepts.** We've also already rolled out limited production runs of two all-electric vehicles with zero local emissions: the A-Class E-Cell<sup>2</sup> and the B-Class F-Cell.<sup>2</sup> The F-Cell uses a hydrogen fuel cell to drive its electric motor, while the E-Cell is powered solely by twin lithium-ion batteries. Our F 125! F-CELL Plug-In HYBRID, meanwhile, demonstrates the possibilities of innovative zero-emission motoring for luxury vehicles.

**Design for Environment.** Our environmental philosophy is not just about in-car technologies. It also involves taking the entire lifecycle of each vehicle into account, from its initial planning to its end-of-life recycling. In addition, Mercedes-Benz is involved in the development of alternative fuels and conducts research in the field of bionics.

For more information about our holistic approach, see [www.mercedes-benz.com/blueefficiency](http://www.mercedes-benz.com/blueefficiency)

<sup>1</sup> E 300 BlueTEC HYBRID Saloon: Euro 5 emissions rating. Fuel consumption, urban: 4.3–4.2 l/100 km; extra-urban: 4.3–4.2 l/100 km; combined: 4.3–4.2 l/100 km; combined CO<sub>2</sub> emissions: 112–109 g/km; efficiency rating A+ <sup>2</sup>Provisional efficiency rating A+

Figures obtained in accordance with the prescribed measuring process (Regulation 715/2007/EC in the currently applicable version). The figures are not based on an individual vehicle and do not constitute part of the product offer; they are provided solely for purposes of comparison between different vehicle models

## Efficiency in the C-Class Coupé

With our BlueEFFICIENCY measures, we are helping to reduce fuel consumption and CO<sub>2</sub> emissions across the Mercedes-Benz passenger car range. They come as standard on all C-Class Coupé models.



The BlueEFFICIENCY measures for the C-Class Coupé include intelligent power-managed units and optimised aerodynamics. In addition, fuel consumption is further reduced by our ECO start/stop function,<sup>1</sup> which almost imperceptibly cuts the engine when queuing or coming to a standstill.

- 1 Radiator shutter
- 2 Enhanced aerodynamics
- 3 Weight savings
- 4 Optimised engines
- 5 Intelligent energy management
- 6 ECO start/stop function
- 7 Driver information that encourages fuel-efficient driving style
- 8 Tyres designed for lower rolling resistance
- 9 Energy-saving fuel pump (diesel models) and power steering pump
- 10 Air-conditioning compressor only active on demand

<sup>1</sup> Not available on C 63 AMG



## Diesel engines

The diesel engines for the C-Class Coupé are efficient, refined and powerful, offering significantly higher outputs and lower fuel consumption than conventional diesel units.

**4-cylinder diesel engines.** Impressive performance is achieved courtesy of a range of technical innovations, resulting in figures of 170 hp (125 kW) for the C 220 CDI BlueEFFICIENCY and 204 hp (150 kW) for the C 250 CDI BlueEFFICIENCY. The high-pressure injection system injects fuel at up to 2,000 bar and sends only the required amount of fuel into the combustion chambers. The chambers themselves have been optimised to ensure fuel burns as cleanly and efficiently as possible, while the

intelligent alternator management system means the alternator is only active when needed, reducing the load on the engine. There are also efficient twin turbochargers and twin balancer shafts that keep the engine running smoothly at all times.

Both 4-cylinder diesel models come with the ECO start/stop function and meet the Euro 5 standard for exhaust emissions.

**Additional efficiency measures.** All our engines come with ECO start/stop,<sup>1</sup> almost imperceptibly cutting the engine when the car is stationary or coming to a complete standstill. The ECO display that is available on many models evaluates the efficiency of the driver's driving style, allowing the driver to actively reduce consumption.

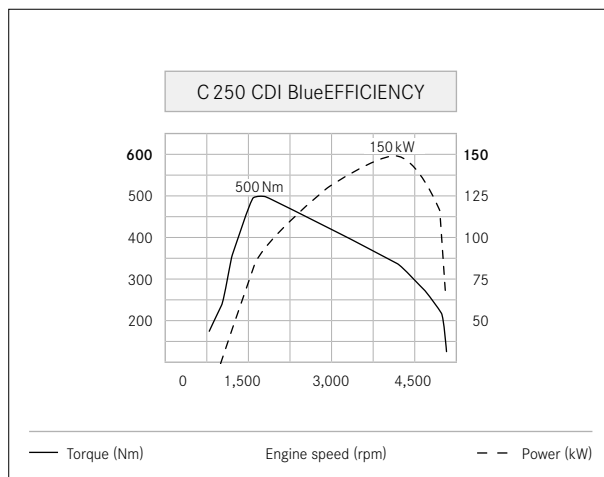

With high levels of torque even at low engine speeds, the C 250 CDI BlueEFFICIENCY delivers instant acceleration

<sup>1</sup> Not available on C 63 AMG



The 4-cylinder engine for the C 220 CDI BlueEFFICIENCY features advanced Mercedes-Benz diesel technology



## Petrol engines

Enjoyment and efficiency can go hand in hand – as the C-Class Coupé's petrol engines prove. Both the 4-cylinder models and V6 variant deliver exceptionally refined performance and impressively low fuel consumption.

**4-cylinder petrol engines.** Our latest-generation petrol engines offer both increased power and reduced fuel consumption. It's a feat they achieve thanks to advanced engine technology and BlueEFFICIENCY. Direct injection at up to 200 bar gives an optimum air/fuel mixture and increased engine efficiency. The latest-generation engine management also optimises the valve timing by adjustment of the camshafts and uses multi-hole piezo injectors. A particular benefit is the saving in engine

weight by using a cast hollow crankshaft and aluminium for the cylinder block. Further optimisation brings additional savings in consumption – the electronic steering in the C180 BlueEFFICIENCY, for example. It only draws energy when the steering wheel is moved – without any loss in comfort.

The C180 BlueEFFICIENCY accelerates from 0 to 62 mph in 8.5 seconds and goes on to reach a top speed of 140 mph, while the C 250 BlueEFFICIENCY dispatches the same sprint in just 7.2 seconds and continues all the way up to a maximum 149 mph.

**V6 petrol engine.** Powerful, economical and clean, the C 350 BlueEFFICIENCY perfectly embodies the virtues of our new-generation petrol engines. Despite delivering 306 hp (225 kW) and accelerating from 0 to 62 mph in just 6.0 seconds, it achieves a remarkably frugal 40.4 mpg on the combined cycle. What's more, its peak torque of 370 Nm is available across a broad rev range, ensuring instant responses whatever the situation or speed. The key to this impressive blend of efficiency and performance is our latest-generation direct petrol

injection system. It features spray-guided combustion and highly precise piezo injectors and works in conjunction with continuously variable camshaft control, which ensures precisely the right amount of fuel is used for any given situation.

**Additional efficiency measures.** All our engines come with ECO start/stop,<sup>1</sup> almost imperceptibly cutting the engine when the car is stationary or coming to a complete standstill. The ECO display that is available on many models evaluates the efficiency of the driver's driving style, allowing the driver to actively reduce consumption.

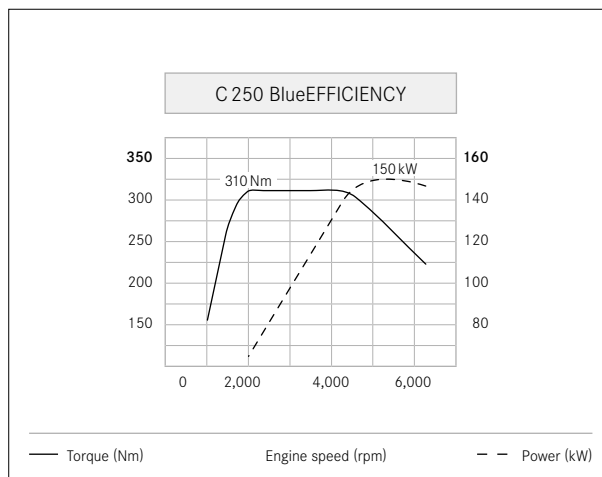

The power and torque curves are impressive, the fuel consumption figures even more so

<sup>1</sup> Not available on C 63 AMG



The C 350 BlueEFFICIENCY combines excellent performance with efficient use of fuel

# Transmissions

The transmissions for the C-Class Coupé ensure optimum performance whatever the situation or engine speed.

**6-speed manual transmission.** The 6-speed manual transmission combines impressive efficiency with a sporty feel. The ratios are ideally matched to the engine and the short, precise shift throws ensure every gear change is a pleasure. Manual C-Class Coupé models are equipped with a shift point indicator and current fuel consumption display that help you to optimise efficiency and reduce CO<sub>2</sub> emissions. The standard ECO start/stop function, meanwhile, helps to achieve further fuel-savings, cutting the engine automatically when stationary or coming to a standstill, and restarting it as soon as you touch the accelerator or depress the clutch.

**7G-Tronic Plus.** 7G-Tronic Plus is the latest version of our 7-speed automatic transmission. It helps to improve fuel consumption by ensuring the engine is always operating at the optimum speed, yet delivers faster, smoother shifts and better acceleration too, even skipping gears in kick-down for more rapid overtaking. In addition, 7G-Tronic Plus allows you to switch between comfort and sport modes as the mood takes you. 7G-Tronic Plus comes as standard on the C 250 BlueEFFICIENCY and C 350 BlueEFFICIENCY and is available as an option on all other models.

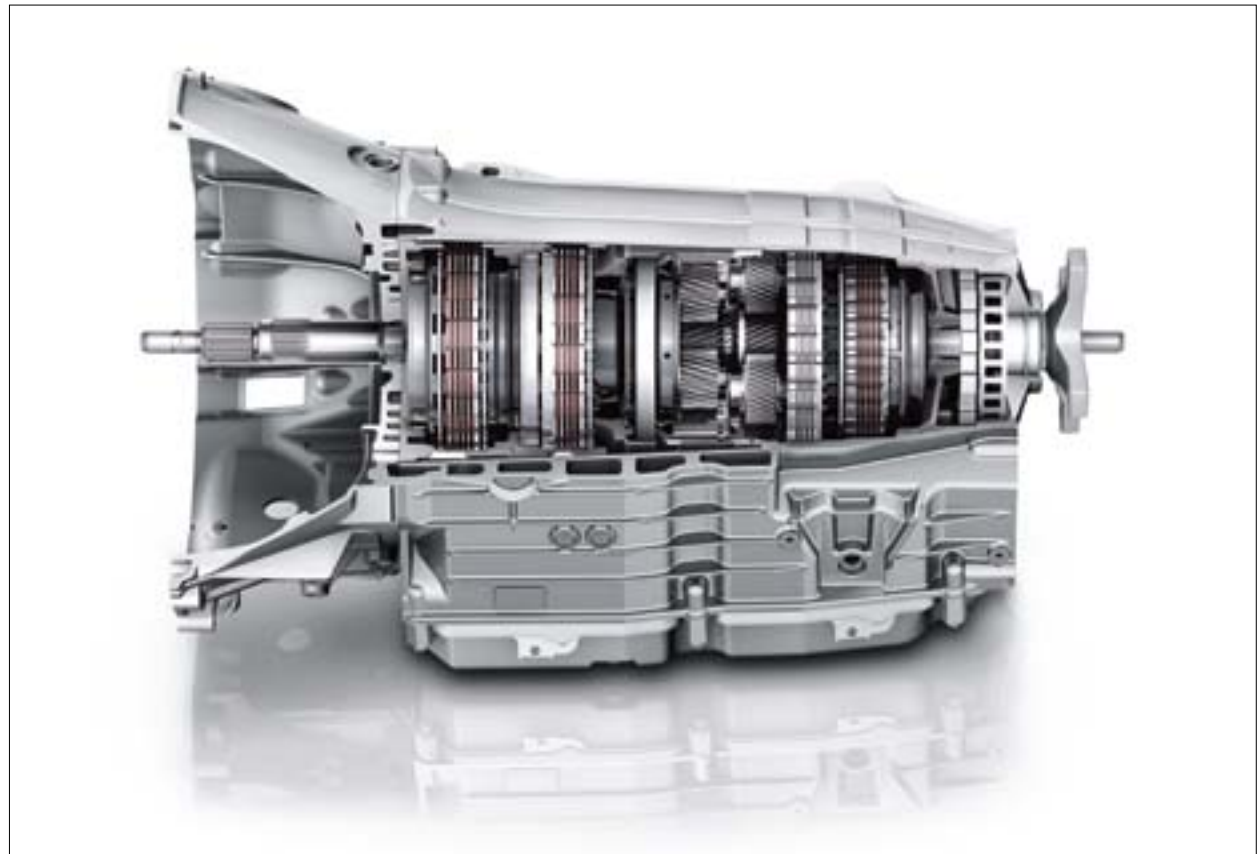

7G-Tronic Plus: the result of more than 50 years' experience in automatic transmission technology



## AMG Handling Package

**Style guide for the perfect bend: match the new AMG Handling Package with the AMG Sport Plus model.**

The AMG Handling Package offers technical and styling enhancements, carefully 'engineered by AMG' for the true sports enthusiast (optional on AMG Sport Plus; only available on C 250 BlueEFFICIENCY and C 250 CDI BlueEFFICIENCY). The larger brakes, sports exhaust and sports tuning of the engine and transmission lend even greater driving dynamics to the AMG Sport Plus. These additions are complemented with subtle exterior styling cues including black exterior mirrors, sport badging on the front wings and floor mats; and a black lamella grille with chrome highlights.



## Integrated safety concept

The C-Class Coupé comes with a host of safety features that help to avoid danger and make for a more relaxing journey.

As the inventor of the motor car, we feel a particular responsibility towards road safety. That's why we were the first manufacturer to develop an integrated safety concept that seamlessly combines a car's active and passive safety features, thus ensuring optimum all-round protection. This concept covers four different areas – safer driving, anticipating danger, protecting occupants and post-crash safety – and incorporates measures designed to maximise safety in every situation, by helping you to stay safe, alerting you to danger, and assisting you wherever possible. In addition, our unique Pre-Safe® anticipatory safety system recognises likely accident scenarios and takes steps that help to further enhance occupant protection. If a collision can't be avoided, intelligent passive safety systems help to provide protection where it's needed, while solutions that can minimise the consequences of an accident and facilitate emergency assistance are also a key part of this safety concept.

A selection of these technologies for the phases 'safer driving', 'anticipating danger', 'protecting occupants' and 'post-crash safety' are presented on the following pages.

**Safer driving: Attention Assist** (standard). If it detects signs of tiredness, Attention Assist alerts the driver via visual and acoustic warnings and recommends taking a break. It monitors driver behaviour via an array of sensors and registers unexpected changes that may indicate drowsiness or concentration lapses.



Attention Assist can detect the onset of tiredness and alert you to the need for a break

**Safer driving: Intelligent Light System with Adaptive High Beam Assist and LED daytime running lights** (standard). The Intelligent Light System comprises a variety of modes and functions: country mode, motorway mode, fog mode, cornering light function and the Active Light System for better visibility in bends. It also includes LED daytime running lights and Adaptive High Beam Assist, which maximises the headlamps' range when no other road users are within sight, then automatically dips the beams if the lights of an oncoming vehicle are detected.

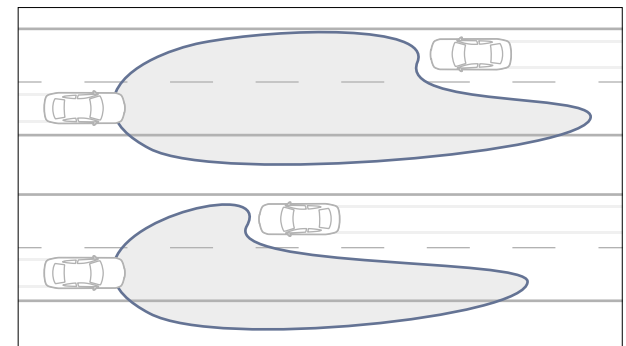

The Intelligent Light System automatically optimises visibility in a range of different situations

**Safer driving: LED tail lights and adaptive brake lights** (standard). During emergency braking, the adaptive brake lights flash 5.5 times per second, sending a clear warning to those behind. If the car is brought to a standstill from a speed of more than 44 mph, the hazard warning lights are also switched on automatically.



The LED tail lights and adaptive brake lights increase your visibility and safety

**Safer driving: Driving Assistance Package** (optional). This package comprises a range of intelligent safety technologies. Active Lane-Keeping Assist draws the driver's attention to unintended lane changes, gently vibrating the steering wheel if the car wanders across lane markings. If the driver doesn't react to the warning, the system is able to intervene in order to correct the car's course. Active Blind Spot Assist makes intentional lane changes safer too, using twin radar sensors to watch over the areas not visible in your exterior mirrors. If the sensors spot a vehicle in one of these blind spots, a flashing red

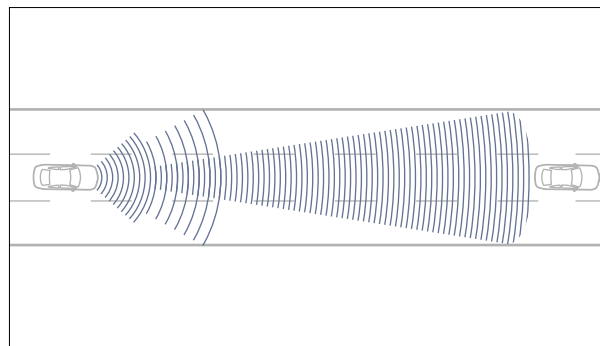

DISTRONIC PLUS can bring the car to a standstill and get you moving again automatically – a boon in stop/start driving

triangle appears in the corresponding mirror, accompanied by an acoustic warning from the instrument panel. Should the driver nevertheless proceed to change lanes, the system can intervene and help prevent a collision by automatically applying the brakes on the appropriate side. DISTRONIC PLUS radar-assisted cruise control, meanwhile, enables the car to automatically maintain a preset distance from the vehicle in front, both in high-speed driving and in stop/start traffic. Also included in the package are our Brake Assist (BAS Plus) and Pre-Safe® Brake system – to give that feeling of safety on every trip.



**Anticipating danger: Pre-Safe® Brake and BAS Plus**

(part of optional Driving Assistance Package). If it detects the risk of a collision, Pre-Safe® Brake alerts the driver via visual and audible warnings. At the same time, BAS Plus assesses the brake force required in order to avoid an impact. If the driver applies the brakes but uses insufficient force, BAS Plus automatically raises the braking pressure to a level that exploits the remaining stopping distance to the full, thereby also lessening the likelihood of a shunt from behind.

Should the driver fail to react to Pre-Safe® Brake's warning signals, it slows the car automatically, providing a further warning, and triggers a range of Pre-Safe® measures. If the driver still doesn't respond, the system then initiates autonomous emergency braking, enabling the speed and severity of any impact to be significantly reduced.

**Anticipating danger: Pre-Safe® system** (standard). If it detects a probable accident scenario, Pre-Safe® can take a range of anticipatory measures to reduce the risk of injury to the occupants. These include activating the front seat belt tensioners, automatically closing the windows and, if the optional Memory Package is fitted, moving the front passenger seat to a more favourable position.

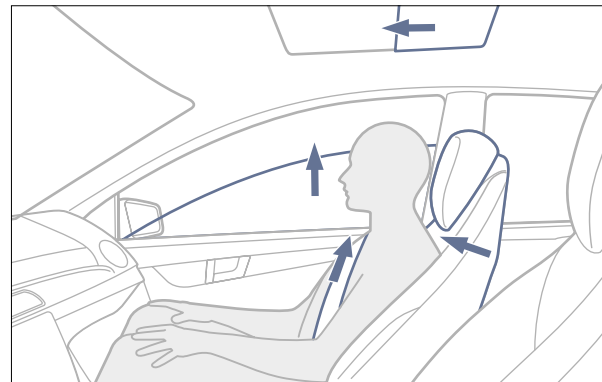

The Pre-Safe® system can detect critical situations and take anticipatory measures to enhance occupant protection

**Anticipating danger: Neck-Pro active head restraints**

(standard). The Neck-Pro front head restraints help to reduce the risk of whiplash injuries. Within milliseconds of a rear-end impact, they automatically move forwards and upwards, enabling them to support the head sooner.

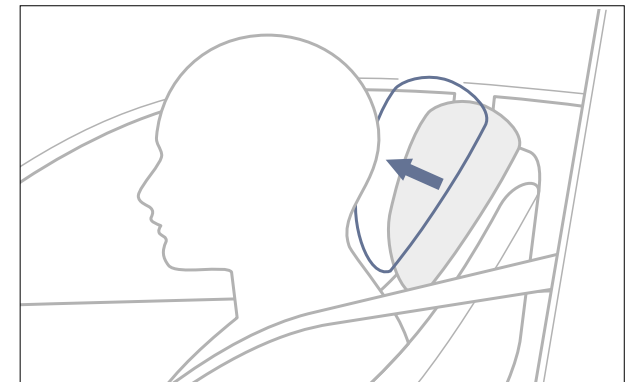

The Neck-Pro active head restraints can help to avoid whiplash injuries in rear-end collisions



**Protecting occupants: restraint systems** (standard).

The 3-point seat belts, seat belt tensioners, belt force limiters and airbags are all carefully coordinated so as to keep injuries to a minimum. The C-Class Coupé is fitted with numerous airbags to ensure optimum occupant protection, with front, side, pelvisbags for the driver and front passenger, a kneebag for the driver and windowbags as standard. Sidebags are optional for the rear. If the crash sensors detect an impact, the seat belts are instantly tensed, helping to ensure the occupants remain firmly in

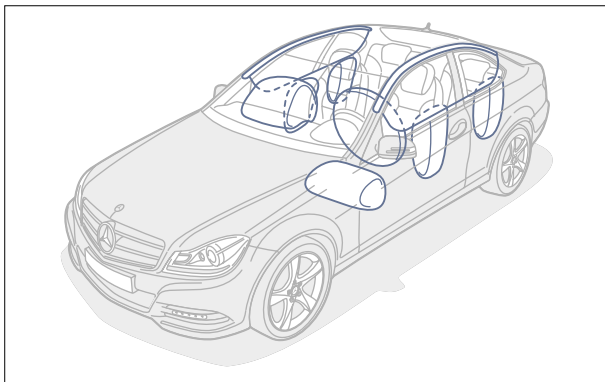

The rigid passenger cell, front and rear crumple zones and intelligent restraint systems provide optimum protection in the event of an impact

their seats, while the belt force limiter relaxes the belt as the situation allows, in order to prevent undue force being applied to the rib cage.

**Protecting occupants: Active Bonnet** (standard).

The Active Bonnet helps reduce the risk of injury to more vulnerable road users, such as pedestrians and cyclists. On impact, the bonnet springs up by 5 cm to better absorb the collision.

**Post-crash safety: Mercedes-Benz Emergency Call System** (part of COMAND Online systems).

The system can automatically send an emergency call via an operational telephone connected to the vehicle, as soon as the restraint system detects a collision. The GPS coordinates are sent to the Mercedes-Benz emergency call centre and a speech connection is then set up. The emergency call can also be triggered manually.

**Post-crash safety.** Mercedes-Benz has developed a range of measures that help to minimise the secondary consequences of an accident and facilitate occupant rescue. These include automatic engine cut-off, self-activating hazard lights and emergency cabin lighting. In addition, the central locking system is automatically released in the event of an accident, and there are special crash joints between the front doors and wings that make it easier to open the doors after frontal collisions. In addition, Mercedes-Benz provides a rescue guide for emergency services that can be downloaded from the Internet at [www.mercedes-benz.co.uk/rescueguide](http://www.mercedes-benz.co.uk/rescueguide)



## Multimedia systems

With its high-quality multimedia and navigation systems, the C-Class Coupé helps you to reach your destination as swiftly as possible – and keeps you entertained all the way.



The large TFT display presents maps, videos or online content in high resolution

**COMAND Online** (optional). The COMAND Online system combines hard disk drive navigation with in-car Internet access and a wide range of entertainment features. These include speed-sensitive volume adjustment, a music library with 10 GB of storage space for audio files and a DVD drive that plays CDs, MP3s, and video or audio DVDs. It also enables you to connect a variety of external devices and storage media – via USB port, Media Interface, SD memory card slot or Bluetooth® interface – and lets you access not only Mercedes-Benz services online, but connects to the Internet for weather updates, Google Street View or Facebook, or helps to find parking facilities while on the move (Internet-enabled mobile phone required). Maps and menus are presented on a high-resolution 7-inch colour display, and all key functions can be operated either via the central controller, from the multi-function steering wheel or using Linguatronic voice control. Three years of map updates are offered free of charge.





**Harman Kardon® Logic 7® surround sound system** (optional). With its 12 high-performance speakers and Logic 7® multi-channel spatial sound technology, this 450-watt surround sound system makes every journey a listening experience to remember. In addition, it comes with speed-sensitive volume adjustment that levels the audio output as you drive.



The Harman Kardon® Logic 7® surround sound system offers a truly first-class listening experience

**Audio 20** (standard). The Audio 20 system features a radio, a 6-disc CD changer with MP3 playback, aux-in and USB ports, and a Bluetooth® interface for hands-free mobile telephony. It also comes with a 5.8-inch TFT display and can be operated remotely via the multi-function steering wheel. A DAB digital radio tuner is included as standard on the C-Class Coupé.



The Audio 20 system features 8 carefully combined speakers that deliver excellent sound

**Becker® Map Pilot navigation system** (optional). With the Becker® Map Pilot navigation system, you'll always reach your destination as safely and quickly as possible. Installed in the glove compartment, the Map Pilot can be integrated with Audio 20 CD system's central controller and display and tailored to your needs by downloading additional functions and map data.



## Electronic assistants

The C-Class Coupé is available with electronic assistants that enhance safety and convenience in a range of situations. They can help you to avoid danger during lane changes, lend a hand in low-speed manoeuvres – and even keep an eye on the speed limit for you.



Speed Limit Assist even recognises and displays temporary speed restrictions

**Speed Limit Assist** (fitted with the optional COMAND Online system). Speed Limit Assist reads speed limit signs and displays the permitted maximum speed in the instrument panel and on the COMAND Online navigation screen until the limit changes. Its front-mounted camera detects round speed limit warnings, both on roadside signs and on overhead gantries, and is particularly useful in areas where the speed limit varies or when passing through roadworks. To help identify the limit correctly, it compares speed limit signs with map data from the navigation system, enabling it to recognise when you are entering or leaving built-up areas for instance.



**Reversing camera** (optional; only in conjunction with COMAND Online system). This rear-mounted camera makes for safer and easier parking manoeuvres. Activated automatically as soon as the driver engages reverse, it captures the area immediately behind the car and enables you to see the image on the COMAND Online display.



The reversing camera makes for easier manoeuvring in tight spaces

**Parktronic with Advanced Parking Guidance** (standard). Parktronic uses the sonar principle to help you avoid low-speed knocks during parking manoeuvres. It sends out ultrasound signals that reflect off other objects and are picked up by sensors in the front and rear bumpers. The system then processes this information and calculates the size of the gap to the front and rear, enabling it to alert you via acoustic and visual warnings as you approach the vehicle or object.



At speeds of up to 22 mph, Advanced Parking Guidance can automatically measure the length of parallel parking spaces

**Lane-Tracking Package** (optional). This option package combines two assistants that enhance safety in multi-lane driving. Lane-Keeping Assist detects white road markings and warns you via subtle vibrations of the steering wheel should you unintentionally stray out of lane. At speeds of approximately 20 mph or above, Blind Spot Assist uses twin radar sensors to monitor the hard-to-see areas either side of the rear, enabling it to recognise and warn you of potentially dangerous lane changes.



Fitted as part of the optional Lane-Tracking Package, Blind Spot Assist warns of potentially dangerous lane changes



## Seats

The C-Class Coupé features coupé-specific front seats, individual rear seats and integral head restraints all round. Its eye-catching seats not only look the part, they also offer excellent ergonomics and high levels of support even in sporty driving.



Coupé-specific front seats lend the C-Class Coupé cabin a sporty look and feel

**Coupé-specific front seats.** For the driver and front seat passenger, the C-Class Coupé offers ergonomically designed coupé-specific seats. They come upholstered in a combination of cloth and Artico artificial leather, with genuine leather available as an option, and have electric seat height and backrest angle adjustment as standard. Heated or comfort-ventilated seats are also available as an option.

**Individual rear seats with integral head restraints.** Those in the rear benefit from ergonomic, individually sculpted seats with integral head restraints. They echo the sporty style of the coupé-specific front seats and come with an asymmetric split/fold mechanism. Also fitted as standard is the Easy-Entry system, which provides more convenient access to the rear seat accommodation.





The standard Easy-Entry system facilitates access to the rear, sliding the front seats all the way forward when released

**Memory Package** (optional). The optional Memory Package ensures you can always find your preferred driving position quickly and easily, even if your C-Class Coupé is regularly driven by someone else. It allows up to three different driver's seat, steering column and exterior mirror positions to be stored and recalled at any time.



With the optional Memory Package, your preferred driving position can be restored at the touch of a button





Image shows optional 19" AMG multi-spoke alloy wheels in matt Black



## C 63 AMG Coupé

For the first time ever, the fastest C-Class is also available in coupé form. The C 63 AMG Coupé combines the race-honed technology of its four-door cousins with a dramatic and highly individual style. Its sporty coupé lines are made even more eye-catching by the AMG grille with single chrome louvre, an AMG-specific bonnet with powerdomes, and AMG bodystyling comprising front and rear aprons plus side skirts. The AMG sports exhaust system's two sets of twin chromed tailpipes provide a further clue to the power of this exhilarating coupé, while AMG-specific daytime running lights and 18" 5-twin-spoke AMG alloy wheels in burnished Titanium Grey finish also come as standard (19" AMG multi-spoke wheels in Titanium Grey or Black are available as an option).

---

### Exterior

---

18" AMG 5-twin-spoke alloy wheels with burnished Titanium Grey finish

---

AMG bodystyling, comprising front apron with side air vents and gloss black cross-bar, side skirts and diffuser-style rear apron

---

AMG spoiler lip on boot lid

---

AMG high-performance braking system with 360 × 36 mm front brake discs and 330 × 26 mm rear discs

---

LED tail lights

---

Panoramic sunroof

---

Wider front wings with '6.3 AMG' badges

---





Stylish, sporty and highly exclusive, the interior of the C 63 AMG Coupé feels instantly special. Its supportive AMG sports seats are upholstered in black single- or two-tone *designo* leather. The flat-rimmed AMG Performance steering wheel features tactile nappa leather trim and aluminium gear shift paddles, and there's an ergonomic AMG-specific instrument panel with colour display and AMG start-up screen. Eye-catching AMG door sill strips and brushed stainless steel sports pedals also come as standard (carbon-fibre trim is available as an option).

→ [www.mercedes-amg.com](http://www.mercedes-amg.com)



Image shows optional carbon-fibre trim

#### Interior

Aluminium trim

AMG door sill strips in brushed stainless steel

AMG instrument panel with high-resolution 4.5-inch color display, including Racetimer and AMG start-up screen

AMG sports parameter steering

AMG sports seats with *designo* Black leather upholstery

Attention Assist

Brushed stainless steel sports pedals with rubber studs

COMAND Online system with Media Interface

DAB digital radio tuner

Flat-rimmed AMG Performance steering wheel with nappa leather trim and aluminium gear shift paddles

Rotary switch for transmission modes and Race Start function

## C 63 AMG technology

The AMG 6.3-litre V8 delivers exceptional power, the sports transmission and suspension help you exploit it to the full – and let you switch between performance- and comfort-biased set-ups. → [www.mercedes-amg.com](http://www.mercedes-amg.com)

**AMG 6.3-litre V8.** Under the bonnet of the C 63 AMG is a naturally aspirated V8 equipped with track-honed racing technologies. These include variable camshaft timing, four valves per cylinder, an exceptionally rigid aluminium crankcase and a special low-friction coating for the cylinder contact surfaces. For optimum cylinder charging, this high-tech engine also features vertically arranged intake and exhaust ports plus a magnesium variable intake manifold with twin throttle flaps. The result is free-revving performance, exceptional pulling power and instant acceleration at all speeds. The C 63 AMG delivers 457 hp (336 kW) at 6,800 rpm, plus 600 Nm of torque at 5,000 rpm, with in excess of 500 Nm available all the way from 2,000 to 6,250 rpm. The AMG Performance Package creates an even more powerful C 63 AMG: it increases output to 487 hp (358 kW), enabling it to accelerate from 0 to 62 mph in a breathtaking 4.4 seconds (4.5 seconds without AMG Performance Package).

**AMG sports suspension.** The AMG sports suspension offers outstanding agility and exceptional lateral acceleration potential. Together with the low-profile tyres, wide front track, AMG sports parameter steering and three-stage ESP,<sup>®</sup> it ensures exceptional vehicle dynamics and an exhilarating driving experience. The triple-link front suspension, firm springing and gas pressure dampers guarantee optimum roadholding and excellent body control even at the limit, yet the ride remains as comfortable as you'd expect from a Mercedes, even on longer journeys. The AMG sports parameter steering features a more direct ratio that gives greater steering precision and allows for even higher cornering speeds, while the Electronic Stability Programme (ESP<sup>®</sup>) is also tailored to the C 63 AMG's high-performance needs. It lets you determine the level of ESP<sup>®</sup> support yourself, allowing you to switch between 'on', 'off' and 'sports handling' modes, and displaying the current setting in the instrument panel.

For exceptional stopping power, an AMG high-performance braking system featuring large, internally ventilated and cross-drilled discs is fitted as standard. It ensures short braking distances and enables the level of brake force to be precisely controlled. The AMG sports parameter steering, meanwhile, is now more direct than ever and offers extra accuracy at high speeds.

As an option, the C 63 AMG Coupé can be fitted with AMG Performance suspension. Its tauter spring and damper settings make for even faster handling responses and a thoroughly focused feel.





**AMG Speedshift MCT 7-speed sports transmission.**

Equipped with AMG aluminium steering wheel shift paddles, four driving modes and a Race Start function, the C 63 AMG's 7-speed sports transmission maximises performance yet delivers high levels of efficiency. The 'S' (Sport), 'S+' (Sport Plus), 'C' (Comfort) and 'M' (Manual) modes each offer different shift characteristics and speeds: gear changes in Sport and Sport Plus modes are around 20% and 40% faster respectively than in Comfort mode, while Manual mode is approximately 50% faster, with shift times of just 100 milliseconds. The transmission also offers automatic throttle-blipping on downshifts. This not only produces a satisfyingly sporty sound, it also helps to reduce load transfer, especially when braking into bends.



The AMG Speedshift MCT 7-speed sports transmission offers a choice of modes that let you enhance comfort or maximise driving pleasure

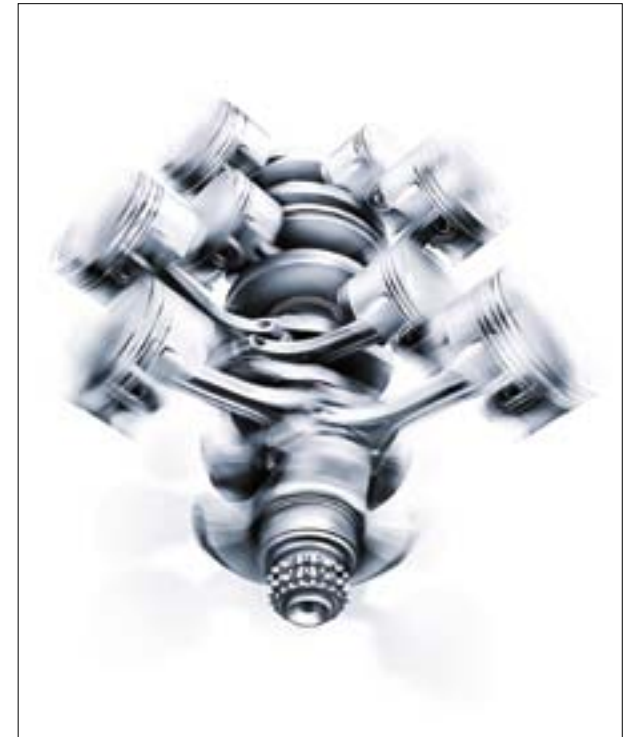

Track-honed technology helps the AMG 6.3-litre V8 to deliver exhilarating performance







## AMG Performance Studio

For an even sportier C 63 AMG, simply add options from the AMG Performance Studio. They include the AMG Performance Package Plus, which comprises an upgraded output of 487 hp (358 kW), a Titanium Grey variable intake manifold, forged pistons, newly-developed connecting rods and revised crankshaft, AMG high-performance composite front brake discs, red brake calipers, an AMG carbon-fibre boot lid spoiler, and an AMG Performance steering wheel with nappa leather and Alcantara® trim. Also available is the AMG Driver's Package, which raises the electronically limited top speed and includes participation at an AMG 'Power & Passion' driving event. The AMG Performance Studio can even fulfil specific customer requests – for everything from personalised vehicles to genuine one-offs.



---

### AMG Performance Studio

18" AMG 5-twin-spoke alloy wheels in burnished Titanium Grey finish, or 19" AMG multi-spoke alloy wheels with Titanium Grey or Black finish

---

AMG Driver's Package

---

AMG illuminated door sill panels

---

AMG Exterior Carbon-Fibre Trim Package, comprising carbon-fibre boot lid spoiler and exterior mirror housings

---

AMG carbon-fibre interior trim

---

AMG rear axle limited-slip differential lock

---



## Standard equipment | Selection



Intelligent Light System with Adaptive High Beam Assist



3-spoke 12-button multi-function steering wheel with nappa leather trim, perforated in central grip area



Automatic climate control



Coupé-specific front seats



LED tail lights



Audio 20 radio with integrated CD changer



ECO start/stop function



USB port and aux-in socket



## Optional extras | Selection



Privacy glass – tinted rear side windows and rear windscreen



COMAND Online system with Linguatronic voice control



Media Interface



Panoramic glass sunroof



Lighting Package



Blind Spot Assist



Keyless-Go





Image shows optional panoramic sunroof



## C-Class Coupé AMG Sport

The AMG Sport makes for a striking and involving C-Class Coupé. Its standard sports suspension and sports parameter steering increase your driving enjoyment, while the AMG styling enhancements add extra muscularity to the exterior. They include an AMG front apron, side skirts, a diffusor-style rear apron and 18" AMG 7-spoke alloy wheels.

---

### Exterior

---

18" AMG alloy wheels – 7-spoke design

---

AMG bodystyling comprising front and rear aprons and side skirts

---

Cross-drilled front brake discs plus calipers with 'Mercedes-Benz' lettering

---

Electric power steering (C 180 BlueEFFICIENCY only)

---

Lowered sports suspension

---

Parktronic, front and rear, with Advanced Parking Guidance

---

Sports parameter steering (excluding C 180 BlueEFFICIENCY)

---





Image shows optional leather interior, comfort-ventilated seats, COMAND Online and Harman Kardon® Logic 7® surround sound system

The AMG Sport interior not only looks more dynamic, it feels it too. The flat-bottomed 3-spoke multi-function sports steering wheel is tactile and grippy, the black steering wheel gear shift paddles (automatic models only) offer racing-style gear changes. Other interior highlights include dark brushed aluminium trim, stainless steel sports pedals, a black roof lining and AMG floor mats, and there's also a large 4.5-inch colour display for the instrument panel.



#### Interior

3-spoke 12-button multi-function sports steering wheel with flat-bottomed rim and nappa leather trim, perforated in central grip area

Attention Assist

Black floor mats with AMG insignia

Black roof lining

Black steering wheel gear shift paddles (with automatic transmission)

DAB digital radio tuner and USB port

Dark brushed aluminium trim

Sports pedals in brushed stainless steel with rubber studs





## C-Class Coupé AMG Sport Plus

The sporting hardware for this AMG Sport Plus has been carefully honed by AMG: AMG styling for front and rear aprons, side skirts, an AMG lip spoiler on the boot lid in body colour and exclusive bi-colour AMG alloy wheels in 7-twin-spoke design. Drilled front brake discs, brake calipers with 'Mercedes-Benz' lettering and tail pipes in polished stainless steel round off an already impressive Coupé.



---

### Exterior

---

18" AMG bi-colour alloy wheels – 7-twin-spoke design

---

AMG spoiler lip on boot lid

---

AMG styling, comprising front and rear aprons and side skirts

---

Brake calipers with 'Mercedes-Benz' lettering, drilled front brake discs, tail pipes in polished stainless steel

---

Electric power steering (C 180 BlueEFFICIENCY)

---

Sports suspension, lowered

---

Sports parameter (speed-sensitive) steering excluding C 180 BlueEFFICIENCY







An interior to please the most discerning: red decorative stitching on the AMG sports seats and red *designo* seat belts contrast with silver gear shift paddles on the 3-spoke multi-function sports steering wheel. Dark brushed aluminium decorative trim and black floor mats with AMG logo and red surround complete the interior, as well as the brushed stainless steel pedals.

---

#### Interior

3-spoke multi-function sports steering wheel, flattened at the bottom, with 12 buttons, nappa leather trim with contrasting red stitching and perforated central grip area

AMG floor mats in black with red surround

AMG sports seats with integral head restraints and individual seats in the rear

Centre console armrest, door centre areas and gear lever gaiter with red contrast stitching

Attention Assist

*designo* seat belts in red (black as an option)

Black roof lining

Instrument panel with high-resolution 4.5-inch colour display

Steering wheel gear shift paddles in silver (automatic transmission only)

Upholstery in black Artico artificial leather/*Dinamica*<sup>®</sup> microfibre or black leather (option)

Sports pedals in brushed stainless steel with rubber studs (also on parking brake pedal)

Trims in dark brushed aluminium

---



## Upholstery and trim - AMG Sport



The standard Black interior with Artico artificial leather/ cloth upholstery features Black seats, a black dashboard, black door trims and a black load compartment cover. The A-, B- and C-pillar trims and fabric roof lining are in black. There's additional dark brushed aluminium trim for the dashboard, doors and centre console, with High-Gloss Black or matt-finish Brown Ash wood available as an option.



721



739

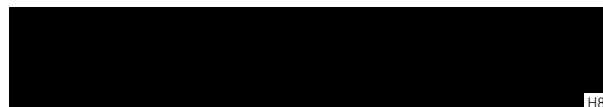

H80



H06

### Black

721 Artico artificial leather/cloth

### Trim

739 Dark brushed aluminium

H80 High-Gloss Black<sup>1</sup>H06 Brown Ash wood, matt finish<sup>1</sup>

Interior image shows optional wood trim

<sup>1</sup> Optional



The standard Alpaca Grey interior with Artico artificial leather/cloth upholstery features Alpaca Grey seats, a two-tone black and Alpaca Grey dashboard, a black load compartment cover and a black fabric roof lining. There's also additional dark brushed aluminium trim for the dashboard, doors and centre console, with High-Gloss Black trim or matt-finish Brown Ash wood available as an option.

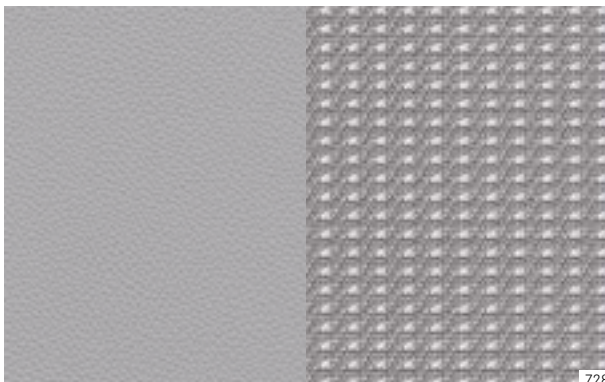

Interior image shows optional wood trim

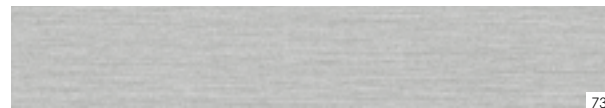

---

#### Alpaca Grey

728 Artico artificial leather/cloth

---

#### Trim

739 Dark brushed aluminium

H80 High-Gloss Black<sup>1</sup>

H06 Brown Ash wood, matt finish<sup>1</sup>

---

<sup>1</sup> Optional





The optional Black interior with leather upholstery features Black leather seats with Dark Alpaca Grey top-stitching, black doors and dashboard. The A-, B- and C-pillar trims, fabric roof lining and load compartment cover are all in black. There's additional dark brushed aluminium trim for the dashboard, doors and centre console, with High-Gloss Black trim or matt-finish Brown Ash wood available as an option.

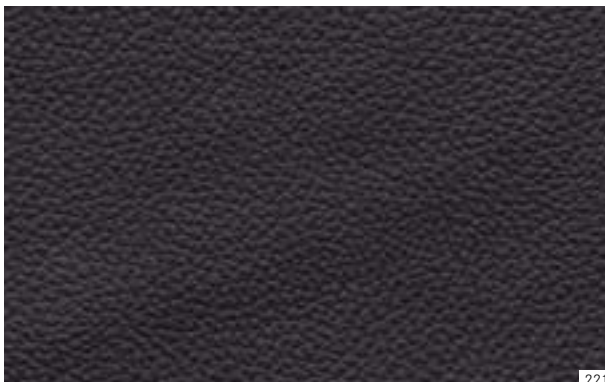

221

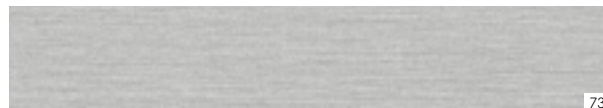

739



H80



H06

---

**Black**

---

221 Leather<sup>1</sup>

---

**Trim**

---

739 Dark brushed aluminium

H80 High-Gloss Black<sup>1</sup>H06 Brown Ash wood, matt finish<sup>1</sup><sup>1</sup>Optional



The optional Alpaca Grey interior with leather upholstery features Alpaca Grey leather seats with Dark Alpaca Grey top-stitching, Alpaca Grey doors and a two-tone Black and Alpaca Grey dashboard. The A-, B- and C-pillar trims, fabric roof lining and load compartment cover are all in black. There's additional dark brushed aluminium trim for the dashboard, doors and centre console, with High-Gloss Black trim or matt-finish Brown Ash wood available as an option.



228

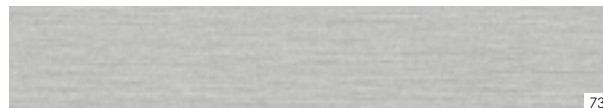

739



H80



H06

---

**Alpaca Grey**

---

228 Leather<sup>1</sup>

---

**Trim**



---

739 Dark brushed aluminium

H80 High-Gloss Black<sup>1</sup>H06 Brown Ash wood, matt finish<sup>1</sup><sup>1</sup> Optional

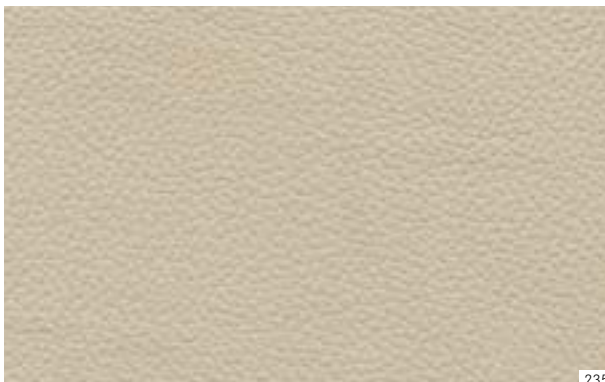

The optional Sahara Beige interior with leather upholstery features Sahara Beige leather seats and top-stitching, with matching Sahara Beige door trim. The dashboard, fabric roof lining and load compartment cover are all in black, as are the A-, B- and C-pillar trims. There's additional dark brushed aluminium trim for the dashboard, doors and centre console, with High-Gloss Black trim or matt-finish Brown Ash wood available as an option.



235

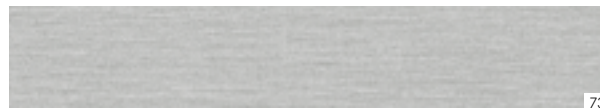

739



H80



H06

---

**Sahara Beige**

---

235 Leather<sup>1</sup>

---

**Trim**

---

739 Dark brushed aluminium

H80 High-Gloss Black<sup>1</sup>H06 Brown Ash wood, matt finish<sup>1</sup><sup>1</sup> Optional



The optional Flamenco Red interior with leather upholstery features Flamenco Red leather seats with black top-stitching and matching Flamenco Red door trim. The dashboard, fabric roof lining and load compartment cover are all in black, as are the A-, B- and C-pillar trims. There's additional dark brushed aluminium trim for the dashboard, doors and centre console, with High-Gloss Black trim or matt-finish Brown Ash wood available as an option.



237



739

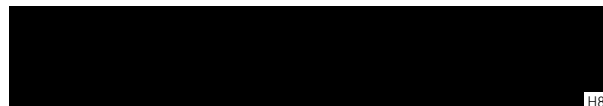

H80



H06

---

**Flamenco Red**

---

237 Leather<sup>1</sup>

---

**Trim**

---

739 Dark brushed aluminium

H80 High-Gloss Black<sup>1</sup>H06 Brown Ash wood, matt finish<sup>1</sup><sup>1</sup>Optional

## Upholstery and trim - AMG Sport Plus



The standard Black interior with Artico artificial leather/ Dinamica® microfibre features a black dashboard, black door trim and a black load compartment cover. Red contrast stitching features on the seats, dashboard, centre console, door centre areas and gear lever gaiter. Black nappa leather seat upholstery is available as an option. The A-, B- and C-pillar trims and fabric roof lining are in black. There's additional dark brushed aluminium trim for dashboard, doors and centre console.



231

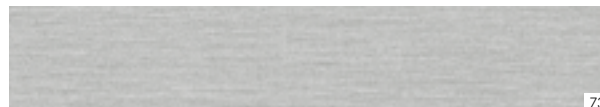

739

---

### Black

741 Artico/Dinamica®<sup>1</sup>231 Leather with red stitching<sup>2</sup>

---

### Trim

739 Dark brushed aluminium

<sup>1</sup> Artico artificial leather/ Dinamica® microfibre with red contrast stitching    <sup>2</sup> Optional





## Alloy wheels



18" AMG 7-spoke alloy wheels (standard on AMG Sport, code 782)



18" AMG 5-twin-spoke alloy wheels (optional on AMG Sport, code 786)



18" AMG 5-twin-spoke alloy wheels, with burnished Titanium Grey finish (standard on C 63 AMG, code 795)



19" AMG multi-spoke alloy wheels, with burnished Titanium Grey finish (optional on C 63 AMG, code 788)



18" AMG bi-colour alloy wheels - 7-twin-spoke design (standard on AMG Sport Plus, code 760)



18" AMG 7-spoke alloy wheels, painted black (optional on AMG Sport and AMG Sport Plus, code 661)



18" AMG 5-twin-spoke alloy wheels, with burnished Titanium Grey finish (optional on C 63 AMG, code 790)



19" AMG multi-spoke alloy wheels, painted black (optional for C 63 AMG)





The Mercedes-Benz InCar Hotspot enables wi-fi Internet access



## Retailer-fit accessories

A Mercedes-Benz is not just a car, it's a travel companion that can be tailored to your needs – with our wide range of Retailer-fit accessories.

→ [www.mercedes-benz.co.uk/accessories](http://www.mercedes-benz.co.uk/accessories)

Our Retailer-fit accessories enable you to create the perfect C-Class Coupé for your lifestyle. If you often need to transport lots of luggage or sports gear, you'll find the ideal solution in our range of roof racks and boxes. The boxes come in two different sizes: the family version holds 450 litres while the sports box swallows 330 litres. Both open and close on either side and can be mounted on our Retailer-fit roof bars for safe and secure transportation.



Roof bars with 'Comfort' ski and snowboard rack

Also available are a luggage set and ski bags designed specifically to fit the roof boxes.

Add a sporty touch to your C-Class Coupé with an eye-catching Mercedes-Benz boot spoiler.

A very practical technical feature that puts your mind at rest is Tracker™. If your C-Class Coupé is ever stolen, VHF



Boot spoiler

(Very High Frequency) technology tracks your car's location – even if it's held in a garage or an underground car park.

For more details about these and other C-Class Coupé accessories, please see the relevant brochure or talk to your local Mercedes-Benz Retailer.



Tracker™



## Services

**Test drive.** Words can only do so much. Some things have to be experienced to be truly appreciated. Which is why we'd like to invite you for a test drive. Feel the power of efficient engines that offer impressive fuel consumption. Feel exhilarated by precise steering, designed to connect the driver with the road and enjoy sumptuous levels of comfort. Your Mercedes-Benz Retailer will be happy to make arrangements for you to experience the things that set a Mercedes-Benz apart. Alternatively, to request a test drive online simply visit [www.mercedes-benz.co.uk/testdrive](http://www.mercedes-benz.co.uk/testdrive). We look forward to seeing you.

**Mercedes-Benz Finance.** At Mercedes-Benz Finance, our single-minded aim is to provide optimum financial solutions for all those who share the Mercedes-Benz philosophy of absolute commitment to quality. Whether you are a private customer or a business user, our finance and leasing packages can be tailored to meet your individual

needs. For further information on Mercedes-Benz Finance, please contact your local Mercedes-Benz Retailer.

**Mercedes-Benz Insurance** offers a fully comprehensive 5 star<sup>1</sup> Motor Insurance policy specifically designed to give you the cover you would expect from Mercedes-Benz. For a quotation, please call 0845 600 2180.<sup>2</sup>

**Factory Collection.** What can possibly heighten the experience of taking possession of your brand new Mercedes-Benz? The highlight might just be to see and experience where it was built in Stuttgart, and to take the long way home by driving it through some of Europe's most beautiful countryside. The Mercedes-Benz



Factory Collection offers just that. Included in the Collection is an airport transfer to your hotel, one night's accommodation for one person with dinner and breakfast, a tour of the Mercedes-Benz factory, five days fully comprehensive insurance, and a return crossing by Eurotunnel (Standard Class). All you will need to pay for is your one-way flight to Germany. For more information, please contact your local Retailer, the Mercedes-Benz Factory Collection team on 0845 273 9705 or visit [www.mercedes-benz.co.uk/factorycollection](http://www.mercedes-benz.co.uk/factorycollection)

**Interactive Owner's Manual.** The website also offers an interactive tour, enabling you to take a closer look at your desired model. This simulation is the ideal way to acquaint yourself with your dream car. You can view key functions in detail, gain an insight into the car's inner workings or look at the benefits of each model. For further details, visit [www.mercedes-benz.co.uk/cclasscoupemmanual](http://www.mercedes-benz.co.uk/cclasscoupemmanual)



**Roadside Assistance.** Rest assured that should you ever need help, Mercedes-Benz Roadside Assistance is there for you. In the unlikely event of a technical breakdown<sup>3</sup> you can rely on the Mercedes-Benz Roadside Assistance Team – anywhere in Europe. Simply phone our Customer Assistance Centre on 00800 1 777 7777,<sup>4</sup> where our specialists will organise assistance for you. Mercedes-Benz will also assist you in the event of a minor mishap preventing you from driving your vehicle<sup>3</sup>. Whether you lose your key, run out of fuel or your vehicle is damaged due to an accident or vandalism, Mercedes-Benz ensures that you still reach your destination. Often the problem can be rectified on the spot, but if this is not possible, we will naturally ensure that your vehicle is taken to the nearest Mercedes-Benz Official Workshop to get you back on the road as quickly as possible.

<sup>1</sup> As rated by Defaqto, a leading UK independent financial research company.  
Mercedes-Benz Motor Insurance is underwritten by Aviva Insurance Limited  
<sup>2</sup> Calls are charged at local rate and may be recorded

**Mercedes-Benz World at Brooklands.** Celebrate the story of Mercedes-Benz and you'll celebrate the story of motoring itself at Mercedes-Benz World in Surrey. A World of experiences. Discover Mercedes-Benz racing heritage, from its connections to the famous Brooklands circuit through to present-day Formula 1™ brought to life in the most sensational way. View, touch and sit in every car from the Mercedes-Benz range, and encounter automotive legends like the 'Gullwing' and many other classic icons, in the UK's largest Mercedes-Benz showcase. Then set your pulse racing by booking one of our thrilling Driving Experiences. Enjoy AMG performance on the purpose-built Handling Circuits or Wet Skid Circle, an axle-twisting off-road adventure, or treat your kids over 1.5 metres tall to their own driving experience in an A-Class or on the off-road terrain in an M-Class.

<sup>3</sup> Cover is initially valid for your vehicle for four years from the date of first registration. This can be extended from the fifth year, up to a maximum of 30 years, on completion of each scheduled maintenance service, providing that this service is carried out by a Mercedes-Benz

And for kids even younger and under 1.3 metres tall, let them be a 'Little Learner' in their own miniature electric version of the desirable Mercedes-Benz SL. For more interactive action, take a virtual 3D journey along the production line in 'Build' and take a seat in the cinema to accelerate from the birth of the car to the latest innovations in 20 eye-opening minutes.

Relax and refuel in Café 1886, or for something more enjoy the delicious menu and elegant surroundings of the Gullwing Restaurant. Finally, extend your visit with a short stroll to Brooklands Museum to see their collection of classic cars, aviation exhibitions – and the legendary Concorde. For more information visit [www.mercedes-benzworld.co.uk](http://www.mercedes-benzworld.co.uk)

Official Workshop. Minor mishap cover is provided at the absolute discretion of Mercedes-Benz  
<sup>4</sup>In non-affiliated European countries: +44 20 7975 7077



# Dimensions

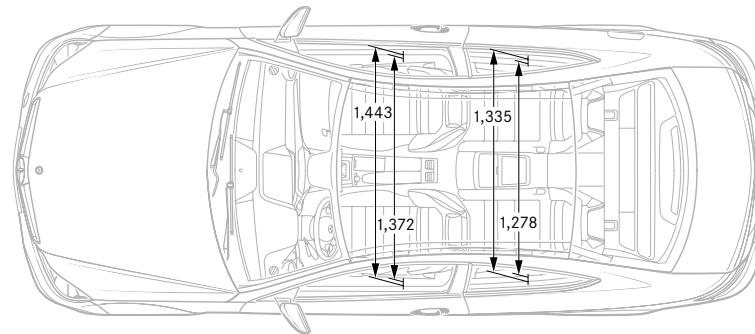
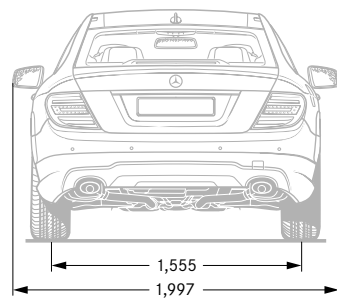
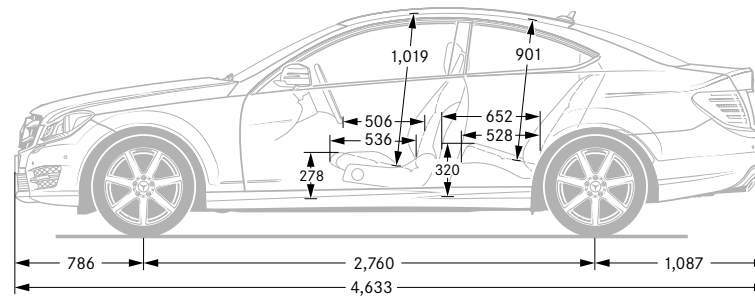
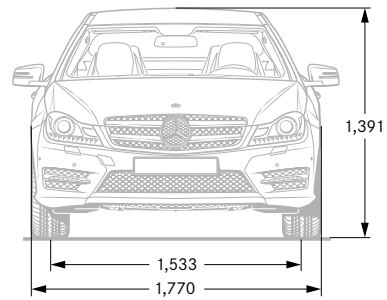

All measurements in millimetres. The dimensions shown are mean values and apply to standard-specification, unladen vehicles



# Technical data

No. of cylinders/arrangement
Total displacement – cc
Rated output <sup>1</sup> – hp (kW) at rpm
Rated torque <sup>1</sup> – Nm at rpm
Acceleration 0–62 mph – sec (auto.)
Top speed approx. – mph (auto.)
Tyre size – front, rear
Fuel consumption <sup>3</sup> – mpg (auto.)
Urban
Extra-urban
Combined
CO <sub>2</sub> emissions, combined <sup>3</sup> – g/km (auto.)
EU emissions standard
Fuel tank capacity/reserve (approx.) – l
Boot capacity – l
Turning circle – m
Kerb weight <sup>4</sup> – kg
Perm. GVW – kg

## Diesel engines

### C 220 CDI BlueEFFICIENCY

4/in-line
2,143
170 (125)/3,000–4,200
400/1,400–2,800
8.4 (8.1)
144 (144)
225/40 R 18, 255/35 R 18
44.8 (43.5)
65.7 (61.4)
55.4 (53.3)
133 (139)
Euro 5
66/8
450
10.84
1,615 (1,630)
2,085 (2,100)

### C 250 CDI BlueEFFICIENCY

4/in-line
2,143
204 (150)/4,200
500/1,600–1,800
7.0 (7.1)
149 (149)
225/40 R 18, 255/35 R 18
41.5 (43.5)
61.4 (61.4)
52.3 (53.3)
143 (139)
Euro 5
66/8
450
10.84
1,655 (1,660)
2,125 (2,130)

<sup>1</sup> Figures according to Directive 80/1269/EEC in the currently applicable version <sup>2</sup> Electronically limited <sup>3</sup> The figures shown were obtained in accordance with the prescribed measuring process (Directive 80/1268/EEC in the currently applicable version). The figures are not based on an individual vehicle and do not constitute part of the product offer; they are provided solely for purposes of comparison between different vehicle models



	<b>Petrol engines</b>			
	<b>C 180 BlueEFFICIENCY</b>	<b>C 250 BlueEFFICIENCY</b>	<b>C 350 BlueEFFICIENCY</b>	<b>C 63 AMG</b>
No. of cylinders/arrangement	4/in-line	4/in-line	6/V	8/V
Total displacement – cc	1,595	1,796	3,498	6,208
Rated output <sup>1</sup> – hp (kW) at rpm	154 (115)/5,000	204 (150)/5,500	306 (225)/6,500	457 (336)/6,800 487 (358)/6,800 <sup>5</sup>
Rated torque <sup>1</sup> – Nm at rpm	250/1,250–4,000	310/2,300–4,300	370/3,500–5,250	600/5,000
Acceleration 0–62 mph – sec (auto.)	8.5 (8.5)	– (7.2)	– (6.0)	– (4.5/4.4 <sup>5</sup> )
Top speed approx. – mph (auto.)	140 (139)	– (149)	– (155) <sup>2</sup>	– (155) <sup>2</sup>
Tyre size – front, rear	225/40 R 18, 255/35 R 18	225/40 R 18, 255/35 R 18	225/40 R 18, 255/35 R 18	235/40 R 18, 255/35 R 18
Fuel consumption <sup>3</sup> – mpg (auto.)				
Urban	34.9 (35.3)	– (31.0)	– (29.4)	– (15.5)
Extra-urban	52.3 (53.3)	– (49.6)	– (50.4)	– (33.6)
Combined	44.1 (44.8)	– (40.4)	– (40.4)	– (23.5)
CO <sub>2</sub> emissions, combined <sup>3</sup> – g/km (auto.)	149 (147)	– (163)	– (164)	– (280)
EU emissions standard	Euro 5	Euro 5	Euro 5	Euro 5
Fuel tank capacity/reserve (approx.) – l	66/8	66/8	66/8	66/14
Boot capacity – l	450	450	450	450
Turning circle – m	10.84	10.84	10.84	11.10
Kerb weight <sup>4</sup> – kg (auto.)	1,490 (1,505)	– (1,550)	– (1,615)	– (1,730)
Perm. GVW – kg (auto.)	1,960 (1,975)	– (2,020)	– (2,085)	– (2,160)

<sup>4</sup>Figures according to Directive 92/21/EC, version 95/48/EC (kerb weight with fuel tank 90% full, driver, 68 kg, and luggage, 7 kg) for standard-specification vehicles. Optional extras and accessories will generally increase this figure and reduce the payload capacity accordingly <sup>5</sup>With optional AMG Performance Package Plus Values in parentheses refer to engines with automatic transmission For more specifications, visit [www.mercedes-benz.co.uk](http://www.mercedes-benz.co.uk)



## Paint finishes

The innovative Mercedes-Benz paint system features one of the finest clearcoats of any manufacturer. Its exceptionally dense molecular structure makes the paintwork more durable and lends it a deeper, more lasting sheen, helping your C-Class Coupé to retain both its looks and its long-term value.

### Non-metallic paints (standard)

- 040 Black
- 149 Polar White
- 590 Fire Opal

### Metallic paints (optional)

- 183 Magnetite Black
- 197 Obsidian Black
- 755 Tenorite Grey
- 775 Iridium Silver
- 792 Palladium Silver
- 890 Cavansite Blue
- 988 Diamond Silver

### Special paints (optional)

- 051 *designo* Magno Platinum<sup>1</sup>
- 799 Diamond White

<sup>1</sup> Only available with AMG Handling Package (code P84)

### Non-metallic paints



040



149



590

### Metallic paints



183



197

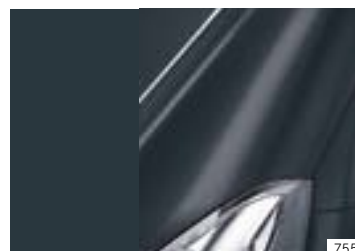

755



775

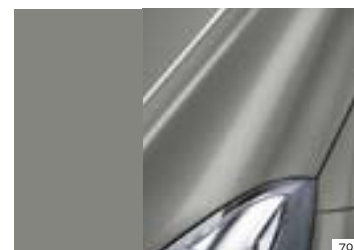

792

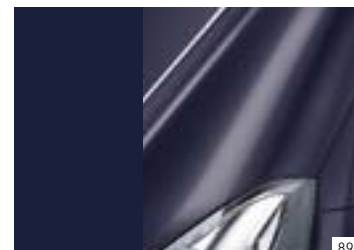

890



988

### Special paints

051<sup>1</sup>

799



**Take-back of end-of-life vehicles. Coming full circle.** At the end of its long life, you can return your C-Class to us for environment-friendly disposal in accordance with the EC End-of-Life Vehicle Directive!<sup>1</sup> But that day lies a long way off.

<sup>1</sup>Applies in accordance with national regulations to vehicles up to 3.5 t permissible gross weight. The C-Class Coupé has met the statutory regulations governing the suitability of the vehicles' design for reuse and recycling for a number of years now. A network of vehicle take-back depots and dismantlers has been established which will process your vehicle in an environment-friendly manner. The ways in which both vehicles and parts can be recovered are subject to ongoing development and improvement. Consequently, the C-Class Coupé will be able to comply with any future increases in the recycling quota within the stipulated time limits. For further information, please go to [www.mercedes-benz.co.uk](http://www.mercedes-benz.co.uk) or call 0808 156 6606.

**Please note:** changes may have been made to the products since this brochure went to press (17.02.2012). The manufacturer reserves the right to make changes to the design, form, colour and specification during the delivery period, provided these changes, while taking into account the interests of the vendor, can be deemed reasonable with respect to the purchaser. Where the vendor or the manufacturer uses symbols or numbers to describe an order or the subject of an order, no rights may be derived solely from these. The illustrations may show accessories and items of optional equipment which are not part of standard specification. Colours may differ slightly from those shown in the brochure, owing to the limitations of the printing process. This brochure has been compiled by Daimler AG of Germany and is distributed internationally. It provides a general indication of the range of models, features, optional extras and/or colours available in various countries. Some of the models, features, optional extras and/or colours shown may not be available in your country or may only be available in a different specification. Additionally some models, features, optional extras and/or colours may only be available in combination with others. For current and more specific information in relation to the range of models, features, optional extras and/or colours available in your country, and their pricing, you should contact your nearest authorised Mercedes-Benz Retailer. E&OE. [www.mercedes-benz.co.uk](http://www.mercedes-benz.co.uk)

