



The Actros. The Axor. The Atego

Construction. 7.5 - 44 tonnes



Mercedes-Benz
Trucks you can trust

Contents

Product portfolio	4 - 5
The Atego	6 - 21
Cab	8 - 11
Economy, technology	12 - 17
Model overview	18 - 19
Cab types	20 - 21
The Axor	22 - 35
Cab	24 - 27
Economy, technology	28 - 33
Model overview	34
Cab types	35
The Actros	36 - 57
Cab	38 - 43
Economy, technology	44 - 49
Model overview	50 - 55
Cab types	56 - 57
Atego, Axor, Actros	58 - 73
Safety	58 - 61
Quality, environment	62 - 67
Servicing, services, accessories	68 - 73

For every construction site. And for the road leading to it.
The Atego, the Axor and the Actros from Mercedes-Benz



With the Atego, the Axor and the Actros, we offer you a range built from the ground up to satisfy the demands of the construction industry. Because, no matter which of the three you choose – each one embodies all the knowledge and experience gained by our engineers over the years, knowledge which they are continually developing further. Designed for robustness, reliability and economy – the essentials for the construction industry.



Three specialists – and the right one for every job

Whether it's the Atego, the Axor or the Actros – when you choose a vehicle from the Mercedes-Benz construction range, you are choosing much more than just robustness, reliability and economy. You are also choosing a vehicle tailored for the job.

From dropsiders to concrete mixers and heavy-duty tippers – the Atego, the Axor and the Actros are true specialists of the construction industry. Thanks to their versatility, they have the answer for virtually every task and for every segment of the construction industry. The Atego and the Axor both enhance working and ride comfort with their many practical details. Never mind whether it's a road, a gravel track or rugged terrain that you have to cross to reach your destination. Every vehicle is equipped with robust, tried-and-tested technology that makes the task easier and smoother. All the powertrain components are produced by Mercedes-Benz, thus ensuring their optimum mutual compatibility. The prime example is the Actros¹⁾, setting standards with equipment such as its 12-speed Mercedes PowerShift offroad automatic transmission, which enables noticeably more dynamism on difficult terrain.

¹⁾ There is detailed information on the standard and special equipment for the Actros from page 36 onwards



A strong trio – the Atego, the Axor and the Actros offer an optimum solution for practically every task imaginable in the construction and building materials industry – with GVWs from 7.5 to 44 t and with high-torque, durable BlueTec® engines from 115 kW (156 hp) to 440 kW (598 hp), which are also characterised by their low fuel consumption and low CO₂ emissions

Different tasks require different tools. That's why there's no "one-size-fits-all" construction vehicle from Mercedes-Benz, but precisely the right one for each requirement instead: the Atego was developed for the specific needs of the building materials industry, and is ideal for light-duty construction site work thanks to its ease of handling and manoeuvrability – perfect



With GVWs ranging from 7.5 to 16 t and its powerful engines, manoeuvrability and compact design, the Atego performs impressively in the building materials industry, with its versatility leaving practically nothing to be desired. More information about the Atego is detailed from page 6 onwards

for work in horticulture, on urban building sites and wherever space restrictions make the going tough. The specific advantage of the Axor is its low kerb weight, which makes it a payload expert, particularly well-suited for delivering supplies such as gravel or other bulk materials to construction sites or for operation as a concrete mixer.



Consistently focused on payload. In the construction and building materials industry, the 18 to 32 t Axor presents countless application options, proving that toughness and a low kerb weight can go together very well. From page 22 onwards you can see what the Axor can do for you

As an all-rounder the Actros certainly shows what it takes to make a true construction-site vehicle and it is eminently suited to fulfil all its tasks in semi-heavy and heavy-duty operation. Whether it's at work in mud and mire or on smooth paved roads, the Actros impresses with its off-road capability, functionality, robustness and economy.



The multi-talent in the 18 to 44 t class. The challenges posed by work in heavy-duty construction-site operation can only be tackled with extreme robustness and power – qualities which the Actros displays abundantly, day in, day out. You, too, will be convinced of the qualities of the construction Actros when you read all the details from page 36 onwards

In a class of its own: the Atego

Low costs, compact dimensions, a small turning circle and practically no wishes unfulfilled – when it comes to functionality and reliability in the building materials industry, the Atego is the very first choice.

Whether you opt for a dropsider, 3-way tipper, an all-wheel-drive tipper or a skip loader – the Atego impresses in many ways: the radiator grille with its diamond-pattern design lends the Atego an unmistakable, striking appearance, and as an option it is available in the vehicle colour. On the inside, the two different cabs have been further optimised with regard to their ride and working comfort.

The frugal 4- and 6-cylinder BlueTec® engines, thanks to which you can comply with Euro 5 cost-effectively, stand for economy and reliability. As an option the Atego¹⁾ is also available as a vehicle that meets the yet more stringent EEV emissions standard²⁾. And the motor start/stop system³⁾ can contribute towards lower consumption and reduced CO₂ emissions. In addition, longer maintenance intervals coupled with a large number of low-maintenance or maintenance-free components increase economy even further. Add to this its excellent handling characteristics and exceptional manoeuvrability and you will see why the Atego is the ideal vehicle for the building materials industry. On city construction sites, in horticulture and landscape gardening and wherever every last centimetre counts. Step inside!

¹⁾ Atego from 130 kW (177 hp) to 210 kW (286 hp)

²⁾ Enhanced Environmentally Friendly Vehicle

³⁾ Standard for the Atego in conjunction with manual gearshift.

Not available with other transmission options







Two cabs. But always “first choice”

With lots of practical equipment and appointments, the Atego once again makes working easier and more efficient. In other words: not only does the workstation in the Atego satisfy discerning requirements when it comes to application orientation and ergonomics; it does so where comfort and safety are concerned, too.

The building materials industry is ruled by laws of its own. And with lots of details and equipment which increase ride and working comfort, the Atego is better placed to abide by them. The Atego is equipped with the S-cab. It impresses with its compact exterior dimensions combined with a large interior allowing plenty of freedom of movement. And the optional S-cab with a 180 mm rear panel extension is even more spacious. A crewcab seating a total of five is also optionally available. The low entry height of the Atego up to 12 t with a low frame makes it much easier on those whose work requires them to climb in and out of the cab frequently. And the wide-opening doors, as well as grab handles on both sides, make getting in and out much safer too. Having taken a seat, the driver will be impressed by the cockpit with its numerous stowage facilities and easy through-cab access to the co-driver's side.



Practical and convenient: the low single-step entrance with lighting as standard, a spacious workplace with numerous practical stowage options and good visibility make the Atego a comfortable, safe, reliable helper in the building materials industry



The dimensions of the standard-specification “Distribution” cockpit are such that it enables extremely convenient through-cab access in conjunction with the short engine tunnel of the 4-cylinder engines, while still featuring plenty of handy stowage space

Another reason to get on board more often

The Atego helps make every job easier – with its spaciousness, user-friendliness and a host of practical details, all of which contribute to ensure that motivation never gets lost on the way.

Work is altogether more pleasant – in conjunction with the comfortable driver's seat and the graphics-capable instrument cluster, the multifunction steering wheel, which is also optionally available in leather, ensures optimum working conditions. Everything is ergonomically arranged and easy to reach – from the large stowage compartment on the instrument cluster with a cup and drinks holder for the driver and co-driver to the coolbox. Situated on the engine tunnel and with a volume of around 23 l, the latter is available as an option and offers plenty of room for cool drinks and fresh food. The Atego is equipped with the cruise and braking speed control, which is operated via the right-hand steering-column lever. A powerful, individually adjustable heating and ventilation system sees to it that the cab has the right working climate. And the optional manually controllable air conditioning system or the hot-air auxiliary heating increase comfort levels even further.



The Atego's comfortable seats have integral head restraints¹⁾ and they all boast flat-weave fabric or velour with the "Brasao" design. From 12 t the Atego is equipped with the standard air-sprung suspension seat for the driver²⁾, offering yet more ride comfort



The clothes rail³⁾ brings more order to the S-cab and the S-cab with a rear panel extension. The comfort air-sprung suspension seat is optionally available for the driver and co-driver, with a wide range of adjustment options such as lumbar support and side contour adjustment



The optionally available, ex-factory user-friendly CB radio is located above the windscreen. The digital tachograph, the optional radio with an integral Bluetooth hands-free system as well as the FleetBoard® system, can all be comfortably installed here as well



The door operating panel groups together the controls for mirror adjustment and mirror heating, the switches for the power windows, the central locking system and the optionally available extended central locking system. The eyeball-type air outlets prevent misting-up of the side windows, and provide cool air for the driver in summer



As an option high and low stowage boxes are available, offering even more space within the driver's reach. In addition to cup and bottle holders, the high stowage compartment now also features a folding table that can be used as a writing surface, for instance



The instrument cluster, refined with chrome surrounds, and graphics-capable display shows information on the operating status in symbol or text form. In conjunction with a manual gearshift, a variable, green engine speed range is integrated as standard, helping to save fuel



Advantages at a glance

- Two cab and three cockpit variants ensure optimum adaptation to every application
- Low entry height and good all-round visibility
- Ergonomically-shaped seats with multiple adjustment possibilities to give the driver a relaxed seating position
- Multifunction steering wheel as standard, optionally available in leather
- Graphics-capable instrument cluster with variable, green rev counter range
- Ease of operation thanks to controls located according to ergonomic criteria
- Radios with integral Bluetooth hands-free system as special equipment
- Powerful, individually adjustable heating and ventilation system
- Manually adjustable air conditioning system and hot-air auxiliary heating optionally available
- Numerous practical stowage spaces and compartments
- Optional coolbox with a volume of approx. 23 l
- Clothes rail³⁾ in the S-cab

¹⁾ Not in conjunction with the centre seat and folding fixed co-driver's seat

²⁾ Also available for the co-driver as an option

³⁾ Not in conjunction with centre seat



A joy for both driver and accountant

The Atego can be relied upon to meet the challenges of day to day work in the construction industry, thanks to its tried and tested robust technology, and the wealth of experience of Mercedes-Benz.

Numerous factors contribute towards the economic efficiency of the Atego: among them are its frugal, highly reliable BlueTec® engines. The Telligent® engine system optimises fuel usage, while application-specific transmission and axle combinations support low-consumption operation. As does the optional Telligent® automatic gearshift, which also relieves the strain on the driver. And the motor start/stop system¹⁾, available as an option, makes the Atego even more economical, by reducing fuel consumption and lowering CO₂ emissions further. Plus, of course, the particularly long maintenance intervals and the robust design and build of all the relevant vehicle components. In short: on the Atego every single detail helps make life easier. And that goes for the accounting department, too.

¹⁾ Standard for Atego in conjunction with manual gearshift.
Not available with other transmission options



The optional motor start/stop system¹⁾ can contribute towards lower consumption and CO₂ emissions. It switches off the engine, for instance, at traffic lights or in stop-and-go traffic, starting up again automatically as soon as things begin moving



All Atego trucks come complete with Mercedes-Benz SCR diesel technology and sport BlueTec® lettering. As far as you're concerned this translates as follows: long maintenance intervals, low fuel consumption and thus Euro 5 compliance

Specialists for the construction industry

Reliable, powerful engines, with application-specific transmissions and gearshifts fine-tuned to each other, all come together in the Atego to provide the base for its successful operation in the construction industry.

Low consumption and consequently low particulate emissions as well as a low CO₂ output – these are the fundamental benefits of the Atego's highly reliable BlueTec® 5 engines. And for all those for whom Euro 5 is not enough, as an option the Atego¹⁾ can also be supplied with engines which meet the more stringent EEV emissions standard²⁾. This can contribute to further reduced particulate emissions. The Telligent® engine system optimises fuel consumption by regulating the fuel amount for every individual cylinder depending on the driving situation and relevant engine data. Three standard-fit weight-optimised and optimally designed 6-speed transmissions in the Atego ensure that the engine output is transferred to the road surface with as little loss as possible. On the models with the **188 kW (256 hp)** and **210 kW (286 hp)** engine variants, this task is performed by a 9-speed direct-drive transmission with a mechanical/hydraulic gearshift.

¹⁾ Atego from **130 kW (177 hp)** to **210 kW (286 hp)**

²⁾ Enhanced Environmentally Friendly Vehicle



The 4.8-litre, 4-cylinder in-line engine delivers **160 kW (218 hp)**, well within the output range you would actually expect from a 6-cylinder engine. A further benefit of this engine: it is a good 100 kg lighter than a 6-cylinder engine with a comparable output

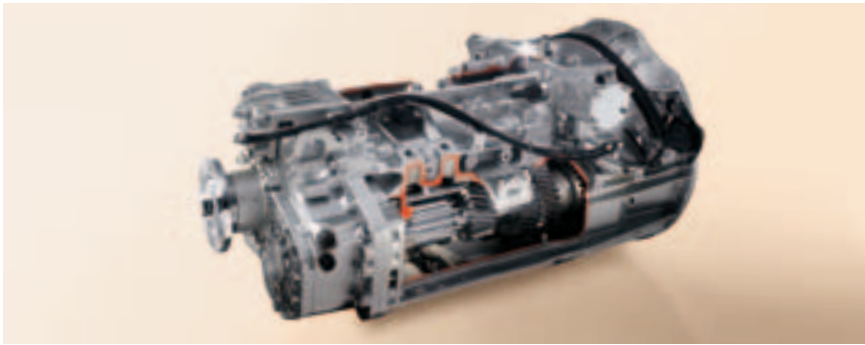

The 9-speed (eight gears, one crawler gear) direct-drive transmission which is standard on the Atego from 188 kW (256 hp) upwards, with its optimised transmission ratio in crawler and reverse gear, enables precise manoeuvring. Furthermore, it allows smooth gearshifts and, in conjunction with the HL 2 and HL 4 axles it virtually always enables an optimum powertrain configuration



In the Atego the optionally available Telligent[®] automatic gearshift³⁾ relieves the strain on the driver. However, the driver can intervene manually at any time in anticipation of a situation on the road ahead

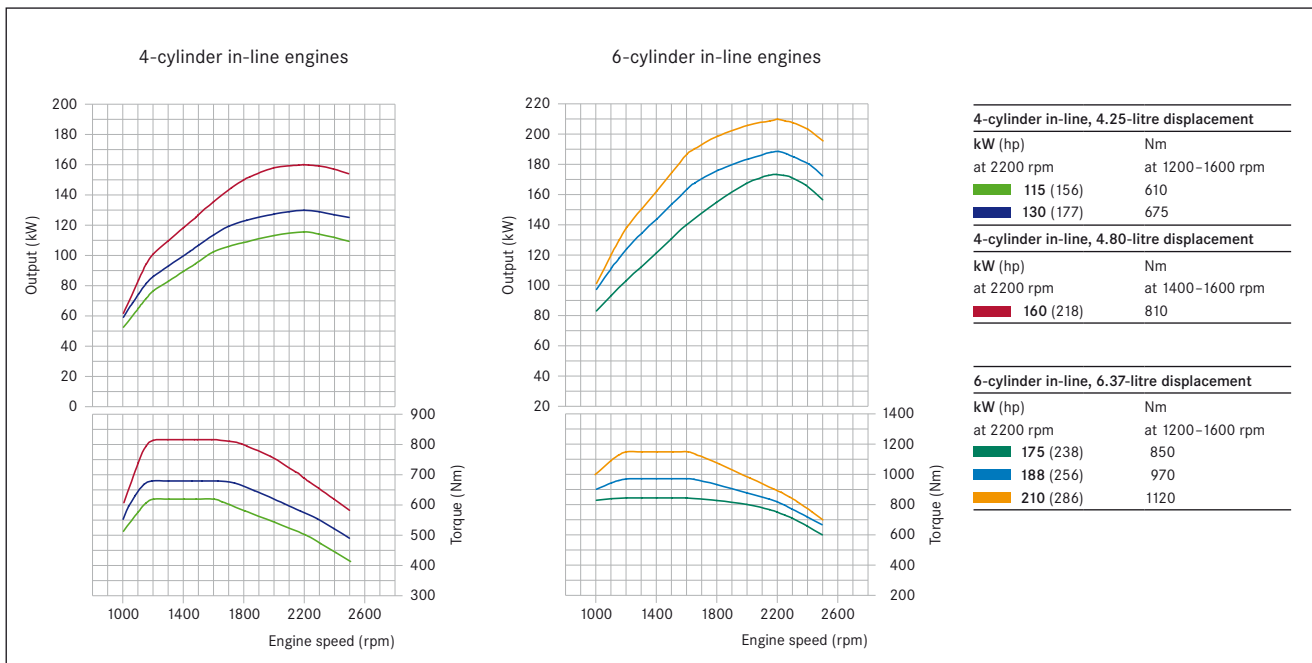

There are six engines available for the Atego, spanning the range from 115 kW (156 hp) to 210 kW (286 hp). Configured to deliver their peak torque starting in the economical low speed range – meaning in practical terms a power delivery which will delight even the most experienced drivers



Advantages at a glance

- Six economical, powerful BlueTec[®] engines with a low level of CO₂ emissions
- Atego¹⁾ vehicles that meet the stringent EEV emissions standard²⁾ are available as an option
- Telligent[®] engine system for low fuel consumption and high power efficiency
- Motor start/stop system⁴⁾ as an option for even lower consumption and fewer emissions
- Application-specific transmissions and gearshifts
- Optional Telligent[®] automatic transmission³⁾ for economical driving and to relieve the strain on the driver

³⁾ For Atego with 6-speed transmission and engine output from 115 kW (156 hp) to 175 kW (238 hp)

⁴⁾ Standard for Atego in conjunction with manual gearshift. Not available with other transmission options



A tough cookie

In the construction materials industry the demands made on chassis and suspension aren't just hard; they are also extremely varied. That's why we built the Atego to cut a good figure on the construction site. And in town as well.

The frame of the Atego is robust and equal to all demands placed on it by everyday operation. The frame members are available in thicknesses of 5.0 and 7.0 mm, depending on the vehicle model. This ensures a high bending strength and torsional stiffness.

In respect of its suspension the Atego leaves nothing to be desired. Whether it's steel, steel and air or full air

suspension – the Atego always has the right solution for your transport requirements.

Standard equipment for the Atego includes maintenance-free parabolic springs and front-axle anti-roll bars.

Tippers and all-wheel-drive vehicles are additionally equipped with rear axle anti-roll bars. Tippers and vehicles with a crane, subjected to high one-sided loads,

can also be fitted with optional high-load anti-roll bars if these are not part of the standard equipment.



Through their low frictional loss and high smoothness of operation, the single-reduction HL4 hypoid rear axles facilitate fuel-efficient operation. In addition, numerous axle ratios make possible an individual adaptation to specific transport tasks



The bodybuilder interface allows bodybuilders easy, uncomplicated access to the Atego's electrical systems. This saves time and costs and makes for easier "communication" between the vehicle and body



Standard equipment for the steel-sprung Atego includes weight-optimised single and multi-leaf parabolic springs as well as maintenance-free rubber molecular bearings: this saves on maintenance costs and ensures superlative ride comfort even on unsurfaced roads or gravel tracks



High-load anti-roll bars can be installed on vehicles with high attachments and a high centre of gravity in order to reduce front-axle spring compression, thus increasing ride comfort and handling safety



The frame of the Atego is weight-optimised and combines robustness with good body-mounting ability. Thanks to the frame's 50 mm hole matrix, bodies and other additional and peripheral units can be mounted rapidly and cost-effectively. And all this without damaging its exceptional corrosion protection – the cathodic dip-priming



Advantages at a glance

- Weight-optimised frame with a 50 mm hole pattern, ideal for mounting bodies
- High-performance steel suspension for tippers and all-wheel-drive vehicles
- Different load placed on front and rear springs for an individual adaptation to specific transport requirements
- Bodybuilder interface for low body mounting costs and straightforward connection of all electrical systems
- Robust, low-maintenance, consumption-reducing drive axles



The Atego – model overview		816	818	822	824	918	922	924
Engine (BlueTec® 5)	No. of cylinders	IL 4 ¹⁾	IL 4 ¹⁾	IL 4 ¹⁾	IL 6 ¹⁾	IL 4 ¹⁾	IL 4 ¹⁾	IL 6 ¹⁾
	kW (hp)	115 (156)	130 (177)	160 (218)	175 (238)	130 (177)	160 (218)	175 (238)
	Max. output (rpm)	2200	2200	2200	2200	2200	2200	2200
	Nm	610	675	810	850	675	810	850
	Max. torque (rpm)	1200 – 1600	1200 – 1600	1200 – 1600	1200 – 1600	1200 – 1600	1200 – 1600	1200 – 1600
Transmission	G56-6 (6 gears)	•	•	-	-	•	-	-
	G60-6 (6 gears)	x	x	-	-	x	-	-
	G85-6 (6 gears)	-	-	•	•	-	•	•
	G131-9 (8 + crawler)	-	-	-	-	-	-	-
Cab	S	•	•	•	•	•	•	•
	S extended	x	x	x	x	x	x	x
Wheelbase in mm	Chassis cab	3020	3020	3020	3020	3020	3020	3020
		3320	3320	3320	3320	3320	3320	3320
		3620	3620	3620	3620	3620	3620	3620
		4220	4220	4220	4220	4220	4220	4220
		4820	4820	4820	4820	4820	4820	4820
Permitted axle loads and weights in kg	Permitted front axle load	3400	3400	3400	3400	4000	4000	4000
	Permitted rear axle load	5000	5000	5000	5000	6200	6200	6200
	Permitted gross vehicle weight	7490	7490	7490	7490	9500	9500	9500
	Permitted gross combination weight	18,000	18,000	18,000	18,000	21,000	21,000	21,000

The Atego – model overview		1018	1022	1024	1218	1222	1224	1229	
Engine (BlueTec® 5)	No. of cylinders	IL 4 ¹⁾	IL 4 ¹⁾	IL 6 ¹⁾	IL 4 ¹⁾	IL 4 ¹⁾	IL 6 ¹⁾	IL 6 ¹⁾	
	kW (hp)	130 (177)	160 (218)	175 (238)	130 (177)	160 (218)	175 (238)	210 (286)	
	Max. output (rpm)	2200	2200	2200	2200	2200	2200	2200	
	Nm	675	810	850	675	810	850	1120	
	Max. torque (rpm)	1200 – 1600	1200 – 1600	1200 – 1600	1200 – 1600	1200 – 1600	1200 – 1600	1200 – 1600	
Transmission	G56-6 (6 gears)	-	-	-	-	-	-	-	
	G60-6 (6 gears)	•	-	-	•	-	-	-	
	G85-6 (6 gears)	-	•	•	-	•	•	-	
	G131-9 (8 + crawler)	-	-	x	-	-	x	•	
Cab	S	•	•	•	•	•	•	•	
	S extended	x	x	x	x	x	x	x	
Wheelbase in mm	Chassis cab	3020	3020	3020	-	-	-	-	
		3320	3320	3320	3560	3560	3560	3560	
		3620	3620	3620	4160	4160	4160	4160	
		4220	4220	4220	4760	4760	4760	4760	
		4820	4820	4820	5360	5360	5360	5360	
Permitted axle loads and weights in kg	Chassis cab	5960	5960	5960	6260	6260	6260	6260	
		6260	6260	6260	6260	6260	6260	6260	
		Permitted front axle load	4000	4000	4000	4900	4900	4900	4900
		Permitted rear axle load	7000	7000	7000	8100	8100	8100	8100
		Permitted gross vehicle weight	10,500	10,500	10,500	11,990	11,990	11,990	11,990
Permitted gross combination weight	21,000	21,000	21,000	21,000	21,000	21,000	21,000		

• Standard x Optional - Not available ¹⁾ IL: in-line engine ²⁾ Tipper Chassis (K) ³⁾ 17,000 kg with 6260 wb All Wheel Drive, Low Frame and Roadsweeper models are available on request

The Atego – model overview		1318	1322	1324	1329	1518	1522
Engine (BlueTec® 5)	No. of cylinders	IL 4 ¹⁾	IL 4 ¹⁾	IL 6 ¹⁾	IL 6 ¹⁾	IL 4 ¹⁾	IL 4 ¹⁾
	kW (hp)	130 (177)	160 (218)	175 (238)	210 (286)	130 (177)	160 (218)
	Max. output (rpm)	2200	2200	2200	2200	2200	2200
	Nm	675	810	850	1120	675	810
	Max. torque (rpm)	1200 – 1600	1200 – 1600	1200 – 1600	1200 – 1600	1200 – 1600	1200 – 1600
Transmission	G56-6 (6 gears)	-	-	-	-	-	-
	G60-6 (6 gears)	•	-	-	-	•	-
	G85-6 (6 gears)	-	•	•	-	-	•
	G131-9 (8+ crawler)	-	-	x	•	-	-
Cab	S	•	•	•	•	•	•
	S extended	x	x	x	x	x	x
Wheelbase in mm	Chassis cab	3260 ²⁾	3260 ²⁾	3260 ²⁾	-	3260 ²⁾	3260 ²⁾
		3560	3560	3560	3560	3560	3560
		4160	4160	4160	4160	4160	4160
		4760	4760	4760	4760	4760	4760
		5360	5360	5360	5360	5360	5360
		-	-	-	-	-	-
	6260	6260	6260	6260	6260	6260	
Permitted axle loads and weights in kg	Permitted front axle load	5100	5100	5100	5100	5300	5300
	Permitted rear axle load	9300	9300	9300	9300	10,500	10,500
	Permitted gross vehicle weight	13,500	13,500	13,500	13,500	15,000	15,000
	Permitted gross combination weight	21,000 ³⁾	21,000	28,000	28,000	21,000	21,000

The Atego – model overview		1524	1529	1618	1622	1624	1629
Engine (BlueTec® 5)	No. of cylinders	IL 6 ¹⁾	IL 6 ¹⁾	IL 4 ¹⁾	IL 4 ¹⁾	IL 6 ¹⁾	IL 6 ¹⁾
	kW (hp)	175 (238)	210 (286)	130 (177)	160 (218)	175 (238)	210 (286)
	Max. output (rpm)	2200	2200	2200	2200	2200	2200
	Nm	850	1120	675	810	850	1200
	Max. torque (rpm)	1200 – 1600	1200 – 1600	1200 – 1600	1200 – 1600	1200 – 1600	1200 – 1600
Transmission	G56-6 (6 gears)	-	-	-	-	-	-
	G60-6 (6 gears)	-	-	•	-	-	-
	G85-6 (6 gears)	•	-	-	•	•	-
	G131-9 (8+ crawler)	x	•	-	-	x	•
Cab	S	•	•	•	•	•	•
	S extended	x	x	x	x	x	x
Wheelbase in mm	Chassis cab	3260 ²⁾	-	3260 ²⁾	3260 ²⁾	3260 ²⁾	-
		3560	3560	3560	3560	3560	3560
		4160	4160	4160	4160	4160	4160
		4760	4760	4760	4760	4760	4760
		5360	5360	5360	5360	5360	5360
		-	-	-	-	-	-
	6260	6260	6260	6260	6260	6260	
Permitted axle loads and weights in kg	Permitted front axle load	5300	5300	6100	6100	6100	6100
	Permitted rear axle load	10,500	10,500	10,500	10,500	10,500	10,500
	Permitted gross vehicle weight	15,000	15,000	16,000	16,000	16,000	16,000
	Permitted gross combination weight	28,000	28,000	16,000	16,000	16,000	16,000

The Atego – cab types

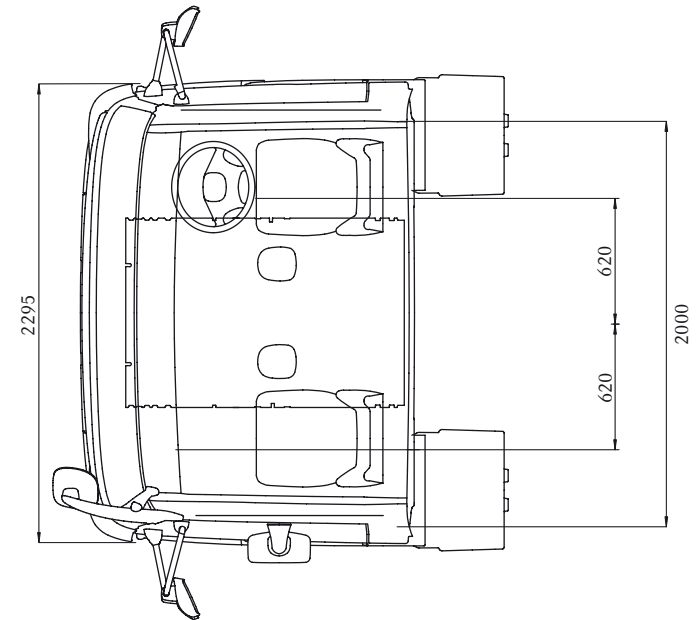
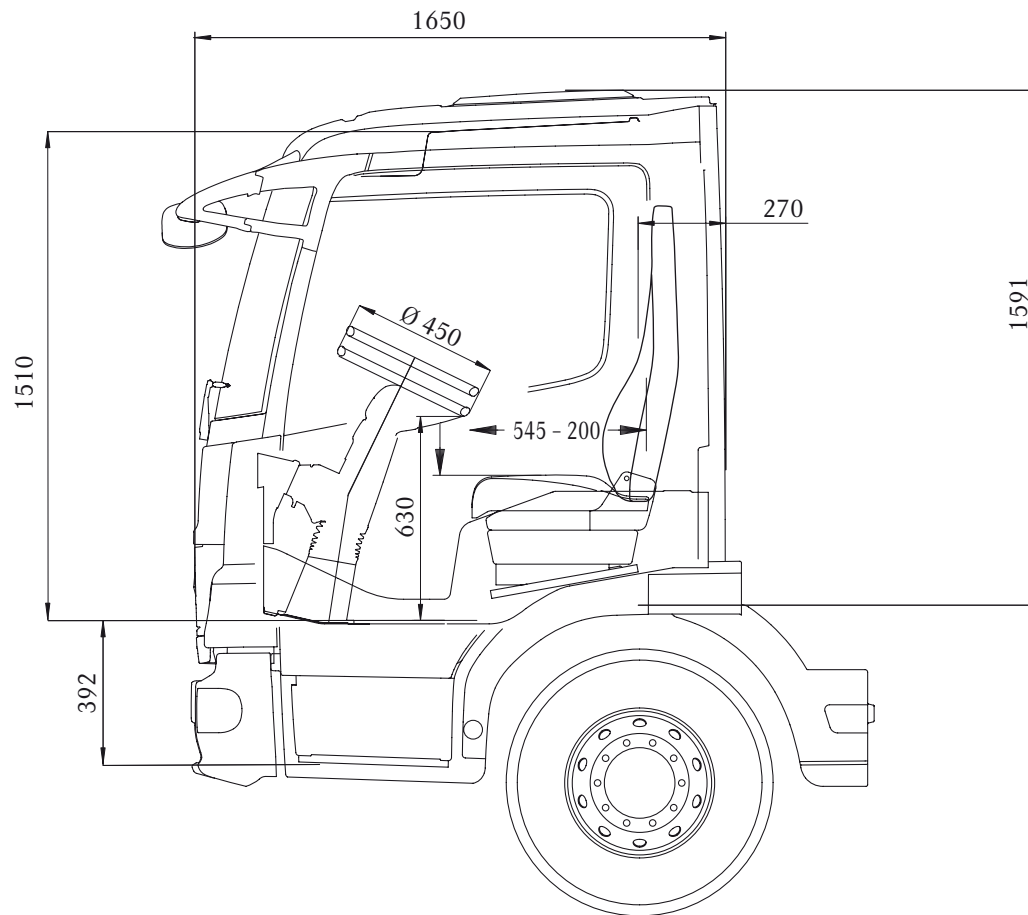

S-cab

Exterior width:	2295 mm
Exterior length:	1650 mm
Interior width:	2000 mm
Interior height:	1510 mm

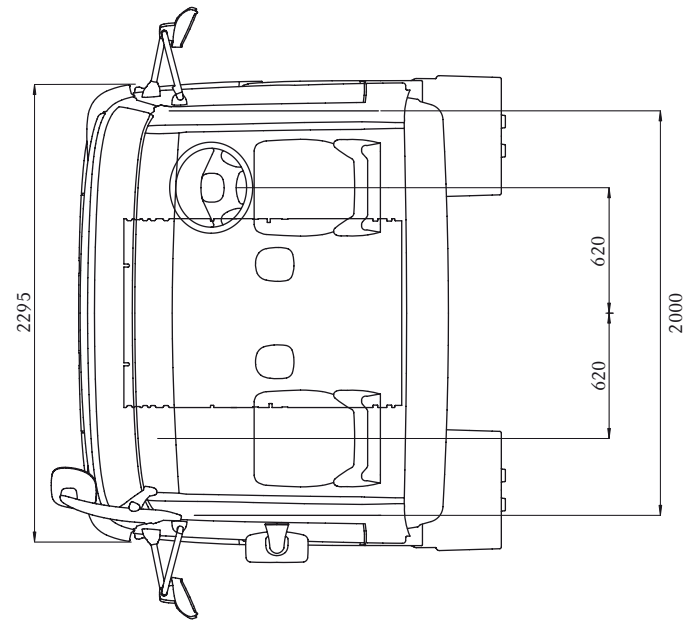
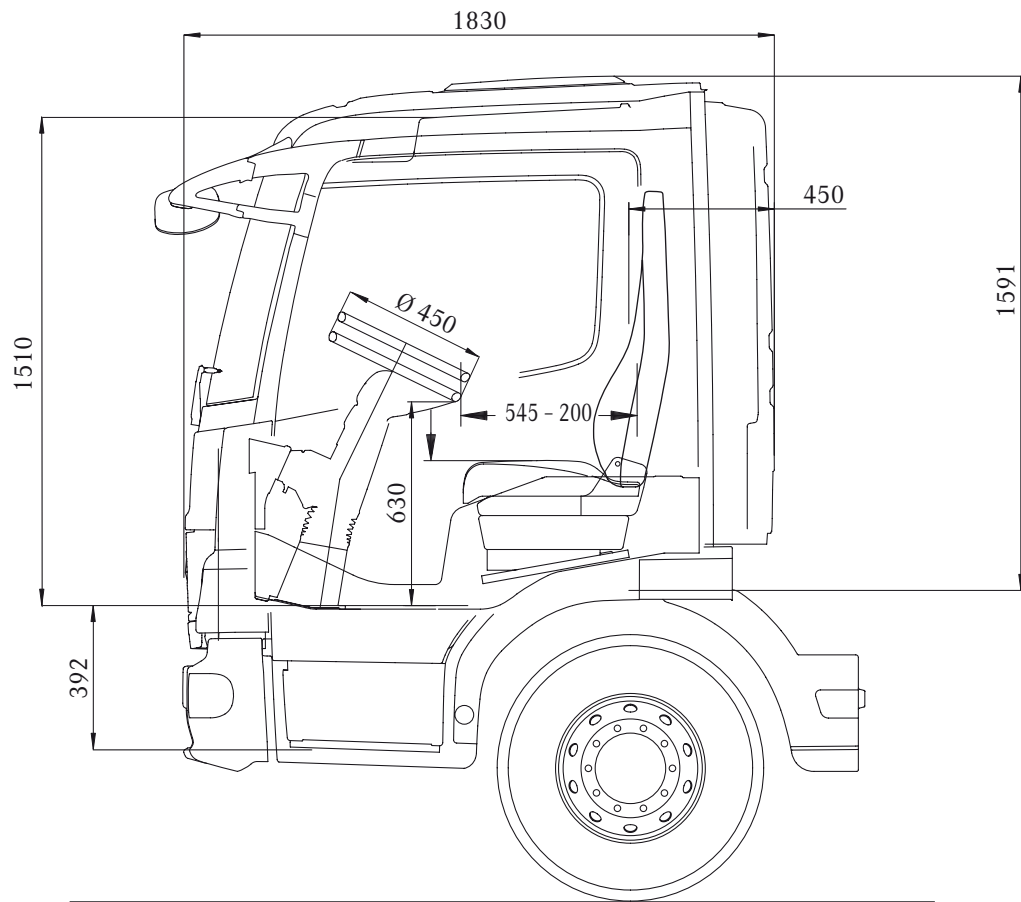

S-cab
with extended rear panel

- Exterior width: 2295 mm
- Exterior length: 1830 mm
- Interior width: 2000 mm
- Interior height: 1510 mm

A lightweight that really pulls its weight. The Axor

Steel and ideas – the light, robust design of the Axor shows that toughness and low kerb weight are not contradictory. And as for strength, application specificity and diversity of variants for everyday operation, it leaves nothing to be desired.

The Axor helps you make light work of even the toughest challenges in the construction industry and the building materials industry. With its high payload capacity, two application-based cab variants and its robust, reliable technology, it makes no compromises in the weight class from 18 to 32 t, be it transporting construction material on the road, or in light and medium off-road operations requiring plenty of traction. Specifically-tailored powertrains ensure the excellent economic efficiency of the Axor – for example with the powerful, reliable and frugal BlueTec® engines with long maintenance intervals and, as an option, also with the Mercedes PowerShift¹⁾ automatic transmission. As an option the Axor²⁾ is available with engines which meet the stringent EEV emissions standard³⁾. And lots of practical details in the cab ensure increased ride and working comfort. Of course, it is available in countless variants: apart from tippers and concrete mixers, thanks to the dropsiders and all-wheel-drive tippers the Axor can move mountains in the building materials industry. On two, three or four axles.

¹⁾ For Axor concrete mixers from 265 kW (360 hp)

²⁾ Axor with 210 kW (286 hp) and 240 kW (326 hp)

³⁾ Enhanced Environmentally Friendly Vehicle







Snug as a glove: the cab

Whether it's the S-cab or the S-cab with a rear panel extension – both Axor cab versions have been carefully thought out from top to toe, and can be optimally tailored to their specific application and to the driver's requirements. Hop in!

Everything is just right here – you reach the ergonomically designed workplace via safe, slip-resistant steps. Standard equipment for tippers and concrete mixers includes a flexible bottom step on each side of the vehicle. Tippers have the extremely practical option of a lateral step with a grab handle for accessing the skip from the cab. The cabs are equally impressive inside, with their ergonomics and ease of operation, for instance. And with equipment and appointments such as the multifunction steering wheel and the optional stowage compartments for the engine tunnel. The large windows and mirrors ensure excellent all-round visibility. The heated rear-view and exterior mirrors can be switched on and off manually to prevent them from misting or icing over or to stop the burning-on of dirt particles. In short: the Axor shows how a well-thought-out working environment supports and motivates the driver.



The compact S-cab is part of the standard specification for all models up to 240 kW (326 hp). The standard cab for concrete mixers and tippers with an output of 265 kW (360 hp) or above is the S-cab with a rear panel extension¹⁾, which has 180 mm of extra stowage space behind the seats

¹⁾ The S-cab with a rear panel extension is available as an option for Axor trucks with an output of up to 240 kW (326 hp)

Helping to make work a little easier

Stress-relieving comfort, ease of operation and application-based details – welcome to the Axor.

The Axor makes many things easier – from the comfortable driver's seat to the steering wheel, which is also available in leather as an option, and from the graphics-capable instrument cluster refined with chrome surrounds to the open stowage pockets in the doors, which include a holder for a 1.5 l bottle. The best possible lighting conditions in the Axor are ensured, for example, by two anti-glare dimmable lamps and cockpit lighting with a bright reading light. And in order for the climate to be a pleasant one at all times, the Axor features an efficient air-controlled heating system. An optional manually-regulated air conditioning system and particularly quiet hot-air auxiliary heating enhance comfort even further. Other features available include the truck navigation system from Mercedes-Benz, helping you reach your destination sooner thanks to truck-specific route guidance with DVD navigation and a TMC function.



All the seats in the Axor have integral head restraints¹⁾ and are fitted with flat-weave fabric or velour featuring the "Brasao" design. The optionally available comfort suspension seat for the driver's and co-driver's side enhances seating comfort and is conducive to relaxed, safe driving



Standard equipment for tippers, concrete mixers and all-wheel-drive vehicles includes a flexible bottom step which recoils upwards upon contact with an obstacle, thus protecting itself against damage. The entrance to the cab is illuminated on all Axor vehicles



Always refreshing to see: the optional coolbox. It has a removable liner which is easy to clean, features an infinitely adjustable temperature setting, is illuminated on the inside and with a volume of approx. 23 l it offers plenty of room for provisions and drinks



The standard-specification cockpit in the Axor: apart from the harmoniously curved basic shape with ergonomically positioned controls this cockpit is characterised by its extended instrument support offering plenty of generous stowage facilities. Two further cockpit variants are optionally available. The driver information system, radio and telephone can be operated simply and safely via the standard-fit multifunction steering wheel, for instance. As an option the multifunction steering wheel is also available in leather



The digital tachograph and the optionally available components, such as the radio with a Bluetooth hands-free system, navigation device, CB radio or FleetBoard® are located above the windscreen. In addition, two open compartments on the co-driver's side offer extra stowage space



The S-cab and the S-cab with an extended rear panel are available with a clothes rail²⁾. Fitted to the rear panel of the cab, it allows jackets and raincoats, for instance, to be hung up tidily, keeping them within reach at all times



Advantages at a glance

- Three application-based cockpit variants
- Ergonomic, standard air-sprung suspension seat for the driver, optional comfort air-sprung suspension seat
- Air conditioning and hot-air auxiliary heater both available as special equipment
- Standard-fit pneumatically adjustable multifunction steering wheel, in leather as an option
- Graphics-capable instrument cluster refined with chrome surrounds
- Radios with integral Bluetooth hands-free system as special equipment
- Optional Mercedes-Benz truck navigation system
- Stowage compartments for the engine tunnel or coolbox with volume of approx. 23 l as an option
- Clothes rail in S-cab and S-cab with extended rear panel
- Optional sunblind for driver's and co-driver's side

¹⁾ Not in conjunction with the centre seat and folding fixed co-driver's seat

²⁾ Not in conjunction with centre seat





Exceptional results – not only in terms of payload

Low kerb weight, low costs and robust, reliable technology – these are the characteristics that make the Axor so economically efficient in construction industry transportation.

More load, less consumption – this is what the robust, weight-optimised design of the Axor and its frugal BlueTec® engines stand for. The motor start/stop system¹⁾, the Telligent® maintenance system²⁾ and special drive-system configurations – for instance for operations involving a high proportion of on-road driving – all increase economic efficiency additionally. Tippers and concrete mixers are driven by powerful engines with an output of up to 315 kW (428 hp). And for concrete mixers from 265 kW (360 hp) the Mercedes PowerShift automatic transmission is available as an option. Not to mention the fact that robust, reliable technology ensures first-rate results – from the functionally styled cab to different transmission and axle combinations – the Axor combines important advantages that pay dividends day after day in the construction industry; see for yourself!

¹⁾ Standard for Axor up to 240 kW (326 hp) in conjunction with manual gearshift. Not available with other transmission options

²⁾ Up to 240 kW (326 hp) standard specification, above 240 kW optionally available in conjunction with Telligent® braking system



As an option, for example for tippers and concrete mixers driven mainly on firm road surfaces, light-alloy wheels are available. Not only do these look good, through their light weight, they also contribute to increasing the vehicle's payload. For maximum payload the concrete mixer is also available with a payload package and numerous weight-optimising measures. These include the aluminium compressed-air reservoirs and a lighter main tank

Get more back on what you invest

No matter what it is you have to transport, the Axor ensures that you can do it with the greatest economy. With application-based, durable technology. And up to **315 kW** (428 hp).

The Axor's economical, reliable 6-cylinder in-line engines can successfully meet just about every challenge posed by work in the construction industry. For all those for whom Euro 5 isn't low-emission enough, as an option the Axor¹⁾ can already be delivered as a vehicle that complies with the more stringent EEV emissions standard²⁾. All the engines are equipped with the Telligent[®] engine system, which ensures efficient combustion. And the motor start/stop system³⁾ also saves fuel, thus further reducing CO₂ emissions, by automatically switching off the engine, and then switching it on again, for instance when waiting at traffic lights. For application-based drive-system configurations, the 175 kW (238 hp) Axor vehicles are equipped with a 6-speed transmission. And in conjunction with a 16-speed overdrive transmission and the especially robust HL 7 planetary hub reduction axle, the Axor from 210 kW (286 hp) is also optionally available with the Telligent[®] gearshift: just nudge the selector lever and de-clutch! That's how effortless and comfortable gearshifting can be.



Lots of power for the 4-axle tippers and concrete mixers: the 6-cylinder in-line engines with a displacement of 12 litres deliver between **265 kW** (360 hp) and **315 kW** (428 hp), depending on the model. For the construction site, this spells lots of power where it is needed

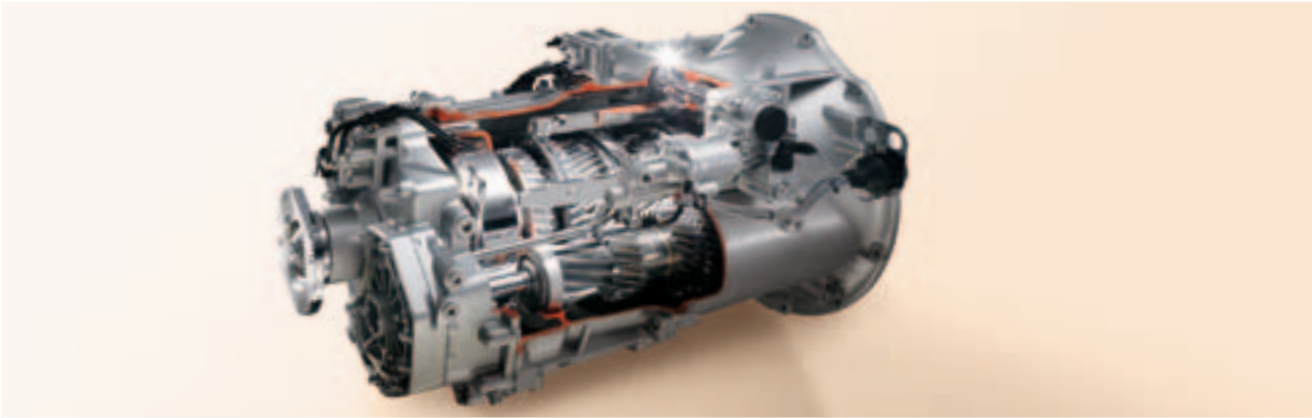

The 9-speed direct-drive transmission (eight gears, one crawler gear) with hydraulic gearshift and a single-plate clutch is part of the standard equipment for 210 kW (286 hp) and 240 kW (326 hp) Axor models. The transmission impresses with precise gear shifts, fast connections and smooth gear changes. And the gear ratio steps are perfectly tailored to the specific application, ensuring optimum torque transfer – when on the road, off-road or manoeuvring

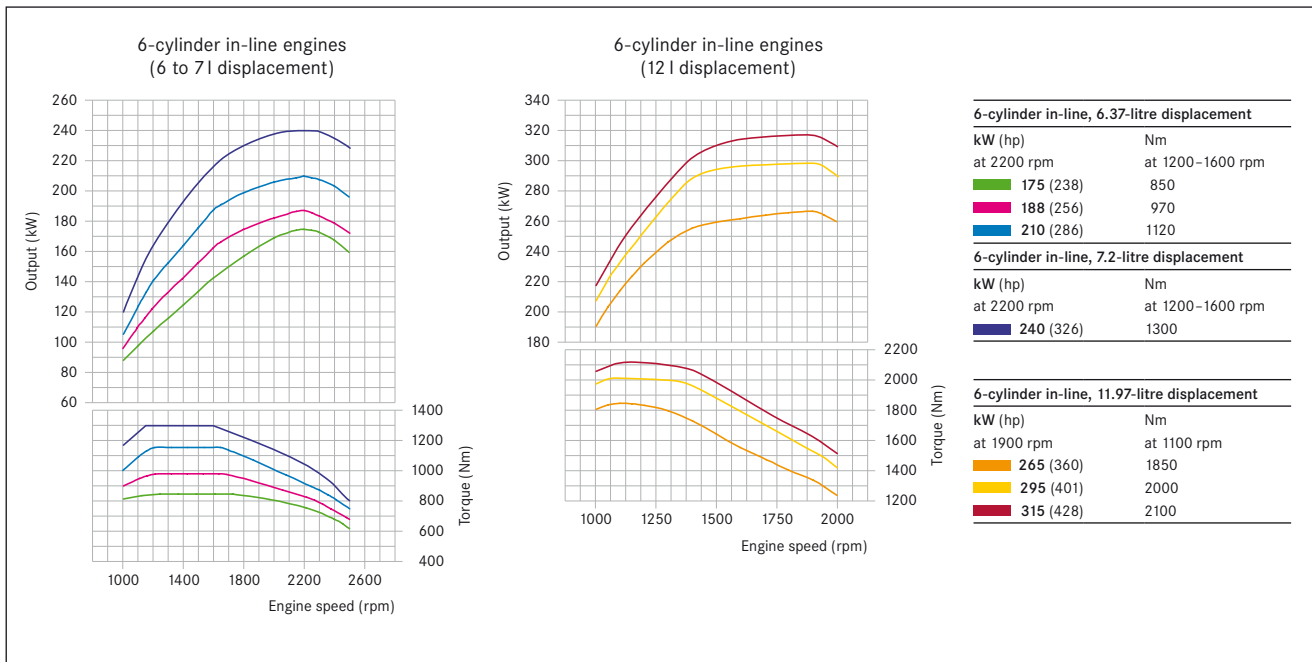

The Axor's BlueTec® engines are available with a displacement of 6, 7 or 12 litres and in seven output levels from 175 kW (238 hp) to 315 kW (428 hp), providing an economically efficient basis for every possible operation and application in the construction industry. The particularly efficient combustion contributes towards low consumption and low CO₂ emissions



Advantages at a glance

- Fuel-efficient, reliable BlueTec® engines with high torque at low engine speeds
- As an option the Axor¹⁾ is also available as a vehicle that complies with the stringent EEV emissions standard²⁾
- Motor start/stop system³⁾ for lower consumption and lower CO₂ emissions
- Telligent® engine system for low fuel consumption and low pollutant emissions
- Smooth 6- or 9-speed direct-drive transmission with optimised torque transfer
- Convenient, powertrain-protecting Telligent® automatic gearshift system optionally available

¹⁾ Axor with 210 kW (286 hp) and 240 kW (326 hp)

²⁾ Enhanced Environmentally Friendly Vehicle

³⁾ Standard for Axor up to 240 kW (326 hp) in conjunction with manual gearshift. Not available with other transmission options



A lightweight – and still ready to take on heavy loads

Low kerb weight and at the same time great robustness? The Axor shows how this is done: with vehicle components that perform better and weigh less. And with all the experience and knowledge of Mercedes-Benz.

Numerous details show that all the practical knowledge of the construction industry branch is present in the Axor – the longitudinal members of the lightweight yet sturdy parallel frame come in the two material thicknesses 8 and 9.5 mm. The frame thus combines important advantages, creating the basic requirement for the Axor's high payload.

Yet another example is the stabiliser link that is installed on air-sprung Axor models with an HL 6 drive axle. As well as keeping kerb weight low, its ability to stabilise body roll, together with its precise wheel location, translate into optimum handling characteristics.

All Axor trucks are equipped with dual-leaf parabolic springs on the front axle as standard. The rear axle is outfitted with leaf spring packets of two to four leaves, depending on the vehicle weight. For trucks with extraordinary front or rear loads, reinforced leaf springs can be provided as an option.



The parameterisable special module (PSM) is an interface for bodybuilders. It enables data exchange between the vehicle electronics and attachments, as well as the external control of vehicle functions



The low-maintenance, robust HL 4 hypoid rear axle is installed on 4-axle trucks in conjunction with the HD 4 through-drive axle as a tandem-axle assembly. Now produced using metal forming technology, the axle has a lower unladen weight, and a greater load-bearing capacity



The frame's 50 mm hole matrix allows swift, cost-effective mounting or relocation of bodies and other units. And since it eliminates the need for extra drilling, the outstanding corrosion protection – provided by the cathodic dip priming process – is not damaged



The motor start/stop system¹⁾ can contribute towards lower consumption and CO₂ emissions. It switches off the engine, for instance, at traffic lights or in stop-and-go traffic, starting up again automatically as soon as things begin moving



The Telligent[®] maintenance system²⁾ determines the best time for a service by registering the actual amount of wear. Hence oil changes are not determined by the mileage but by the condition of the oil



The optionally available comfort cab suspension enhances ride comfort. Its additional longitudinal mountings and rubber bearings dampen impacts and vibrations caused, for example, by uneven road surfaces

i Advantages at a glance

- Weight-optimised, robust frame, ideal for mounting bodies, with a 50 mm hole matrix
- Robust, durable steel suspension with outstanding corrosion protection
- Light, fuel-saving HL 4 hypoid rear axle with single-stage reduction as standard
- Telligent[®] maintenance system²⁾ for long, operation-optimising maintenance intervals
- Telligent[®] level control for raising and lowering the frame
- Lightweight components for a lower kerb weight and higher payload as special equipment
- Bodybuilder interface for cost-effective attachment of bodies

¹⁾ Standard for Axor up to 240 kW (326 hp) in conjunction with manual gearshift. Not available with other transmission options

²⁾ Up to 240 kW (326 hp) standard specification, above 240 kW optionally available in conjunction with Telligent[®] braking system



The Axor – model overview		1824	1829	1833	2629	2633
Engine (BlueTec® 5)	No. of cylinders	IL 6 ¹⁾	IL 6 ¹⁾	IL 6 ¹⁾	IL 6 ¹⁾	IL 6 ¹⁾
	kW (hp)	175 (238)	210 (286)	240 (326)	210 (286)	240 (326)
	Max. output (rpm)	2200	2200	2200	2200	2200
	Nm	850	1120	1300	1120	1300
	Max. torque (rpm)	1200 – 1600	1200 – 1600	1200 – 1600	1200 – 1600	1200 – 1600
Transmission	G85-6 (6 gears)	•	–	–	–	–
	G131-9 (8 + crawler)	x	•	•	•	•
	G211-16 (16 gears)	–	K x	K x	x	x
Cab	S	•	•	•	•	•
	S extended	x	x	x	x	x
Wheelbase in mm	Tipper (K)	–	–	–	3300	3300
		3600	3600	3600	3600	3600
		3900	3900	3900	3900	3900
	All-wheel-drive chassis/cab (A)	–	4200	4200	–	–
				4500	4500	
	All-wheel-drive tipper (AK)	3600	3600	3600	–	–
		3900	3900	3900		
	Concrete mixer (B)	–	–	–	3300	3300
					3900	3900
	Permitted axle loads and weights in kg	Permitted front axle load	7500	7500	7500	8000
Permitted rear axle load		11,500	11,500	11,500	2x10,000	2x10,000
Permitted gross vehicle weight		18,000	18,000	18,000	26,000	26,000
Permitted gross combination weight		32,000/36,000 ²⁾	32,000/36,000 ²⁾	32,000/36,000 ²⁾	40,000	40,000

The Axor – model overview		3236	3240	3243
Engine (BlueTec® 5)	No. of cylinders	IL 6 ¹⁾	IL 6 ¹⁾	IL 6 ¹⁾
	kW (hp)	265 (360)	295 (401)	315 (428)
	Max. output (rpm)	1900	1900	1900
	Nm	1850	2000	2100
	Max. torque (rpm)	1100	1100	1100
Transmission	G211-16 (16 gears)	•	•	•
Cab	S extended	•	•	•
Wheelbase in mm	Tipper (K)	5100	5100	5100
	Concrete mixer (B)	5100	5100	5100
Permitted axle loads and weights in kg	Permitted front axle load	2x7500	2x7500	2x7500
	Permitted rear axle load	19,000 ³⁾	19,000 ³⁾	19,000 ³⁾
	Permitted gross vehicle weight	32,000	32,000	32,000
	Permitted gross combination weight	44,000	44,000	44,000

• Standard x Optional – Not available ¹⁾IL: in-line engine ²⁾With G131 or G211 transmission ³⁾Rear bogie total

The Axor – cab types

S-cab

Exterior width: 2490 mm
 Exterior length: 1650 mm
 Interior width: 2000 mm
 Interior height: 1510 mm

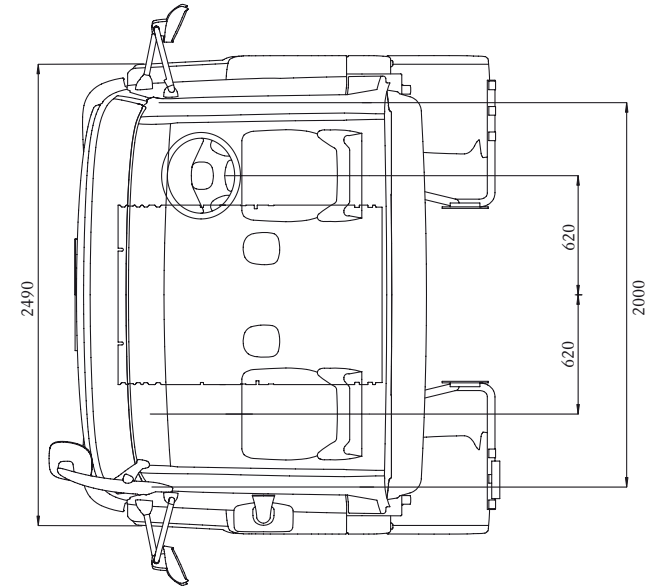
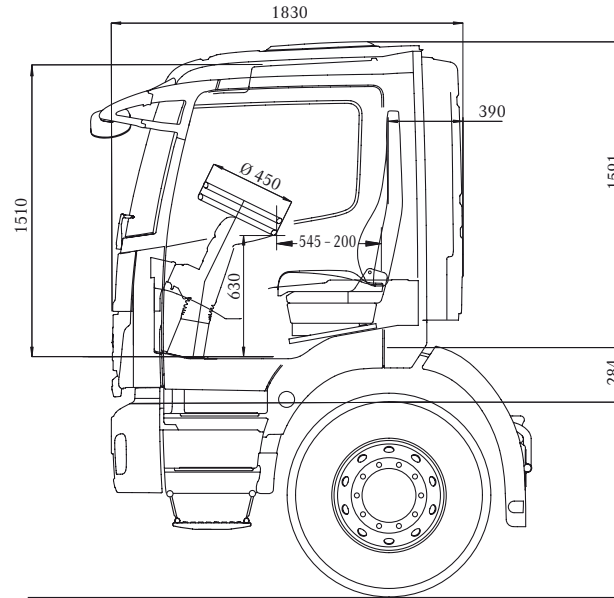

S-cab with extended rear panel

Exterior width: 2490 mm
 Exterior length: 1830 mm
 Interior width: 2000 mm
 Interior height: 1510 mm

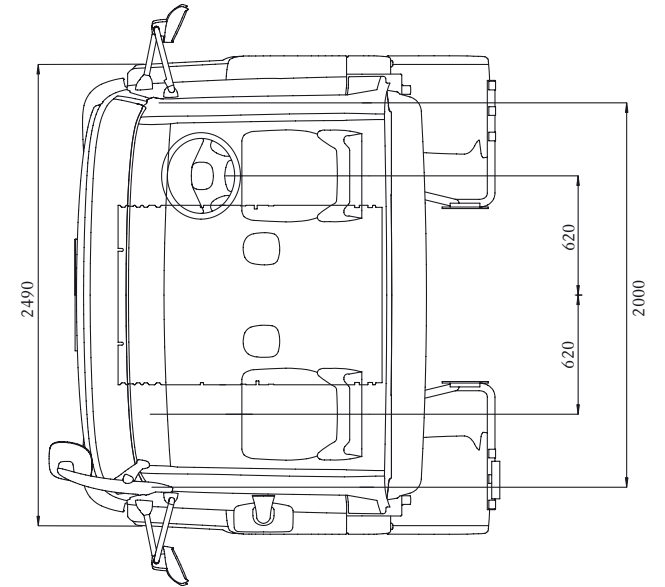
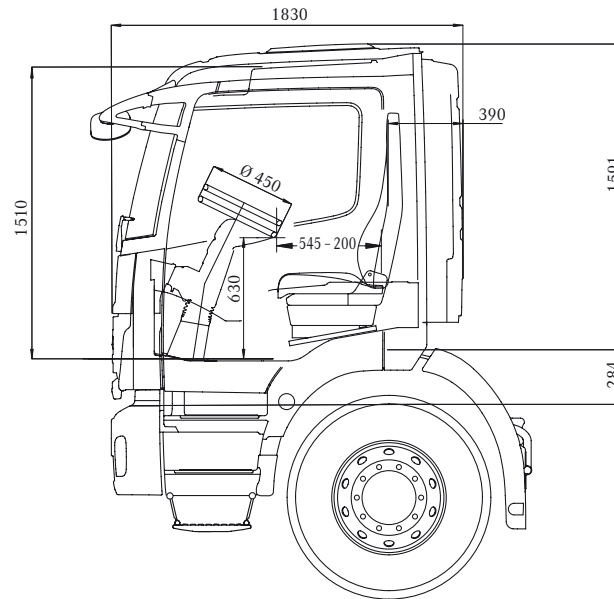

More than robust: the Actros

The Actros sets standards in heavy-duty construction site operation – with its robustness, off-road capability and its versatility. And with impressive reliability and cost-effectiveness.

Welcome to the Actros: from the pivoting entry step and the ergonomically designed instrument cluster to the optional rain and light sensor – the Actros shows how much the cab can contribute to helping master the demands made by work in heavy-duty operation. Just as useful: the battery status display and the one-touch indicator function.

With its frugal, reliable and powerful BlueTec® engines and its powertrain configurations perfectly tailored to the needs of the specific transport task, the Actros leaves nothing to be desired in terms of economic efficiency, either. Particularly long maintenance intervals and the Mercedes PowerShift offroad¹⁾ automatic transmission, optimised for operation on construction sites, contribute to further enhancing its economy. High levels of robustness are provided by the optionally available steel protective grilles for headlamps and tail lights and by protective stainless-steel plates for the radiator and engine, which are standard specification for tippers. In short: irrespective of whether it's a dropsider, a concrete mixer, or a tipper, and irrespective of whether it's a two, three, or four-axle truck – with the Actros you can successfully tackle every challenge in heavy-duty operation. We'll show you how!

¹⁾ Available as an option for 6x4/8x4 tippers and concrete mixers







For strenuous jobs. And relaxing breaks

The cabs for the Actros combine functionality and comfort in a unique way – through exemplary ergonomics and many practical details.

You might just want to stay on board. Whether you have chosen the S-cab, optimised for maximum body lengths, or the M- or L-cab. Because all the Actros cabs have one thing in common: they represent a finely-honed solution for the driver and the requirements of the specific application. Through practical equipment and many details: for instance the ergonomically designed instrument cluster, the standard-specification compressed-air connection on the driver's seat, the sunblind for the driver's side and the optional back-lit Mercedes star integrated in the front-end flap. You can see that the Actros is born to be on the construction site from tell-tale signs such as its scratch-resistant, ribbed exterior mirror housings¹⁾ and the 3 mm-thick stainless-steel protective plate for the radiator and engine. Further characteristic features include the corner panels which reduce air resistance and dirt build-up on the vehicle's sides.

¹⁾ Standard for tippers and concrete mixers

²⁾ Standard for tippers



The radiator and engine of the Actros²⁾ can be protected by means of a 3 mm-thick stainless-steel guard plate. This can prevent expensive damage, thus contributing to lower repair costs. On request, the main fuel tank can be equipped with a steel protective plate, too



The medium-length cab offers lots of space and freedom of movement; room for everything that needs to be within easy reach on the construction site. It can be fitted with a folding bed mounted on the cab rear panel, and a centre seat

Nothing forgotten, everything on board

It isn't always great sophisticated ideas that enhance ergonomics, comfort or safety. Sometimes it's the intelligent little details that help make our daily work easier: the Actros shows you how.

Great ride comfort: from the standard air-sprung suspension seat to the optional comfort air-sprung suspension seat – in conjunction with the infinitely adjustable multifunction steering wheel, all driver's seats make an optimum seat position possible. Thanks to the precise, direct steering and the user-friendly instrument cluster, work on board the Actros is especially easy. And the standard-fit one-touch indicator function means even more ride comfort: simply nudge the combination switch –

and the Actros indicates five times. Apart from this, the optional rain and light sensor noticeably assists the driver and improves safety even further. It automatically activates the wipers when it rains, and switches on the vehicle lights when dusk begins to fall. And the illuminated control panel for the Telligent® level control with a switch on the instrument panel, with which the Actros can be raised to the standard level at the touch of a button, also contributes to greater working comfort on

air-sprung vehicles. Another practical detail: the auxiliary brake and the standard-specification cruise and braking speed control functions are located on the steering-column lever on the right. Different interior lighting variants ensure the best possible lighting conditions for the job, for instance cockpit lighting with a bright reading light for early mornings or late evenings.



On tippers, concrete mixers and all-wheel-drive vehicles, the pivoting access step²⁾ is secured to the truck by rubber elements. If this step is struck by a boulder, or touches the ground, for example, it recoils in both a longitudinal and a transversal direction, thus providing protection against damage



The ribbed exterior mirror housings²⁾ on the Actros don't just look good – thanks to their robust surface they prevent damage, contributing to greater safety. On the construction site. And on the road



The analogue and digital displays in the instrument cluster adorned with chrome surrounds are clearly legible, thanks to a winning combination of lettering, colours and dials



The optional comfort air-sprung suspension seat with its multitude of adjustment options – including lumbar support and lateral contour adjustment – offers supreme comfort for driving. It is only surpassed by the optional ventilated comfort air-sprung suspension seat made of sturdy velour and Alcantara, which is able to dissipate seat heat and moisture



The sunblind³⁾ that reduces heat penetration into the cab and protects from the sun's glare is available for the driver's and co-driver's side. It is continuously adjustable to any position, allowing a free line of sight to the wide-angle mirrors and part of the exterior mirrors



Whether it's an S-, an M- or an L-cab, they all have this in common: thanks to ergonomically positioned controls and a practical stowage concept with the extended instrument support, the Actros cockpit provides an ideal work environment for virtually all demands and every kind of operation



Advantages at a glance

- **Application-based cab variants**
- **Premium-quality interior equipment**
- **3 mm-thick stainless-steel protective plate for the radiator/engine¹⁾**
- **Steel protective plate for the main tank optionally available**
- **Ribbed exterior mirror housing²⁾ for more robustness**
- **Optimised, longitudinally and transversely pivoting access step²⁾**
- **Optionally available back-lit Mercedes star**
- **Optional comfort air-sprung suspension seat on driver's and co-driver's side**
- **Improved instrument cluster with large matrix display**
- **One-touch indicator function**
- **Sunblind on driver's and co-driver's side³⁾**

¹⁾ Standard for tippers

²⁾ Standard for tippers and concrete mixers

³⁾ Standard for L-cab

More comfort, more fun on the job

The Actros makes wishes come true: with equipment that makes the job more pleasant, with exemplary comfort, a lot of room and individually selectable, practical extras.

Thanks to the pleasant working climate in the Actros you start to feel at home right away. In the S- and M-cabs a powerful air-controlled heating and ventilation system with a standard-fit construction-site air filter ensures ideal air distribution and pleasant temperatures. A manually regulated air conditioning system is available as an option. In addition an automatic climate control system and hot-air auxiliary heating can be provided optionally.

A particularly practical detail: the standard-specification compressed-air connection on the rear of the driver's seat can be used, for instance, for cleaning the cab. Also on board: stowage facilities and compartments on a large scale – for example the two outside stowage compartments of the L-cab which can also be accessed from the interior and are big enough to accommodate a drinks crate comfortably. Added to this, there are

further functional items of optional equipment that help to make the job on the construction site less arduous, for instance: radios with a Bluetooth hands-free system, a special Mercedes-Benz truck navigation system and a folding table on the co-driver's side.



In the M-cab, the stowage compartments behind the seats provide ample space for everything you need at the construction site. In the L-cab you can use the two spacious compartments located under the comfort bed. These compartments can also be accessed from the interior of the cab



The tool compartment behind the seats in the S-cab ensures order and tidiness, so that everything has its fixed place and is to hand when needed



A 25-litre refrigerator is optionally available for all cab models. It can keep your well-deserved snacks fresh and your drinks cool. Alternatively, stowage compartments of various sizes, or a third seat, can be installed on the engine tunnel



1.

1. The optionally available folding table on the co-driver's side helps make breaks or doing paperwork that much more pleasant. The table has a sturdy, washable surface and can be set up and folded away easily and rapidly



2.

2. The standard-specification compressed-air connection on the rear of the driver's seat comes in handy in conjunction with the air gun (standard equipment with a spiral hose for tippers, concrete mixers and all-wheel-drive vehicles) for instance for cleaning the cab



DIN-standard slots above the windscreen provide space for the digital tachograph, a permanently-installed telephone, a CB radio, FleetBoard®, and the optional radio with an integral Bluetooth hands-free system, CD player and an interface for an MP3 player as well as a CD changer



Optional: the truck navigation system from Mercedes-Benz is tailored to the needs of the construction industry. Among other things, it takes account of maximum headroom beneath underpasses, and weight limits which can influence the transportation of machines and materials



The door operating panel with the controls for mirror adjustment and heating, the switches for the power windows, the optional central locking system and the extended central locking system. The eyeball-type air outlets prevent misting-up of the side windows



Advantages at a glance

- Standard-specification compressed-air connection on the rear of the driver's seat
- A compatible compressed-air gun with a spiral hose is standard equipment for tippers, concrete mixers and all-wheel-drive trucks
- Optional folding table on co-driver's side that can be quickly set up and folded away
- Optional truck navigation system from Mercedes-Benz
- Numerous practical stowage trays and compartments
- Optional refrigerator with a capacity of 25 l
- Powerful, thermostatically controlled heating and ventilation system
- Optional hot-air auxiliary heating, optimised, temperature-controlled auxiliary air conditioning, air conditioning system¹⁾ or automatic climate control
- Illuminated switch console for power windows, mirror adjustment, mirror heating and central locking system
- Radios with Bluetooth hands-free system optionally available

¹⁾ Standard for L-cab



At last: a capital investment that lives up to your expectations

In terms of reliability and economic performance, too, the Actros once again sets standards and produces relaxed smiles all round. On the construction site. And in the controlling office.

Robust, application-specific technology that pays off – courtesy of the powerful, frugal BlueTec® engines. As an option there are also vehicle variants¹⁾ which meet the stringent EEV emissions standard²⁾. The standard-fit Telligent® maintenance system allows particularly long, individually computed maintenance intervals based not on mileage but on the actual status of all service products. Also optionally available and in every sense impressive: the 12-speed Mercedes PowerShift offroad³⁾ automatic transmission, with five specifically selectable programs and practical supplementary functions which make for improved vehicle handling and more driving comfort, together with lower fuel consumption. The battery status display and the dual-stage controlled water pump⁴⁾ also help to cut costs.

¹⁾ Actros with engine outputs from 235 to 335 kW (320 to 456 hp) and standard exhaust silencer

²⁾ Enhanced Environmentally Friendly Vehicle

³⁾ Available as an option for 6 x 4 / 8 x 4 tippers and concrete mixers

⁴⁾ In conjunction with V6 engines



The optional 12-speed Mercedes PowerShift offroad³⁾ automatic transmission was especially developed for heavy-duty construction work. Thanks to its shorter gearshift force interruptions, it protects the powertrain and ensures noticeably more dynamism and superior vehicle handling even on the most difficult terrain



The battery status display included as standard allows continuous monitoring of the battery charge and remaining starting ability, thereby avoiding unforeseen downtimes and the costs they incur

Top performer for heavy-duty operations

In order to enable the Actros to perform as you expect it to, we have equipped it with virtually everything that helps make heavy-duty operations easier: powerful V6 and V8 engines, application-based transmissions, gearshifts, axles and many other valuable technical details that prove their worth on every construction site.

The Actros impresses with nine powerful and durable BlueTec® engines. Five 16-speed transmissions with different ratios, together with application-based drive axles ensure that the power delivered by the engine reaches the wheels with as little loss as possible. The optional Telligent® gearshift has a special construction mode for construction industry vehicles, while the 12-speed Mercedes PowerShift offroad¹⁾ automatic transmission is available as an option for enhanced ride comfort and economy. Thanks to its optimised shift strategy, smooth gear changes and short gearshift force interruptions it is easy on the drive system and brings noticeably more dynamism in difficult terrain. Optimum handling is ensured by additional programs and functions. Four reverse gears, two of which are high-ratio, are advantageous for driving long stretches in reverse, and for access in places with insufficient space to turn round. As you can see, Mercedes PowerShift offroad has just about everything a driver or operator can expect from a gearshift.



With specifically selectable programs, for example power offroad mode, manoeuvring mode and rocking mode, as well as application-based additional functions such as the ability to shift directly from 1 to R, Mercedes PowerShift offroad²⁾ makes for more ride comfort, safety and economy



The standard-fit differential locks are operated by means of a rotary switch according to a simple logic: the differentials are locked in the following sequence: inter-axle lock, driven rear axles and, if present, the driven front axles



Whether you choose the V6 or V8 – all the BlueTec® engines in the Actros perform convincingly in every way in heavy-duty construction-site operations thanks to their high output and reliability, as well as their low consumption and low pollutant and particulate emissions. As an option the Actros is also available with engines which meet the stringent EEV emissions standard²⁾ (Enhanced Environmentally Friendly Vehicle)

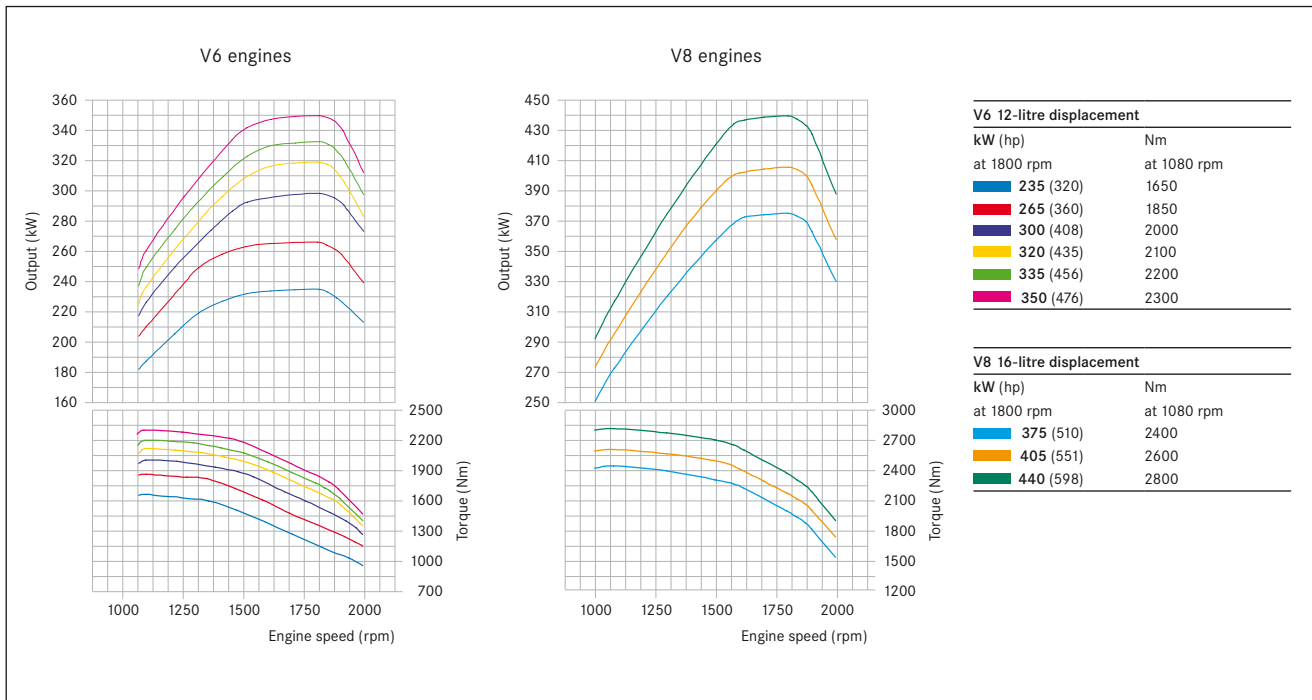

The output of the Actros engines ranges from 235 kW (320 hp) to 440 kW (598 hp). In all of these engines, the Telligent® engine system with an injection pressure of up to 2200 bar makes for particularly efficient, low-pollution combustion

i Advantages at a glance

- Mercedes PowerShift offroad¹⁾ automated transmission with 12 gears and specifically selectable programs and additional functions
- Reliable BlueTec® engines with low consumption
- As an option engines which meet the EEV emissions standard²⁾
- Telligent® engine system for high efficiency and low-pollution combustion
- Telligent® maintenance system for long, individual maintenance intervals
- Battery status display to avoid unforeseen downtimes
- Dual-stage controlled water pump for low consumption³⁾
- Standard differential lock and ASR for maximum traction

¹⁾ Available as an option for 6 x 4/8 x 4 tippers and concrete mixers

²⁾ Actros with engine outputs from 235 to 335 kW (320 to 456 hp) and standard exhaust silencer

³⁾ In conjunction with V6 engines



Going to the limit

Whether you're looking at the frame, axles or suspension, the Actros sets standards with its sturdy, durable design, both in terms of its load bearing ability and its reliable efficiency.

Standard equipment for the Actros includes steel suspension with parabolic springs fitted with maintenance-free rubber molecular bearings. The front axle has dual-leaf packets while the rear axle is fitted with 3-leaf or 4-leaf packets depending on the weight. Harder spring variants and reinforced stabilisers are available for the front and rear axles. And 3- and 4-axle trucks feature wishbone control arms for precise rear axle location.

For on-road vehicles working in the construction industry supply sector and which also need to ride unpaved tracks, an off-road apron is optionally available. Equipment includes a steel bumper without a front apron, the pivoting step and the front underride guard.



For arduous operating conditions: in order for the backbone of the Actros to be able to withstand even the most exacting loads placed on it, the frame is constructed with thicknesses of 7 mm, 8 mm, 9 mm or 9.5 mm with reinforcement depending on the vehicle model. The 50 mm hole matrix enables straightforward, cost-effective attachment of bodies, while the cathodic dip priming process provides the best possible corrosion protection. Other advantages include a frame end consisting of bolted components which are easy and inexpensive to replace if repairs are necessary



Axle load compensation between the front axles is a standard feature of all the 4-axle vehicles. Whenever the vehicle drives over an obstacle, the axle taking the most load transfers some of the load to the other axle – thus protecting the suspension mounting, steering system and tyres, as well as increasing ride comfort

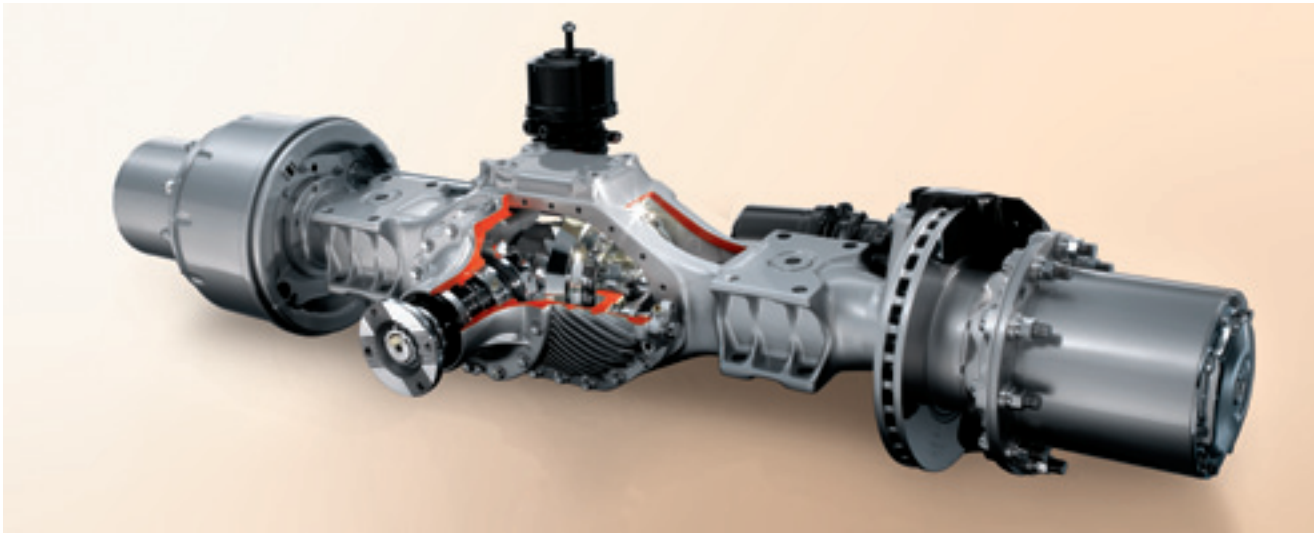

For maximum ground clearance, the Actros is available on request with the tried-and-tested and particularly robust HL 7 planetary axle. On the 3-axle and 4-axle vehicles the tandem unit also features the proven HD 7 through-drive axle – both designed for a maximum axle load of 16 tonnes where legislation permits

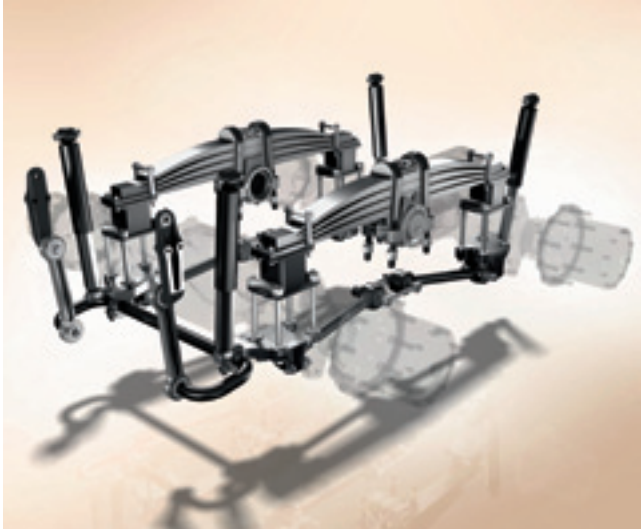

Steel-sprung Actros vehicles are equipped with weight-optimised parabolic springs as well as precisely-adjusted shock absorbers and stabilisers. A special zinc-rich paint protects the parabolic springs against corrosion, making the suspension system especially durable and robust



2-axle and 3-axle Actros vehicles can be optionally equipped with a stainless-steel exhaust tailpipe adjustable in direction and height. This helps avoid the need for conversions later on, and thus unnecessary costs



Advantages at a glance

- Weight-optimised, robust frame, ideal for mounting bodies, with a 50 mm hole matrix
- Robust, durable steel suspension with outstanding corrosion protection
- Axle load compensation for all 4-axle trucks as standard
- Four-bellows air suspension for chassis/cabs and air-sprung tippers
- Bodybuilder interface for swift, straightforward connection of body components to the vehicle's electrical system is available
- HL 7 planetary axle with maximum ground clearance available on request
- Optionally available for 2-axle and 3-axle trucks: exhaust tailpipe adjustable in direction and height behind the cab



The Actros – model overview	2-axle vehicle	1832	1836	1841	1844	1846	1848	1851	1855
Engine (BlueTec® 5)	No. of cylinders	V6	V6	V6	V6	V6	V6	V8	V8
	kW (hp)	235 (320)	265 (360)	300 (408)	320 (435)	335 (456)	350 (476)	375 (510)	405 (551)
	Max. output (rpm)	1800	1800	1800	1800	1800	1800	1800	1800
	Nm	1650	1850	2000	2100	2200	2300	2400	2600
	Max. torque (rpm)	1080	1080	1080	1080	1080	1080	1080	1080
Cab	Short (S)	x	x	x	x	x	x	x	x
	Medium (M)	x	x	x	x	x	x	x	x
	Long (L)	x	x	x	x	x	x	x	x
	Megaspace	-	-	-	-	-	-	-	-
Wheelbase in mm	Chassis/cab	4500	4500	4500	4500	4500	4500	4500	4500
		4800	4800	4800	4800	4800	4800	4800	4800
		5100	5100	5100	5100	5100	5100	5100	5100
		5400	5400	5400	5400	5400	5400	5400	5400
		5700	5700	5700	5700	5700	5700	5700	5700
		6000	6000	6000	6000	6000	6000	6000	6000
	Tipper	3600	3600	3600	3600	3600	3600	3600	-
		3900	3900	3900	3900	3900	3900	3900	
	Semitrailer tractor	3600	3600	3600	3600	3600	3600	3600	3600
		3900	3900	3900	3900	3900	3900	3900	3900

x Optional - Not available All-wheel-drive and extra-heavy-duty rigid, tipper and tractor models are available on request. Some combinations of equipment may not be available on certain models

The Actros – model overview	4-axle vehicle	3232	3236	3241	3244	3246	3248
Engine (BlueTec® 5)	No. of cylinders	V6	V6	V6	V6	V6	V6
	kW (hp)	235 (320)	265 (360)	300 (408)	320 (435)	335 (456)	350 (476)
	Max. output (rpm)	1800	1800	1800	1800	1800	1800
	Nm	1650	1850	2000	2100	2200	2300
	Max. torque (rpm)	1080	1080	1080	1080	1080	1080
Cab	Short (S)	x	x	x	x	x	x
	Medium (M)	x	x	x	x	x	x
	Long (L)	x	x	x	x	x	x
	Megaspace	-	-	-	-	-	-
Wheelbase in mm	Chassis/cab	-	-	8 x 4/4	8 x 4/4	8 x 4/4	8 x 4/4
				5400	5400	5400	5400
	Tipper	8 x 4/4	8 x 4/4	8 x 4/4	8 x 4/4	8 x 4/4	8 x 4/4
		5100	5100	5100	5100	5100	5100
	Concrete mixer	8 x 4/4	8 x 4/4	8 x 4/4	8 x 4/4	8 x 4/4	8 x 4/4
		5100	5100	5100	5100	5100	5100

The Actros – model overview	3-axle vehicle	2532	2536	2541	2544	2546
Engine (BlueTec® 5)	No. of cylinders	V6	V6	V6	V6	V6
	kW (hp)	235 (320)	265 (360)	300 (408)	320 (435)	335 (456)
	Max. output (rpm)	1800	1800	1800	1800	1800
	Nm	1650	1850	2000	2100	2200
	Max. torque (rpm)	1080	1080	1080	1080	1080
Cab	Short (S)	x	x	x	x	x
	Medium (M)	x	x	x	x	x
	Long (L)	x	x	x	x	x
	Megaspace	x	x	x	x	x
Wheelbase in mm	Air-sprung chassis/cab	6 x 2	6 x 2	6 x 2	6 x 2	6 x 2
		3900	3900	3900	3900	3900
		4200	4200	4200	4200	4200
		4500	4500	4500	4500	4500
		4800	4800	4800	4800	4800
		5100	5100	5100	5100	5100
		5400	5400	5400	5400	5400
		6000	6000	6000	6000	6000
	Air-sprung semitrailer tractor	6 x 2/2	6 x 2/2	6 x 2/2	6 x 2/2	6 x 2/2
		2550	2550	2550	2550	2550

x Optional – Not available

All-wheel-drive and extra-heavy-duty rigid, tipper and tractor models are available on request. Some combinations of equipment may not be available on certain models

The Actros – model overview	3-axle vehicle	2548	2551	2555	2560
Engine (BlueTec® 5)	No. of cylinders	V6	V8	V8	V8
	kW (hp)	350 (476)	375 (510)	405 (551)	440 (598)
	Max. output (rpm)	1800	1800	1800	1800
	Nm	2300	2400	2600	2800
	Max. torque (rpm)	1080	1080	1080	1080
Cab	Short (S)	x	x	x	x
	Medium (M)	x	x	x	x
	Long (L)	x	x	x	x
	Megaspace	x	x	x	x
Wheelbase in mm	Air-sprung chassis/cab	6 x 2	6 x 2	6 x 2	6 x 2
		3900	3900	3900	-
		4200	4200	4200	-
		4500	4500	4500	4500
		4800	4800	4800	
		5100	5100	5100	
		5400	5400	5400	
		6000			
	Air-sprung semitrailer tractor	6 x 2/2	6 x 2/2	6 x 2/2	-
		2550	2550	2550	

The Actros – model overview	3-axle vehicle	2632	2636	2641	2644	2646
Engine (BlueTec® 5)	No. of cylinders	V6	V6	V6	V6	V6
	kW (hp)	235 (320)	265 (360)	300 (408)	320 (435)	335 (456)
	Max. output (rpm)	1800	1800	1800	1800	1800
	Nm	1650	1850	2000	2100	2200
	Max. torque (rpm)	1080	1080	1080	1080	1080
Cab	Short (S)	x	x	x	x	x
	Medium (M)	x	x	x	x	x
	Long (L)	x	x	x	x	x
	Megaspace	-	-	-	-	x
Wheelbase in mm	Chassis/cab	6 x 4	6 x 4	6 x 4	6 x 4	6 x 4
		4200	4200	4200	4200	4200
		4500	4500	4500	4500	4500
		5100	5100	5100	5100	5100
	Tipper	6 x 4	6 x 4	6 x 4	6 x 4	6 x 4
		3300	3300	3300	3300	3300
		3600	3600	3600	3600	3600
		3900	3900	3900	3900	3900
	Concrete mixer	6 x 4	6 x 4	6 x 4	6 x 4	6 x 4
		3300	3300	3300	3300	3300
	Semitrailer tractor	-	-	6 x 4	6 x 4	6 x 4
				3300	3300	3300
	Air-sprung chassis/cab	6 x 4	6 x 4	6 x 4	6 x 4	6 x 4
		4200	4200	4200	4200	4200
		4500	4500	4500	4500	4500
		4800	4800	4800	4800 ²⁾	4800 ²⁾
	Air-sprung tipper	6 x 4	6 x 4	6 x 4	6 x 4	6 x 4
		3300	3300	3300 ²⁾	3300 ²⁾	3300
	Air-sprung semitrailer tractor	6 x 4	-	6 x 4	6 x 2 ¹⁾ /6 x 4	6 x 2 ¹⁾ /6 x 4
		-		3300	3300	3300

x Optional - Not available ¹⁾With twin-tyred trailing axle ²⁾Megaspace cab available

All-wheel-drive and extra-heavy-duty rigid, tipper and tractor models are available on request. Some combinations of equipment may not be available on certain models

The Actros – model overview	3-axle vehicle	2648	2651	2655	2660
Engine (BlueTec® 5)	No. of cylinders	V6	V8	V8	V8
	kW (hp)	350 (476)	375 (510)	405 (551)	440 (598)
	Max. output (rpm)	1800	1800	1800	1800
	Nm	2300	2400	2600	2800
	Max. torque (rpm)	1080	1080	1080	1080
Cab	Short (S)	x	x	x	x
	Medium (M)	x	x	x	x
	Long (L)	x	x	x	x
	Megaspace	x	-	x	x
Wheelbase in mm	Chassis/cab	6 x 4	6 x 4	6 x 4	-
		4200	-	-	
		4500	4500	4500 ²⁾	
		5100			
	Tipper	6 x 4	6 x 4	6 x 4	-
		3300	3300	3300	
		3600	-	-	
		3900	3900	3900	
	Concrete mixer	6 x 4	-	-	-
		3300			
	Semitrailer tractor	6 x 4	6 x 4	6 x 4	-
		3300	3300	3300	
	Air-sprung chassis/cab	6 x 4	6 x 4	6 x 4	6 x 4
		4200	-	-	-
		4500	4500	4500 ²⁾	4500
		4800 ²⁾	4800		
	Air-sprung tipper	6 x 4	6 x 4	6 x 4	-
		3300	3300	3300	
	Air-sprung semitrailer tractor	6 x 2 ¹⁾ /6 x 4	6 x 4	6 x 4	6 x 4
		3300	3300 ²⁾	3300 ²⁾	3300 ²⁾

The Actros - cab types

S-cab

Exterior width: 2500 mm
 Exterior length: 1700 mm
 Interior width: 2260 mm
 Interior height: 1560 mm

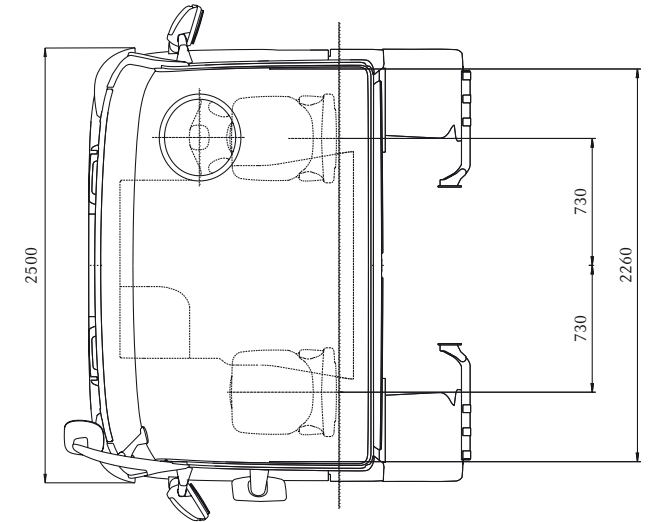
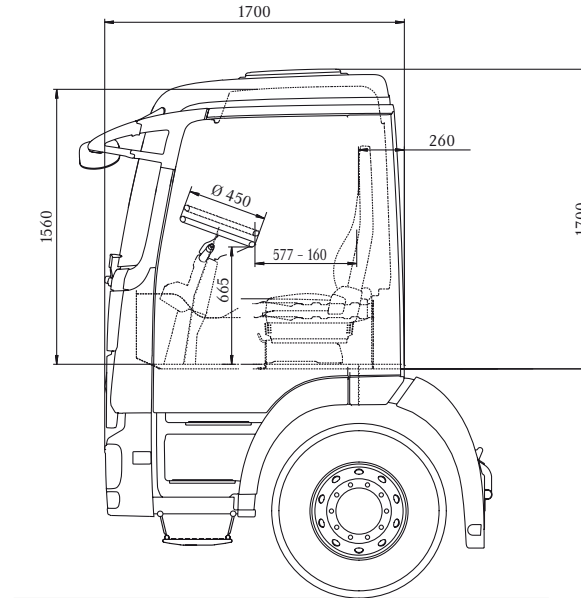

M-cab

Exterior width: 2500 mm
 Exterior length: 1950 mm
 Interior width: 2260 mm
 Interior height: 1560 mm

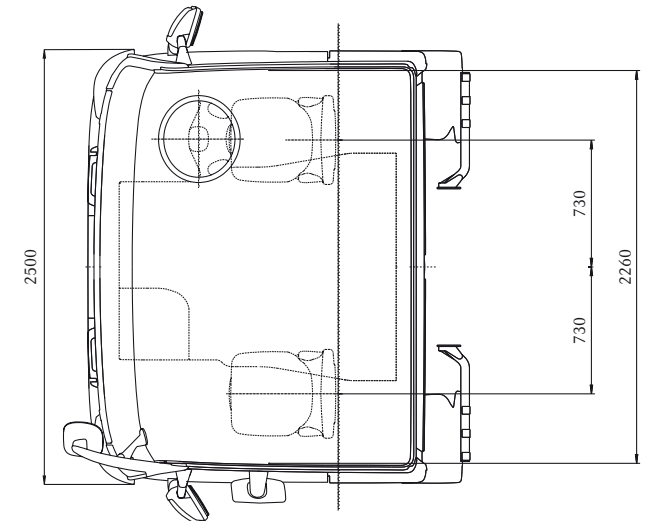
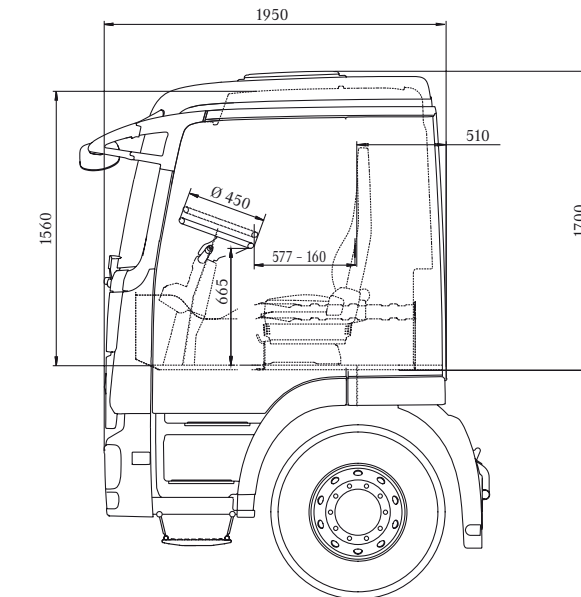

M-cab
(with a low roof)

Exterior width: 2500 mm
 Exterior length: 1950 mm
 Interior width: 2260 mm
 Interior height: 1400 mm

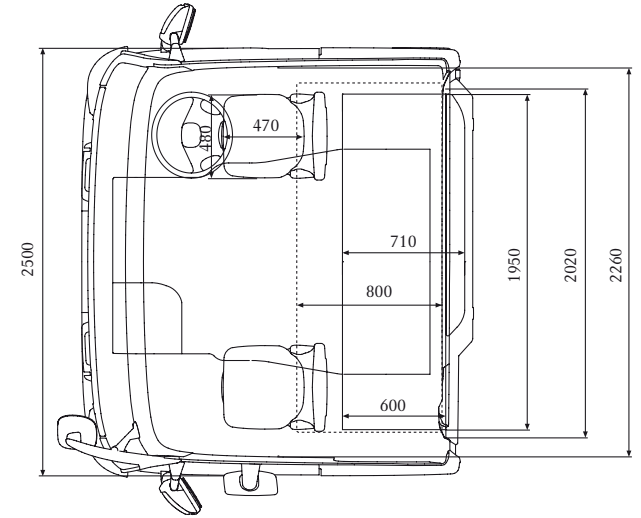
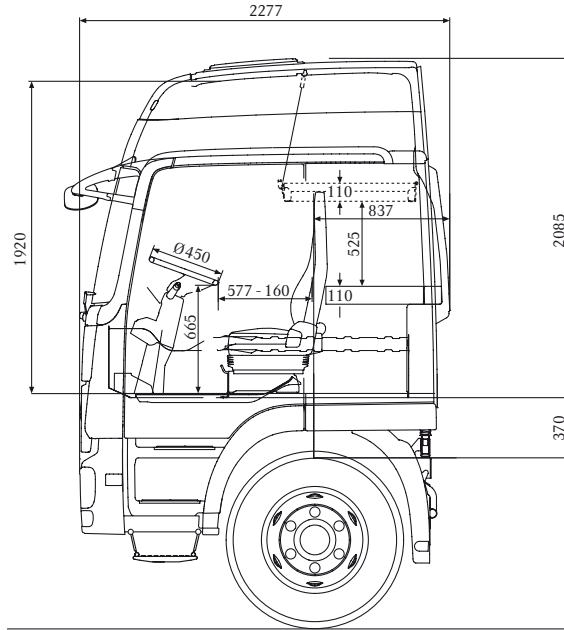

L-cab	with a low roof	with Single cab
Exterior width:	2500 mm	2500 mm
Exterior length:	2277 mm	2277 mm
Interior width:	2260 mm	2260 mm
Interior height:	1560 mm	1920 mm

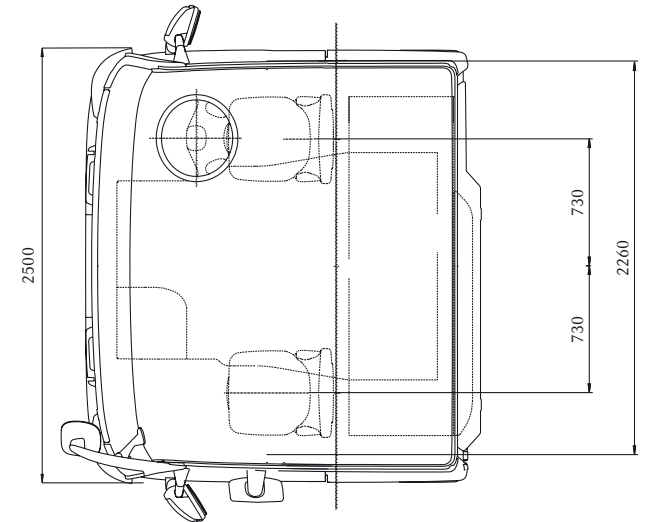
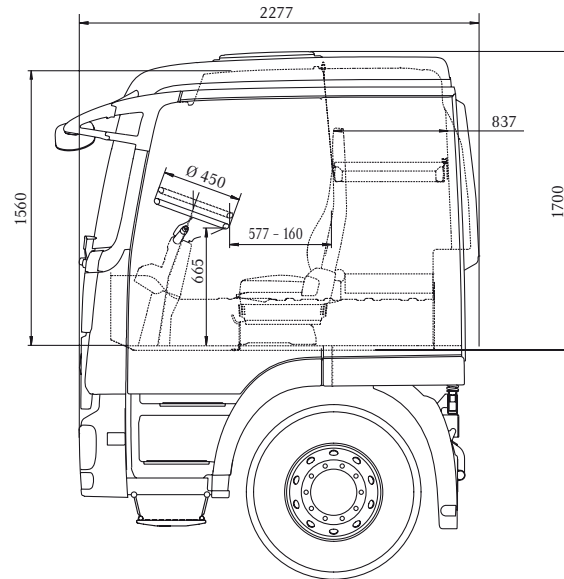



Plenty of safety. On the road, and off

Avoiding accidents is of paramount importance. And we will go to any lengths to do so. On paved roads and off, enhancing both active and passive safety. See for yourself!

A safe, convenient entrance with grab handles on either side is just as much a part of the safety equipment for the Atego, the Axor and the Actros as the non-splintering, flame-retardant materials used in the vehicle interior. Safety can be given an increased boost by opting for the driver's airbag with a belt tensioner. A generously-sized windscreen and deep side windows, together with the mirror system which includes a front mirror and optimally placed wide-angle mirrors, afford a good all-round view. The front underride guard and the spray protection on the wings contribute to the safety of other road users, for example, by minimising the spray mist caused when driving on wet road surfaces. To our mind, safety also includes protecting the vehicle and driver from uninvited guests – which is why an extended central locking system and an anti-theft warning system are available on request.



Steel protective grilles are available upon request for the headlamps and the tail lights of the Actros. They prevent damage by stone chippings, gravel or other bulk material, thus contributing to reducing repair costs and increasing safety. These protective grilles are also optionally available for the Atego and the Axor

It's safe to say we're one step ahead

Nowadays it is by no means enough simply to have a good brake system. That's why the Atego, the Axor and the Actros are optimally prepared should the worst ever come to the worst: with an especially short braking distance. And with many other details that enhance safety even further.

Safety has right of way. That's why the Atego, the Axor and the Actros are all equipped with a powerful brake system with internally ventilated disc brakes, ABS, ASR and a constant operating pressure of 10 bar. For even shorter braking distances, the Telligent® braking system¹⁾ is available. The integral Brake Assist function reacts swiftly in hazardous situations and makes the full braking effect available instantaneously. In addition – except

during a full brake application – the non-wearing brakes are also included in every braking manoeuvre. And the integral hill-holder²⁾ prevents the vehicle from rolling forwards or backwards when moving off.

The clear-lens headlamps fitted as standard on our trucks afford excellent night-time visibility, thus enhancing safety. Even better road illumination and an even stronger light is provided by the optional xenon or bi-xenon

headlamps (depending on the vehicle and equipment). A headlamp cleaning system, available on request, further improves vision and safety.

¹⁾ Available as special equipment for the Atego and Axor

²⁾ Standard for the Atego and Axor and the Actros in conjunction with the Telligent® braking system



To ensure that the brake discs fitted on our trucks offer optimum safety when it really matters, they must perform flawlessly when subjected to the extreme loads experienced on the rotating-mass friction test station, for example. The result: even under high strain, the braking effect is virtually unchanged



The radiator and engine of the Actros³⁾ can be protected by means of a 3 mm-thick stainless-steel guard plate. This can prevent expensive damage, thus contributing to lower repair costs. On request, the main fuel tank can be equipped with a steel protective plate, too



The rain and light sensor, available as an option for the Actros, enhances safety and comfort by automatically turning on the windscreen wipers when it starts to rain. It also turns on the headlamps, for instance when the vehicle enters a tunnel





The Telligent® braking system¹⁾ ensures extremely short stopping distances, and can be enhanced by incorporating deactivatable ABS. This makes it possible to cause the wheels to lock intentionally when braking, should the situation make it necessary, e.g. in heavy-duty off-road operation



The hill-holder function²⁾, integrated in the Telligent® braking system¹⁾ increases both ride comfort and safety. It prevents the vehicle from inadvertently rolling forwards or backwards, making child's play of pulling away on an incline



Less dirt build-up on the sides of the vehicle and improved aerodynamics – the carefully-designed shape of the corner panels fulfils the highest standards in terms of comfort, safety and economy



Atego, Axor and Actros – all three model series are equipped as standard with mirror heating which can be switched on and off manually. This rapidly clears mirrors from condensation or ice, aiding optimum all-round visibility in virtually all situations



Advantages at a glance

- Powerful brake system for short stopping distances; equipped with Brake Assist and hill-holder²⁾ depending on the vehicle
- Deactivatable ABS
- 3 mm-thick stainless-steel protective plate for radiator/engine is standard for tippers⁴⁾
- Steel protective plate for the main tank optionally available⁴⁾
- Optionally available rain and light sensor⁴⁾ for greater ride comfort and safety
- Generously sized window areas, good all-round view and mirrors with manual heating control
- Interior with non-splintering, flame-retardant materials
- Xenon or bi-xenon headlamps⁵⁾ for better road illumination and improved safety

³⁾ Standard for tippers

⁴⁾ Only for the Actros

⁵⁾ Availability depends on vehicle version



Reliability is a must, not a bonus

When it comes to quality there is no such thing as compromise. Which is why we test our trucks for longer, under tougher conditions, and over and over again. To produce durable vehicles which can do their job safely and reliably. Day in and day out.

Quality is a matter of standards on the one hand and demands on the other. So that we are able to live up to your expectations in this regard, we leave absolutely nothing to chance when it comes to quality and reliability. From the design phase with state-of-the-art CAD technology and digital mock-ups and virtual, computer-simulated tests to an extremely thorough and exhaustive programme of practical testing - each and every component must prove its suitability for everyday use several times over. And keep proving it at regular intervals afterwards. This continuous quality process also draws on the experiences of our customers and of our service outlets. For it is only the desire to keep bettering which enables the Atego, the Axor and the Actros to attain the hallmark of quality and perform their job reliably under the most rigorous conditions. On the construction site. And on the way there.



Before our trucks are allowed onto the construction site they are subjected to a rigorous test routine. Apart from robustness and reliability, they are also tested in terms of their aerodynamics. Because only a truck that achieves first-class results here can offer you the basis for economical operation

We test our trucks long and hard

Each of our trucks is developed, built and tested with day-to-day use in mind, for only a truck which can fulfil the demands of practical operation can fulfil our expectations ... and yours too.

A vehicle's quality is determined back in the development phase. CAD technology and the computer simulations make it possible to test the reliability of every single component and of the truck as a whole, long before the first prototype is ready. With a view to improving ease of maintenance and repair, computer-generated digital mock-ups are used to determine whether a part can be replaced easily or not.

And even once a vehicle has successfully passed our tough practical tests – ranging from the many different test station runs to summer and winter testing – it still has to overcome one final, all important test: the customer driving trials. For nothing can uncover hidden weaknesses as ruthlessly as the daily routine. By conducting regular technical checks of the vehicles, as well as quizzing the drivers and firms, we have a chance to react to the

experiences gained during day-to-day use, and incorporate them into the vehicle design before series production starts up. So that our trucks can live up to your expectations when operating in the construction industry.



The strains of weathering in fast motion: the dynamic corrosion test subjects the trucks to extreme climatic conditions during several months of cycles in the salt spray chamber and the climate chamber. To inspect the quality of the overall vehicle's corrosion protection, it is also put through its paces by an alternating cycle of long-distance driving programmes on rough roads, motorways, gravel and dirt tracks



On the servo-hydraulic test station, uneven road surfaces encountered when driving on motorways, on country roads or over speed bumps are simulated with outstanding reproducibility. The aim of the tests is to improve the vibration characteristics of axles, frames and detachable parts, thus reducing the dynamics of the components, increasing ride comfort and promoting smooth transport of the cargo



The engines of our construction vehicles are required to pass test station endurance trials that equate to a mileage running into millions. For only an engine that is able to operate reliably for this long is optimally prepared for the real world



The propshaft test station once again examines the strains that act on the drive system before it is allowed to enter service in construction transport. Test-station runs with up to 58 different engine-speed, torque and operating-angle combinations reflect the usage profile. So that even the tiniest signs of damage and cracks can be detected, the articulated joints are subjected to laboratory analysis. This is the only way of ensuring that they have survived this endurance test unscathed, and are therefore up to the tough demands of construction transport



Advantages at a glance

- Continuous further development of all vehicle components
- Extremely robust components with optimum corrosion protection
- Reliable and durable engines
- Optimised aerodynamics and aeroacoustics
- Regular quality tests on test stations and in practical trials
- Comfortable, ergonomically designed cabs
- Cost-effective vehicle operation



Building trucks does not mean having only trucks in mind

Low fuel consumption and low exhaust emissions are not only the result of innovative, advanced technology. They are also the result of an attitude that is gradually translating our commitment to more environmental protection into reality in both our products and in production.

Thanks to BlueTec®, not only are the Atego, the Axor and the Actros amongst today's most economical trucks in construction transport, they are also some of the most environmentally responsible. And to ensure that this remains the case in the future, we are currently already working on solutions that bring yet more efficiency where the drive system is concerned – and also through a lower rolling and wind resistance.

But it is not only environmentally responsible powertrain systems that are important to us. The development of future-oriented trucks begins with the selection of suitable raw materials and continues with recycling-compatible design and environmentally friendly production methods that conserve resources. Additional measures such as BlueTecEco plus the continuous further development of our driver assistance systems, the use of FleetBoard® and the Mercedes-Benz driver training programmes actively contribute to environmental protection.



Mercedes-Benz Trucks has devised BlueTecEco – a package consisting of all the measures which make a significant contribution towards making transport more cost-effective and environmentally compatible. In short: BlueTecEco stands for efficient, fuel-saving vehicle technology and an extensive programme of advice, training and seminars



When designing our trucks, particular attention is paid to the reusability of the materials employed and a recycling-compatible design right from the start. As a result, around 85% of all the materials used in the Atego, Axor and Actros can be recovered

Environmental protection is a matter close to our hearts. Accordingly the measures taken for the environmentally compatible production of our trucks encompass the entire production process: saving primary energy and reducing CO₂ emissions by heat recovery plays a major part in this, as does the use of water-soluble paints which significantly contributes to the reduction in solvent emissions. Other examples include the reduction of waste water, the avoidance of waste and uncompromising recycling, which all contribute to a positive eco-balance – now and in the future.



BlueTec® technology provides further proof that environmental compatibility and cost-effectiveness are not mutually exclusive: a low level of CO₂ emissions, particularly low particulate emissions and lower fuel consumption impressively demonstrate this



Environment-oriented research – in addition to the development of alternative drive systems for the future, our driver assistance systems and FleetBoard® are being continuously improved – for here, too the potentials for greater fuel economy and lower emissions have not yet been fully realised



The Wörth plant, where the Actros, the Axor and the Atego are manufactured, operates an environmental management system, which is regularly scrutinised by independent environmental auditors and not only complies with, but exceeds, the requirements of the EMAS and ISO 14001 environment standards



Advantages at a glance

- Environmentally conscious research and development
- Conservation of resources through environmentally compatible production
- Advanced engine technology for low fuel consumption and low exhaust emissions
- BlueTec® for cost-effective compliance with Euro 5
- BlueTecEco for more cost-effective and environmentally-compatible transport
- Recycling-compatible design: up to 85% reusability
- Environmental management system at the Wörth plant
- Compliance with environmental standards EMAS and ISO 14001



We help you on your way

To make sure things keep running smoothly, we are there for you day and night, with our pan-European service network and extensive after sales service portfolio – both of which are tailored to fit your needs.

We're there for you. There to provide exactly the services you need, exactly when you need them. Which is why you will find more than 1750 service outlets spread throughout Europe, many of which stay open until 10 p.m. or midnight and some of which are even open around the clock. Should it be necessary, you can count on the assistance of our Mercedes-Benz Service24h day and night. Mercedes-Benz Financial Services are able to attend to all your finance and leasing needs. Meanwhile, the cost transparency and flexibility of your fleet can be further improved by opting for FleetBoard®. And besides all this, there are the thousands of Mercedes-Benz employees who speak your language and will do everything they can to help.



When you decide in favour of an Atego, Axor or Actros, not only have you opted for an outstandingly reliable truck; your vehicle comes complete with a service network on which you can rely at all times

We strive to make you happy

From workshop service to services such as FleetBoard®, CharterWay or financial solutions – we’re always there for you. Without any “ifs” and “buts”.

Workshop service – examples of what we take this to mean include extended opening hours, short repair times and efficient parts logistics. In other words, if your truck needs to visit one of our service outlets, it will only be there for as long as absolutely necessary. Our highly trained personnel will make sure of that, as will no less than 13 European logistics centres.

Breakdown service – whatever the time of day or night, a phone call to our Europe-wide freephone service hotline on 00800 5 777 7777/+44 (0)207 660 9992¹⁾ is enough to summon immediate assistance. With a selection of key parts and the STAR diagnosis unit on board, the Mercedes-Benz Service24h employees will set out immediately to bring you the assistance you need. They are

able to remedy some 80% of all breakdowns right there and then. The most important thing is to get your truck up and running again as quickly as possible. As a specialist for leasing, financing and insurance matters, Mercedes-Benz Financial Services is able to offer you specifically tailored financial products on attractive terms. Please contact your authorised Mercedes-Benz dealer for more information.



Long workshop opening hours: there are over 1750 Mercedes-Benz workshops throughout Europe, with some 400 of them staying open until 10 p.m., an increasing number until midnight, and some are even open around the clock. This means that even major repairs can be carried out within a single working day. To make sure that your truck is back on the road as soon as possible

¹⁾ The cost of mobile calls varies depending on the service provider



FleetBoard® stands for greater cost-effectiveness thanks to modern fleet and transport management. This is because FleetBoard® allows a continuous exchange of information between the driver, vehicle and fleet headquarters, which means that assignments can be better coordinated and capacities utilised more efficiently. It is also possible to calculate the time until the next service is due, and carry out an operating analysis. For more flexibility and lower costs: www.fleetboard.com



Mercedes-Benz DriverTraining shows even seasoned truckers how they can harness the potential of our trucks to even better effect. The Eco Driver Training programme results in a reduction in consumption of up to 10%, while driver safety training teaches techniques for masterfully bringing hazardous situations under control. Find out more about this and our CPC DriverTraining programme by visiting www.mercedes-benzdrivertraining.co.uk



Mercedes-Benz Financial Services offers you tailor-made solutions. With Contract Hire you get the benefit of being able to predict precisely what your costs will be, with the reassurance of being supported by the Mercedes-Benz dealer network. For more information about finance and leasing from Mercedes-Benz Financial Services, visit www.mbtrucks.co.uk/finance



Advantages at a glance

- Extensive workshop network with over 1750 service outlets throughout Europe
- Long workshop opening hours, with some open until 10 p.m. or midnight and some even open around the clock
- High level of parts availability thanks to thirteen European logistics centres
- Mercedes-Benz Service 24h – with freephone service hotline throughout Europe on 00800 5 777 7777/+44 (0)207 660 9992¹⁾
- Extensive portfolio of services for greater cost-effectiveness, e.g. FleetBoard®, Mercedes-Benz Financial Services and Mercedes-Benz DriverTraining



Go ahead, treat yourself

Motivating, practical, convenient – Mercedes-Benz genuine accessories offer the most varied possibilities for decorating and equipping your Atego, Axor or Actros workplace according to your personal taste – have fun!

Working on the construction site is tough. That's why a little extra creature comfort here and there can certainly do no harm. From the 23-litre coolbox with interior lighting and a removable wire basket to the large stowage tray which can simply be clipped onto the instrument support, and from the seat covers in a standard design to the steam-jet-cleaner-resistant natural rubber floor mats – everything contributes towards making work in the construction industry more pleasant.

In addition our comprehensive Mercedes-Benz genuine accessories range offers many other suggestions as to how you can equip the Atego, the Axor and the Actros optimally according to your individual requirements and wishes. For more information, please refer to our current accessories brochures or ask your authorised Mercedes-Benz dealer.



Safety has right of way: the front camera system allows you to see into the blind spot just in front of and to the side of the cab, thus improving safety when driving off and manoeuvring, and can in fact replace the front mirror. The front camera system is switched on and off automatically depending on the vehicle speed, and ensures glare-free, undistorted image reproduction on the monitor. Thanks to a built-in heating module it can be used all year round. A reversing camera system is also available. It is activated automatically when reverse gear is engaged, and makes the area immediately behind the vehicle visible. This is extremely useful, for example, when manoeuvring, as it enhances safety and prevents accidents. Its modular installation concept makes it possible to use a combination of front and reversing cameras





The extra stowage tray for the instrument support puts an end to fumbling around for those all-important items that should always be kept to hand, such as sunglasses, maps or a note pad and pens



The side window wind deflector provides ideal protection from draughts and rain. The side window can be opened a little at any time, allowing a pleasant continuous exchange of air. Especially useful in rainy weather, it prevents dangerous misting-over of the windows



The mobile phone cradles are suitable for Nokia 6233/6234, Nokia 6300 and Nokia 6303 Classic. The cradle is simply clipped on to the base plate. A further advantage: if you change mobile phones, only the cradle need be exchanged



Neat and tidy for better vision – the spectacles case. With a large opening for ease of reach. Attached to the A-pillar by means of an adhesive or Velcro strip



Advantages at a glance

- Reversing camera and front camera for more safety and improved accident prevention
- Side window wind deflector for protection from draughts and rain
- Practical additional stowage tray for instrument support
- Mobile phone cradle for Nokia 6233/6234, Nokia 6300 and Nokia 6303 Classic
- Tested Mercedes-Benz quality
- Adaptation to personal needs and preferences
- Individual configuration of interior and exterior

