

G-Class



Mercedes-Benz





First impressions

Please take a seat. Or, perhaps better, climb into a car that has everything you'd expect of a Mercedes-Benz: dynamic performance, comfort, safety and status. The G-Class continues to modernise, featuring the latest technical advances and innovations, yet it's firmly rooted in a great off-road tradition. That's true for the classic design, robust construction and, of course,

a penchant for extreme terrain. The G-Class is the only Mercedes that feels equally at home on the road as off it. A reliable teammate for any adventure, on glamorous boulevards or mountain ridges. Proof that being down-to-earth can make you feel on top of the world.

[Overview](#) | [from page 4](#) [Insights](#) | [from page 10](#)

Featured models:

G 63 AMG | *designo* Magno Platinum | front cover and page 2
AMG 5-twin-spoke alloy wheels, *designo* leather in Sand, AMG carbon-fibre trim

G 350 BlueTEC | Magnetite Black | page 28
5-twin-spoke alloy wheels, *designo* leather in Porcelain, *designo* Black Piano Lacquer wood trim

Specifications shown may include optional equipment and accessories



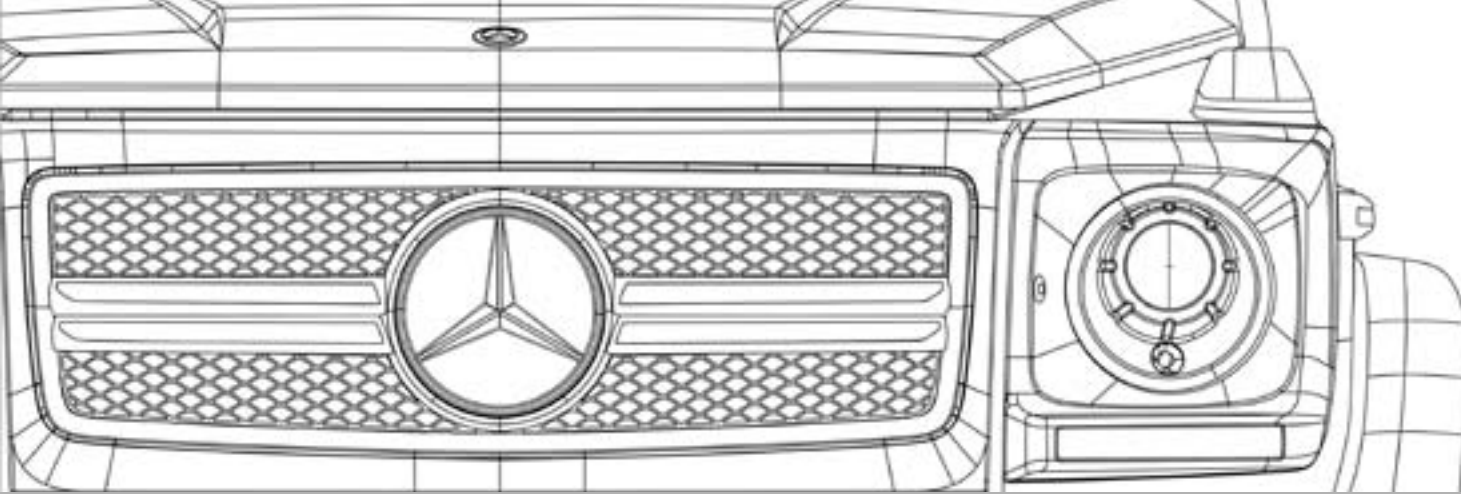

Facts

Luxuriously sporty on any terrain: powerful engines with transmissions to match, rigid axles, ladder frame, permanent four-wheel drive, off-road ratio, and three fully locking differentials pave the way for the G-Class – even when you’re miles away from tarmac.

Engines and suspension | from page 14

High demands – utmost safety: on top of its robust nature, the G-Class’ integrated safety concept adds to the high sense of protection. It features ESP® including Trailer Stability Assist, Distronic Plus, Blind Spot Assist, LED daytime running lights, Neck-Pro comfort head restraints as well as airbags.

Safety | from page 26

The wheels for any terrain: G-Class station wagon, as well as G 63 AMG.

G-Class design and AMG | from page 28

Five-star interior: multimedia assistants offer entertainment for all passengers, help you park and navigate.

Comfort | from page 32

As individual as the routes you choose: standard and optional equipment for the G-Class, including packages, *designo* and alloy wheels.

Equipment | from page 34

Star customer service: test drive, Mercedes-Benz Finance and Insurance, Interactive Owner’s Manual, Roadside Assistance and Mercedes-Benz World.

Services | from page 52

A strong eye for detail: dimensions, paint finishes and technical data.

Facts and finishes | from page 54





Making its own way – a path the G-Class will never divert from

Changing without changing. Building a new G-Class that stays true to its heritage, that's a great challenge. The result is a legend continued.



All-terrain is not an ability – it's an attitude

Unique challenges require special solutions: engines with the volume and performance to suit the special demands of an all-terrain vehicle, and 100% differential locks to help the G-Class adapt to nearly any kind of road and driving condition. → pages 14–17, 22–23



Also designed for the Hollywood Hills

Whether you're cruising down Bel Air or tackling the Mojave desert, the G-Class happily swaps the red carpet for red sand. It's designed for extremes, effortlessly mastering spontaneous changes of scenery. So wherever your imagination takes you, the G-Class is with you all the way.





Some cars have long memories. They remember the days before tarmac

Climb, wade, scramble, plough, drift – you wouldn't normally expect a car to perform these activities. Unless it's a G-Class. This Mercedes welcomes any challenge. It's always behind you, even when everyone else seems to have deserted. → pages 18–25



At home where even
dreams don't reach



The perfect space for the upper echelons

If you're reaching for the top, get on board the G-Class and you're half way there. The higher seating position, the ergonomic seat design and first-class comfort all make you feel like a king – whether you're on the road or off, on the way to a mountain top or to an economic summit. → page 33



[ge'lændevaxgn]

Nothing conjures up images like the term 'Geländewagen', the German word for cross-country vehicle. The mind instantly creates its very own motion picture, taking you through deserts, up steep mountain passages, surveying vast terrains yet to be explored. Your eyes are dry with sand, your skin parched by the sun, your whole body exhausted

by the strenuous journey, yet the G-Class remains unfazed, confidently mastering each task and obstacle you present it with. Wherever your imagination takes you, the main protagonist stays the same. Because if you think Geländewagen, there's nothing like the Mercedes-Benz G-Class. Don't just think off-road, think off-the-norm...



The stuff that legends are made of

Deutschmann nods. This slow, carefully considered movement marks his approval and perhaps the most important nod in the Grazer mountain region.

A few members of his team have observed him, only to quickly return their gaze to their work. Up to 45,985 stitches, countless cuts and folds require full concentration and absolute precision. And, finally, that scrutinising gaze. For 33 years, Herr Deutschmann has been casting his eyes over every G-Class. When he nods, it means “excellent work.” If he doesn’t, the results won’t ever see the light of the picturesque Austrian mountain day.

Up to 810 metres of yarn spin around the G-Class, holding together the body and soul of this mountaineering expert. There are no superfluous loops, not a stitch a millimetre out – proof of pure passion at work. To spur on the master craftsmen, pin-ups adorn the studio – not with images of scantily clad ladies, but with the full-bodied G-Class. A Mercedes through and through.



14 BlueTEC diesel engine**16 AMG V8 petrol engine****18 Transmissions**

7G-Tronic Plus

AMG Speedshift Plus 7G-Tronic

ECO start/stop function

20 Suspension

Ladder-type frame

Steering

Rigid-axle suspension

22 On- and off-road technology

Permanent four-wheel drive with 4ETS

Locking differentials

Off-road ratio

Unique G-Class attributes

26 Integrated safety concept

ESP® with Trailer Stability Assist

LED daytime running lights

Neck-Pro comfort head restraints

Airbags and windowbags

Distronic Plus

Blind Spot Assist

28 G-Class design**30 G 63 AMG****32 Multimedia systems**

COMAND Online system

Harman Kardon® Logic 7®

surround sound system

Rear seat entertainment system

**33 Parking assistants and
Seat Comfort Package**

Reversing camera

Parktronic

Seat Comfort Package



34 **Standard equipment**

35 **Optional extras**

36 **Chrome Package**

37 **Exterior Styling Package**

38 **Sports Package**

40 **Exclusive Package**

41 *designo* **Exclusive Package**

42 **Upholstery and trim**

46 *designo*

51 **Alloy wheels**

52 **Services**

Test drive

Mercedes-Benz Finance and Insurance

Interactive Owner's Manual

Roadside Assistance

Mercedes-Benz World and Museum

54 **Dimensions**

55 **Facts and finishes**

56 **Paint finishes**



BlueTEC diesel engine

With its impressive levels of low-range torque, the G 350 BlueTEC's diesel V6 engine gives you the pulling power you need when tackling tough terrain.

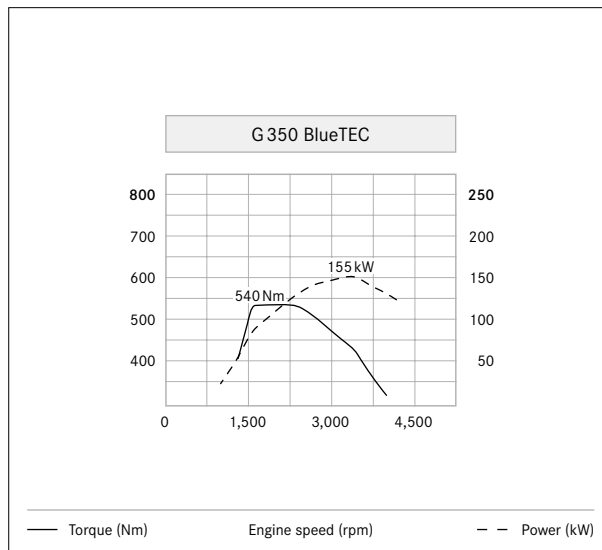

The maximum 540 Nm of torque is available from just 1,600 to 2,400 rpm

The G 350 BlueTEC's V6 common-rail diesel engine delivers 211 hp (155 kW) combined with excellent fuel efficiency, while the combination of precise piezo injectors, injection pressures of up to 1,600 bar, and an optimised turbocharger help it to generate an impressive 540 Nm of torque. What's more, the G 350 BlueTEC features a state-of-the-art catalytic converter system and uses the urea-based additive AdBlue® to clean and treat exhaust emissions, helping to reduce nitrous oxide emissions by up to 80%. A warning will appear in the instrument panel if the car is running low on AdBlue®, which can then be topped up in the same way as fuel. ISO 22241-compliant AdBlue® refill canisters are available from your Mercedes-Benz Retailer.



The G350 BlueTEC's diesel V6 engine offers effortless pulling power in all situations, combined with excellent fuel efficiency and low emissions



AMG V8 petrol engine

The new AMG biturbo V8 engine gives the G 63 AMG exhilarating on-road performance to go with its exceptional off-road ability.

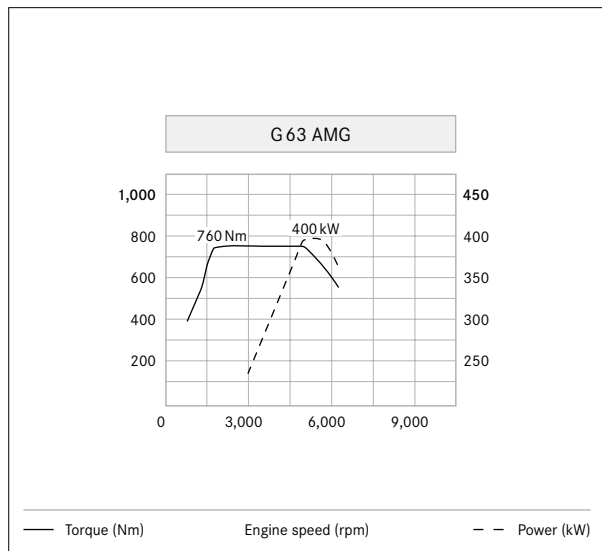

The G 63 AMG offers a mighty 760 Nm of torque all the way from 2,000 to 4,500 rpm

With its free-revving AMG 5.5-litre biturbo V8 delivering 544 hp (400 kW) plus a maximum 760 Nm of torque, the G 63 AMG offers class-leading on-road performance. It sprints from 0 to 62 mph in just 5.4 seconds and goes on to an electronically limited top speed of 130 mph. What's more, it not only gives you even more power than its predecessor, it also offers significantly improved fuel consumption, thanks to technology such as spray-guided direct petrol injection, piezo injectors, twin turbochargers, variable camshaft control, intercooling and ECO start/stop.



This high-performance engine satisfies even the keenest of drivers – without sacrificing fuel efficiency



Transmissions

Designed for dynamic on-road performance and effortless off-roading, the 7-speed G-Class transmissions are carefully matched to their respective engines. What's more, they adapt automatically to different situations and driving styles.

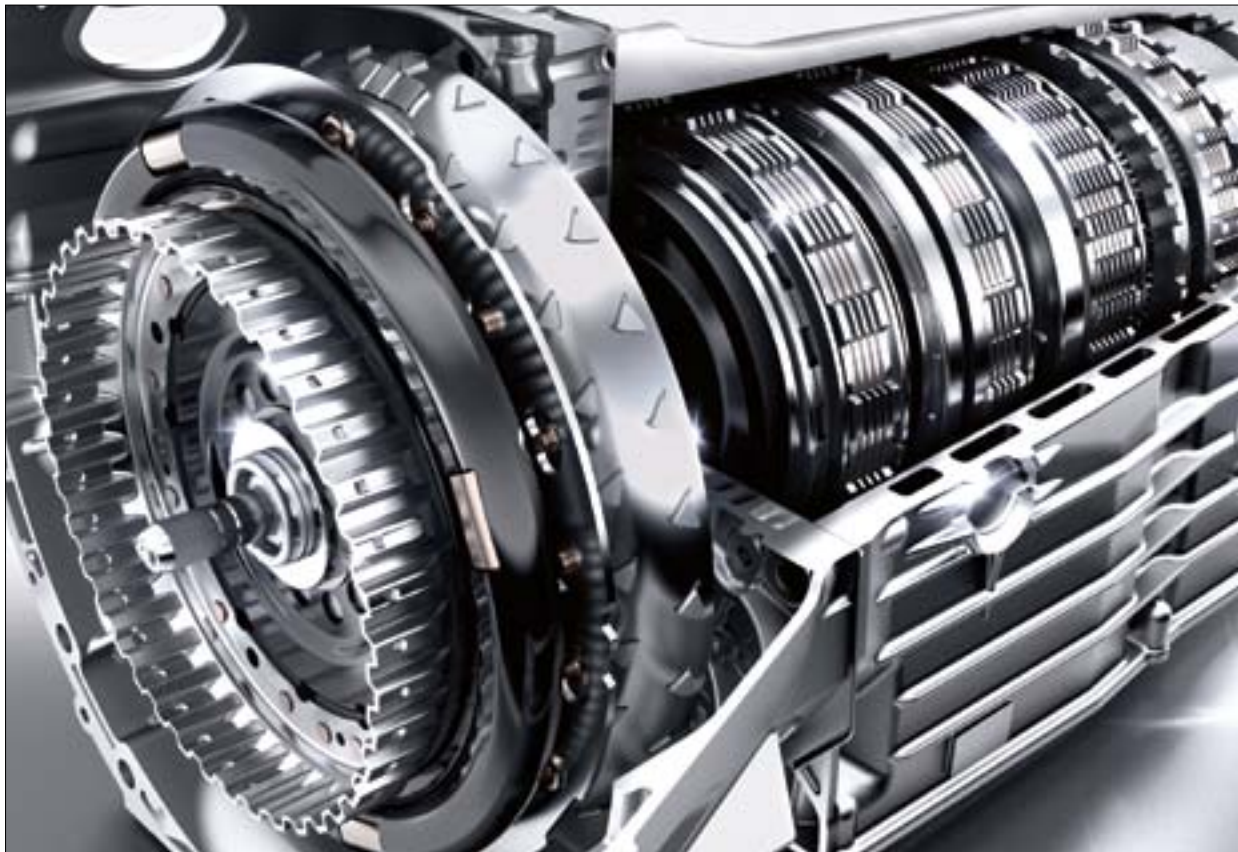

7G-Tronic Plus (standard on G 350 BlueTEC). With its exceptionally smooth gear changes, this 7-speed automatic transmission makes for a more effortless and enjoyable drive. The seven forward gears allow for ideally spaced ratios and ensure the engine is always operating at the ideal engine speed, resulting in almost imperceptible shifts as well as noticeably lower fuel consumption and noise levels. In kickdown, 7G-Tronic Plus can also skip individual gears for a more rapid response, jumping from seventh to fifth when overtaking for instance, while the extremely short shift times help to further enhance performance, giving you better off-roading, climbing and towing ability.

The G 350 BlueTEC's 7G-Tronic Plus 7-speed transmission offers supremely smooth gear changes





AMG Speedshift Plus 7G-Tronic transmission ensures the G 63 AMG's power is harnessed as effectively as possible

AMG Speedshift Plus 7G-Tronic (standard on G 63 AMG). The new G 63 AMG marks the G-Class debut of our AMG Speedshift Plus 7G-Tronic system, the state of the art in Mercedes-Benz transmission technology. This updated 7-speed automatic transmission is designed to cope with exceptionally high levels of torque, ensuring the G 63 AMG's 760 Nm is transferred smoothly and rapidly to the driven wheels. What's more, it offers exceptionally short shift times and uninterrupted acceleration.

ECO start/stop function (standard on G 63 AMG). Active in 'Controlled Efficiency' ('C') mode, the ECO start/stop function helps the G 63 AMG to achieve impressively low levels of fuel consumption by cutting the engine whenever the vehicle comes to a standstill. In addition, 'C' mode ensures you always pull away in second and benefit from earlier shift points – meaning enhanced low-range torque, greater fuel efficiency and lower CO₂ emissions.



Suspension

With its ladder-type frame, long-travel rigid-axle suspension and 21 cm of ground clearance, the G-Class takes almost any surface and obstacle in its stride.

Ladder-type frame. Its separate ladder-type chassis makes the G-Class tougher and more stress-resistant than off-roaders with unibody construction, helping to enhance longevity and resale value. Consisting of two parallel box-section members joined together via cross-members, the frame has a flexural strength that is particularly valuable in prolonged off-road use. The bodywork is screwed to the frame at eight different points and insulated from it via vibration-suppressing rubber bearings. For optimum corrosion resistance, the frame, hollow

sections and body panels are cathodic dip- and powder-coated, then carefully treated, waxed and painted, with the underbody benefiting from an additional plastic coating. As a result, the body is thoroughly protected against snow, salt and even Saharan sand. A key advantage of the highly rigid ladder frame can be seen in situations exerting high levels of torsional twist, with the chassis able to absorb twist forces so that these are not transferred to the bodywork. In addition, the fact that the ladder frame is always the lowest part of the body,

with only the axles protruding below it, helps to protect key components if the body comes into contact with the ground when off-roading.

Steering. The G-Class power steering is specially designed to meet the requirements of off-road driving. The absence of more easily worn parts such as steering gaiters and rubber bellows enhances durability and longevity, while the power assistance reduces effort compared with traditional recirculating ball systems and also softens the shocks to the driver's hand when driving over obstacles.



The ladder-type frame gives the G-Class exceptional stability and longevity



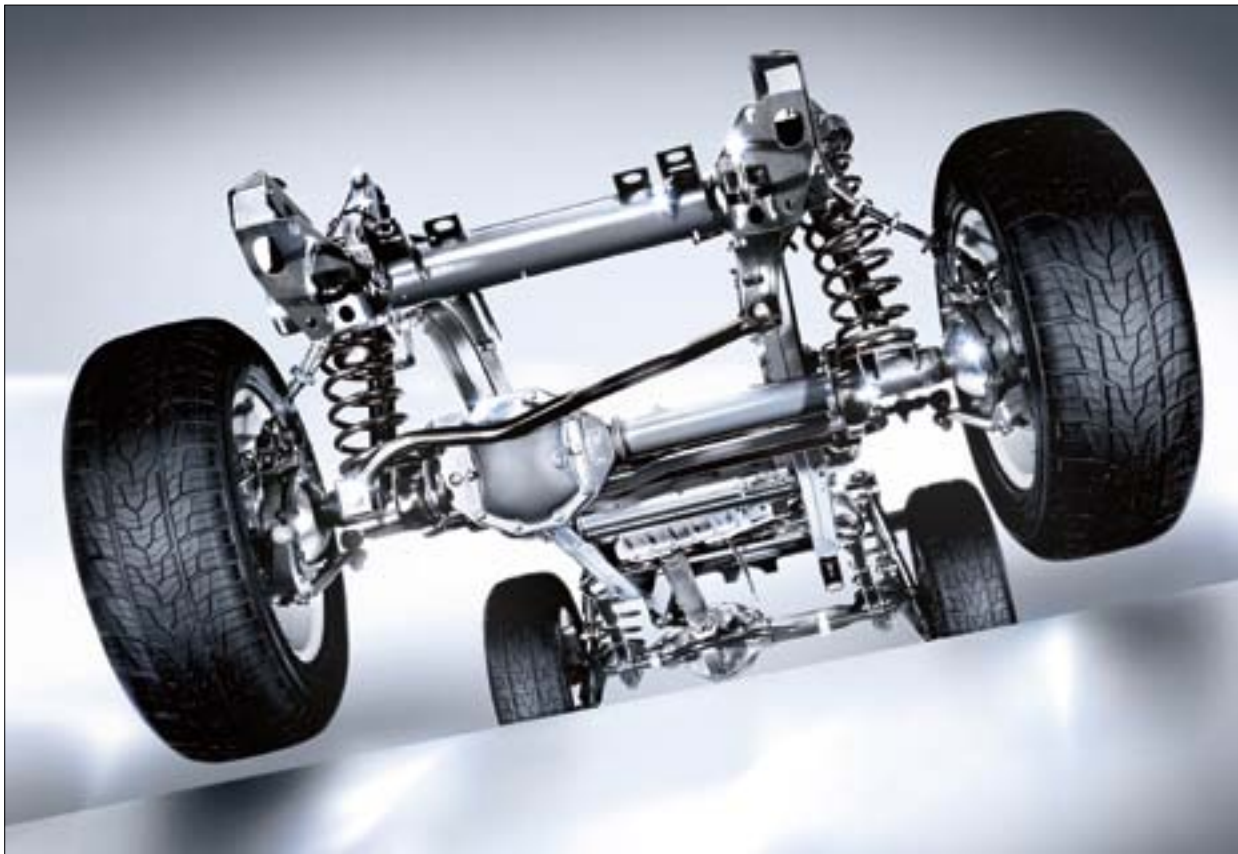

Rigid axles ensure high durability even with heavy off-road use, whilst maximising traction and enabling the vehicle's ground clearance to be maintained

Rigid-axle suspension. In off-road driving, the G-Class suspension, which features rigid axles with two solid trailing arms and a single control arm per axle, offers numerous advantages over road-biased independent suspension. Long-travel coil springs allow for a high degree of torsional twist, excellent ground clearance and outstanding traction, and also provide an agile and comfortable drive on tarmac. Gas struts help to prevent excess oscillation, twin anti-roll bars tailored to the vehicle's performance, unladen weight and payload capacity ensure lower levels of lean than on many off-roaders, and rigid steel shafts front and rear ensure the wheel camber on each axle remains unchanged. In addition, the even distribution of wheel load per axle, together with the ability to cope with higher angles of twist, increases durability, ensures ground clearance is unaffected by large obstacles and helps to maximise traction on demanding terrain.



On- and off-road technology

The G-Class offers outstanding off-road capabilities and keeps you moving even in tough terrain.

Permanent four-wheel drive with 4ETS. Working in harmony with the Four-Wheel Electronic Traction System (4ETS), three fully locking differentials and a synchromesh transfer case with off-road ratio, the G-Class four-wheel drive system provides optimum traction at all wheels, along with enhanced handling and stability. Its 50:50 torque split distributes power evenly between the front and rear wheels, while the differential gear system compensates for differences in rotational speed between the wheels, ensuring power is translated effectively into performance.

Part of the ESP® system, 4ETS can brake spinning wheels individually and direct the torque to the wheel or wheels offering the best traction in any given situation. As a result, the G-Class can pull away and accelerate even on difficult surfaces such as icy roads or tracks. In more rugged terrain, the rigid axles provide excellent ground clearance and outstanding traction, enabling you to get the best out of the permanent four-wheel drive system.

Locking differentials. Three electro-mechanically lockable differentials allow the G-Class to make headway even when only one of its wheels has traction. In tough terrain, buttons on the dashboard allow the front, centre and rear differentials to be locked sequentially according to your traction requirements. Locking all three differentials ensures the front and rear axles and the individual wheels on each axle are all turning at exactly the same speed, thus enabling the G-Class to extricate itself from tricky off-road situations using the traction of just a single wheel.

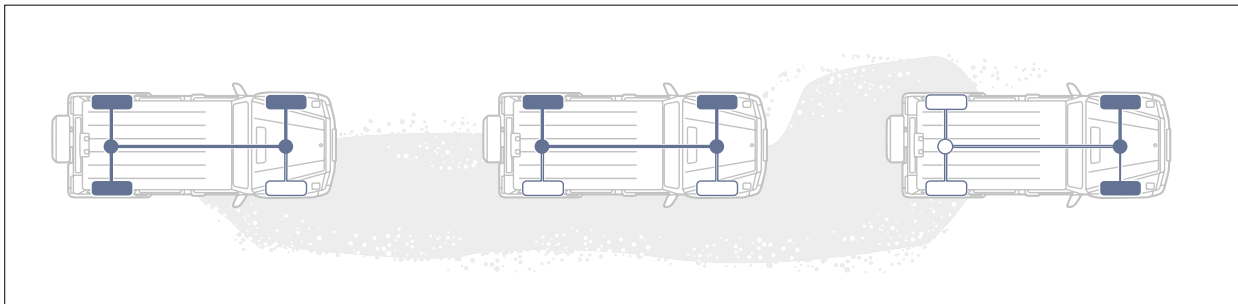

The Four-Wheel Electronic Traction System (4ETS) automatically transfers torque to the wheels with the most traction





Three sequentially lockable differentials help the G-Class to overcome even the toughest off-road situations



Off-road ratio (figures based on standard specification). Activated at speeds of approx. 25mph or below by simply pressing the 'low range' button, the 2-speed transfer case's off-road ratio is a real advantage when tackling

tough terrain. By optimising torque transfer at low speeds and thus improving pulling power and traction, it allows the G-Class to climb gradients of up to 80% and tackle difficult descents without locking the wheels.

The off-road ratio is particularly useful on slopes with slippery or varying surfaces such as rock, grass or snow, helping to maximise stability, maintain steerability and prevent the rear from breaking out.

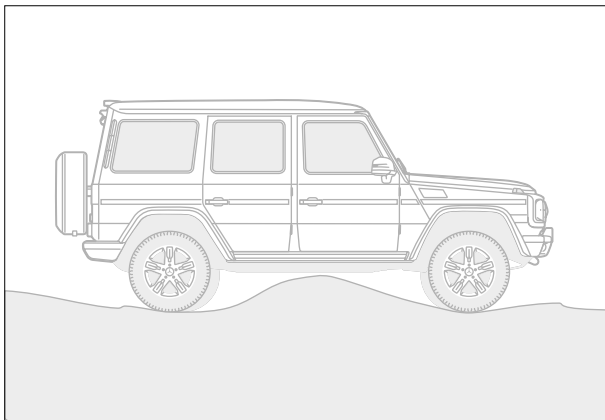

Ground clearance of 21 cm (22 cm on G 63 AMG)

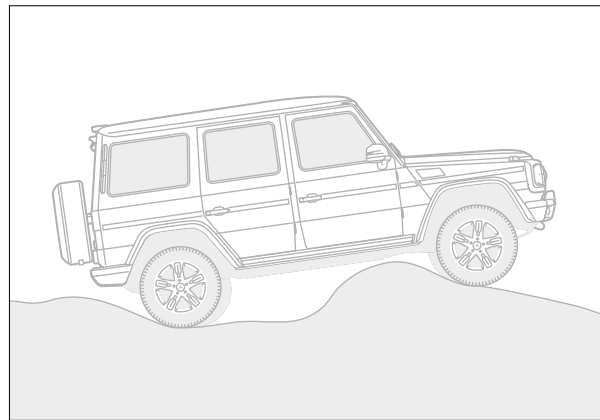

Large ramp breakover angle

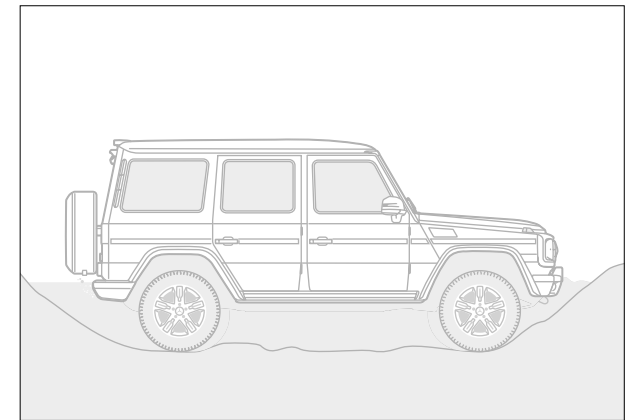

Maximum fording depth of 60 cm



Unique G-Class attributes. Only the G-Class offers the combination of 4ETS, 2-speed transfer case and three fully lockable differentials. Add in the two rigid axles and a protected drivetrain and you have a vehicle capable of

tackling almost any terrain and coping with extremely high levels of torsional twist. The G-Class climbs gradients of up to 80% (surface permitting), traverses slopes of up to 54% and fords up to 60 cm of water and mud. In

addition, it boasts a ground clearance of 21 cm (22 cm on G 63 AMG), with a correspondingly high breakover angle, and offers approach and departure angles of 36° (27° for G 63 AMG) and 27° respectively.

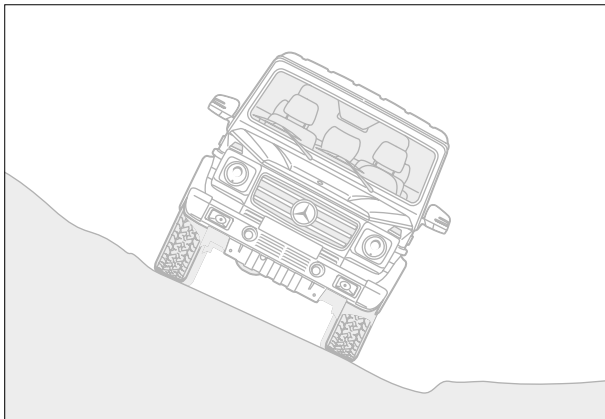

Directionally stable on slopes of up to 54%

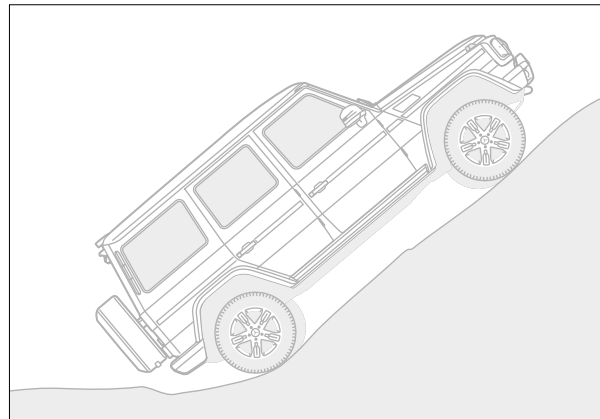

Climbs gradients of up to 80% (surface permitting)

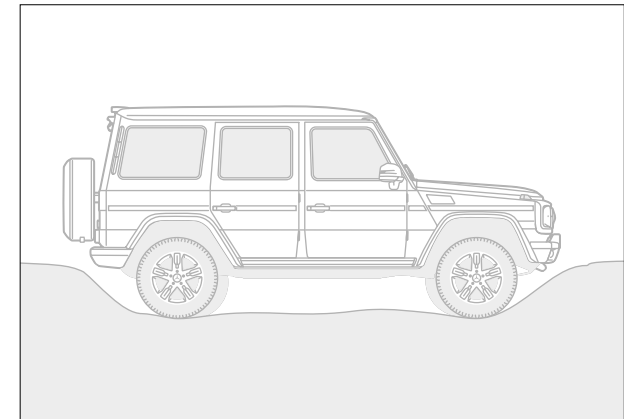

Max. approach angle 36° (27° for G 63 AMG), max. departure angle 27°



Integrated safety concept

The G-Class comes equipped with a range of systems that help to keep you and your passengers from harm. They include intelligent assistants that can intervene in order to avoid danger as well as features that help to protect the occupants should an accident prove unavoidable.

Electronic braking aids (standard). The Electronic Stability Programme (ESP®) can apply the brakes individually as the situation requires and, together with the anti-lock braking system (ABS), increase stability when cornering. It also optimises stability when towing, helping to counter trailer sway via the integral Trailer Stability Assist function.

Also fitted as standard is the Adaptive Brake System, whose hold function helps to prevent the vehicle from creeping forwards at traffic lights or in stop/start driving, and Brake Assist (BAS), which can detect emergency braking and ensure sufficient braking pressure is applied.

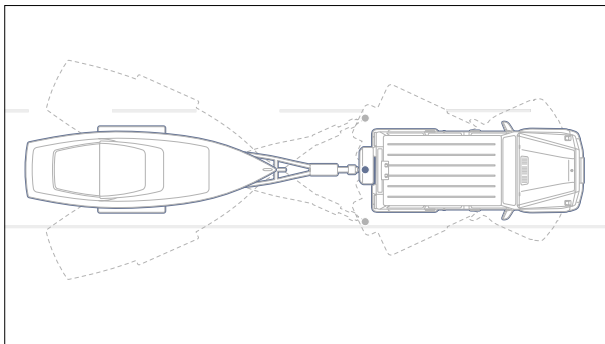

Trailer Stability Assist helps to increase safety when towing

LED daytime running lights (standard). Visually striking and more immediately visible, LED daytime running lights enhance both safety and style. Their LED strips are situated beneath the headlamps and housed within the headlamp casings.



LED daytime running lights enhance visibility and emphasise the distinctive G-Class looks

Neck-Pro comfort head restraints (standard). In the event of a rear-end collision, the Neck-Pro comfort front head restraints are raised approximately 30 millimetres and moved forward about 40 millimetres, ensuring the head is better supported and reducing the risk of whiplash injuries. In addition, they feature flexible side bolsters that further enhance side support and comfort.

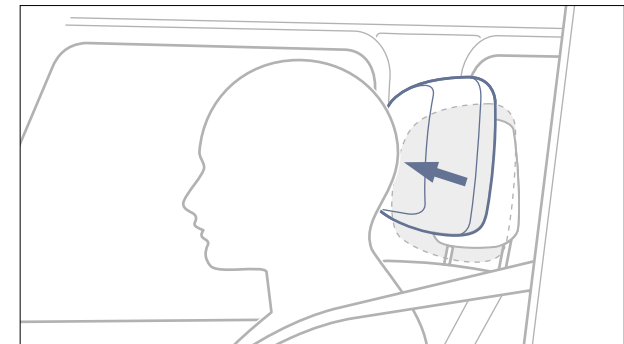

Neck-Pro comfort head restraints can reduce the risk of whiplash injury in rear-end collisions



Airbags and windowbags (standard). The G-Class is fitted with front airbags for the driver and front seat passenger plus windowbags for both rows of seats. The passenger's side airbag includes a seat occupancy sensor, while the driver's side airbag features dual-stage activation, inflating either partially or fully depending on the type and projected severity of the impact.

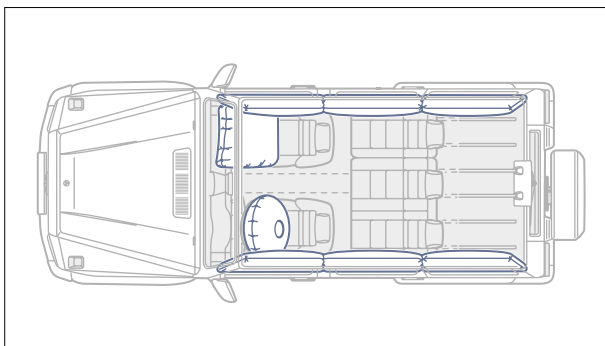

Airbags for the driver and front seat passenger and windowbags for both rows of seats are fitted as standard

Distronic Plus (optional). This radar-assisted cruise control system automatically maintains a preset distance from the vehicle in front, accelerating and braking automatically, thus making for more relaxed progress in high-speed driving or stop/start traffic. What's more, the heated radar sensor ensures it remains fully functional even in ice or snow. If the gap starts to decrease too rapidly, Distronic Plus emits an acoustic warning, while Brake Assist (BAS) intervenes if it detects emergency braking, ensuring sufficient brake force is applied.



Distronic Plus radar-assisted cruise control automatically maintains a set distance from the vehicle in front

Blind Spot Assist (optional). Active at speeds of above 19 mph, Blind Spot Assist monitors the hard-to-see areas to the rear and sides of the car. If it spots a potentially dangerous lane change, the system alerts the driver via a warning signal in the corresponding exterior mirror. If the driver then switches on the indicator on that side, an additional acoustic warning is sounded.



Blind Spot Assist helps you to avoid dangerous lane changes



G-Class design

Timeless looks and peerless versatility have made the G-Class a legend among off-roaders.

Styles come and go, but the G-Class simply endures. Now in its fourth decade, it boasts the same classic lines and clean surfaces that have always made it such a unique presence. Its large glass area features distinctively shaped load compartment windows, the side skirts, shoulder lines, roof lines and side rubbing strips are almost exactly parallel, and the high wheel arches and wide track, together with a rear that's slightly thicker at the base, add up to a sturdy-looking body with optimum off-road ability. Inside, the spacious G-Glass cabin is

supremely comfortable whatever the distance or weather, thanks to a 2,850 mm wheelbase, heat-insulating glass all round, and standard features such as heated seats front and rear. The G-Class accommodates equipment with ease too, offering up to 2,250 litres of luggage capacity and easy access via the large side-hinged tailgate. The standard $\frac{1}{3}:\frac{2}{3}$ split folding rear seat and load-securing points further enhance its versatility, while the optional load compartment cover and luggage net help to keep your cargo safe and secure. What's more,

with a maximum trailer load of 3.5 tonnes, the G-Class even enables you to tow boats, horseboxes or caravans over difficult surfaces.



Clean lines and distinctive style



Extreme durability combined with exceptional comfort



Space for all your equipment, whatever the expedition





The G350 BlueTEC's restyled front end



G 63 AMG

AMG technology meets go-anywhere ability – discover a driving experience without comparison. → www.mercedes-amg.com



With 544 hp (400 kW) from its AMG biturbo V8, 760 Nm of torque and fuel-saving features such as ECO start/stop, the G 63 AMG is a remarkable combination of exhilaration and efficiency. Visually, it's simply unmistakable, thanks to the AMG two-bar grille with chrome trim, AMG wheel arch extensions, 'V8 BITURBO' badges on the front wings and an AMG exhaust system with side-exiting twin chromed tailpipes. Also fitted as standard are the Exterior Styling Package and AMG 5-twin-spoke alloy wheels with Titanium Grey finish, red-painted brake calipers and 275/50 R 20 tyres.

The cabin is similarly special, with illuminated AMG stainless steel door sill panels, *designo* leather upholstery, leather trim for the dashboard and multi-function steering wheel, door panels in ruffled leather, ambient interior lighting, chrome trim and an Anthracite Alcantara® roof lining. There's also a choice of three *designo* wood trims and the option of AMG carbon-fibre trim for an even more dynamic look.





Multimedia systems

The G-Class multimedia systems help you to reach your destination as directly as possible – and keep you and your passengers entertained on the way.

COMAND Online system (standard). The COMAND Online system combines navigation, communication and Internet functions with a wide range of in-car entertainment features. These include a DVD drive, tuner, music library with a 10 GB hard drive, plus a Media Interface that allows connection of external devices, Bluetooth® interface and an SD memory card slot. The system can be operated via spoken commands courtesy of Linguatronic voice control and, in conjunction with an Internet-ready mobile phone, offers access to the Internet and to Mercedes-Benz apps. As an option, you can even equip



COMAND Online combines in-car entertainment, hard disk drive navigation and a high-resolution 7-inch central display

your G-Class with a TV tuner and watch television on the COMAND Online display.

Harman Kardon® Logic 7® surround sound system (standard). With its 10-channel DSP amplifier, 450-watt output and 3D spatial sound, this 12 high-performance speaker system delivers a first-class listening experience for all. It also features Dolby Digital 5.1 and speed-sensitive volume adjustment for optimum clarity and enjoyment at all times.



With 12 speakers, 450 watts and Logic 7® processing, the optional Harman Kardon® audio system delivers cabin-filling surround sound

Rear seat entertainment system (optional). This entertainment system gives rear seat passengers everything they need to watch films or use a games console without disturbing the driver. It comprises two DVD players, two independently operable 7-inch TFT colour displays attached to the backs of the front seat head restraints, two sets of wireless headphones, a remote control and twin aux-in sockets.



The rear seat entertainment system's twin displays are attached to the backs of the front seat head restraints



Parking assistants and Seat Comfort Package

The G-Class offers a range of options that further enhance seat comfort and make for more stress-free manoeuvring.

Reversing camera (optional). Activated automatically as soon as the driver engages reverse, this wide-angle camera captures the area immediately behind the car and displays the image on the COMAND Online display, making for safer and easier low-speed manoeuvres.

Parktronic parking aid (standard). Parktronic uses the sonar principle to help you avoid low-speed knocks during parking manoeuvres. It sends out ultrasound signals that reflect off other objects and are picked up by sensors in the front and rear bumpers. The system then processes this information and calculates the size of the gap, enabling it to alert you via acoustic and visual warnings as you approach the vehicle or object.

Seat Comfort Package (optional). Ventilated multi-contour front seats ensure even the longest journeys are a pleasure. They feature electric height adjustment, continuously variable tilt adjustment and adjustable lumbar supports that can help to prevent tiredness in the back.



The reversing camera uses the central display to show you what's immediately behind the car



Parktronic's LEDs indicate the distance from other objects when manoeuvring



Multi-contour seats can help you to stay comfortable and alert on long journeys



Standard equipment | Selection



Colour display in instrument panel



Sequentially lockable differentials



Central display



Electrically adjustable front seats with memory function



Automatic climate control



Harman Kardon® Logic 7® surround sound system



Ambient interior lighting



Bi-xenon headlamps with LED daytime running lights



Optional extras | Selection



Carbon-fibre interior trim



Rear seat entertainment system



Reversing camera



Blind Spot Assist



Electric sunroof



Distronic Plus



Tow bar



Privacy glass - dark glass from B-pillar backwards



Chrome Package

The optional Chrome Package adds elegance and individuality to your G-Class.



With its chrome-trimmed three-bar grille, the optional Chrome Package brings an extra touch of exclusivity to the G-Class exterior (standard on G 63 AMG, with model-specific two-bar grille). The enhancements also include chrome surrounds for the front door speakers and wood-trimmed seat adjustment consoles, plus a chromed load sill guard with 'Mercedes-Benz' or 'AMG' lettering according to the chosen model.



Exterior Styling Package

The refined look of stainless steel provides the perfect counterpoint to those rugged G-Class lines.



An elegant and eye-catching addition to any G-Class, the optional Exterior Styling Package (standard on G 63 AMG) comprises stainless steel running boards and a stainless steel spare wheel cover with 3D three-pointed star.



Sports Package

Available as an option for the G 350 BlueTEC, the Sports Package lends the G-Class a highly dynamic look.



Anthracite-striped side rubbing strips add a sporty accent



Spare wheel cover in stainless steel

The optional Sports Package features striking exterior enhancements such as AMG wheel arch extensions, Anthracite-striped inserts for the side rubbing strips and 5-twin-spoke alloy wheels in Titanium Grey with 265/60 R 18 tyres. It also adds the stainless steel running boards and spare wheel cover of the Exterior Styling Package, plus velour floor mats for the interior.





The Sports Package for the G 350 BlueTEC further emphasises the striking G-Class lines



Exclusive Package

More than lives up to its name: the Exclusive Package for the G 350 BlueTEC.



The optional Exclusive Package is an ideal starting point for those looking to individualise their G-Class. It includes ventilated multi-contour front seats (also available as part of the optional Seat Comfort Package). Illuminated door sill panels light the way in and out of the cabin, while an Anthracite Alcantara® roof lining further adds to the air of quality.



designo Exclusive Package

Simply exquisite: the *designo* Exclusive Package for the G 63 AMG.



With two-tone *designo* leather upholstery all round, the *designo* Exclusive Package makes this unique off-roader feel even more special. It offers a choice of six different colour combinations and features a distinctive diamond-pattern leather for the door panels and seat centre panels, while the dashboard also boasts sumptuous *designo* leather. The package is exclusive to the G 63 AMG and is only available in conjunction with the optional Seat Comfort Package.



Upholstery and trim





The Black interior scheme features leather upholstery and a grey roof lining. Anthracite Alcantara® roof lining is standard on the G 63 AMG and optional on the G 350 BlueTEC. The G 350 BlueTEC has a Black nappa leather steering wheel and Anthracite Poplar wood trim as standard, while a wood- and leather-trimmed steering wheel can be specified in conjunction with the optional Brown Burr Walnut wood interior trim. Also available are a variety of *designo* interior trim options, as well as carbon-fibre trim by AMG.

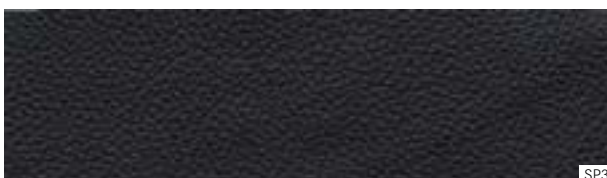

SP3



VF7



ZG8



V56



ZT0



ZG2



ZG6

Black

SP3 Leather¹

Trim

VF7 Anthracite Poplar wood¹V56 Brown Burr Walnut wood²ZG2 *designo* Black Piano Lacquer wood³ZG8 *designo* Champagne White Piano Lacquer wood²ZT0 *designo* Light Brown Poplar wood (matt finish)²ZG6 AMG carbon fibre⁴

¹Standard on G 350 BlueTEC, not available on G 63 AMG ²Optional on G 350 BlueTEC, no-cost option on G 63 AMG ³Optional on G 350 BlueTEC, standard on G 63 AMG ⁴Optional



The Alpaca Grey interior scheme features Alpaca Grey leather upholstery. The steering wheel, dashboard and carpets come in contrasting black. An Anthracite Alcantara® roof lining is standard on the G 63 AMG and optional on the G 350 BlueTEC. The G 350 BlueTEC has a Black nappa leather-trimmed steering wheel and Anthracite poplar wood trim as standard, while a wood-and leather-trimmed steering wheel can be specified in conjunction with the optional Brown Burr Walnut wood interior trim. A variety of *designo* interior trim options are also available, as well as carbon-fibre trim by AMG.



SP4



VF7



ZG8



V56



ZT0



ZG2



ZG6

Alpaca Grey

SP4 Leather¹

Trim

VF7 Anthracite Poplar wood¹

V56 Brown Burr Walnut wood²

ZG2 *designo* Black Piano Lacquer wood³

ZG8 *designo* Champagne White Piano Lacquer wood²

ZT0 *designo* Light Brown Poplar wood (matt finish)²

ZG6 AMG carbon fibre⁴

¹Standard on G 350 BlueTEC, not available on G 63 AMG ²Optional on G 350 BlueTEC, no-cost option on G 63 AMG ³Optional on G 350 BlueTEC, standard on G 63 AMG ⁴Optional



The Chestnut interior scheme features Chestnut leather upholstery and a grey roof lining, with an Anthracite Alcantara® roof lining available as an option (standard on the G 63 AMG). The steering wheel, dashboard and carpets come in contrasting black. The G 350 BlueTEC has a Black nappa leather-trimmed steering wheel and Anthracite Poplar wood trim as standard, while a wood-and leather-trimmed steering wheel can be specified in conjunction with the optional Brown Burr Walnut wood interior trim. A variety of *designo* interior trim options are also available, as well as carbon-fibre trim by AMG.



SP5



VF7



ZG8



V56



ZT0



ZG2



ZG6

Chestnut

SP5 Leather¹

Trim

VF7 Anthracite Poplar wood¹

V56 Brown Burr Walnut wood²

ZG2 *designo* Black Piano Lacquer wood³

ZG8 *designo* Champagne White Piano Lacquer wood²

ZT0 *designo* Light Brown Poplar wood (matt finish)²

ZG6 AMG carbon fibre⁴

¹Standard on G 350 BlueTEC, not available on G 63 AMG ²Optional on G 350 BlueTEC, no-cost option on G 63 AMG ³Optional on G 350 BlueTEC, standard on G 63 AMG ⁴Optional

designo

Individuality at its most alluring: *designo* offers a host of ways to make your G-Class even more distinctive. → www.mercedes-benz.co.uk/designo

Create a G-Class that's one of a kind – with exclusive *designo* paint finishes and sumptuous interior appointments hand-crafted from the finest materials. For the exterior, there's a choice of three *designo* metallic finishes (*designo* Mocha Black, Graphite and Platinum Black), three *designo* Mystic finishes (*designo* Mystic Blue, Mystic Red and Mystic Brown) and two *designo* Magno matt finishes (*designo* Magno Platinum and Magno Night Black).

Inside, hand-stitched *designo* leather upholstery brings an unmistakable air of luxury to the G-Class cabin. There are eight single-tone upholsteries to choose from (*designo* Porcelain, Marron, Classic Red, Black, Light Brown, Sand,

Mystic Red and Titan Pearl). Each comes with door panels in ruffled leather, velour floor mats edged in *designo* leather and an Anthracite Alcantara® roof lining. Single-tone *designo* leather upholstery comes as standard on the G 63 AMG and is available as an option on the G 350 BlueTEC. An eye-catching *designo* wood- and leather-trimmed steering wheel is also available as a separate option (standard on the G 63 AMG).

For an even more luxurious G 63 AMG, there's the optional *designo* Exclusive Package (only available in conjunction with the optional Seat Comfort Package). It gives you a choice of six two-tone *designo* leather upholsteries and also includes a *designo* leather-covered dashboard.





ZF7



VF7



V56



ZG2



ZG8

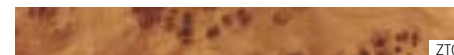

ZT0

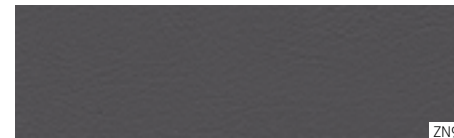

ZG6

designo Black leather (optional)ZF7 *designo* leather¹**Trim**VF7 Anthracite Poplar wood²V56 Brown Burr Walnut wood³ZG2 *designo* Black Piano Lacquer wood¹ZG8 *designo* Champagne White Piano Lacquer wood³ZT0 *designo* Light Brown Poplar wood (matt finish)³ZG6 AMG carbon fibre⁴

ZN9



VF7



ZG2



ZG6

designo Titan Pearl leather (optional)ZN9 *designo* leather¹**Trim**VF7 Anthracite Poplar wood²ZG2 *designo* Black Piano Lacquer wood¹ZG6 AMG carbon fibre⁴¹Optional, standard on G 63 AMG ²Standard on G 350 BlueTEC, not available on G 63 AMG ³Optional on G 350 BlueTEC, no-cost option on G 63 AMG ⁴Optional



ZF4



VF7



V56



ZG2



ZG8

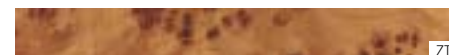

ZT0



ZG6

designo Marron leather (optional)

ZF4 *designo* leather^{1,2}

Trim

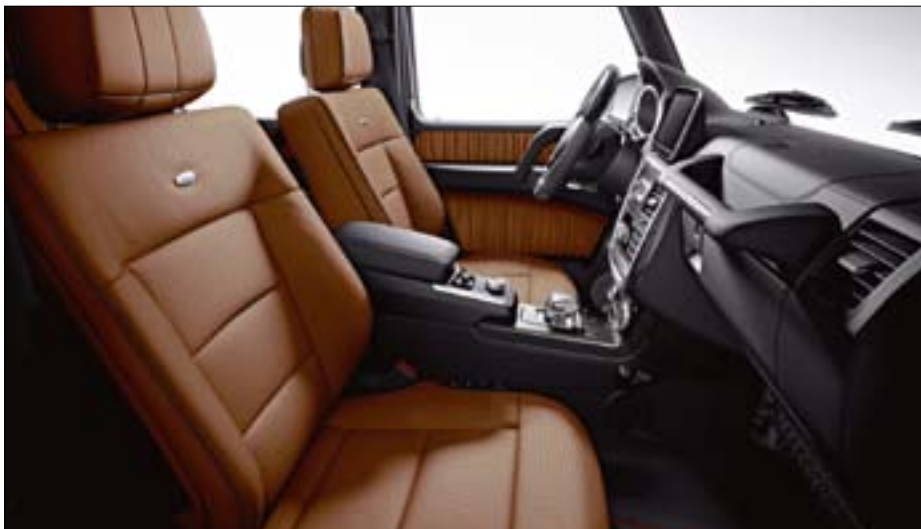
VF7 Anthracite Poplar wood³V56 Brown Burr Walnut wood¹ZG2 *designo* Black Piano Lacquer wood⁴ZG8 *designo* Champagne White Piano Lacquer wood¹ZT0 *designo* Light Brown Poplar wood (matt finish)¹ZG6 AMG carbon fibre⁵

ZF2



VF7



V56



ZG2



ZG8



ZT0



ZG6

designo Light Brown leather (optional)

ZH2 *designo* leather¹

Trim

VF7 Anthracite Poplar wood³V56 Brown Burr Walnut wood¹ZG2 *designo* Black Piano Lacquer wood⁴ZG8 *designo* Champagne White Piano Lacquer wood¹ZT0 *designo* Light Brown Poplar wood (matt finish)¹ZG6 AMG carbon fibre⁵



ZK6



VF7



V56



ZG2



ZG8

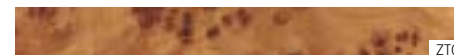

ZT0



ZG6

designo Sand leather (optional)ZK6 *designo* leather¹**Trim**VF7 Anthracite Poplar wood²V56 Brown Burr Walnut wood¹ZG2 *designo* Black Piano Lacquer wood³ZG8 *designo* Champagne White Piano Lacquer wood¹ZT0 *designo* Light Brown Poplar wood (matt finish)¹ZG6 AMG carbon fibre⁴

ZK8



VF7



V56



ZG2



ZG8



ZT0



ZG6

designo Mystic Red leather (optional)ZK8 *designo* leather^{1,5}**Trim**VF7 Anthracite Poplar wood²V56 Brown Burr Walnut wood¹ZG2 *designo* Black Piano Lacquer wood³ZG8 *designo* Champagne White Piano Lacquer wood¹ZT0 *designo* Light Brown Poplar wood (matt finish)¹ZG6 AMG carbon fibre⁴

¹Optional on G 350 BlueTEC, no-cost option on G 63 AMG ²Standard on G 350 BlueTEC, not available for G 63 AMG ³Optional, standard on G 63 AMG ⁴Optional ⁵Not available in conjunction with *designo* Exclusive Package (PA6)



ZF5



VF7



V56



ZG2



ZG8



ZT0



ZG6

designo Classic Red leather (optional)

ZF5 *designo* leather¹

Trim

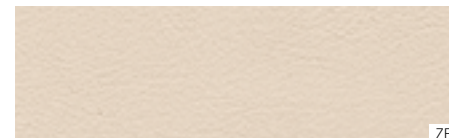
VF7 Anthracite Poplar wood²V56 Brown Burr Walnut wood³ZG2 *designo* Black Piano Lacquer wood³ZG8 *designo* Champagne White Piano Lacquer wood¹ZT0 *designo* Light Brown Poplar wood (matt finish)¹ZG6 AMG carbon fibre⁴

ZF3



VF7



V56



ZG2



ZG8



ZT0



ZG6

designo Porcelain leather (optional)

ZF3 *designo* leather¹

Trim

VF7 Anthracite Poplar wood²V56 Brown Burr Walnut wood³ZG2 *designo* Black Piano Lacquer³ woodZG8 *designo* Champagne White Piano Lacquer wood¹ZT0 *designo* Light Brown Poplar wood (matt finish)¹ZG6 AMG carbon fibre⁴

¹Optional on G 350 BlueTEC, no-cost option on G 63 AMG ²Standard on G 350 BlueTEC, not available for G 63 AMG ³Optional, standard on G 63 AMG ⁴Optional

Alloy wheels



18" 5-twin-spoke alloy wheels with 265/60 R18 tyres (standard on G350 BlueTEC, code RM9)



18" 5-spoke alloy wheels with burnished Titanium Grey finish and 265/60 R18 tyres (optional on G350 BlueTEC, code RL5)



20" AMG 5-twin-spoke alloy wheels with burnished Titanium Grey finish and 275/50 R20 tyres (standard on G63 AMG, code R10)



18" 5-twin-spoke alloy wheels with Titanium Grey finish and 265/60 R18 tyres (only available as part of the optional Sports Package, code RM9)



18" 6-spoke alloy wheels with burnished finish and 265/60 R18 tyres (optional on G350 BlueTEC, code RL6)



20" AMG 5-spoke alloy wheels with burnished matt Black finish and 275/50 R20 tyres (optional on G63 AMG, code R11)



Services

Test drive. Words can only do so much. Some things have to be experienced to be truly appreciated. Which is why we'd like to invite you for a test drive. Feel the power of efficient engines that offer impressive fuel consumption. Feel exhilarated by precise steering, designed to connect the driver with the road and enjoy sumptuous levels of comfort. Your Mercedes-Benz Retailer will be happy to make arrangements for you to experience the things that set a Mercedes-Benz apart. Alternatively, to request a test drive online simply visit www.mercedes-benz.co.uk/testdrive. We look forward to seeing you.

Mercedes-Benz Finance. At Mercedes-Benz Finance, our single-minded aim is to provide optimum financial solutions for all those who share the Mercedes-Benz philosophy of absolute commitment to quality. Whether you are a private customer or a business user, our finance and leasing packages can be tailored to meet your individual needs. For further information on Mercedes-Benz Finance, please contact your local Mercedes-Benz Retailer.

Mercedes-Benz Insurance offers a fully comprehensive 5 star¹ Motor Insurance policy specifically designed to give you the cover you would expect from Mercedes-Benz. For a quotation, please call 0845 600 2180²

Interactive Owner's Manual. The website also offers an interactive tour, enabling you to take a closer look at your desired model. This simulation is the ideal way to acquaint yourself with your dream car. You can view key functions in detail, gain an insight into the car's inner workings or look at the benefits of each model. For further details, visit www.mercedes-benz.co.uk/gclassmanual

Roadside Assistance. Rest assured that should you ever need help, Mercedes-Benz Roadside Assistance is there for you. In the unlikely event of a technical



breakdown³ you can rely on the Mercedes-Benz Roadside Assistance Team – anywhere in Europe. Simply phone our Customer Assistance Centre on 00800 1 777 7777,⁴ where our specialists will organise assistance for you. Mercedes-Benz will also assist you in the event of a minor mishap preventing you from driving your vehicle.³ Whether you lose your key, run out of fuel or your vehicle is damaged due to an accident or vandalism, Mercedes-Benz ensures that you still reach your destination. Often the problem can be rectified on the spot, but if this is not possible, we will naturally ensure that your vehicle is taken to the nearest Mercedes-Benz Official Workshop to get you back on the road as quickly as possible.

Mercedes-Benz World at Brooklands. Celebrate the story of Mercedes-Benz and you'll celebrate the story of motoring itself at Mercedes-Benz World in Surrey. A World of experiences. Discover Mercedes-Benz racing heritage, from its connections to the famous Brooklands circuit through to present-day Formula 1™ brought to life



in the most sensational way. View, touch and sit in every car from the Mercedes-Benz range, and encounter automotive legends like the 'Gullwing' and many other classic icons, in the UK's largest Mercedes-Benz showcase. Then set your pulse racing by booking one of our thrilling Driving Experiences. Enjoy AMG performance on the purpose-built Handling Circuits or Wet Skid Circle, an axle-twisting off-road adventure, or treat your kids over 1.5 metres tall to their own driving experience in an A-Class or on the off-road terrain in an M-Class. And for kids even younger and under 1.3 metres tall, let them be a 'Little Learner' in their own miniature electric version of the desirable Mercedes-Benz SL. For more interactive action, take a virtual 3D journey along the production line in 'Build' and take a seat in the cinema to accelerate from the birth of the car to the latest innovations in 20 eye-opening minutes.

Relax and refuel in Café 1886, or for something more enjoy the delicious menu and elegant surroundings of the Gullwing Restaurant. Finally, extend your visit with a short stroll to Brooklands Museum to see their collection of classic cars, aviation exhibitions – and the legendary Concorde. For more information visit www.mercedes-benzworld.co.uk

¹ As rated by Defaqto, a leading UK independent financial research company.
Mercedes-Benz Motor Insurance is underwritten by Aviva Insurance Limited
² Calls are charged at local rate and may be recorded

³ Cover is initially valid for your vehicle for four years from the date of first registration. This can be extended from the fifth year, up to a maximum of 30 years, on completion of each scheduled maintenance service, providing that this service is carried out by a Mercedes-Benz

Official Workshop. Minor mishap cover is provided at the absolute discretion of Mercedes-Benz
⁴ In non-affiliated European countries: +44 20 7975 7077



Dimensions

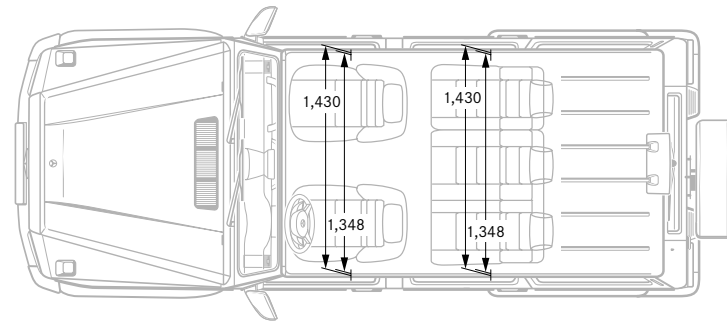
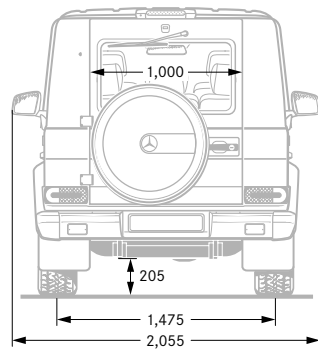
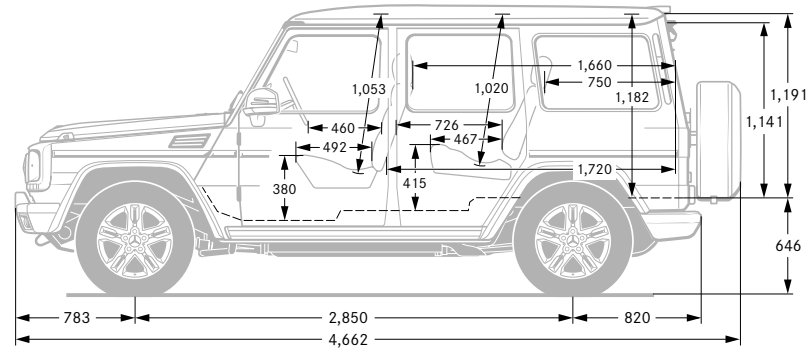
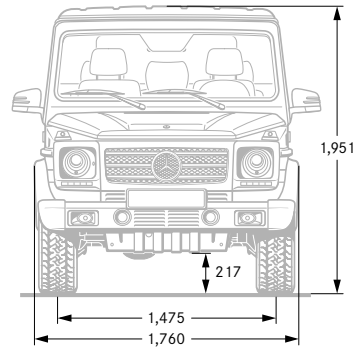

All measurements in millimetres. The dimensions shown are mean values and apply to standard-specification, unladen vehicles



Technical data

	Diesel engine	AMG petrol engine
	G 350 BlueTEC	G 63 AMG
Arrangement/cylinders/valves	V/6/24	V/8/32
Capacity – cc	2,987	5,461
Power ¹ – hp (kW) at rpm	211 (155)/3,400	544 (400)/5,500
Torque ¹ – Nm at rpm	540/1,600–2,400	760/2,000–5,000
Compression ratio	17.7:1	10.0:1
Acceleration 0–62 mph – sec	9.1	5.4
Top speed, approx. – mph	108	130 ⁴
Tyre size	265/60 R 18	275/50 R 20
Fuel	Diesel	Super
Fuel consumption ² – mpg		
Urban	20.8	16.4
Extra-urban	28.8	23.9
Combined	25.2	20.5
CO ₂ emissions, combined ² – g/km	295	322
EU emissions standard	Euro 5	Euro 5
Fuel tank capacity/of which reserve – l	96/14	96/14
Turning circle – m	13.6	13.6
Kerb weight ³ /Perm. Gross Vehicle Weight – kg	2,570/3,200	2,550/3,200
Towing capacity, braked/unbraked – kg	3,500/750	3,500/750

¹ Figures in accordance with Directive 80/1269/EEC in the currently applicable version ² The figures shown were obtained in accordance with the prescribed measuring process (Directive 80/1268/EEC in the currently applicable version).

³ Figures according to Directive 92/21/EC, version 95/48/EC (kerb weight with fuel tank 90% full, driver, 68 kg, and luggage, 7 kg) for standard-specification vehicles. Optional extras and accessories will generally increase this figure and reduce the payload capacity accordingly. The figures are not based on an individual model and do not constitute part of the product offer; they are provided solely for purposes of comparison between different vehicle models ⁴ Electronically limited



Paint finishes

Non-metallic paints

(no-cost option)

040 Black

650 Calcite White

Metallic paints (standard)

183 Magnetite Black

197 Obsidian Black

300 Periclase Green

359 Tanzanite Blue

474 Peridot Brown

541 Thulite Red

755 Tenorite Grey

775 Iridium Silver

792 Palladium Silver

798 Sandine Beige

963 Indium Grey

designo paints (optional)

033 *designo* Mocca Black

041 *designo* Graphite

046 *designo* Platinum Black

032 *designo* Mystic Blue

037 *designo* Mystic Red

052 *designo* Mystic Brown

051 *designo* Magno Platinum

056 *designo* Magno Night Black

Non-metallic paints



040



650

Metallic paints



183



197



300



359



474



541



755



775



792



798



963

designo paints



033



041



046



032



037



052

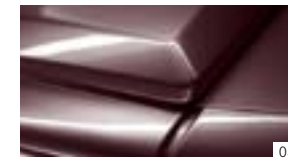

051



052



051



056



Take-back of end-of-life vehicles. Coming full circle. At the end of its long life, you can return your G-Class to us for environment-friendly disposal in accordance with the EC End-of-Life Vehicle Directive.¹ But that day lies a long way off.

¹Applies in accordance with national regulations to vehicles up to 3.5 tonnes permissible gross weight. The G-Class has met the statutory regulations governing the suitability of the vehicle's design for reuse and recycling for a number of years now. A network of vehicle take-back depots and dismantlers has been established which will process your vehicle in an environment-friendly manner. The ways in which both vehicles and parts can be recovered are subject to ongoing development and improvement. Consequently, the G-Class will be able to comply with any future increases in the recycling quota within the stipulated time limits. Further information is available at www.mercedes-benz.co.uk or by calling 00800 1 777 7777.

Please note: this online version of the printed brochure may contain abridged copy or other content changes. The manufacturer reserves the right to make changes to the design, form, colour and specification during the delivery period, provided these changes, while taking into account the interests of the vendor, can be deemed reasonable with respect to the purchaser. Where the vendor or the manufacturer uses symbols or numbers to describe an order or the subject of an order, no rights may be derived solely from these. The illustrations may show accessories and items of optional equipment which are not part of standard specification. Colours may differ slightly from those shown in the brochure, owing to the limitations of the printing process. This brochure has been compiled by Daimler AG of Germany and is distributed internationally. It provides a general indication of the range of models, features, optional extras and/or colours available in various countries. Some of the models, features, optional extras and/or colours shown may not be available in your country or may only be available in a different specification. Additionally some models, features, optional extras and/or colours may only be available in combination with others. For current and more specific information in relation to the range of models, features, optional extras and/or colours available in your country, and their pricing, you should contact your nearest authorised Mercedes-Benz Retailer. E&OE. www.mercedes-benz.co.uk

