

SL-Class



Mercedes-Benz





What legends are made of: pure exaltation

More than 50 years ago saw the birth of a car that was to be crowned 'sports car of the century'. It was of course the legendary 300 SL, pioneering a great sports car tradition. Today, a new era has begun: the latest incarnation of the SL strikes a dazzling pose, and so the legend continues.



A dream designed for the real world

It's hard not to get carried away by the beauty of the SL. Yet it's right on the ball when the situation commands it and makes sure you are too. A whole range of intelligent safety features with almost any electronic driving assistant system you could wish for ensures the SL is one of the safest cars in the world. Just as you'd expect. After all, the SL is the Mercedes amongst roadsters.





A high-angle, close-up photograph of the rear passenger area of a car. The focus is on the leather-upholstered seats, which feature a perforated pattern on the lower backrest and seat cushion. The side panel of the rear seat is also perforated and has a small, oval-shaped speaker grille. The car's interior is dark, and the exterior view through the window shows a parking lot with yellow double lines and a concrete pillar. The overall lighting is dramatic, highlighting the textures of the leather and the perforations.

Nothing but luxury

Sometimes choosing not to have something is more rewarding. That's why there are certain things you won't find in this stunning roadster. For example, bass speakers in the doors. Instead, the side members are in charge of the acoustics. Resonating bodywork, now that's a first. And the sound is just as brilliant for it.





From 0 to smile in a split second

Vario-roof down, accelerator floored – that's how you release happy hormones. The new SL is built for euphoria. A true athlete, it sprints as fast as the adrenaline rushes through your veins. Yet, even at a standstill it has the capacity for exaltation, gripping every inch of your body.

Sportiness

The Mercedes of sports cars. A new SL is always created with one aim in mind: to build the most elegant sports car in the world. The latest incarnation is the sportiest luxury roadster of all time. It features aluminium bodywork and lightweight build for a very low body weight. The new active suspension system, Active Body Control ABC (optional), achieves the perfect balance between driving dynamics and driving comfort. This unique system works with special sensors monitoring road conditions, sending signals within milliseconds to activate the four struts. As a result, the drive feels both more involved and more comfortable than ever.

- Efficient BlueDIRECT engines featuring more power and significantly lower fuel consumption than its predecessor
- Aluminium bodywork
- Adjustable Adaptive Damping System (standard)
- New Active Body Control (ABC) with greater differentiation between Sport and Comfort mode (optional)
- AMG Sports Package with sports suspension (optional)
- Torque Vectoring Brake for dynamic drive through corners

Design

The *magnum opus* for designers. There can hardly be a greater honour than to design an SL. Nor a greater challenge. The designers are faced with the great task of creating a harmonious blend between legendary traditional SL elements and pioneering, innovative design. The result is a thrilling SL, striking a truly individual pose with its long, slender shape, clear lines and powerfully moulded surfaces. The wide air intake and uniquely moulded headlamps set far apart add to the strong, masculine appearance. A typical SL look, reinforced by LED navigation and daytime running lights. The equally eye-catching shoulder line stretches like a taut muscle across the entire length of the car, culminating in the rear lights. The interior offers further excitement: precision engineering meets premium quality with an abundance of wood, leather and aluminium appointed with the greatest care and attention to detail, as seen, for example, on the sports steering wheel with nappa leather trim, or the turbine-inspired air vents.

- Sporty, masculine design with dynamic lines
- 3-spoke multi-function steering wheel with nappa leather trim and flattened lower section
- Sporty Direct Select gear selector in the centre console
- Advanced sports seats
- Premium quality feel thanks to generous use of wood and aluminium trim
- Optional ambient lighting

SL-Class. Athletic, aesthetic.

Open-top driving

Opens your heart. In less than 20 seconds the SL sports coupé can be transformed into a pedigree roadster. If you wish, you can watch this spectacle from afar, as the roof vanishes into the luggage compartment at a touch of the remote control. Airscarf ensures a longer open-top driving season when the temperature drops. It features two wind deflectors (one mechanical and one electric) especially devised for high speeds. On sunny days, the leather upholstery with an anti-reflective coating keeps the seats cool, adding to your comfort. If you prefer to keep the roof up, you can still admire the blue sky above, thanks to the optional vario-roof with Magic Sky Control, which switches from transparent to tinted at the touch of a button.

- Fully retractable Mercedes-Benz vario-roof
- Transparent panoramic vario-roof with blind (optional)
- Optionally with electric transparent panoramic vario-roof with Magic Sky Control
- Wind deflector, electric (optional)
- Airscarf wraps warm air around the head and neck area of both driver and passenger (optional)
- FrontBass® technology (world premiere) for excellent acoustics when driving with the top down
- Leather upholstery with anti-reflective coating reduces solar radiation and keeps seats significantly cooler

Safety

Benchmark driving. A high performance sports car like the SL comes with a great sense of responsibility. Thanks to a range of highly intelligent electronic assistants, the SL is equipped to provide the best possible safety. For example, the Intelligent Light System automatically adjusts to different traffic situations, whilst optional radar sensors monitor the road. When necessary, a range of electronic assistants and safety systems can alert the driver with visual, acoustic and tactile warning signals or actively intervene to reduce the risk of accidents. If a collision seems unavoidable, the Pre-Safe® Brake (as part of the Driving Assistance Package) can initiate an emergency stop, thereby reducing the severity of the impact. Additionally, adaptive airbags and, if required, the unique roll-over protection can be activated.

- Part-LED hybrid headlamps including Intelligent Light System and Adaptive High Beam Assist
- Multi-stage front airbags with newly developed sidebags
- Crash-active Neck-Pro head restraints
- Pre-Safe® anticipatory safety system
- Attention Assist
- Active Park Assist (optional)
- Driving Assistance Package (optional, features Distronic Plus including Pre-Safe® Brake and Brake Assist (BAS Plus), Active Blind Spot Assist and Active Lane-Keeping Assist)

Lightweight design



The new SL employs a consistently lightweight construction with an aluminum body

Less is more. The new SL weighs over 100 kilos less than its predecessor. Whilst its bodywork consists almost entirely of aluminium, systematic lightweight design and a whole range of intelligent solutions help to reduce the weight even further. For example, the lightweight rear axle has been combined with a tube-in-tube concept and slim hollow sections. Equally, the side members feature hollow casting. However, none of this impairs the stability of the SL. On the contrary, the sum of all these measures guarantees a light, yet torsionally rigid bodywork with an excellent stiffness-to-weight ratio. In fact, the torsional rigidity has been improved by approximately 20% compared to the SL's predecessor. As a result, the systematic use of aluminium has not only made the SL lighter, but also more agile, more efficient and safer.

Standard equipment

In the SL, the exceptional is the norm. Starting with the vario-roof painted in body colour. It simply vanishes into the luggage compartment at the touch of a button. For a dynamic and comfortable drive, the new SL features Direct Steering for improved handling and minimum steering effort. You can test the SL's agility to its limits thanks to a Torque Vectoring Brake, which targets the wheels precisely with the required force. Additionally, the 7G-Tronic Plus automatic transmission ensures optimum engine speed, low fuel consumption and smooth gear changes.

Inside the SL comfort abounds with features like the multi-function steering wheel with nappa leather trim, ergonomic seats with Memory Package or the elegant leather-trimmed gear selector. The COMAND Online system combines telephone, audio and video functions plus hard drive-based navigation in one easy-to-use unit as well as providing Internet access. For truly brilliant acoustics, the SL sound system is fitted with world premiere FrontBass® technology.

And to ensure optimum safety, headlamps with Intelligent Light System, LED daytime running lights, Attention Assist and Pre-Safe® anticipatory safety system also come as standard.



The Adaptive Damping System ADS can be individually adjusted at the touch of a button

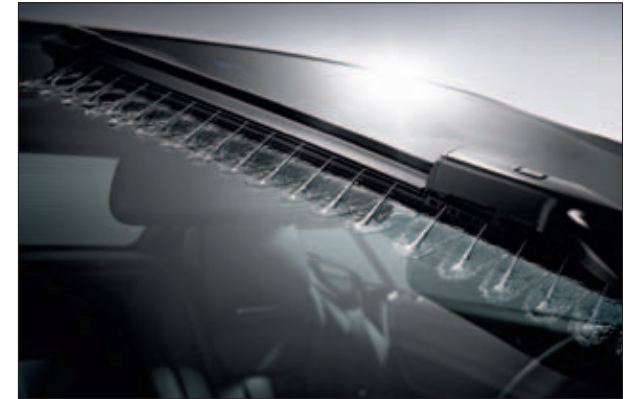

World premiere: the Adaptive Windscreen Wiper System



Ergonomics at their best: the Direct Select gear selector in the centre console



The multi-function steering wheel with nappa leather and gear shift paddles

Optional equipment

It's hard to improve perfection. But you can always put your own spin on it. The new SL offers plenty of optional extras to suit almost any individual requirement. There's the panoramic vario-roof with Magic Sky Control that can be dimmed at the touch of a button. Airscarf adds to your comfort when driving with the top down. And the improved suspension with Active Body Control ABC can be adjusted to Sport or Comfort mode. To enhance the

dynamic side of the SL, opt for the AMG Sports Package. It features AMG front and rear aprons and side skirts, 19" AMG alloy wheels and 10 mm lower sports suspension for a tighter, more athletic drive. It also includes seats with model-specific vertical fluting and perforated leather with piping in *designo* Platinum White Pearl on door armrests, centre console, seat side bolsters and head restraints.¹ For increased safety on the road, the SL can be fitted

with the Driving Assistance Package. It features DISTRONIC Plus, Active Blind Spot Assist, Active Lane-Keeping Assist, Brake Assist (BAS Plus) and Pre-Safe[®] Brake. The interior can be further enhanced with active multi-contour seats including massage function, a digital TV tuner and many other optional features.



AMG Sports Package

¹Upholstery codes 211, 511 and 811



High-end surround sound with Bang & Olufsen BeoSound AMG



Active multi-contour seats including massage function



Ambient lighting for instrument panel and doors



Seats with Airscarf vents



Electric wind deflector for comfortable top-down driving



Panoramic vario-roof with Magic Sky Control

METALLIC PAINTS¹



183 Magnetite Black



197 Obsidian Black



281 Cerrusite Grey (matt finish)²

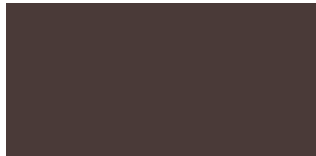

526 Dolomite Brown



755 Tenorite Grey



775 Iridium Silver

METALLIC PAINTS¹



792 Palladium Silver



794 Pearl Beige

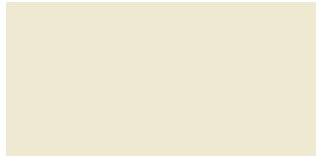

799 Diamond White²



890 Cavansite Blue

NON-METALLIC PAINTS³



040 Black



590 Fire Opal



designo SPECIAL PAINT^{2,5}



057 *designo* Zircon Red

BLACK



201 Leather¹ | 801 Nappa leather⁴
501 Exclusive Nappa leather⁴



211 Leather^{6,7} | 811 Nappa leather^{4,7}
511 Exclusive Nappa leather^{4,7}



736 High-Gloss Black Ash wood⁴



739 Light brushed aluminium^{4,6,8}



731 High-Gloss Brown Burr Walnut wood^{4,9}



729 Matt Light Brown Poplar wood⁴



H76 Dark brushed aluminium^{4,9,10}

CRYSTAL GREY



208 Leather¹



736 High-Gloss Black Ash wood⁴



739 Light brushed aluminium^{4,6,8}



731 High-Gloss Brown Burr Walnut wood^{4,9}



729 Matt Light Brown Poplar wood⁴

GINGER BEIGE/ESPRESSO BROWN



205 Leather¹ | 805 Nappa leather⁴
505 Exclusive Nappa leather⁴



736 High-Gloss Black Ash wood⁴



739 Light brushed aluminium^{4,6,8}



731 High-Gloss Brown Burr Walnut wood^{4,9}



729 Matt Light Brown Poplar wood⁴

PORCELAIN



815 Nappa leather⁴
515 Exclusive Nappa leather⁴



736 High-Gloss Black Ash wood⁴



739 Light brushed aluminium^{4,6,8}



731 High-Gloss Brown Burr Walnut wood^{4,9}



729 Matt Light Brown Poplar wood⁴

BENGAL RED



207 Leather¹ | 807 Nappa leather⁴
507 Exclusive Nappa leather⁴



736 High-Gloss Black Ash wood⁴



739 Light brushed aluminium^{4,6,8}



731 High-Gloss Brown Burr Walnut wood^{4,9}



729 Matt Light Brown Poplar wood⁴

NUT BROWN



804 Nappa leather⁴
504 Exclusive Nappa leather⁴



736 High-Gloss Black Ash wood⁴



739 Light brushed aluminium^{4,6,8}



731 High-Gloss Brown Burr Walnut wood^{4,9}



729 Matt Light Brown Poplar wood⁴

Dimensions

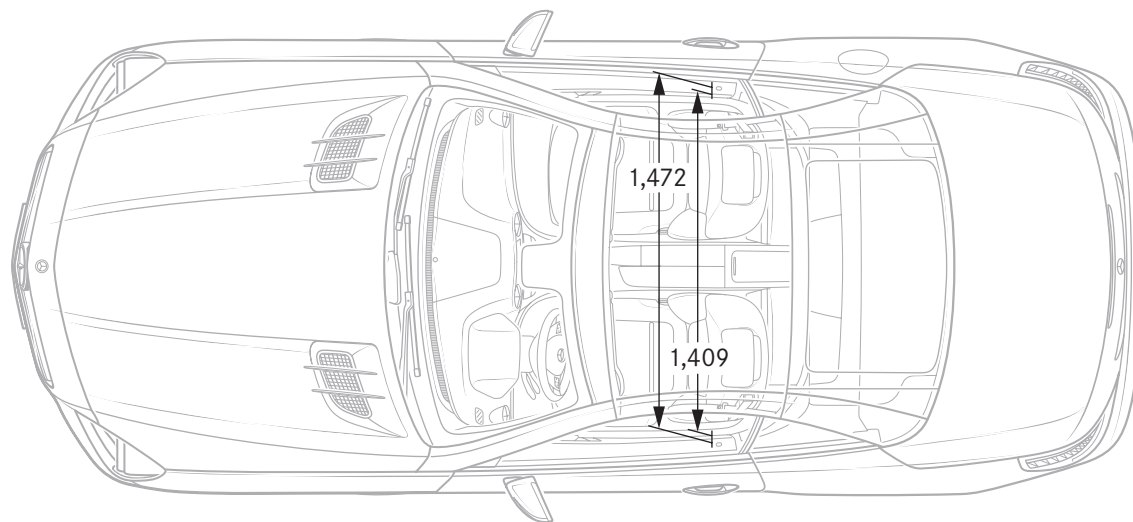
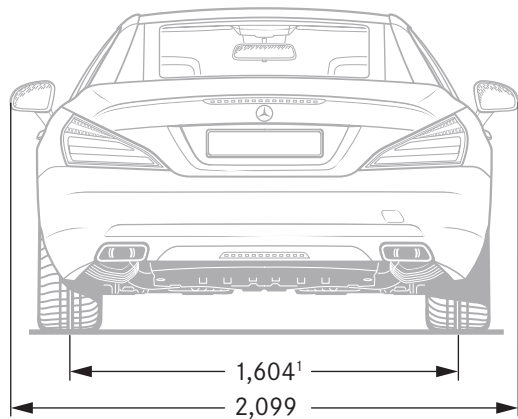
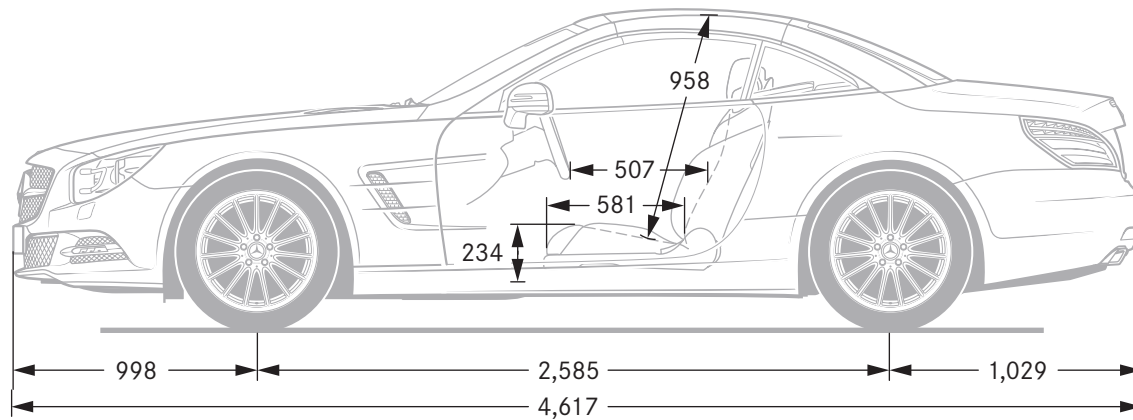
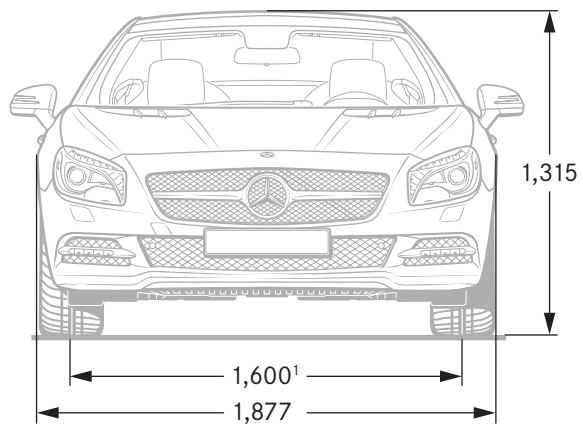

All measurements in millimeters. The dimensions shown are mean values and apply to standard-specification, unladen vehicles ¹When loaded with two persons weighing 68 kg each

Technical data

PETROL ENGINES	SL 350	SL 500
No. of cylinders/arrangement	6/V	8/V
Total displacement – cc	3,498	4,663
Rated output ¹ – hp (kW) at rpm	306 (225)/6,500	435 (320)/5,250
Rated torque ¹ – Nm at rpm	370/3,500–5,250	700/1,800–3,500
Acceleration 0–62 mph – sec	5.9	4.6
Top speed, approx. – mph	155 ²	155 ²
Fuel consumption ³ – mpg		
Urban	28.5	22.1
Extra-urban	46.3	39.8
Combined	37.7	30.7
CO ₂ emissions, combined ³ – g/km	176	214
EU emissions standard	Euro 5	Euro 5
Fuel tank capacity/reserve (approx.) – l	65/8.0	65/8.0
Boot capacity – l		
Roof closed	504	504
Roof open	364	364
Turning circle – m	11.04	11.04
Kerb weight ⁴ – kg	1,685	1,785
Permissible gross vehicle weight – kg	2,065	2,165

¹Figures according to Directive 80/1269/EEC in the currently applicable version

²Electronically limited

³The figures shown were obtained in accordance with the prescribed measuring process (Directive 80/1268/EEC in the currently applicable version). The figures are not based on an individual model and do not constitute part of the product offer; they are provided solely for purposes of comparison between different vehicle models

⁴Figures according to Directive 92/21/EC, version 95/48/EC (kerb weight with fuel tank 90% full, driver, 68 kg, and luggage, 7 kg) for standard-specification vehicles. Optional extras and accessories will generally increase this figure and reduce the payload capacity accordingly

Take-back of end-of-life vehicles. Coming full circle. At the end of its long life, you can return your SL-Class to us for environment-friendly disposal in accordance with the EC End-of-Life Vehicle Directive! But that day lies a long way off.

¹Applies in accordance with national regulations to vehicles up to 3.5 t permissible gross weight. The SL-Class has met the statutory regulations governing the suitability of the vehicles' design for reuse and recycling for a number of years now. A network of vehicle take-back depots and dismantlers has been established which will process your vehicle in an environment-friendly manner. The ways in which both vehicles and parts can be recovered are subject to ongoing development and improvement. Consequently, the SL-Class will be able to comply with any future increases in the recycling quota within the stipulated time limits. For further information, please go to www.mercedes-benz.co.uk or call 0808 156 6606.

Please note: changes may have been made to the products since this brochure went to press (25.07.2011). The manufacturer reserves the right to make changes to the design, form, colour and specification during the delivery period, provided these changes, while taking into account the interests of the vendor, can be deemed reasonable with respect to the purchaser. Where the vendor or the manufacturer uses symbols or numbers to describe an order or the subject of an order, no rights may be derived solely from these. The illustrations may show accessories and items of optional equipment which are not part of standard specification. Colours may differ slightly from those shown in the brochure, owing to the limitations of the printing process. This brochure has been compiled by Daimler AG of Germany and is distributed internationally. It provides a general indication of the range of models, features, optional extras and/or colours available in various countries. Some of the models, features, optional extras and/or colours shown may not be available in your country or may only be available in a different specification. Additionally some models, features, optional extras and/or colours may only be available in combination with others. For current and more specific information in relation to the range of models, features, optional extras and/or colours available in your country, and their pricing, you should contact your nearest authorised Mercedes-Benz Retailer. www.mercedes-benz.co.uk