



# The new Atego

Distribution transportation. 6.5 – 16 tonnes



Mercedes-Benz  
Trucks you can trust

The new Atego.  
The new benchmark  
in distribution transportation

# Contents

<b>Value</b>	<b>6 – 7</b>
<b>Dedication</b>	<b>8 – 17</b>
Cab, equipment	10 – 13
Engines, transmissions	14 – 15
Driving comfort, body-mounting ability	16 – 17
<b>Efficiency</b>	<b>18 – 27</b>
Fuel consumption	20 – 21
Repair, maintenance	22 – 23
Services	24 – 27
<b>Technical data</b>	<b>28 – 31</b>





# Taking established excellence to a new level.

## The new Atego

**Value.** Right from the first encounter – and for many thousands of kilometres to come: the new Atego is a winner on all fronts. Because it embodies the outstanding attributes of its predecessor and achieves the feat of further improving on these strengths.

Such attributes include high quality, outstanding reliability and durability, for example. A wealth of new features and technical measures additionally endow the new Atego with a standard of efficiency and practicality that make an equally fine impression in daily operation and in your accounts. The further enhanced body-mounting ability and the increased environmental compatibility are additional merits that underscore the value of the new Atego and make it the vehicle of choice for light distribution work.

This special value and quality is manifested in the new, cutting-edge and particularly fuel-efficient 4- and 6-cylinder in-line engines, for example. With these engines, the Atego already complies in particularly economical style with the

Euro VI emissions standard which will become mandatory in 2014. The optional Mercedes PowerShift 3 automated gearshift system, effortless handling and optionally available attractive aluminium wheels are additional features that set the new Atego apart. The new interior design concept also highlights the vehicle's enhanced value. As illustrated by the newly designed, ergonomic driver's workplace, for example, which comes in three different cockpit variants. Features such as the optional leather steering wheel and the optionally available comfort suspension seat add a defining finishing touch. The new Atego provides you with a truck that ticks all the boxes in light distribution operations. At the same time, it can also play a crucial role in helping to make your company even more profitable in this sector. Climb aboard!



**New exterior design.** The Atego's newly designed, striking exterior makes its mark in distinctive style: from the bumper via the standard-fit daytime running lamps and following the sleek aerodynamic lines up to the roof – everything is new, seamlessly accomplished and typically Mercedes-Benz





# Tailor-made – for working in light distribution operations

A newly designed, even more ergonomic driver's workplace offering yet more comfort ensures that you're all set for light distribution operations. You will also be delighted by the new, high-torque Euro VI engines which feature as standard and the Atego's effortlessly assured handling.

**Dedication.** The new Atego represents a new truck generation boasting a whole array of new features – all designed to make lighter work of distribution transport operations.

Apart from lending the Atego a striking, distinctive appearance, the newly designed cabs come up trumps on the inside, too. To enable the Atego to be tailored more specifically to the particular type of work involved, it is available with three different cockpit variants which provide for a high standard of driving comfort and ergonomic quality in conjunction with the new instrument cluster, the new multifunction steering wheel and the comfortable seats. All the controls and stowage facilities are positioned for maximum convenience and enable simple handling inside the vehicle.

The many new operational strengths of the Atego also become immediately apparent as soon as the vehicle is set in motion. Highlights here include the new steering, the newly developed rear axle guide, the optionally fitted Mercedes PowerShift 3 automated gearshift system and the updated, yet more fuel-efficient 4- and 6-cylinder in-line engines. Mindful that distribution transport operations involve many different types of applications for vehicles, the new Atego also offers a level of body-mounting ability designed to cover virtually any need. This is ensured by a whole range of developments, including a new electrics and electronics concept and a highly diverse scope of factory-fitted pre-installations. All in all, this means that with the new Atego you are better prepared for daily operations in distribution transportation than ever before. And the Atego is designed to ensure that it stays that way.

<sup>1)</sup> Availability dependent on gross vehicle weight



**Convenient, low entrance.** The low entrance is typical of the way in which the new Atego accommodates operational needs: one or two steps<sup>1)</sup>, doors that open particularly wide and grab handles on either side afford easy, safe and convenient access to the cab



# Tailored to operational needs for a more motivating and enjoyable working environment. The new Atego cabs

The cabs for the new Atego are designed through and through to meet operational needs in light distribution transport. With high-end ergonomics, a high standard of driving comfort and convenience and a wealth of practical details.

**Cab variants.** With a total of four cabs measuring 2295 mm in width, the new Atego offers excellent all-round visibility and straightforward, precise handling in all typical distribution transport operations up to 16 tonnes. From the convenient, low entrance to the three different cockpit variants, the new Atego has just what it takes to ensure an efficient and pleasant workplace.

**S cab ClassicSpace.** The newly designed S cab ClassicSpace and the S cab ClassicSpace with rear panel extended by 180 mm boast compact exterior dimensions and ample space inside. The new interior design, the high-quality workmanship and a host of practical details and features provide for a particularly high standard of ergonomics and driving comfort.

**L cab ClassicSpace.** The L cab ClassicSpace is 2295 mm wide and 2250 mm long, with an interior height of 1510 mm. The L cab ClassicSpace is more spacious and offers more stowage space than the S cab. It comes with a comfort bunk measuring 2095 mm in length by 680 mm in width as



**S cab ClassicSpace.** Measuring 2295 mm in width and 1650 mm in length, the S cab ClassicSpace combines a comfortable workplace with a high level of visibility and full body length. Just the set-up to tackle narrow alleys and backyards with ease



**L cab BigSpace.** With a high roof and measuring 2295 mm in width and 2250 mm in length, the L cab BigSpace offers great freedom of movement and plenty of stowage space. It is ideal for operations involving frequent overnight stays on board



standard, making it suitable for applications that last more than one day. Only the L cab BigSpace offers even greater comfort.

**L cab BigSpace.** 2295 mm wide and with an interior height of 1910 mm, the L cab BigSpace is ideal for comfort-oriented use involving frequent overnight stays on board. The cab's defining feature is its spaciousness, including a bottom bunk measuring 2095 mm in length by 680 mm in width as standard and plenty of stowage space under the comfort bunk and over the windscreen. A second, top bunk is optionally available. Numerous options are available for all of the Atego's cabs, to adapt the working, driving and living comfort to your individual needs and wishes.

**Cockpit variants.** The three different cockpit variants for the new Atego are also tailored closely to operational needs. The Atego comes with the classic cockpit as standard. Optionally, the Atego is available with the standard cockpit or the comfort cockpit.

Defining features of all three cockpit variants are the ergonomic arrangement of all the controls and practical stowage facilities. From the cup holders within the driver's reach to the standard-fit power socket – everything is there to make lighter work of distribution transport operations. The new colour design, the pleasant feel of the interior materials and the high-quality workmanship are additional attributes which make driving and working with the Atego an even more pleasurable experience.



**Classic cockpit.** The standard, classic cockpit of the new Atego is ideally designed for distribution transport operations. Everything is arranged ergonomically and within the driver's reach. The optionally available Mercedes PowerShift 3 automated gearshift system is operated conveniently via the right-hand steering column lever, for example. This means more space to relax during breaks and ensures more convenient through-cab access to the co-driver's side. On Ategos with manual transmissions, the gearshift lever is now integrated in the dashboard



**Comfort cockpit.** The optionally available comfort cockpit offers even more stowage facilities and storage space thanks to its extended stowage shelf below the instrument panel. The comfort cockpit is available for certain model and equipment configurations

**The Atego as a workplace.** The workplace in the Atego boasts an ergonomic overall layout and stowage facilities and controls arranged in exemplary manner to create a relaxed work environment conducive to good concentration. Once seated, the driver will immediately notice the new instrument cluster with 10.4 cm TFT colour display, which offers fast and detailed information on all the vehicle's functions, clearly legible on the anti-dazzle display. The new on-board computer with integrated departure check gets things up and running efficiently at the beginning of the working day. An instrument cluster with 12.7 cm TFT colour

display, video function and pre-installation for a reversing camera<sup>1)</sup> is optionally available. For added convenience, numerous vehicle functions can be controlled via the new multifunction steering wheel, which is optionally available in leather. The optionally available Mercedes PowerShift 3 automated gearshift system can be operated conveniently via the right-hand steering column lever for easy handling. The clothes rail which is fitted as standard on the cab's rear panel and optional features such as the multifunction stowage facility which also serves as a table on the engine tunnel add a further touch of utility value.

seat is standard and the co-driver's seat is fixed. There is the option of a suspension seat for the co-driver, as well as comfort suspension seats and climatized suspension seats for both the driver and the co-driver. Apart from a broad choice of individual setting options and the armrests<sup>2)</sup>, a defining feature of these seats is their simple, intuitive mode of operation.

**New generation of bunks.** The L cab ClassicSpace and the L cab BigSpace are fitted with the new bottom comfort bunk as standard. Measuring 2095 mm in length and 680 mm in width, this bunk features a comfortable seven-zone cold-foam mattress for excellent relaxation and comfortable sleeping. A top comfort bunk on a par with the bottom bunk is optionally available for the L cab BigSpace. This bunk offers a levelling function enabling swift adjustment when the vehicle is parked on an uneven surface, to ensure a comfortable lying position.

**Comfortable seats.** The seats are another crucial comfort feature in the driver's workplace. For vehicles below 11 tonnes the fixed driver's and co-driver's seat is standard. Optionally available are suspension seats, comfort suspension seats and climatized suspension seats for both the driver and co-driver. For vehicles above 11 tonnes the driver's suspension



**High seating comfort.** The comfort suspension seat is optionally available for the driver's and co-driver's side, boasting folding armrests<sup>2)</sup> and integrated belt height adjustment along with a host of other comfort features



**Multifunction steering wheel.** The standard-fit multifunction steering wheel makes light work of various functions: apart from the radio and telephone, the cruise control can now also be operated via the steering wheel. Many other vehicle functions and diverse settings can also be controlled in the new instrument cluster



**12.7 cm TFT colour display.** The new Atego is optionally available with an instrument cluster incorporating a 12.7 cm TFT colour display and video function. The images from an optionally<sup>1)</sup> available reversing camera can be viewed on this display, for enhanced safety during manoeuvring, for example





**New radios.** For good entertainment the Atego can be fitted with a radio, a CD radio, a CD radio with Bluetooth connection or the CD radio Comfort with Bluetooth. All radios are provided with a USB interface and an Aux/In interface for connecting external devices



**Multimedia communications.** A universal pre-installation is optionally available for the simple integration of mobile phones, MP3 players and commercially available navigation systems, for example



**Multifunction stowage facility.** The multifunction stowage facility which is optionally available for the engine tunnel does full justice to its name. Along with various stowage options, the facility also incorporates a practical and straightforward table function that proves its worth both during transport operations and in breaks from work



**Manual transmission.** The Atego is fitted with a manual transmission featuring power-assisted gear shifting as standard. The benefits of this manual transmission include excellent ergonomics and highly precise shifting, while only minimal effort is required by the driver to change gear



### Advantages at a glance

- Four different cabs tailored specifically to operational needs
- New interior design with ergonomic workplace
- Three cockpit variants tailored to different types of deployment
- Optional Mercedes PowerShift 3 automated gearshift system for better handling
- New, clearly legible instrument cluster with 10.4 cm TFT colour display and ergonomically positioned controls and stowage facilities
- Intuitive multifunction steering wheel as standard
- Optional instrument cluster with 12.7 cm TFT colour display, video function and pre-installation for a backup camera<sup>1)</sup>
- Various radios and multimedia interface optionally available
- High seating comfort, optional comfort suspension seat or climatized suspension seat
- On-board computer with departure check

<sup>1)</sup> A reversing camera is available from Mercedes-Benz Accessories

<sup>2)</sup> Only available in conjunction with automated gearshift system



# Your trusty partner for a working lifetime

New 4- and 6-cylinder engines which generate more power on less fuel.

**High-torque Euro VI engines.** Powerful, reliable, economical – with the new, high-torque 4- and 6-cylinder in-line engines, the new Atego is ideally equipped for light distribution transport operations. The 4-cylinder engines with a displacement of 5.1 l generate up to **170 kW** (231 hp) of power and maximum torque of 900 Nm. The 7.7-litre 6-cylinder engines offer an output of up to **220 kW** (299 hp) and 1200 Nm of torque.

The standard-fit Euro VI engines operate at an injection pressure of up to 2400 bar. This helps them to generate the necessary power instantaneously – in perfect sync with the movements of your foot on the accelerator pedal. Additional benefits offered by the new engines include spontaneous response and very smooth running. The new engine brake<sup>1)</sup> with up to **235 kW** of braking power also provides for a high standard of safety. A high-performance engine braking system offering up to **300 kW** of braking power is optionally available. A further option is the fuel preheating system to ensure that everything continues to run absolutely smoothly even at extremely low temperatures.

**Shifting gear the easy way.** The new Atego is fitted with a manual transmission as standard featuring power-assisted gear shifting, which is operated via the shift lever in the instrument panel. The benefits of this option include excellent ergonomics, highly precise shifting and minimal shifting effort.

For particularly smooth gear changing and excellent driving comfort, the Mercedes PowerShift 3 automated gearshift system is available as an option. Mercedes PowerShift 3 boasts a precision gearshift sensor system and an intelligent shift strategy which provides for gear selection tailored precisely to the given driving and load situation. It also enables particularly swift gear-changing, with substantially shorter shift times than the Telligent® automatic gearshift system.

The Atego comes with the economy driving programme as standard; the power driving programme is optionally available. The driving programmes incorporate different driving modes and auxiliary functions to enable a fuel-efficient driving style in keeping with the given driving situation. EcoRoll mode in the economy driving programme helps to reduce fuel



**6-cylinder engines.** The Atego's new 6-cylinder in-line engines combine high output and high torque with low fuel consumption. A further advantage that pays in distribution transport is their high level of reliability



consumption, for example. Various auxiliary functions make even easier work of distribution transport with Mercedes PowerShift 3. The standard crawl function is a boon when moving off on slopes, for example. And direct shifting from 1 to R makes manoeuvring simpler.

**Transmission.** The Atego is available with a choice of 6-, 8- or 9-speed transmission, enabling the vehicle to be tailored particularly effectively to its intended field of deployment. In conjunction with the perfectly matched drive axles and the broad choice of gear ratio variants, the new Atego offers a highly responsive, high-torque, economical drive for every type of task encountered in distribution transportation. And this ultimately makes driving the vehicle a more comfortable and pleasurable experience.

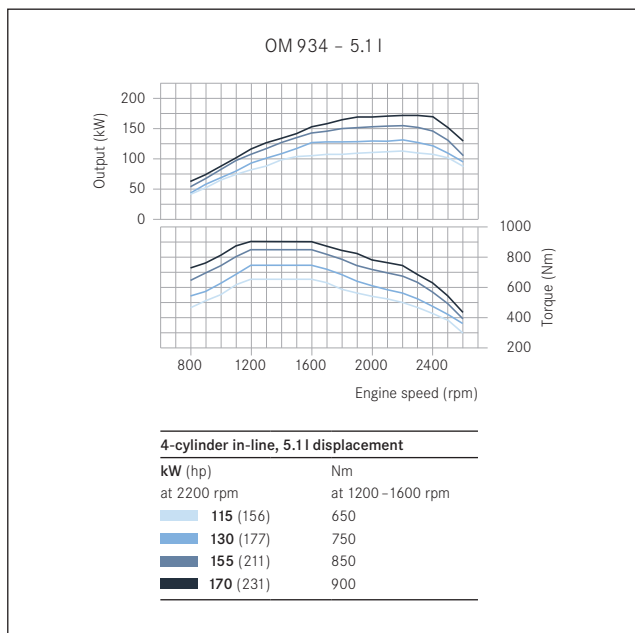

**Reduced displacement, increased performance.** With an output of up to **170 kW** (231 hp) and maximum torque of 900 Nm, the Atego's new 4-cylinder in-line engines boast performance data which have been the reserve of 6-cylinder engines to date

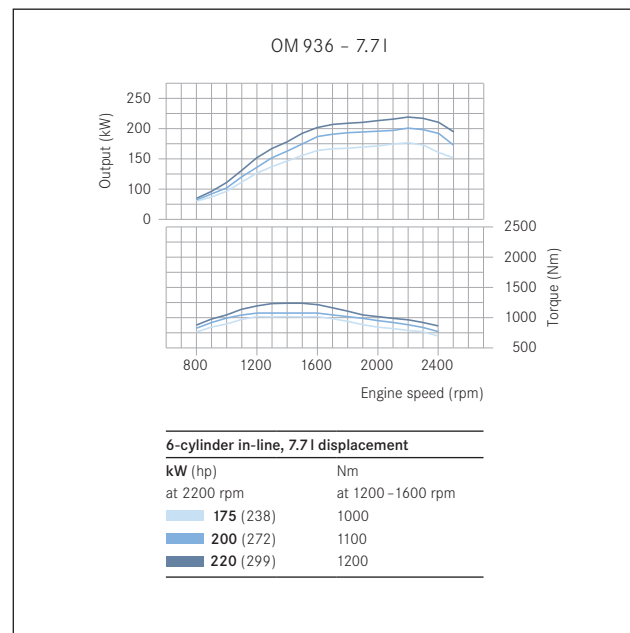

**More power, more torque.** With an output of up to **220 kW** (299 hp) and maximum torque of 1200 Nm, the new 6-cylinder in-line engines provide just the power you need for your distribution transport operations

**i Advantages at a glance**

- More fuel-efficient, reliable 4- and 6-cylinder in-line engines with high torque at low engine speeds
- BlueTec® 6 as standard
- Two displacement classes, seven power variants from 115 kW (156 hp) to 220 kW (299 hp)
- Optionally available Mercedes PowerShift 3 automated gearshift with economy driving programme plus manually selectable driving modes and auxiliary functions
- Choice of 6-, 8- and 9-speed transmissions for drive systems geared specifically to the intended area of application

<sup>1)</sup> Standard for permissible GVW of 9 t and over



# The new Atego – the ultimate smooth operator on the distribution rounds

The new Atego has a whole range of practical advantages in store – more efficient working with the vehicle, markedly improved handling and enhanced body-mounting ability, for example. Ideally, you should put the literature aside and try the vehicle out for yourself. Then you'll know just what we mean. And just what a treat the Atego is to work with.

**Driving comfort.** From the standard-fit ESP Electronic Stability Program to the new 4-point cab suspension which also features as standard to reduce pitching and rolling movements of the cab, the new Atego offers markedly improved handling and a yet more self-assured feeling behind the wheel. The new steering, the new rear axle guide and the suspension variants tailored to different types of application are also instrumental to this improved standard of driving comfort. The new steering gear provides for substantially enhanced steering precision, improved straight-line stability and high directional stability during braking, for example. The new rear axle guide<sup>1)</sup> provides for reduced roll understeer. This has been made possible on Ategos with steel suspension by optimum positioning of the pivot points on the rear springs, and on air-sprung Ategos by optimising the pivot point on the parabolic control arm. The upshot is an excellent standard of handling which will delight you from your very first trip in the new Atego.



**More precise steering.** The Atego's new steering provides for simple, exact handling during manoeuvring and for reliable straight-line stability and high directional stability at high speeds. A further advantage of the new steering is enhanced steering precision, requiring less corrective action on the part of the driver

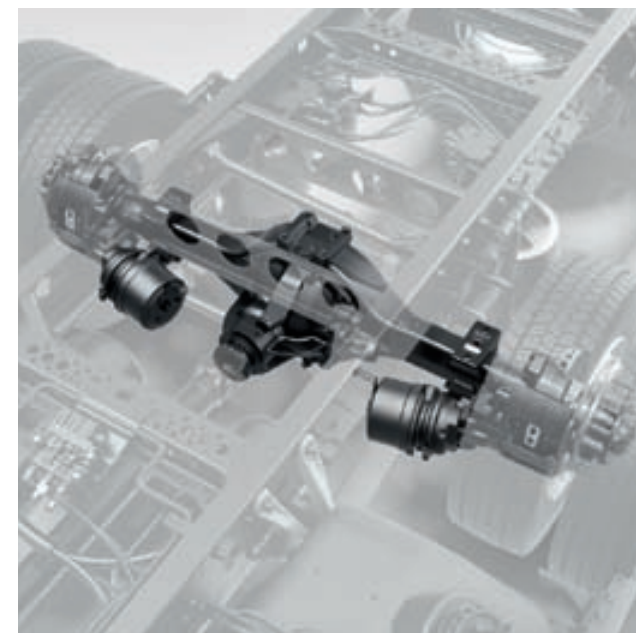

**Rear axle guide.** For superior handling, air-sprung Ategos up to 10.5 t and 12 t with low frame as well as all Ategos with steel suspension are fitted with the new rear axle guide, featuring optimum positioning of the pivot points on the rear spring (steel suspension) and on the parabolic control arm (air suspension) to reduce roll understeer



### Enhanced body-mounting ability, improved handling.

The new Atego supports you more effectively than ever in your daily distribution tasks. The body-mounting ability has been further enhanced by the introduction of the parameterisable special module, for example, which simplifies the connection, integration and subsequent operation of mounted bodies. A whole range of measures, from the optimised positioning of all components on the frame to a wealth of factory-fitted pre-installations, additionally helps to ensure that the Atego is back in your hands and back in operation more quickly.

The new Atego additionally features an electrics and electronics concept which provides you with a wealth of practical and comfort-enhancing functions as standard. The extended scope of features includes convenient brief turn signals, for example, a warning tone for parking brake and lights, cruise control operation using the buttons on the multifunction steering wheel and “follow me home” lights. In short, a host of functions to make handling simpler and work more pleasant.

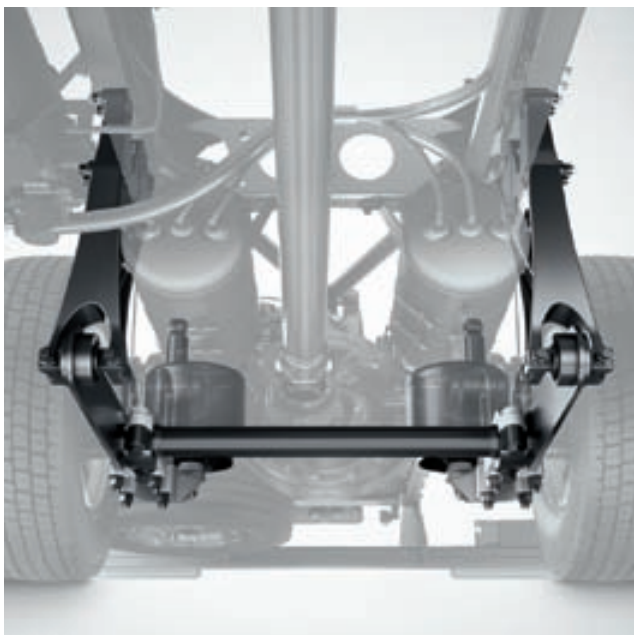

**Suspension variants.** The new Atego is fitted as standard with weight-optimised single- or multi-leaf parabolic springs. For enhanced ride and suspension comfort a combination of steel and air suspension is available. Full air suspension is possible for Ategos with a permissible gross vehicle weight of 12 t and over



**Parameterisable special module.** The parameterisable special module enables the tailor-made programming of complex bodies and power take-offs. It also provides for perfect data processing and the exchange of information between vehicle and body



#### Advantages at a glance

- Superior ride comfort, enhanced body-mounting ability and more efficient handling
- Electronic Stability Program (ESP) as standard
- New 4-point cab suspension as standard
- New, enhanced rear axle guide as standard<sup>1)</sup>
- Optional air suspension for high ride comfort and gentle transportation of loads
- Improved connection facilities and optimised body integration
- Cost-cutting factory-fitted pre-installations
- Improved handling through practical details and features such as brief turn signals, lights-on buzzer, operation of cruise control via steering wheel buttons

<sup>1)</sup> For 10.5 t and 12 t with low frame as well as for all Ategos with steel suspension









# On board every trip: that extra portion of efficiency

The new Atego introduces an array of technical measures designed to keep distribution transport operations particularly economical in future. This means low fuel consumption. And low overall operating costs – throughout the vehicle's useful life.

**Efficiency.** To make your light distribution transport operations even more cost-effective and profitable, the new Atego has been designed with a special emphasis on economy.

Its new engines, which already comply with the Euro VI emissions standard scheduled for introduction in 2014, are a case in point. These fuel-efficient 4- and 6-cylinder in-line engines combine particularly low fuel consumption with a high level of reliability. Other features contributing towards low fuel consumption are fuel-efficient auxiliary consumers, optimised powertrain configurations and the optionally available Mercedes PowerShift 3 automated gearshift system. FleetBoard® EcoSupport is additionally integrated in the instrument cluster as standard to support the driver in maintaining a fuel-efficient style of driving. Longer maintenance intervals, the long service lives of many components and the Atego's repair- and maintenance-friendly design also help to keep overall operating costs low.

Another attribute of the new Atego that helps to cut costs from the outset is its further enhanced body-mounting ability. The standard-fit electronic brake system with ABS, acceleration skid control and hill holder provides for a high level of efficiency during braking, too. Beyond this standard equipment, optionally available efficiency-enhancing services such as FleetBoard® also help to boost economic efficiency in distribution transport operations. As you can see, we spare no effort to ensure that the new Atego offers you the added efficiency that is vital to you today and will remain so in the future.



**Euro VI as standard.** The Atego is streets ahead when it comes to emission standards, too. Particularly efficient, cutting-edge technology in the guise of BlueTec® 6 and the standard-fit particulate filter will keep you exempt from the vehicle bans which are looming in many inner-city areas

# Top on economy – and a rare sight at the filling station

More mileage from your tank – the new Atego is particularly fuel-efficient. With Euro VI engines as standard, offering enhanced performance combined with lower fuel consumption. And with a host of technical innovations designed to further reduce your fuel bill.

**Future viability with Euro VI.** The Atego's new 4- and 6-cylinder in-line engines already comply with the Euro VI emissions standard in particularly economical style – and the standard-fit diesel particulate filter ensures that the new Atego will remain exempt from the vehicle bans which are looming in many inner-city areas. The high environmental compatibility of the cutting-edge in-line engines stems from features such as highly efficient fuel combustion with a low level of soot particles, cooled exhaust gas recirculation and BlueTec® 6 technology. As a result of these developments, in addition to its low fuel consumption and the attendant low CO<sub>2</sub> emissions, particulate and nitrogen oxide emissions from the new Atego are also down by around 90% in comparison to its predecessor. This benefits both the environment and your company – in attaining your self-defined environmental targets, for example. And by boosting your competitive strength. From the very first day until far into the future.

**Low fuel consumption.** For even more efficient distribution transport operations, we have provided the Atego with a wealth of technical innovations, all centring on the common aim of reduced fuel consumption. The new Atego achieves fuel savings of up to 5%<sup>1)</sup> in comparison to its predecessor. This fuel economy is attributable first and foremost to the new 4- and 6-cylinder in-line engines. The high-pressure injection system based on common rail technology and operating at an injection pressure of up to 2400 bar provides for particularly efficient combustion, for example. Energy-optimised auxiliary consumers such as the new, electrically controlled viscous fan clutch and the controlled air compressor result in additional fuel savings. The optimised AdBlue® injection process, which now operates without compressed air, also increases the efficiency of the new Atego. Another notable feature in this connection is the standard-fit FleetBoard® EcoSupport function which provides the driver with a steady output of tips on how to maintain an economical style of driving. Beyond these standard features, the optional FleetBoard® services can play a key role in helping to further reduce fuel consumption.



**8-speed automatic transmission.** In addition to three different 6-speed automatic transmissions, the Atego is now also available with a new 8-speed automatic transmission<sup>2)</sup>

**Efficient power transmission.** A selection of transmission variants and a range of fuel-efficient hypoid axles with different gear ratios provide for efficient power transmission from engine to road.

The optionally available Mercedes PowerShift 3 automated gearshift system also offers increased efficiency: with an optimised shift strategy and driving modes tailored to operational requirements, it enables an effortless and foresighted style of driving in practically any situation encountered in distribution transportation.

**Weight optimisation.** The new Atego features a whole array of weight-optimising measures that help to largely offset the additional weight resulting from the Euro VI technology. These include the steel suspension<sup>3)</sup> and the new, weight-reduced side guards<sup>4)</sup>, for example.

**Sophisticated aerodynamics.** The Atego's new design has been optimised in countless hours in the wind tunnel. From the bumper through the corner panels to the roof – everything contributes to reduced drag in the interests of lower fuel consumption and lower costs.

Driving programme	Power			
	Economy			
Driving mode	Economy	Standard	Manual	Power
	No kickdown possible	Kickdown possible	No kickdown possible	Kickdown possible
	EcoRoll cannot be deactivated	EcoRoll can be deactivated	EcoRoll deactivated	EcoRoll deactivated
	Top speed 85 km/h	Top speed 89.8 km/h	Top speed 89.8 km/h	Top speed 89.8 km/h

**Driving programmes geared to operational needs.** The optionally available Mercedes PowerShift 3 comes with the economy driving programme as standard. This programme incorporates various driving modes which are designed to enable precise, straightforward handling and fuel-efficient driving in virtually any driving situation



**FleetBoard® EcoSupport.** While the driver is at the wheel, the standard-fit FleetBoard® EcoSupport system provides him with a steady output of tips on how to further optimise his driving style in the interests of reduced fuel consumption and wear

**i Advantages at a glance**

- Efficient Euro VI engines with BlueTec® 6 technology
- High-pressure injection at up to 2400 bar
- Early compliance with Euro VI as standard
- Energy-optimised auxiliary consumers
- More fuel-efficient AdBlue® injection
- Mercedes PowerShift 3 automated gearshift with driving modes tailored to operational requirements if selected
- Powertrain configurations designed to optimise fuel consumption
- Optimised aerodynamics for reduced drag
- FleetBoard® EcoSupport as standard for fuel-efficient driving

<sup>1)</sup> Fuel savings are slightly lower in urban traffic

<sup>2)</sup> For Ategos from 175 kW (238 hp) to 220 kW (299 hp)

<sup>3)</sup> Single-leaf steel springs on Ategos with perm. GVW of 7.5 t and 8 t

<sup>4)</sup> Ategos up to 10.5 t perm. GVW





# More mileage for less – and that goes for maintenance and repairs, too

Low costs as standard – thanks to the Atego’s robust, repair- and maintenance-friendly design, the extended service life of many components and long maintenance intervals geared to actual use of the vehicle. Plus attractive services from FleetBoard® for even more profitable operations right from day one.

## **Maintenance intervals geared to actual use of the vehicle.**

Particularly long maintenance intervals based on the vehicle’s actual level of wear and tear mean that the new Atego spends more time in active service and makes less visits to the workshop. Along with the increased service life of many components, a crucial factor here is the new, dynamic maintenance computer. This computer continuously monitors service products and fluids and wearing parts, such as the engine oil and brake linings, and records their precise conditions. It alerts the driver in good time when the engine oil needs to be changed or the brake linings require replacing, for example. This enables all service fluids and wearing parts to be used to the full. In addition, servicing can be planned over the long term and necessary items of maintenance work can be carried out together. This means that maintenance work takes place when it is actually necessary – neither too early nor too late. This reduces downtimes and saves money. The Atego also performs a departure check each time it is started up – notifying the driver only when action is necessary.

## **Low repair and maintenance costs.**

There are many reasons why repair and maintenance work on the new Atego can be carried out particularly quickly and practically as cost-effectively as on its predecessor. From the outset, special attention was devoted to ensuring that all components are particularly robust and to minimising the necessary scope of maintenance and repairs. This approach has resulted in extended oil change intervals for transmissions and rear axles, reduced oil consumption and a diesel particulate filter which can be serviced when the engine oil becomes due for changing in accordance with the intensity of vehicle use. For maximum cost efficiency, the filter can be replaced when necessary with another, ready-serviced filter. This reduces downtimes and saves money. Another example is the optionally available maintenance- and wear-free permanent-magnet retarder, which enhances safety, reduces wear on the service brake and can lower fuel consumption. This all contributes to lower repair and maintenance costs and increased efficiency in distribution transport operations.



**LED technology.** Apart from highlighting the Atego’s distinctive design, the optionally available LED daytime running lamps also cut costs, as the LEDs are designed to last throughout the Atego’s useful life. LED side marker lamps and tail lamps are optionally available

**Truck Maintenance Management.** Mercedes-Benz Truck Maintenance Management is optionally available in conjunction with FleetBoard®. Maintenance and wear data are available from the vehicle for you to pass to your chosen service partner on a regular basis – with no need for the vehicles to be taken to the workshop. The advantage of this system is that maintenance and replacement work are only carried out when they are actually necessary. This enables maintenance costs to be optimised and vehicle availability to be increased.



**Dynamic maintenance computer.** The new Atego is equipped with a dynamic maintenance computer. “Dynamic” means that maintenance intervals are now calculated on the basis of actual wear, rather than driven mileage. This enables service products and fluids to be used to the full and maintenance work to be combined in an effective manner



**FleetBoard® TiiRec computer.** The optionally available FleetBoard® TiiRec computer continuously records relevant vehicle data which can be used as a basis for assessing the driving performance with the aid of FleetBoard® Performance Analysis and for Truck Maintenance Management, for example



#### Advantages at a glance

- Dynamic maintenance computer for up to 120,000 km, depending on intensity of use of the vehicle
- Repair- and maintenance-friendly design
- Designed for low maintenance and repair costs from the outset
- Extended service life of many parts and components results in low costs
- Optional Truck Maintenance Management in conjunction with FleetBoard® for optimised maintenance costs and reduced downtime



# Service – the full works for your hard-working Atego

A dense network of workshops with extended opening hours, Mercedes-Benz Service24h, FleetBoard<sup>®</sup>, Mercedes-Benz Financial Services and a large team of specialists on hand to assist you all add up to greater efficiency and availability for your vehicles employed in light distribution transport operations – the full works for your hard-working Atego.

**Mercedes-Benz Service.** Around 1800 Mercedes-Benz Service Centres are available throughout Europe for all types of repair and maintenance work. Many of these centres remain open until 10 p.m. or even midnight. Mercedes-Benz Service24h is available round the clock to provide swift assistance in the event of a breakdown or accident. Just give us a call, and we'll attend to the rest. Our trained staff and an efficient logistics system for parts furthermore enable particularly short repair times to ensure that your new Atego is back in operation as quickly as possible. Fixed-price offers which clarify beforehand what costs will arise and how long the repair or maintenance work will take also simplify the repair or maintenance process. The use of Mercedes-Benz GenuineParts is another factor which contributes to long service lives while bolstering the performance of your new Atego and helping it to retain its value.



**Mercedes-Benz Service24h.** In the event of a breakdown or accident, a call to the free service hotline<sup>1)</sup> on 00800 5 777 7777 is all it takes for us to organise swift assistance from the nearest garage, anywhere in Europe



**FleetBoard® Vehicle Management.** The optional FleetBoard® system on board your new Atego offers an excellent means of making your distribution transport operations even more profitable. FleetBoard® Vehicle Management promotes a fuel-efficient, wear-reducing style of driving, enables longer maintenance intervals and increases vehicle availability. FleetBoard® Performance Analysis enables objective assessment of the driver's individual style at the wheel, providing the basis for fuel-efficient driving and lasting reductions in fuel consumption. Experience has shown that fuel consumption can be reduced by up to 7% through more economical driving, rising to as much as 10% if FleetBoard® continues to be used. Furthermore, ongoing

support and training with FleetBoard® prevents drivers from slipping back into their old ways and using increased amounts of fuel again. The FleetBoard® EcoSupport system additionally provides the driver with a steady output of tips on how to improve his style of driving. As part of FleetBoard® Vehicle Management, you can also have access to vehicle service information, which reduces your administrative workload and helps to reduce costs and downtimes. Further reductions in costs are possible with additional FleetBoard® services, such as Logistics Management and Time Management.

**FleetBoard® Logistics Management.** FleetBoard® Logistics Management serves to make logistics processes more efficient. The basis of this system is the DispoPilot.guide, which can be installed permanently in the cab and features a screen measuring 185 x 120 x 25.5 mm (w x h x d). This allows order data to be sent to the cab in real time and address data to be transferred directly to the navigation system, for example, enabling trips to be managed in an efficient manner. Plus, you are kept fully up to date with the vehicle, trip and order status at all times. This also helps to maximise the capacity utilisation of your new Atego. A further means of optimising your logistics processes comes in the form of the optional DispoPilot.mobile. In contrast to the DispoPilot.guide it can also be used outside the vehicle, for example for scanning in goods and recording digital signatures.

FleetBoard® Logistics Management can also be reliably integrated into your in-house disposition, inventory control or ERP system, enabling distribution managers to work with your trusted software while at the same time incorporating the full scope of FleetBoard® data.

**FleetBoard® Time Management.** With FleetBoard® Time Management, complying with all the legal regulations regarding the logging of driving times and rest periods practically takes care of itself. This is because driver-card and mass-storage data is recorded at the press of a button or completely automatically from the distribution manager's workstation. This saves money and reduces the amount of administration work. With the FleetBoard® app for the iPhone, iPad and iPod touch, you are kept informed whether trips are going to plan or measures need to be taken at short notice, no matter where you are – even at night if needs be. More information about the advantages of FleetBoard® is also available at [www.fleetboard.com](http://www.fleetboard.com) or directly from your authorised Mercedes-Benz Dealer.



**DispoPilot.guide – the simpler and faster way to your destination.** Following transmission of the order data the delivery or collection addresses can be added straight to the integral navigation system. This ensures that you always find the best route to your destination and thus save fuel while you are out on the road



**FleetBoard® Time Management.** After the driver's card has been inserted into the FleetBoard® vehicle computer, all the data is downloaded from the driver's card to the haulage company at the touch of a button. This saves time, plus all the legal requirements are met

<sup>1)</sup> Calls made on mobile phones may be subject to charges

**Mercedes-Benz Financial Services.** We provide finance you can trust for trucks you can trust. Mercedes-Benz Finance was established in the UK more than 21 years ago and has over 131,000 finance contracts. We offer the only finance designed specifically for Mercedes-Benz vehicles and tailored to all fleet sizes and business sectors in the UK. Approved credit applications are normally processed in as little as 19 minutes and 97% of our customers were either satisfied, very satisfied or completely satisfied. Our experienced Business Managers will work with you to understand your business needs and will provide you with a business solution when funding your vehicles. Our most popular finance product is Mercedes-Benz Contract Hire. With one monthly

payment, Mercedes-Benz Contract Hire can take care of all your fleet needs. We also offer two levels of service contracts with factory trained technicians who only use Mercedes-Benz GenuineParts, keeping you 100% Mercedes-Benz.

**Mercedes-Benz Contract Hire.** Contract Hire can be a great way to reduce the hassle of running a commercial fleet. It requires no capital investment and the vehicle is not shown on your balance sheet. How does Mercedes-Benz Contract Hire work? Instead of owning the vehicle or vehicles, you hire them for a fixed period – typically 3 to 5 years – for a fixed monthly fee.

Because this fee is based on the difference between the initial value of the vehicles and their projected value at the end of the agreement, you repay only a proportion of the vehicle's costs, which can only be good news for your cash flow. With a Contract Hire agreement you avoid any concerns about the future value of your vehicle or selling it on – at the end of your agreement you simply hand it back.

**Mercedes-Benz Agility.** At Mercedes-Benz we offer a range of ways for you to fund the purchase of your new Atego. One of our most flexible finance products is Mercedes-Benz Agility.

How does Mercedes-Benz Agility work? At the start of the agreement your Business Manager will advise you of the Guaranteed Future Value for your truck based on the mileage that you expect to cover during the course of your agreement. This Guaranteed Future Value is equal to the final Optional Purchase Payment – but you don't have to decide whether to make this payment and keep the truck until the end of the agreement. In the meantime, you simply choose how long you want to keep the truck, how much you'd like to pay as an initial deposit and the monthly payments that suit you best. When the agreement comes to an end you can either purchase, return or part-exchange the vehicle.



**Mercedes-Benz Financial Services.** For more profitability and more transparency in your fleet – Mercedes-Benz Financial Services offers you tailor-made solutions which can be individually combined and which ensure that you already know beforehand exactly how much a vehicle is going to cost you: per mile driven and over the entire period of use

**Application Information Centre in Würth.** At the Application Information Centre in Würth there is a permanent display of some 180 complete vehicles fitted with sector-specific body solutions from more than 70 manufacturers at your disposal. All the vehicles and body solutions can be test-driven, tried out and directly compared with each other in real-life conditions.

**DriverTraining.** Mercedes-Benz DriverTraining teaches you how to exploit the potential of the new Atego to the full. In addition, by taking part in Mercedes-Benz DriverTraining, you will be contributing towards your Driver CPC. On request we can carry out the Driver Training at your premises or those of an authorised Mercedes-Benz Dealer near you.



**Mercedes-Benz Financial Services.** An international commercial vehicle finance service and the specialists in Mercedes-Benz Finance



#### Advantages at a glance

- Dense network of workshops with around 1800 Service Centres throughout Europe
- Long workshop opening hours, in some instances until 10 p.m. or midnight
- Mercedes-Benz Service24h – swift assistance round the clock in emergencies via the free service hotline which is available free throughout Europe on<sup>1)</sup> 00800 5 777 7777
- Fixed-price packages for the most important maintenance and repair work with Mercedes-Benz GenuineParts
- Mercedes-Benz Finance for individual leasing and financing solutions
- Comprehensive range of services for added efficiency: e. g. Mercedes-Benz DriverTraining courses, Würth Application Information Centre
- FleetBoard® Vehicle Management for increased economic efficiency
- FleetBoard® Logistics Management for efficient logistics processes
- FleetBoard® Time Management for simple compliance with legal regulations and reduction of documentation work involved
- FleetBoard® app for mobile access to your fleet

<sup>1)</sup> Calls made on mobile phones may be subject to charges





## S cab

### S cab ClassicSpace

Exterior width: 2295 mm  
Exterior length: 1650 mm  
Interior width: 2000 mm  
Interior height: 1510 mm

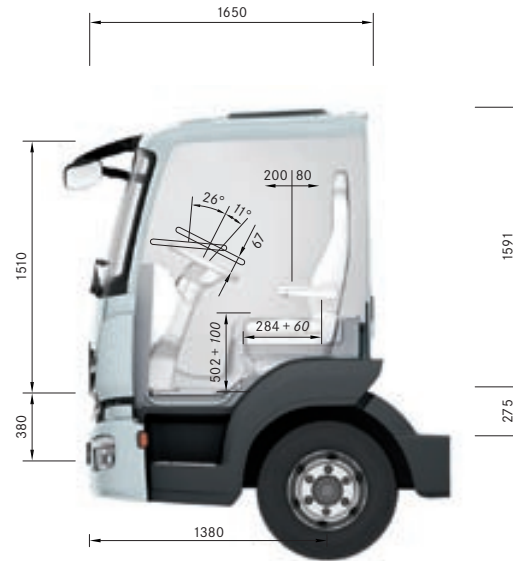

S cab ClassicSpace

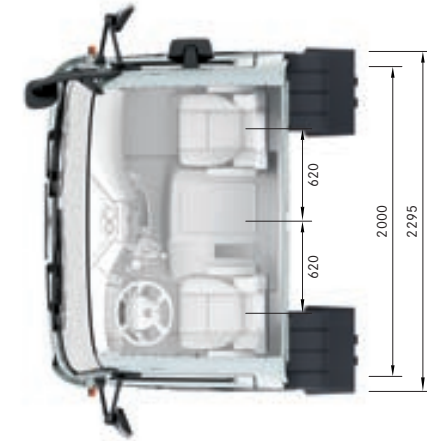

S cab ClassicSpace

### S cab ClassicSpace extended

Exterior width: 2295 mm  
Exterior length: 1830 mm  
Interior width: 2000 mm  
Interior height: 1510 mm

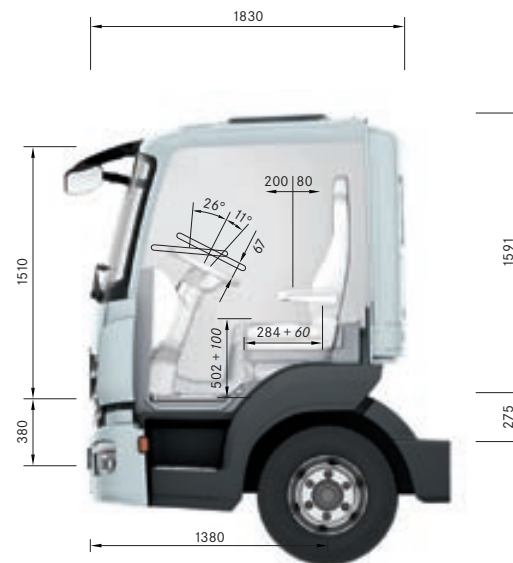

S cab ClassicSpace extended

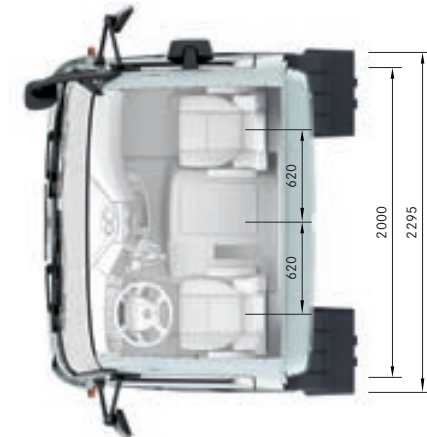

S cab ClassicSpace extended

## L cab

### L cab ClassicSpace

Exterior width: 2295 mm  
 Exterior length: 2250 mm  
 Interior width: 2000 mm  
 Interior height: 1510 mm

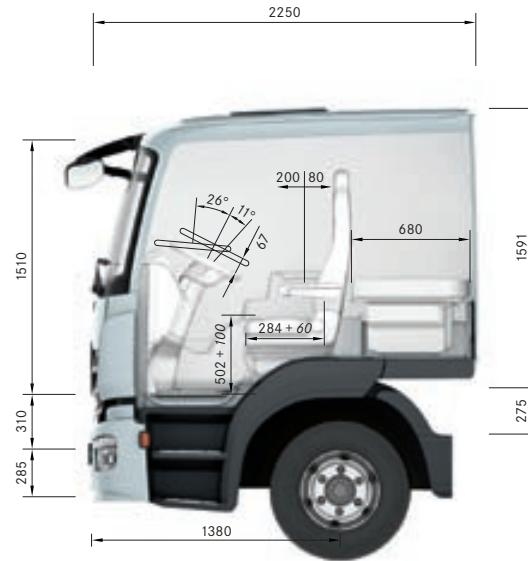

L cab ClassicSpace

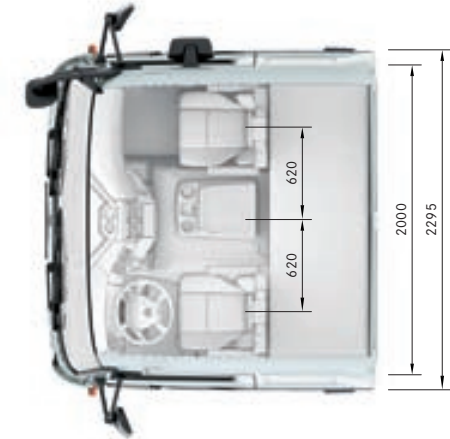

L cab ClassicSpace

### L cab BigSpace

Exterior width: 2295 mm  
 Exterior length: 2250 mm  
 Interior width: 2000 mm  
 Interior height: 1910 mm

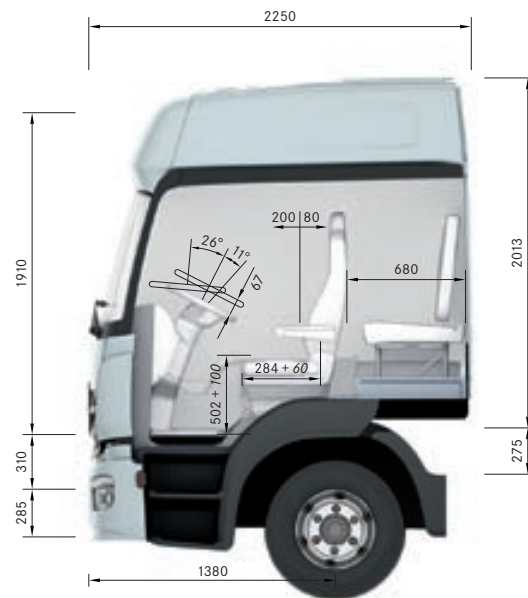



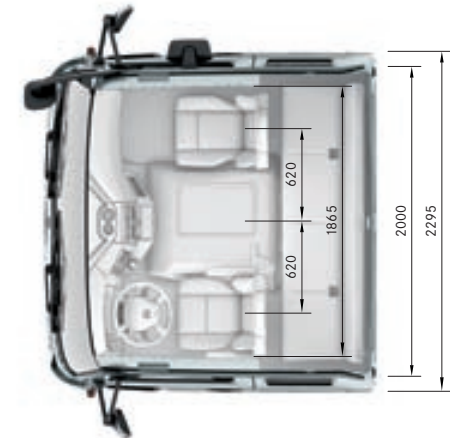









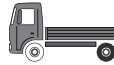

L cab BigSpace



L cab BigSpace



						 <small>also available with low frame</small>		
<b>Gross vehicle weight</b>	6.5	7.49	7.99	9.5	10.5	11.99	13.5	15
<b>Wheel configuration</b>	4 x 2	4 x 2	4 x 2	4 x 2	4 x 2	4 x 2	4 x 2	4 x 2
<b>Suspension</b>	Steel	Steel	Steel	Steel	Steel	Steel	Steel	Steel
<b>Engines</b>								
<b>OM 934</b>								
115 kW (156 hp)	x	x	x	x	-	-	-	-
130 kW (177 hp)	-	x	x	x	x	x	x	x
155 kW (211 hp)	-	x	x	x	x	x	x	x
170 kW (231 hp)	-	x	x	x	x	x	x	x
<b>OM 936</b>								
175 kW (238 hp)	-	-	x	x	x	x	x	x
200 kW (272 hp)	-	-	-	-	-	x <sup>2)</sup>	x	x
220 kW (299 hp)	-	-	-	-	-	x <sup>2)</sup>	x	x
<b>Wheelbase</b>								
3020 mm	x	x	x	x	x	-	-	-
3320 mm	x	x	x	x	x	-	-	-
3560 mm	-	-	-	-	-	x <sup>2)</sup>	x	x
3620 mm	x	x	x	x	x	x <sup>1)</sup>	-	-
4160 mm	-	-	-	-	-	x <sup>2)</sup>	x	x
4220 mm	x	x	x	x	x	x <sup>1)</sup>	-	-
4760 mm	-	-	-	-	-	x <sup>2)</sup>	x	x
4820 mm	-	x	x	x	x	x <sup>1)</sup>	-	-
5360 mm	-	-	-	-	-	x <sup>2)</sup>	x	x
5420 mm	-	-	-	-	-	x <sup>1)</sup>	-	-
5960 mm	-	-	-	-	-	x <sup>2)</sup>	-	-
6260 mm	-	-	-	-	-	x <sup>2)</sup>	x	-
<b>Cab variants</b>								
S cab ClassicSpace	x	x	x	x	x	x	x	x
S cab ClassicSpace extended	x	x	x	x	x	x	x	x
L cab ClassicSpace	x	x	x	x	x	x	x	x
L cab BigSpace	x	x	x	x	x	x	x	x

							
6.5	7.49	7.99	9.5	10.5	11.99 <small>also available with low frame</small>	13.5	15
4 x 2	4 x 2	4 x 2	4 x 2	4 x 2	4 x 2	4 x 2	4 x 2
Air	Air	Air	Air	Air	Air	Air	Air
x							
-	x	x	x	-	x	x	x
-	x	x	x	x	x	x	x
-	-	x	x	x	x	x	x
-	-	x	x	x	x	x	x
-	-	-	-	-	x <sup>2)</sup>	x	x
-	-	-	-	-	x <sup>2)</sup>	x	x
-	x	-	-	-	-	-	-
-	x	-	-	-	-	-	-
-	-	-	-	-	x <sup>2)</sup>	x	x
x	x	x	x	x	x <sup>1)</sup>	-	-
-	-	-	-	-	x <sup>2)</sup>	x	x
x	x	x	x	x	x <sup>1)</sup>	-	-
-	-	-	-	-	x <sup>2)</sup>	x	x
-	x	x	x	x	x <sup>1)</sup>	-	-
-	-	-	-	-	x <sup>2)</sup>	x	x
-	-	-	-	-	x <sup>1)</sup>	-	-
-	-	-	-	-	-	-	-
-	-	-	-	-	-	-	-
x	x	x	x	x	x	x	x
x	x	x	x	x	x	x	x
x	x	x	x	x	x	x	x
x	x	x	x	x	x	x	x

x available    - not available    <sup>1)</sup> Only available for variant with low frame    <sup>2)</sup> Only available for variant with standard frame

**Please note:** changes may have been made to the product since this brochure went to press (15.01. 2013). The manufacturer reserves the right to make changes to the design, form, colour and specification during the delivery period, provided these changes, while taking into account the interests of the vendor, can be deemed reasonable with respect to the purchaser. Where the vendor or the manufacturer uses symbols or numbers to describe an order or the subject of an order, no rights may be derived solely from these. The illustrations may show accessories and items of special equipment which are not part of standard specification. Colours may differ slightly from those shown in the brochure, owing to the limitations of the printing process. This brochure may also contain models and services which are not available in certain countries. This brochure is distributed internationally. It provides a general indication of the range of models, features, special equipment and/or colours available in various countries. Some of the models, features, special equipment and/or colours may not be available in your country, or may only be available in a different specification. Additionally some models, features, special equipment and/or colours may only be available in combination with others. For current and more specific information relating to the range of models, features, special equipment and/or colours available in your country, and their pricing, you should contact your nearest authorised Mercedes-Benz truck dealer.

Telligent®, FleetBoard® and BlueTec® are registered trademarks of Daimler AG. [www.mbtrucks.co.uk/newatego](http://www.mbtrucks.co.uk/newatego)