

C-Class Coupé



Mercedes-Benz





First impressions

On the outside, it's a dynamic coupé whose looks never fail to cause a stir. Inside, however, it's an oasis of calm, a place to relax and enjoy every bend and straight in total comfort. It's the C-Class Coupé, a winning combination of luxury, personality and driving pleasure.

With efficient powerful engines, ECO start/stop, Agility Control suspension and standard-setting safety technology.

[Overview](#) | [from page 4](#) [Insights](#) | [from page 11](#)

Featured models:

C 350 AMG Sport | Palladium Silver metallic | front page and page 2
AMG alloy wheels in 7-spoke design, dark brushed aluminium trim,
Driving Assistance Package, COMAND Online system

C 250 CDI AMG Sport | Diamond White metallic | page 9
AMG alloy wheels in 7-spoke design, Black cloth/Artico artificial leather

Specifications shown may include optional equipment and accessories



With an iPad® you can download the interactive C-Class Coupé brochure app either by scanning the QR code or by visiting the App Store



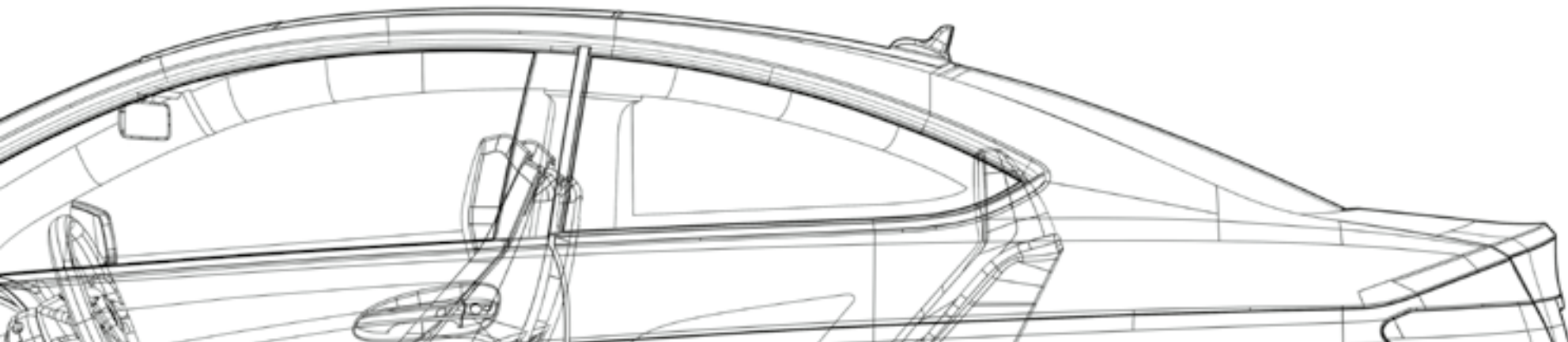

Facts

Agile style: Mercedes-Benz Intelligent Drive, BlueEFFICIENCY, diesel and petrol engines, transmissions and AMG Handling Package.

Engines and AMG Handling Package | from page 16

Integrated safety in the C-Class Coupé: safer driving, anticipating danger, protecting occupants and post-crash safety.

Safety | from page 20

Relaxing enjoyment: multimedia systems, electronic assistants and coupé-specific seats.

Comfort | from page 24

Adrenalin machine: the C 63 AMG and C 63 AMG Edition 507, C 63 AMG technology and AMG Performance Studio options.

AMG | from page 30

Your personal coupé: standard equipment and optional extras, model lines, alloy wheels and Retailer-fit accessories.

Equipment | from page 36

More Mercedes-Benz: test drive, Mercedes-Benz Finance and Insurance, Interactive Owner's Manual, Roadside Assistance and Accident Management, Service Care and Mercedes-Benz World.

Services | from page 56

C-Class Coupé in figures: dimensions, paint finishes and technical data.

Facts and finishes | from page 58



Two doors, no compromises: concentrated coupé flair

The stance is low-slung; the face unmistakable, a large three-pointed star dominating its two-bar grille. The rear? Compact, muscular and broad-shouldered. It's a coupé for those who don't stand still.



Care instructions:
apply regularly to tarmac







Having thoughts about the environment? We're with you.

The C-Class Coupé comes with engines that achieve significant reductions in fuel consumption. What's more, its ECO start/stop function and the optional 7G-Tronic Plus automatic transmission help to improve efficiency even further. Good for your conscience – and for your wallet. → pages 16–18



Welcome to the coupé lounge



Your first Mercedes?
We promise it won't be your last



A sixth sense also comes as standard

The C-Class Coupé always seems to know what's just ahead. Its safety systems are constantly evaluating the current situation and anticipating the next, helping you to stay out of danger whenever possible. The Adaptive Brake System, for instance, can prime the brakes even before you press the pedal, ensuring they react faster – and bring the car to a standstill more quickly.





Best of breed

At the heart of the new DTM AMG Mercedes-Benz Coupé is a unique safety concept featuring an innovative safety cell with a carbon-fibre monocoque and a pilot cage made from reinforced steel.

The C-Class family can look back on an unparalleled DTM (German Touring Car Championship) success story. In its first season in 1988, Mercedes-Benz – with the help of AMG – was runner-up with the 190 E 2.5-16 EVO, the racing version of the famous C-Class predecessor. With 85 victories in 159 races, the C-Class is the most successful car in the history of the DTM.

Fingers crossed for the DTM AMG Mercedes C-Coupé to be first past the post in the coming season.

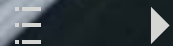

14 **Mercedes-Benz Intelligent Drive**15 **BlueEFFICIENCY**16 **Diesel engines**

4-cylinder engines

Additional efficiency measures

17 **Petrol engines**

4-cylinder engines

V6 engine

Additional efficiency measures

18 **Transmissions**

6-speed manual transmission

7G-Tronic Plus

19 **AMG Handling Package**20 **Integrated safety concept**

Attention Assist

Intelligent Light System

Adaptive High Beam Assist

Lane-Tracking Package

Driving Assistance Package

Pre-Safe® Brake and BAS Plus

Pre-Safe® system

Neck-Pro active head restraints

Restraint systems

Active Bonnet

Mercedes-Benz Emergency Call System

Rescue assistance

24 **Multimedia systems**

COMAND Online system

Harman Kardon® Logic 7®

surround sound system

Audio 20 radio with Bluetooth®

interface and USB port

Becker® Map Pilot navigation system

26 **Electronic assistants**

Speed Limit Assist

Reversing camera

Parktronic with Advanced

Parking Guidance

28 **Seats**

Coupé-specific front seats

Individual rear seats with integral

head restraints

Memory Package

30 **C 63 AMG**32 **C 63 AMG Edition 507**34 **C 63 AMG technology**

AMG 6.3-litre V8

AMG sports suspension

AMG Speedshift MCT 7-speed

sports transmission

35 **AMG Performance Studio**

36 Standard equipment**37 Optional extras****38 Model variants**

Executive SE

AMG Sport

AMG Sport Plus

44 Upholstery and trim**53 Alloy wheels****54 Retailer-fit accessories****56 Services**

Test drive

Mercedes-Benz Finance and Insurance

Interactive Owner's Manual

Roadside Assistance and

Accident Management

Service Care

Mercedes-Benz World

58 Dimensions**59 Technical data****61 Paint finishes**

Mercedes-Benz Intelligent Drive – a new era in mobility

Our engineers focus on the future every day in order to make innovative technology a reality. This aspiration has resulted in developments with a lasting impact on automotive engineering. In other words, our work ensures that a Mercedes-Benz will always be ahead of its time.

We have developed one groundbreaking solution after another to get closer to realising our vision of safe and accident-free driving. Innovative technologies such as the Pre-Safe® anticipatory safety system and DISTRONIC Plus radar-assisted cruise control first made it onto the road in a Mercedes-Benz, setting new standards in vehicle safety. It marked the first time active and passive systems were combined – for even better protection and ride comfort.

Mercedes-Benz Intelligent Drive takes things a step further by intelligently combining sensors with safety systems and electronic assistants. For us, it's a logical progression as the traffic situation has changed. There are more vehicles on the road, the driver's job is becoming more complex and distractions are increasing.

Once again, we have revolutionised the car to provide even more assistance and to help deal with road situations effectively: today, a Mercedes-Benz has an even greater spatial awareness. It has a better view of the road and other road users, and it can react to what it sees.

We have developed a stereo camera system that is capable of capturing three dimensions. Together with further sensors, this produces a 360° view – a precise image of the surroundings. If the safety systems and electronic assistants detect danger, they can respond within a fraction of a second to provide the driver with the right assistance for the situation in hand. For example, by performing an emergency braking manoeuvre in dangerous situations, or by dimming part of the main beam for the benefit of oncoming traffic.

Pioneer of innovation – Mercedes-Benz Intelligent Drive once again underlines our leading ambition and points the way ahead to accident-free and autonomous driving. The following pages include further information about our safety and comfort systems. They are available as standard equipment or optional extras for the E-Class, depending on the model specification. Further details can be found on pages 28–31 and 34–35.



BlueEFFICIENCY – fast forward to tomorrow

Mercedes-Benz is quicker at getting future technologies to where they matter most: on the road. With ever more efficient vehicles and a production process that wastes fewer and fewer resources. We call this comprehensive approach BlueEFFICIENCY. By way of example, BlueTEC technology for the diesel engine reduces nitrogen oxide

emissions by up to 90%. Our Hybrid models featuring an intelligent combination of internal combustion engine and electric drive can reduce fuel consumption significantly, while the SLS AMG Coupé Electric Drive takes electric mobility to a new level.



- 1 Radiator shutter
- 2 Enhanced aerodynamics
- 3 Weight savings
- 4 Optimised engines
- 5 Intelligent energy management
- 6 ECO start/stop function¹
- 7 Driver information that encourages fuel-efficient driving style
- 8 Tyres designed for lower rolling resistance
- 9 Energy-saving fuel pump (diesel models) and power steering pump
- 10 Air-conditioning compressor only active on demand

¹ Not available on C 63 AMG or C 63 AMG Edition 507



Diesel engines

The diesel engines for the C-Class Coupé are efficient, refined and powerful, offering significantly higher outputs and lower fuel consumption than conventional diesel units.

4-cylinder diesel engines. Impressive performance is achieved courtesy of a range of technical innovations, resulting in figures of 170 hp (125 kW) for the C 220 CDI and 204 hp (150 kW) for the C 250 CDI. The high-pressure injection system injects fuel at up to 2,000 bar and sends only the required amount of fuel into the combustion chambers. The chambers themselves have been optimised to ensure fuel burns as cleanly and efficiently as possible, while the intelligent alternator management

system means the alternator is only active when needed, reducing the load on the engine. There are also efficient twin turbochargers and twin balancer shafts that keep the engine running smoothly at all times.

Both 4-cylinder diesel models come with the ECO start/stop function and meet the EU5 standard for exhaust emissions.

Additional efficiency measures. All our engines come with ECO start/stop,¹ almost imperceptibly cutting the engine when the car is stationary or coming to a complete standstill. The ECO display that is available on many models evaluates the efficiency of the driver's driving style, allowing the driver to actively reduce consumption.

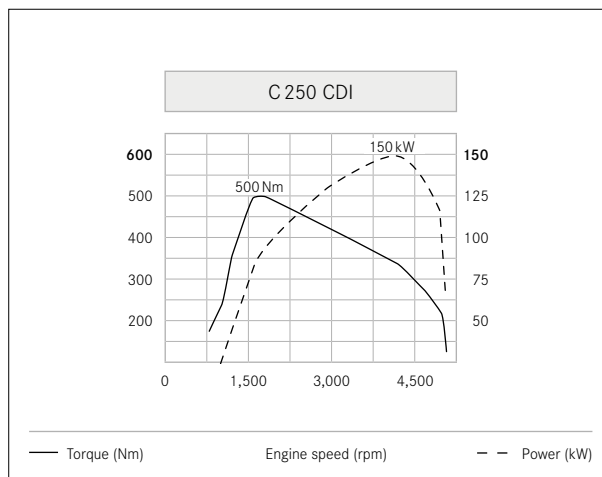

With high levels of torque even at low engine speeds, the C 250 CDI delivers instant acceleration

¹ Not available on C 63 AMG or C 63 AMG Edition 507



The 4-cylinder engine for the C 220 CDI features advanced Mercedes-Benz diesel technology



Petrol engines

Enjoyment and efficiency can go hand in hand – as the C-Class Coupé's petrol engines prove. Both the 4-cylinder models and V6 variant deliver exceptionally refined performance and impressively low fuel consumption.

4-cylinder petrol engines. Our petrol engines offer both increased power and reduced fuel consumption. It's a feat they achieve thanks to advanced engine technology. Direct injection at up to 200 bar gives an optimum air/fuel mixture and increased engine efficiency. The engine management also optimises the valve timing by adjustment of the camshafts and uses multi-hole piezo injectors. A particular benefit is the saving in engine weight by using a cast hollow crankshaft and

aluminium for the cylinder block. Further optimisation brings additional savings in consumption – the electronic steering in the C180 and C 220 CDI manual, for example. It only draws energy when the steering wheel is moved – without any loss in comfort.

The C 180 accelerates from 0 to 62 mph in 8.5 seconds and goes on to reach a top speed of 140 mph, while the C 250 dispatches the same sprint in just 7.2 seconds and continues all the way up to a maximum 149 mph.

which ensures precisely the right amount of fuel is used for any given situation.

Additional efficiency measures. All our engines come with ECO start/stop,¹ almost imperceptibly cutting the engine when the car is stationary or coming to a complete standstill. The ECO display that is available on many models evaluates the efficiency of the driver's driving style, allowing the driver to actively reduce consumption.

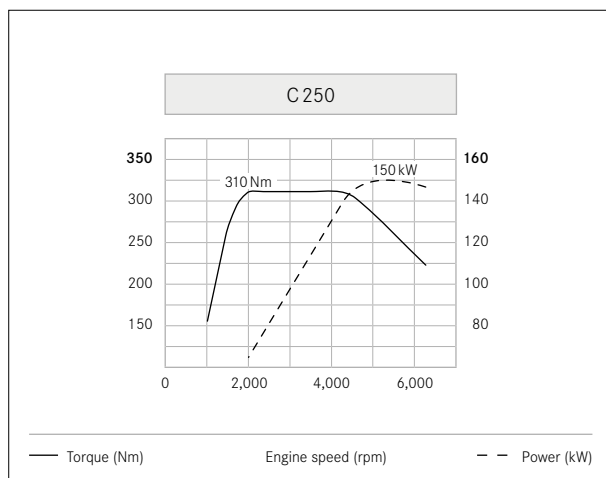

The power and torque curves are impressive, the fuel consumption figures even more so

V6 petrol engine. Powerful, economical and clean, the C 350 perfectly embodies the virtues of our petrol engines. Despite delivering 306 hp (225 kW) and accelerating from 0 to 62 mph in just 6.0 seconds, it achieves a remarkably frugal 40.4 mpg on the combined cycle. What's more, its peak torque of 370 Nm is available across a broad rev range, ensuring instant responses whatever the situation or speed. The key to this impressive blend of efficiency and performance is our latest-generation direct petrol injection system. It features spray-guided combustion and highly precise piezo injectors and works in conjunction with continuously variable camshaft control,



The C 350 combines excellent performance with efficient use of fuel

¹ Not available on C 63 AMG or C 63 AMG Edition 507

Transmissions

The transmissions for the C-Class Coupé ensure optimum performance whatever the situation or engine speed.

6-speed manual transmission. The 6-speed manual transmission combines impressive efficiency with a sporty feel. The ratios are ideally matched to the engine and the short, precise shift throws ensure every gear change is a pleasure. Manual C-Class Coupé models are equipped with a shift point indicator and current fuel consumption display that help you to optimise efficiency and reduce CO₂ emissions. The standard ECO start/stop function, meanwhile, helps to achieve further fuel-savings, cutting the engine automatically when stationary or coming to a standstill, and restarting it as soon as you touch the accelerator or depress the clutch.

7G-Tronic Plus. 7G-Tronic Plus is the latest version of our 7-speed automatic transmission. It helps to improve fuel consumption by ensuring the engine is always operating at the optimum speed, yet delivers faster, smoother shifts and better acceleration too, even skipping gears in kick-down for more rapid overtaking. In addition, 7G-Tronic Plus allows you to switch between comfort and sport modes as the mood takes you. 7G-Tronic Plus comes as standard on the C 250 and C 350 and is available as an option on all other models.

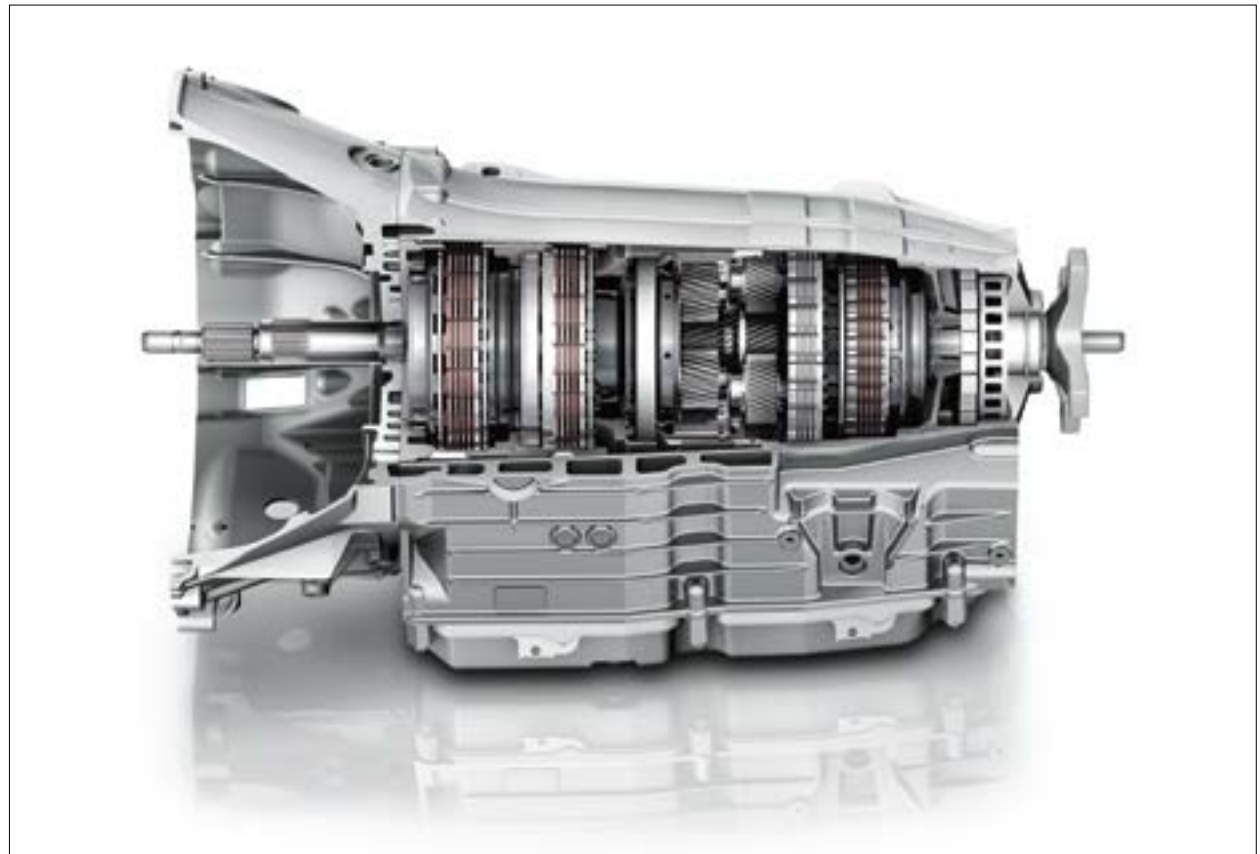

7G-Tronic Plus: the result of more than 50 years' experience in automatic transmission technology

AMG Handling Package

Style guide for the perfect bend: match the new AMG Handling Package with the AMG Sport Plus model.

The AMG Handling Package offers technical and styling enhancements, carefully 'engineered by AMG' for the true sports enthusiast (optional on AMG Sport Plus; only available on C 250 BlueEFFICIENCY and C 250 CDI BlueEFFICIENCY with automatic transmission). The larger brakes, sports exhaust and sports tuning of the engine and transmission lend even greater driving dynamics to the AMG Sport Plus. These additions are complemented with subtle exterior styling cues including black exterior mirrors, sport badging on the front wings and floor mats; and a black lamella grille with chrome highlights.



Integrated safety concept

The C-Class Coupé comes with a host of safety features that help to avoid danger and make for a more relaxing journey.

As the inventor of the motor car, we feel a particular responsibility towards road safety. That's why we were the first manufacturer to develop an integrated safety concept that seamlessly combines a car's active and passive safety features, thus ensuring optimum all-round protection. This concept covers four different areas – safer driving, anticipating danger, protecting occupants and post-crash safety – and incorporates measures designed to maximise safety in every situation, by helping you to stay safe, alerting you to danger, and assisting you wherever possible. In addition, our unique Pre-Safe® anticipatory safety system recognises likely accident scenarios and takes steps that help to further enhance occupant protection. If a collision can't be avoided, intelligent passive safety systems help to provide protection where it's needed, while solutions that can minimise the consequences of an accident and facilitate emergency assistance are also a key part of this safety concept.

A selection of these technologies for the phases 'safer driving', 'anticipating danger', 'protecting occupants' and 'post-crash safety' are presented on the following pages.

Safer driving: Attention Assist (standard). If it detects signs of tiredness, Attention Assist alerts the driver via visual and acoustic warnings and recommends taking a break. It monitors driver behaviour via an array of sensors and registers unexpected changes that may indicate drowsiness or concentration lapses.

Safer Driving: Intelligent Light System (optional). This system comprises five modes: high-performance headlamps with country mode shining more light towards road edges, motorway mode to illuminate the entire width of the lane, fog mode for improved visibility in bad weather conditions, Active Cornering light as well as Active Light System for better visibility in bends.

Safer Driving: Adaptive High Beam Assist (optional). Adaptive High Beam Assist consistently offers the maximum lighting range and adapts to the current road situation. The system activates the high beam, if no oncoming vehicles are detected and lowers it again as soon as the lights of oncoming traffic are identified.

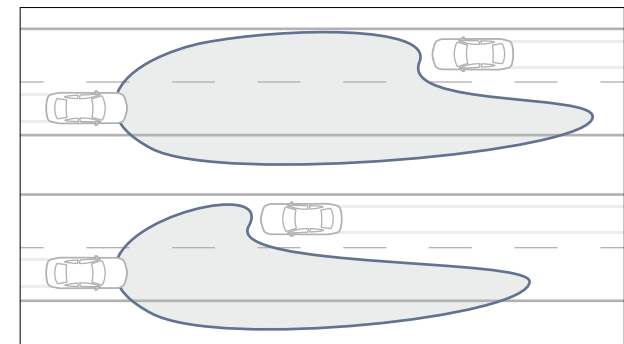

The Intelligent Light System automatically optimises visibility in a range of different situations

Safer driving: Lane-Tracking Package (optional). Using the lane markings on the tarmac, Lane-Keeping Assist can detect when the car veers off course unintentionally and warn the driver accordingly with gentle vibrations of the steering wheel. The Blind Spot Assist helps avoid dangerous lane changing manoeuvres using twin radar sensors in the rear bumpers.



Blind Spot Assist alerts the driver with an acoustic warning and a flashing red triangle in the side mirror

Safer driving: Driving Assistance Package (optional on all models except Executive SE). This package comprises a range of intelligent safety technologies. Active Lane-Keeping Assist draws the driver's attention to unintended lane changes, gently vibrating the steering wheel if the car wanders across lane markings. If the driver doesn't react to the warning, the system is able to intervene in order to correct the car's course. Active Blind Spot Assist makes intentional lane changes safer too, using twin radar sensors to watch over the areas not visible in your exterior mirrors. If the sensors spot a vehicle in

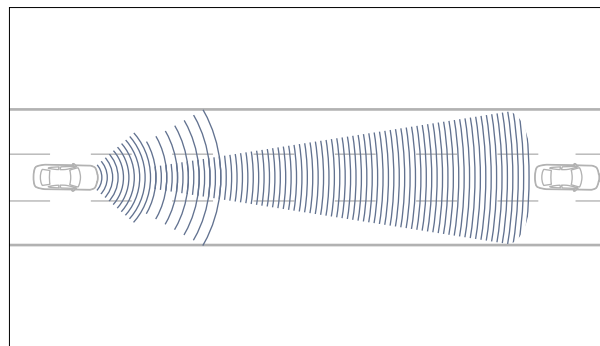

DISTRONIC PLUS can bring the car to a standstill and get you moving again automatically – an advantage in stop/start driving

one of these blind spots, a flashing red triangle appears in the corresponding mirror, accompanied by an acoustic warning from the instrument panel. Should the driver nevertheless proceed to change lanes, the system can intervene and help prevent a collision by automatically applying the brakes on the appropriate side. DISTRONIC PLUS radar-assisted cruise control, meanwhile, enables the car to automatically maintain a preset distance from the vehicle in front, both in high-speed driving and in stop/start traffic. Also included in the package are our Brake Assist (BAS Plus) and Pre-Safe® Brake system – to give that feeling of safety on every trip.

Anticipating danger: Pre-Safe® Brake and BAS Plus

(part of optional Driving Assistance Package). If it detects the risk of a collision, Pre-Safe® Brake alerts the driver via visual and audible warnings. At the same time, BAS Plus assesses the brake force required in order to avoid an impact. If the driver applies the brakes but uses insufficient force, BAS Plus automatically raises the braking pressure to a level that exploits the remaining stopping distance to the full, thereby also lessening the likelihood of a shunt from behind.

Should the driver fail to react to Pre-Safe® Brake's warning signals, it slows the car automatically, providing a further warning, and triggers a range of Pre-Safe® measures. If the driver still doesn't respond, the system then initiates autonomous emergency braking, enabling the speed and severity of any impact to be significantly reduced.

Anticipating danger: Pre-Safe® system (standard). If it detects a probable accident scenario, Pre-Safe® anticipatory safety system can take a range of anticipatory measures to reduce the risk of injury to the occupants. These include activating the front seat belt tensioners, automatically closing the windows and, if the optional Memory Package is fitted, moving the front passenger seat to a more favourable position.

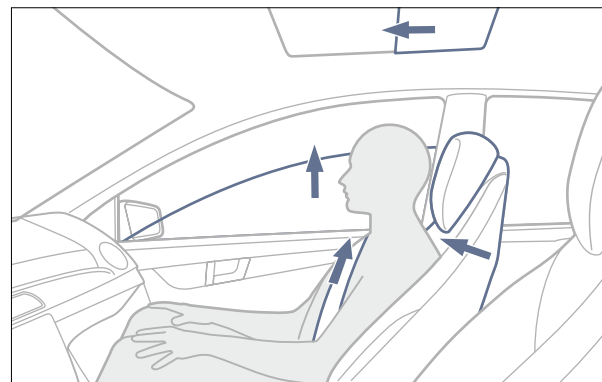

The Pre-Safe® system can detect critical situations and take anticipatory measures to enhance occupant protection

Anticipating danger: Neck-Pro active head restraints

(standard). The Neck-Pro front head restraints help to reduce the risk of whiplash injuries. Within milliseconds of a rear-end impact, they automatically move forwards and upwards, enabling them to support the head sooner.

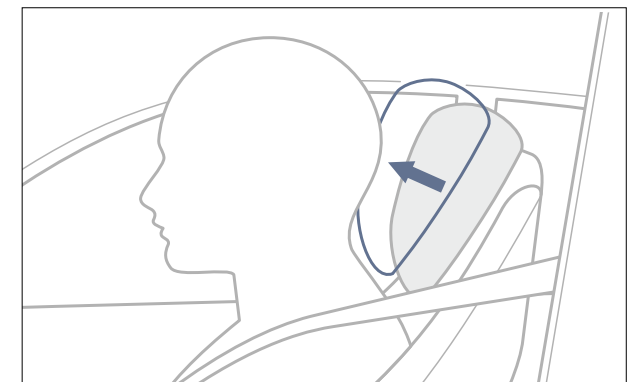

The Neck-Pro active head restraints can help to avoid whiplash injuries in rear-end collisions

Protecting occupants: restraint systems (standard).

The 3-point seat belts, seat belt tensioners, belt force limiters and airbags are all carefully coordinated so as to keep injuries to a minimum. The C-Class Coupé is fitted with numerous airbags to ensure optimum occupant protection, with front, side, pelvisbags for the driver and front passenger, a kneebag for the driver and windowbags as standard. Sidebags are optional for the rear. If the crash sensors detect an impact, the seat belts are instantly tensed, helping to ensure the occupants remain firmly in

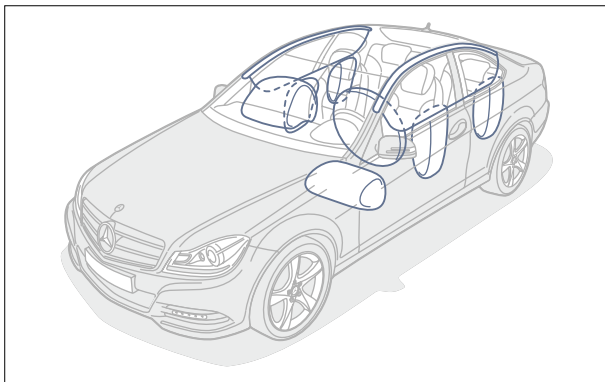

The rigid passenger cell, front and rear crumple zones and intelligent restraint systems provide optimum protection in the event of an impact

their seats, while the belt force limiter relaxes the belt as the situation allows, in order to prevent undue force being applied to the rib cage.

Protecting occupants: Active Bonnet (standard).

The Active Bonnet helps reduce the risk of injury to more vulnerable road users, such as pedestrians and cyclists. On impact, the bonnet springs up by 5 cm to better absorb the collision.

Post-crash safety: Mercedes-Benz Emergency Call System (part of COMAND Online systems).

The system can automatically send an emergency call via an operational telephone connected to the vehicle, as soon as the restraint system detects a collision. The GPS coordinates are sent to the Mercedes-Benz emergency call centre and a speech connection is then set up. The emergency call can also be triggered manually.

Post-crash safety: rescue assistance. Mercedes-Benz has developed a range of measures that help to minimise the secondary consequences of an accident and facilitate occupant rescue. These include automatic engine cut-off, self-activating hazard lights and emergency cabin lighting. In addition, the central locking system is automatically released in the event of an accident, and there are special crash joints between the front doors and wings that make it easier to open the doors after frontal collisions. In addition, Mercedes-Benz provides a rescue guide for emergency services that can be downloaded from the Internet at www.mercedes-benz.co.uk/rescueguide

Multimedia systems

With its high-quality multimedia and navigation systems, the C-Class Coupé helps you to reach your destination as swiftly as possible – and keeps you entertained all the way.



The large TFT display presents maps, videos or online content in high resolution

COMAND Online system (optional). COMAND Online combines hard disk drive navigation with in-car Internet access and a wide range of entertainment features. These include speed-sensitive volume adjustment, a music library with 10 GB of storage space for audio files and a DVD drive that plays CDs, MP3s, and video or audio DVDs. It also enables you to connect a variety of external devices and storage media – via USB port, Media Interface, SD memory card slot or Bluetooth® interface – and lets you access not only Mercedes-Benz services online, but connects to the Internet for weather updates, Google Street View or Facebook, or helps to find parking facilities while on the move (Internet-enabled mobile phone required). Live Traffic receives precise and up-to-date traffic information, which is fed into the navigation system. Maps and menus are presented on a high-resolution 7-inch colour display. Three years of map updates are offered free of charge. All key functions can be operated either via the central controller, from the multi-function steering wheel or using Linguatronic voice control.



Harman Kardon® Logic 7® surround sound system (optional). With its 12 high-performance speakers and Logic 7® multi-channel spatial sound technology, this 450-watt surround sound system makes every journey a listening experience to remember. In addition, it comes with speed-sensitive volume adjustment that levels the audio output as you drive.



The Harman Kardon® Logic 7® surround sound system offers a truly first-class listening experience

Audio 20 radio with Bluetooth® interface and USB port (standard). The Audio 20 system features a radio, a 6-disc CD changer with MP3 playback, a USB port, and a Bluetooth® interface for hands-free mobile telephony. It also comes with a 5.8-inch TFT display and can be operated remotely via the multi-function steering wheel. A DAB digital radio tuner is included as standard on the C-Class Coupé.



The Audio 20 system features eight carefully combined speakers that deliver excellent sound

Becker® Map Pilot navigation system (optional). With the Becker® Map Pilot navigation system, you'll always reach your destination as safely and quickly as possible. Installed in the glove compartment, the Map Pilot can be integrated with Audio 20 CD system's central controller and display and tailored to your needs by downloading additional functions and map data.



Electronic assistants

The C-Class Coupé is available with electronic assistants that enhance safety and convenience in a range of situations. They can help you to avoid danger during lane changes, lend a hand in low-speed manoeuvres – and even keep an eye on the speed limit for you.



Speed Limit Assist even recognises and displays temporary speed restrictions

Speed Limit Assist (fitted with the optional COMAND Online system). Speed Limit Assist reads speed limit signs and displays the permitted maximum speed in the instrument panel and on the COMAND Online navigation screen until the limit changes. Its front-mounted camera detects round speed limit warnings, both on roadside signs and on overhead gantries, and is particularly useful in areas where the speed limit varies or when passing through roadworks. To help identify the limit correctly, it compares speed limit signs with map data from the navigation system, enabling it to recognise when you are entering or leaving built-up areas for instance.

Reversing camera (optional; only in conjunction with COMAND Online system). This rear-mounted camera makes for safer and easier parking manoeuvres. Activated automatically as soon as the driver engages reverse, it captures the area immediately behind the car and enables you to see the image on the COMAND Online display.



The reversing camera makes for easier manoeuvring in tight spaces

Parktronic with Parking Guidance (standard). Parktronic uses the sonar principle to help you avoid low-speed knocks during parking manoeuvres. It sends out ultra-sound signals that reflect off other objects and are picked up by sensors in the front and rear bumpers. The system then processes this information and calculates the size of the gap to the front and rear, enabling it to alert you via acoustic and visual warnings as you approach the vehicle or object.



At speeds of up to 20 mph, Parking Guidance can automatically measure the length of parallel parking spaces

Parking Guidance can help you to find and manoeuvre into parking spaces. At speeds of around 20 mph, it measures gaps in lines of parallel-parked cars and alerts you as soon as it finds a suitably sized space. Once reverse is engaged, it then guides you in via a combination of acoustic signals and graphics in the instrument panel, showing the required steering angle and telling you when to turn the wheel.

Seats

The C-Class Coupé features coupé-specific front seats, individual rear seats and integral head restraints all round. Its eye-catching seats not only look the part, they also offer excellent ergonomics and high levels of support even in sporty driving.



Coupé-specific front seats lend the C-Class Coupé cabin a sporty look and feel

Coupé-specific front seats. For the driver and front seat passenger, the C-Class Coupé offers ergonomically designed coupé-specific seats. They come with supportive side bolsters and have electric seat height and backrest angle adjustment as standard. Heated or comfort-ventilated seats are also available as an option.

Individual rear seats with integral head restraints. Those in the rear benefit from ergonomic, individually sculpted seats with integral head restraints. They echo the sporty style of the coupé-specific front seats and come with an asymmetric split/fold mechanism. Also fitted as standard is the Easy-Entry system, which provides more convenient access to the rear seat accommodation.





The standard Easy-Entry system facilitates access to the rear, sliding the front seats all the way forward when released

Memory Package (optional). The optional Memory Package ensures you can always find your preferred driving position quickly and easily, even if your C-Class Coupé is regularly driven by someone else. It allows up to three different driver's seat, steering column and exterior mirrors positions to be stored and recalled at any time.



With the optional Memory Package, your preferred driving position can be restored at the touch of a button

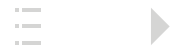



Image shows optional 19" AMG multi-spoke alloy wheels in matt black (code 797)



C 63 AMG

The C 63 AMG Coupé combines the race-honed technology of its four-door cousins with a dramatic and highly individual style. Its sporty coupé lines are made even more eye-catching by the AMG grille with single chrome louvre, an AMG-specific bonnet with powerdomes, and AMG bodystyling comprising front and rear aprons plus side skirts. The AMG sports exhaust system's two sets of twin chromed tailpipes provide a further clue to the power of this exhilarating coupé, while AMG-specific daytime running lights and 18" 5-twin-spoke AMG alloy wheels in burnished Titanium Grey finish also come as standard (19" AMG multi-spoke wheels in Titanium Grey or black are available as an option).

Exterior

18" AMG 5-twin-spoke alloy wheels with burnished Titanium Grey finish

AMG bodystyling, comprising front apron with side air vents and gloss black cross-bar, side skirts and diffuser-style rear apron

AMG boot lid spoiler (body-coloured)

AMG high-performance braking system with 360 × 36 mm front brake discs and 330 × 26 mm rear discs

LED rear tail lights

Panoramic sunroof

Wider front wings with '6.3 AMG' badges





Stylish, sporty and highly exclusive, the interior of the C 63 AMG Coupé feels instantly special. Its supportive AMG sports seats are upholstered in Black single- or two-tone *designo* leather. The flat-rimmed AMG Performance steering wheel features tactile nappa leather trim and aluminium gear shift paddles, and there's an ergonomic AMG-specific instrument panel with colour display and AMG start-up screen. Eye-catching AMG door sill strips and brushed stainless steel sports pedals also come as standard (carbon-fibre trim is available as an option).
 → www.mercedes-benz.co.uk/amg



Image shows optional carbon-fibre trim

Interior

Aluminium trim

AMG door sill strips in brushed stainless steel

AMG instrument panel with high-resolution 4.5-inch colour display, including Racetimer and AMG start-up screen

AMG sports parameter steering

AMG sports seats with *designo* Black leather upholstery

Attention Assist

Brushed stainless steel sports pedals with rubber studs

COMAND Online system with Media Interface

DAB digital radio tuner

Flat-rimmed AMG Performance steering wheel with nappa leather trim and aluminium gear shift

Rotary switch for transmission modes and Race Start function





C 63 AMG Edition 507

The C 63 AMG Edition 507 adds further drama to both the performance and styling of the C 63 AMG. The extra 50 hp is hinted at by the dual air intakes in the bonnet, the gloss Black exterior trim and the AMG sport stripe in matt Graphite Grey. A unique design of 19" forged alloy wheels – available in Titanium Grey or matt black – is complemented by red brake calipers, creating a stylish and dynamic finish to this high-performance model.



Exterior

AMG Driver's Package

AMG bonnet with powerdomes and air outlets in high-gloss black

AMG boot lid spoiler in black

AMG high-performance composite brake system with 3-stage ESP® and composite front brake discs

AMG sport stripe in matt Graphite Grey

Brake calipers painted red

LED daytime running light surround and radiator grille border in high-gloss black

Images show optional *designo* Magno Platinum paint (code 051) and optional 19" AMG forged wheels in cross-spoke design, painted matt black (code 793) or Titanium Grey (code 785)





Image shows optional *designo* Porcelain leather/Black Dinamica (code X87)

The interior of the C 63 AMG Edition 507 is unmistakably performance driven. The full Alcantara® steering wheel with 12 o'clock marking sits in front of the AMG instrument cluster featuring red accents. Detailed touches include the AMG emblem on the gear shift lever and 'Edition 507' badging integrated into the dashboard trim. Three seat upholsteries are available, with the unique combination of Porcelain leather/Black Dinamica microfibre being shown here.



Interior

AMG Performance 3-spoke steering wheel in Alcantara® with contrast stitching and 12 o'clock marking

AMG instrument cluster with red applications

AMG stainless steel- and Dinamica-trimmed gear shift lever with contrast stitching and AMG emblem

Trim – High-Gloss Black with 'Edition 507' badging



C 63 AMG technology

The AMG 6.3-litre V8 delivers exceptional power, the sports transmission and suspension help you exploit it to the full – and let you switch between performance- and comfort-biased set-ups. → www.mercedes-benz.co.uk/amg

AMG 6.3-litre V8. Under the bonnet of the C 63 AMG is a naturally aspirated V8 equipped with track-honed racing technologies. These include variable camshaft timing, four valves per cylinder, an exceptionally rigid aluminium crankcase and a special low-friction coating for the cylinder contact surfaces. For optimum cylinder charging, this high-tech engine also features vertically arranged intake and exhaust ports plus a magnesium variable intake manifold with twin throttle flaps. The result is free-revving performance, exceptional pulling power and instant acceleration at all speeds. The C 63 AMG delivers 457 hp (336 kW) at 6,800 rpm, plus 600 Nm of torque at 5,000 rpm, with in excess of 500 Nm available all the way from 2,000 to 6,250 rpm. The C 63 AMG Edition 507 delivers even more power: it increases output to 507 hp (373 kW), enabling it to accelerate from 0 to 62 mph in a breathtaking 4.2 seconds (4.5 seconds for the C 63 AMG).

AMG sports suspension. The AMG sports suspension offers outstanding agility and exceptional lateral acceleration potential. Together with the low-profile tyres, wide front track, AMG sports parameter steering and three-stage ESP®, it ensures exceptional vehicle dynamics and an exhilarating driving experience. The triple-link front suspension, firm springing and gas pressure dampers guarantee optimum roadholding and excellent body control even at the limit, yet the ride remains as comfortable as you'd expect from a Mercedes, even on longer journeys. The AMG sports parameter steering features a more direct ratio that gives greater steering precision and allows for even higher cornering speeds, while the Electronic Stability Programme (ESP®) is also tailored to the C 63 AMG's high-performance needs. It lets you determine the level of ESP® support yourself, allowing you to switch between 'on', 'off' and 'sports handling' modes, and displaying the current setting in the instrument panel. As an option, the C 63 AMG Coupé can be fitted with AMG Performance suspension. Its tauter spring and damper settings make for even faster handling responses and a thoroughly focused feel.

AMG Speedshift MCT 7-speed sports transmission. Equipped with AMG aluminium steering wheel shift paddles, four driving modes and a Race Start function, the C 63 AMG's 7-speed sports transmission maximises performance yet delivers high levels of efficiency. The 'S' (Sport), 'S+' (Sport Plus), 'C' (Comfort) and 'M' (Manual) modes each offer different shift characteristics and speeds: gear changes in Sport and Sport Plus modes are around 20% and 40% faster respectively than in Comfort mode, while Manual mode is approximately 50% faster, with shift times of just 100 milliseconds. The transmission also offers automatic throttle-blipping on downshifts. This not only produces a satisfyingly sporty sound, it also helps to reduce load transfer, especially when braking into bends.





AMG Performance Studio

For an even sportier C 63 AMG, simply add options from the AMG Performance Studio. Allowing you to further customise your unique model, options range from visual enhancements such as illuminated AMG door sills or AMG Carbon-Fibre Trim Packages, to performance-oriented options such as AMG rear axle limited-slip differential lock or an AMG Performance suspension. Also available is the AMG Driver's Package (standard on C 63 AMG Edition 507), which raises the electronically limited top speed and includes participation at an AMG 'Power & Passion' driving event.



Image shows optional AMG Interior Carbon-Fibre Trim Package (code H73)

AMG Performance Studio

18" AMG 5-twin-spoke alloy wheels in burnished Titanium Grey finish,¹ or 19" AMG multi-spoke alloy wheels, painted in Titanium Grey¹

AMG Driver's Package (standard on C 63 AMG Edition 507)

AMG Exterior Carbon-Fibre Trim Package, comprising carbon-fibre boot lid spoiler and exterior mirror housings¹

AMG carbon-fibre interior trim

AMG illuminated door sill panels

AMG Performance Media

AMG rear axle limited-slip differential lock

¹Not available on C 63 AMG Edition 507



Standard equipment | Selection



Intelligent Light System with Adaptive High Beam Assist



3-spoke 12-button multi-function steering wheel with nappa leather trim, perforated in central grip area¹



Automatic climate control



Coupé-specific front seats



LED rear tail lights



Audio 20 radio with Bluetooth[®] interface



ECO start/stop function



USB port

¹Standard on AMG Sport and AMG Sport Plus only



Optional extras | Selection



Privacy glass – tinted rear side windows and rear windscreen



COMAND Online system with Linguatronic voice control



Media Interface



Panoramic glass sunroof



Lighting Package



Blind Spot Assist (part of Lane-Tracking Package)



Keyless-Go



C-Class Coupé Executive SE

The Executive SE exterior provides the perfect blend of sporty and dynamic driving pleasure with elegant and graceful design. Its front end features a sports grille with integrated star set within stylish bumpers. The Intelligent Light System with bi-xenon headlamps offers drivers the greatest possible view of the road, while the LED rear tail lights lend an eye-catching touch to the rear.



Exterior

16" alloy wheels – 7-spoke design

Bi-xenon headlamps with Intelligent Light System, LED daytime running lights and Adaptive High Beam Assist

LED rear tail lights

Parktronic with Advanced Parking Guidance

Sports grille with integrated star





The interior is upholstered in Artico,¹ which is complemented by a multi-function steering wheel and a nappa leather-trimmed gear shift, while the 6-disc CD changer and DAB digital radio tuner provide the perfect soundtrack to any journey.



Interior

Artico¹ upholstery

Audio 20 radio with 6-disc CD changer

Bluetooth[®] interface

Coupé-specific sports seats

DAB digital radio tuner

Split-folding rear seats

¹Artificial leather





Image shows optional panoramic sunroof



C-Class Coupé AMG Sport

The AMG Sport makes for a striking and involving C-Class Coupé. Its standard sports suspension and sports parameter steering (not available for C 180) increase your driving enjoyment, while the AMG styling enhancements add extra muscularity to the exterior. They include an AMG front apron, side skirts, a diffuser-style rear apron and 18" AMG 7-spoke alloy wheels.

Exterior

18" AMG alloy wheels – 7-spoke design

AMG bodystyling comprising front and rear aprons and side skirts

Cross-drilled front brake discs plus calipers with 'Mercedes-Benz' lettering

Electric power steering (C 180)

Lowered sports suspension

Parktronic with Advanced Parking Guidance

Sports parameter (speed-sensitive) steering (excluding C 180)

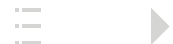



Image shows optional leather interior, comfort-ventilated seats, COMAND Online and Harman Kardon® Logic 7® surround sound system

The AMG Sport interior not only looks more dynamic, it feels it too. The flat-bottomed 3-spoke multi-function sports steering wheel is tactile and grippy, the black steering wheel gear shift paddles (automatic models only) offer racing-style gear changes. Other interior highlights include dark brushed aluminium trim, stainless steel sports pedals, a black roof lining and AMG floor mats, and there's also a large 4.5-inch colour display for the instrument panel.



Interior

3-spoke 12-button multi-function sports steering wheel with flat-bottomed rim and nappa leather trim, perforated central grip area

Attention Assist

AMG floor mats in black with 'AMG' insignia

Black roof lining

Steering wheel gear shift paddles in black (with automatic transmission)

DAB digital radio tuner and USB port

Dark brushed aluminium trim

Sports pedals in brushed stainless steel with rubber studs





C-Class Coupé AMG Sport Plus

The sporting hardware for this AMG Sport Plus has been carefully honed by AMG: AMG styling for front and rear aprons, side skirts, an AMG boot lid spoiler in body colour and exclusive bi-colour AMG alloy wheels in 7-twin-spoke design. Drilled front brake discs, brake calipers with 'Mercedes-Benz' lettering and tail pipes in polished stainless steel round off an already impressive Coupé.



Exterior

18" AMG bi-colour alloy wheels – 7-twin-spoke design

AMG boot-lid spoiler

AMG bodystyling – front apron, rear apron and side skirts

Brake calipers with 'Mercedes-Benz' lettering, drilled front brake discs, tail pipes in polished stainless steel

Electric power steering (C 180)

Sports suspension, lowered

Sports parameter (speed-sensitive) steering (excluding C 180)





An interior to please the most discerning: red decorative stitching on the AMG sports seats and steering wheel contrast with silver gear shift paddles on the 3-spoke multi-function sports steering wheel. Dark brushed aluminium decorative trim and black floor mats with 'AMG' insignia and red edging complete the interior, as well as the brushed stainless steel pedals.



Interior

3-spoke 12-button multi-function flat-bottomed sports steering wheel, nappa leather trim with contrasting red stitching and perforated central grip area

AMG floor mats in black with red edging

AMG sports seats with integral head restraints and individual seats in the rear

Attention Assist

Black roof lining

Centre console armrest, door centre areas and gear lever gaiter with red contrast stitching

Dark brushed aluminium trim

Instrument panel with high-resolution 4.5-inch colour display

Sports pedals in brushed stainless steel with rubber studs (also on parking brake pedal)

Steering wheel gear shift paddles in silver (automatic transmission only)

Upholstery in Black Artico¹/Dinamica microfibre or Black leather (option)

¹Artificial leather



Upholstery and trim - Executive SE



The standard Artico¹ upholstery features seats, lower dashboard and door centre panel are in Black. The A-, B- and C-pillar trims, upper dashboard and fabric roof lining are in black. There's additional High-Gloss Black trim for the dashboard, doors and centre console, with matt-finish Brown Ash wood available as an option.

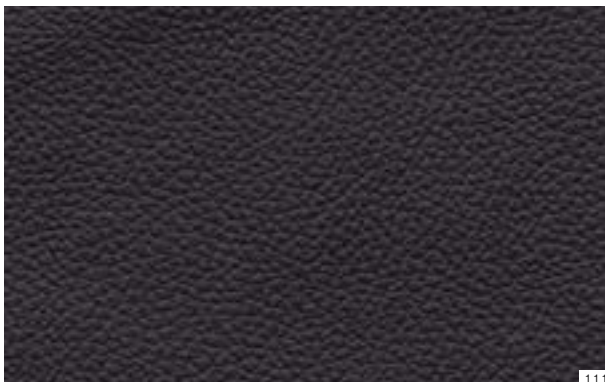

111



H80



H06

Black

111 Artico¹

Trim

H80 High-Gloss Black

H06 Brown Ash wood, matt finish²

¹Artificial leather ²Optional





Artico¹ artificial leather upholstery features seats, lower dashboard trim and door centre panel in Alpaca Grey. The A-, B- and C-pillar trims, upper dashboard and fabric roof lining are in black. There's additional High-Gloss Black trim for the dashboard, doors and centre console, with matt-finish Brown Ash wood available as an option.

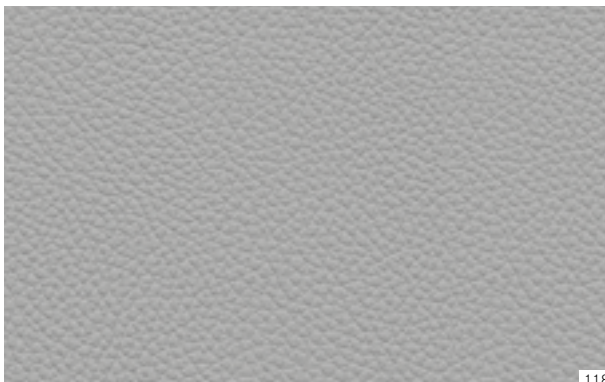

118



H80



H06

Alpaca Grey

118 Artico¹

Trim

H80 High-Gloss Black

H06 Brown Ash wood, matt finish²

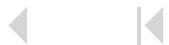
¹Artificial leather ²Optional

Upholstery and trim - AMG Sport



The standard Black interior with Artico¹/cloth upholstery features Black seats, a black dashboard and black door trims. The A-, B- and C-pillar trims and fabric roof lining are in black. There's additional dark brushed aluminium trim for the dashboard, doors and centre console, with High-Gloss Black or matt-finish Brown Ash wood available as an option.



401

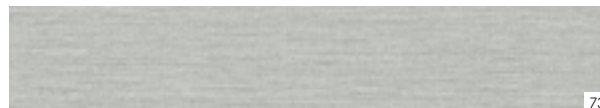

739



H80



H06

Black

401 Artico¹/cloth with contrast stitching

Trim

739 Dark brushed aluminium

H80 High-Gloss Black²

H06 Brown Ash wood, matt finish²

¹Artificial leather ²Optional

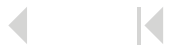



The standard Alpaca Grey interior with Artico¹/cloth upholstery features Alpaca Grey seats, a two-tone black and Alpaca Grey dashboard and a black fabric roof lining. There's also additional dark brushed aluminium trim for the dashboard, doors and centre console, with High-Gloss Black trim or matt-finish Brown Ash wood available as an option.



458

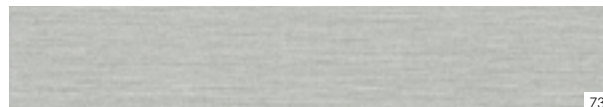

739



H80



H06

Alpaca Grey

458 Artico¹/cloth with contrast stitching

Trim

739 Dark brushed aluminium

H80 High-Gloss Black²

H06 Brown Ash wood, matt finish²

¹Artificial leather ²Optional





The optional Black interior with leather upholstery features Black leather seats with Dark Alpaca Grey top-stitching, black doors and dashboard. The A-, B- and C-pillar trims, fabric roof lining and load compartment cover are all in black. There's additional dark brushed aluminium trim for the dashboard, doors and centre console, with High-Gloss Black trim or matt-finish Brown Ash wood available as an option.

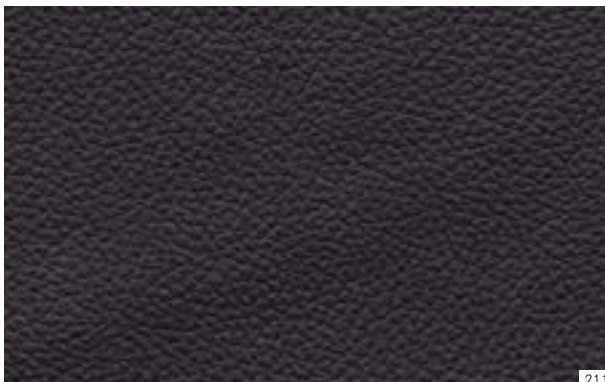

211

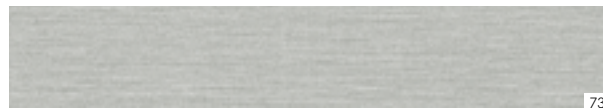

739



H80



H06

Black

211 Leather¹

Trim

739 Dark brushed aluminium

H80 High-Gloss Black¹H06 Brown Ash wood, matt finish¹¹Optional



The optional Alpaca Grey interior with leather upholstery features Alpaca Grey leather seats with Dark Alpaca Grey top-stitching, Alpaca Grey doors and a two-tone Black and Alpaca Grey dashboard. The A-, B- and C-pillar trims, fabric roof lining and load compartment cover are all in black. There's additional dark brushed aluminium trim for the dashboard, doors and centre console, with High-Gloss Black trim or matt-finish Brown Ash wood available as an option.

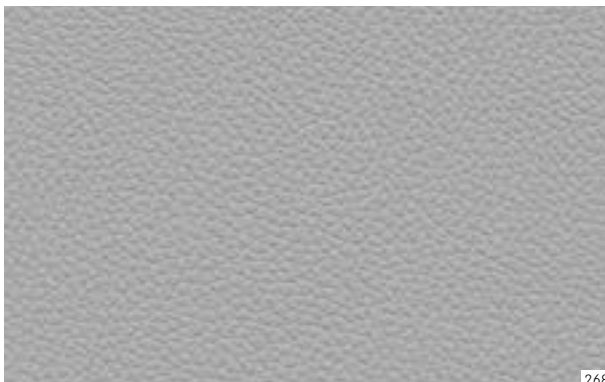

268

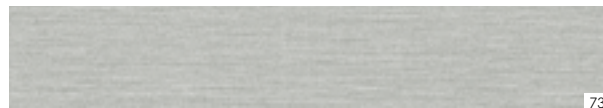

739



H80



H06

Alpaca Grey

268 Leather¹

Trim

739 Dark brushed aluminium

H80 High-Gloss Black¹H06 Brown Ash wood, matt finish¹¹Optional



The optional Sahara Beige interior with leather upholstery features Sahara Beige leather seats and top-stitching, with matching Sahara Beige door trim. The dashboard, fabric roof lining and load compartment cover are all in black, as are the A-, B- and C-pillar trims. There's additional dark brushed aluminium trim for the dashboard, doors and centre console, with High-Gloss Black trim or matt-finish Brown Ash wood available as an option.

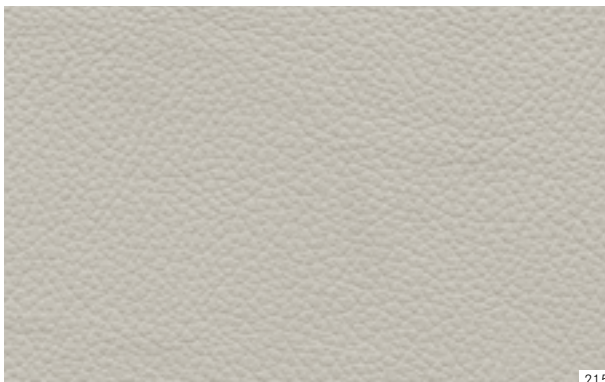

215

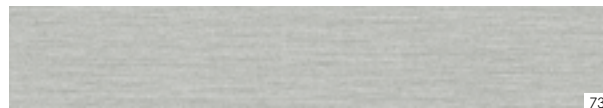

739



H80



H06

Sahara Beige

215 Leather¹

Trim

739 Dark brushed aluminium

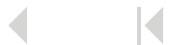
H80 High-Gloss Black¹H06 Brown Ash wood, matt finish¹¹Optional



The optional Bengal Red interior with leather upholstery features Bengal Red leather seats with black top-stitching and matching Bengal Red door trim. The dashboard, fabric roof lining and load compartment cover are all in black, as are the A-, B- and C-pillar trims. There's additional dark brushed aluminium trim for the dashboard, doors and centre console, with High-Gloss Black trim or matt-finish Brown Ash wood available as an option.



267

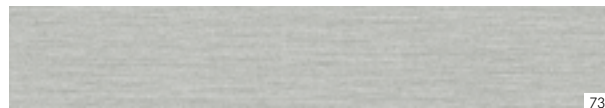

739



H80



H06

Bengal Red

267 Leather¹

Trim

739 Dark brushed aluminium

H80 High-Gloss Black¹H06 Brown Ash wood, matt finish¹¹Optional

Upholstery and trim - AMG Sport Plus



The standard Black interior with Artico/Dinamica¹ features a black dashboard, black door trim and a black load compartment cover. Red stitching features on the seats, dashboard, centre console, door centre areas and gear lever gaiter. Black nappa leather seat upholstery is available as an option. The A-, B- and C-pillar trims and fabric roof lining are in black. There's additional dark brushed aluminium trim for dashboard, doors and centre console.



741

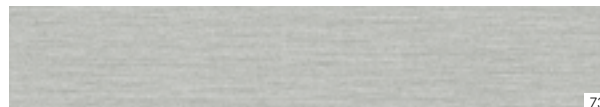

739



231

Black

741 Artico/Dinamica¹

231 Leather with red stitching²

Trim

739 Dark brushed aluminium

¹Artico artificial leather/Dinamica microfibre with red stitching ²Optional



Alloy wheels



16" AMG 7-spoke alloy wheels (standard on Executive SE, code R75)



18" AMG bi-colour alloy wheels - 7-twin-spoke design (standard on AMG Sport Plus, code 760)



18" AMG 7-spoke alloy wheels, painted black (optional on AMG Sport and AMG Sport Plus, code 661)



18" AMG 5-twin-spoke alloy wheels, with burnished Titanium Grey finish (optional on C 63 AMG, code 790)



18" AMG 7-spoke alloy wheels (standard on AMG Sport, code 782)



18" AMG 5-twin-spoke alloy wheels (optional on AMG Sport, code 786)



18" AMG 5-twin-spoke alloy wheels, with burnished Titanium Grey finish (standard on C 63 AMG, code 795)



19" AMG multi-spoke alloy wheels, with burnished Titanium Grey finish (optional on C 63 AMG, code 788)

Images show a selection of wheels. Please refer to the C-Class Coupé price list for a full list of available wheels



Retailer-fit accessories

A Mercedes-Benz is not just a car, it's a travel companion that can be tailored to your needs – with our wide range of Retailer-fit accessories.

→ www.mercedes-benz.co.uk/accessories

Our Retailer-fit accessories enable you to create the perfect C-Class Coupé for your lifestyle. If you often need to transport lots of luggage or sports gear, you'll find the ideal solution in our range of roof racks and boxes. The boxes come in two different sizes: the family version holds 450 litres while the sports box swallows 330 litres. Both open and close on either side and can be mounted on our Retailer-fit roof bars for safe and secure transportation.



Roof bars with 'Comfort' ski and snowboard rack

Also available are a luggage set and ski bags designed specifically to fit the roof boxes.

Add a sporty touch to your C-Class Coupé with an eye-catching Mercedes-Benz boot spoiler.

A very practical technical feature that puts your mind at rest is Tracker™. If your C-Class Coupé is ever stolen, VHF



Boot spoiler

(Very High Frequency) technology tracks your car's location – even if it's held in a garage or an underground car park.

For more details about these and other C-Class Coupé accessories, please see the relevant brochure or talk to your local Mercedes-Benz Retailer.



Tracker™

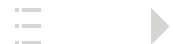



The Mercedes-Benz InCar Hotspot enables wi-fi Internet access



Services

Test drive. Words can only do so much. Some things have to be experienced to be truly appreciated. Which is why we'd like to invite you for a test drive. Feel the power of efficient engines that offer impressive fuel consumption. Feel exhilarated by precise steering, designed to connect the driver with the road and enjoy sumptuous levels of comfort. Your Mercedes-Benz Retailer will be happy to make arrangements for you to experience the things that set a Mercedes-Benz apart. Alternatively, to request a test drive online simply visit www.mercedes-benz.co.uk/testdrive
We look forward to seeing you.

Mercedes-Benz Finance. At Mercedes-Benz Finance, our single-minded aim is to provide optimum financial solutions for all those who share the Mercedes-Benz philosophy of absolute commitment to quality. Whether you are a private customer or a business user, our finance and leasing packages can be tailored to meet your individual needs. For further information on Mercedes-Benz Finance, please contact your local Mercedes-Benz Retailer.



Mercedes-Benz Insurance offers a fully comprehensive 5-star-rated¹ Motor Insurance policy specifically designed to provide the cover you would expect from Mercedes-Benz. For a quotation, please call 0845 600 2180?

Interactive Owner's Manual. The website also offers an interactive tour, enabling you to take a closer look at your desired model. This simulation is the ideal way to acquaint yourself with your dream car. You can view key functions in detail, gain an insight into the car's inner workings or look at the benefits of each model. For further details, visit www.mercedes-benz.co.uk/cclasscoupemannual



Roadside Assistance and Accident Management. Rest assured that should you ever need help, Mercedes-Benz Roadside Assistance is there for you. In the unlikely event of a technical breakdown³ you can rely on the Mercedes-Benz Roadside Assistance Team – anywhere in Europe. Mercedes-Benz will also assist you in the unfortunate event of an accident, from recovering your car and delivering it to your preferred Mercedes-Benz Retailer right through to managing your insurance claim in full, you will be looked after by the experts who built your Mercedes-Benz.⁴ Minor mishaps are also covered. Whether you lose your key, run out of fuel, or your vehicle is damaged due to vandalism, Mercedes-Benz ensures that you still reach your destination. Often the problem can be rectified on the spot, but if this is not possible, we will naturally ensure that your vehicle is taken to the nearest Mercedes-Benz Retailer to get you back on the road as quickly as possible.

¹As rated by Defaqto, a leading UK independent financial research company

²Mercedes-Benz Motor Insurance is underwritten by Aviva Insurance Limited. Calls are charged at local rate and may be recorded. We may decline to quote in some circumstances

Simply phone our Customer Assistance Centre on 00800 1 777 7777,⁵ where our specialists will organise assistance for you.

Service Care. To keep a tight grip on costs, Mercedes-Benz offers service plans to cover the costs of an annual service, for two, three and four years. Plans can be paid monthly with interest-free instalments or alternatively, if you pay upfront, should you sell your vehicle any remaining services will be transferred to the new owner. All routine maintenance and additional items are covered. To find out more, please contact your local Retailer or visit www.mercedes-benz.co.uk/servicecare

³Cover is initially valid for your vehicle for four years from the date of first registration. This can be extended from the fifth year, up to a maximum of 30 years, on completion of each scheduled maintenance service, providing that this service is carried out by a Mercedes-Benz

Mercedes-Benz World at Brooklands. Discover Mercedes-Benz racing heritage, from its connections to the famous Brooklands circuit through to present-day Formula 1™ brought to life in the most sensational way at Mercedes-Benz World in Surrey. View, touch and sit in every car from the Mercedes-Benz range, and encounter automotive legends like the ‘Gullwing’ and many other classic icons, in the UK’s largest Mercedes-Benz showcase. Then set your pulse racing by booking one of our thrilling Driving Experiences. Relax and refuel in Café 1886, or for something more enjoy the delicious menu and elegant surroundings of the Gullwing Restaurant. For more information, visit www.mercedes-benzworld.co.uk

Retailer. Minor mishap cover is provided at the absolute discretion of Mercedes-Benz

⁴Management of claims for non-fault accidents only

⁵In non-affiliated European countries: +44 20 7975 7077



Dimensions

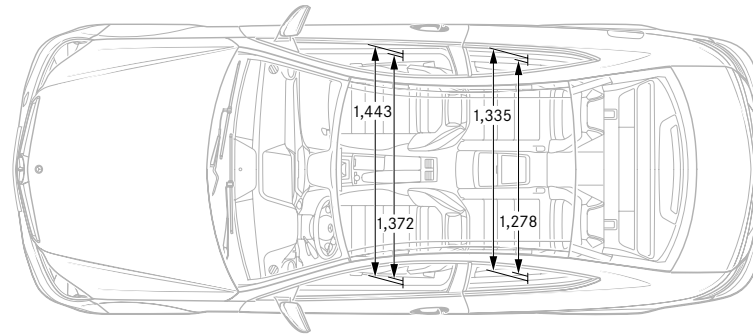
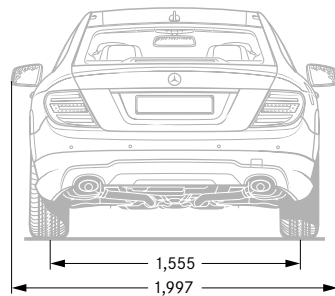
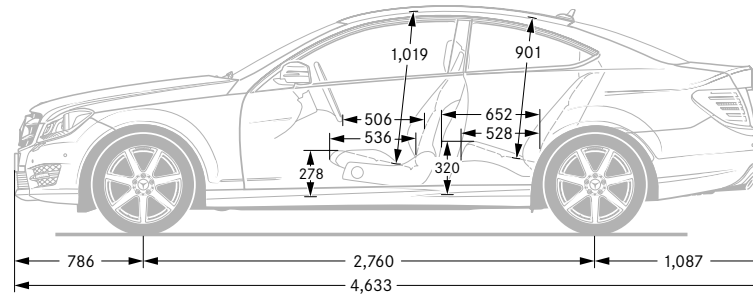
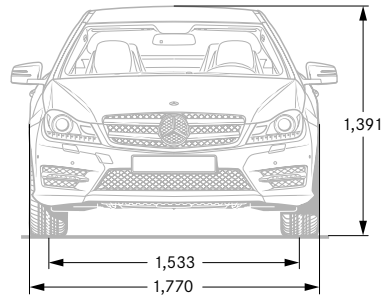

All measurements in millimetres. The dimensions shown are mean values and apply to standard-specification, unladen vehicles

¹Not available on C 63 AMG Edition 507

²Only available with AMG Handling Package (code P84) or C 63 AMG Edition 507



Technical data

	Diesel engines	
	C 220 CDI	C 250 CDI
Arrangement/cylinders/valves	in-line/4/16	in-line/4/16
Total displacement - cc	2,143	2,143
Rated output ¹ - hp (kW) at rpm	170 (125)/3,000-4,200	204 (150)/4,200
Rated torque ¹ - Nm at rpm	400/1,400-2,800	500/1,600-1,800
Acceleration 0-62 mph - sec (auto.)	8.4 (8.1)	7.0 (7.1)
Top speed approx. - mph (auto.)	144 (144)	149 (149)
Tyre size - front, rear	205/55 R 16, 205/55 R 16	225/40 R 18, 255/35 R 18
Fuel consumption ³ - mpg (auto.)		
Urban	54.3 (46.3)	41.5 (43.5)
Extra-urban	80.7 (67.3)	61.4 (61.4)
Combined	68.9 (57.7)	52.3 (53.3)
CO ₂ emissions, combined ³ - g/km (auto.)	109 (128)	143 (139)
EU emissions standard	EU5	EU5
Fuel tank capacity/reserve (approx.) - l	66/8	66/8
Boot capacity - l	450	450
Turning circle - m	10.84	10.84
Kerb weight ⁴ - kg	1,615 (1,630)	1,655 (1,660)
Perm. GVW - kg	2,085 (2,100)	2,125 (2,130)

¹Figures according to Directive 80/1269/EEC in the currently applicable version ²Electronically limited

³The figures shown were obtained in accordance with the prescribed measuring process (Directive 80/1268/EEC in the currently applicable version).

The figures are not based on an individual vehicle and do not constitute part of the product offer; they are provided solely for purposes of comparison between different vehicle models

⁴Figures according to Directive 92/21/EC, version 95/48/EC (kerb weight with fuel tank 90% full, driver, 68 kg, and luggage, 7 kg) for standard-specification vehicles. Optional extras and accessories will generally increase this figure and reduce the payload capacity accordingly

⁵With optional AMG Performance Package Plus Values in parentheses refer to engines with automatic transmission For more specifications, visit www.mercedes-benz.co.uk



	Petrol engines				
	C 180	C 250	C 350	C 63 AMG	C 63 AMG Edition 507
Arrangement/cylinders/valves	in-line/4/16	in-line/4/16	V/6/24	V/8/32	V/8/32
Total displacement – cc	1,595	1,796	3,498	6,208	6,208
Rated output ¹ – hp (kW) at rpm	156 (115)/5,300	204 (150)/5,500	306 (225)/6,500	457 (336)/6,800	507 (373)/6,800
Rated torque ¹ – Nm at rpm	250/1,250–4,000	310/2,300–4,300	370/3,500–5,250	600/5,000	610/5,200
Acceleration 0–62 mph – sec (auto.)	8.5 (8.5)	– (7.2)	– (6.0)	– (4.5)	4.2
Top speed approx. – mph (auto.)	140 (139)	– (149)	– (155) ⁵	– (155) ⁵	– (174) ⁵
Tyre size – front, rear	225/40 R 18, 255/35 R 18	225/40 R 18, 255/35 R 18	225/40 R 18, 255/35 R 18	235/40 R 18, 255/35 R 18	235/35 R 19, 255/30 R 19
Fuel consumption ² – mpg (auto.)					
Urban	34.9 (35.3)	– (31.0)	– (29.4)	– (15.5)	– (15.5)
Extra-urban	52.3 (53.3)	– (49.6)	– (50.4)	– (33.6)	– (33.6)
Combined	44.1 (44.8)	– (40.4)	– (40.4)	– (23.5)	– (23.5)
CO ₂ emissions, combined ² – g/km (auto.)	149 (147)	– (163)	– (164)	– (280)	– (280)
EU emissions standard	EU5	EU5	EU5	EU5	EU5
Fuel tank capacity/reserve (approx.) – l	66/8	66/8	66/8	66/14	66/14
Boot capacity – l	450	450	450	450	450
Turning circle – m	10.84	10.84	10.84	11.10	11.10
Kerb weight ³ – kg	1,490 (1,505)	– (1,550)	– (1,615)	– (1,730)	– (1,730)
Perm. GVW – kg	1,960 (1,975)	– (2,020)	– (2,085)	– (2,160)	– (2,160)

¹Figures according to Directive 80/1269/EEC in the currently applicable version ²Electronically limited

³The figures shown were obtained in accordance with the prescribed measuring process (Directive 80/1268/EEC in the currently applicable version).

The figures are not based on an individual vehicle and do not constitute part of the product offer; they are provided solely for purposes of comparison between different vehicle models

⁴Figures according to Directive 92/21/EC, version 95/48/EC (kerb weight with fuel tank 90% full, driver, 68 kg, and luggage, 7 kg) for standard-specification vehicles. Optional extras and accessories will generally increase this figure and reduce the payload capacity accordingly

⁵With optional AMG Performance Package Plus Values in parentheses refer to engines with automatic transmission For more specifications, visit www.mercedes-benz.co.uk



Paint finishes

The innovative Mercedes-Benz paint system features one of the finest clearcoats of any manufacturer. Its exceptionally dense molecular structure makes the paintwork more durable and lends it a deeper, more lasting sheen, helping your C-Class Coupé to retain both its looks and its long-term value.

Non-metallic paints (standard)

- 040 Black¹
- 149 Polar White
- 590 Fire Opal

Metallic paints (optional)

- 183 Magnetite Black¹
- 197 Obsidian Black
- 755 Tenorite Grey
- 775 Iridium Silver
- 792 Palladium Silver¹
- 890 Cavansite Blue¹
- 988 Diamond Silver¹

Special paints (optional)

- 051 *designo* Magno Platinum²
- 799 Diamond White metallic¹

¹Not available on C 63 AMG Edition 507

²Only available with AMG Handling Package (code P84) or C 63 AMG Edition 507

Non-metallic paints

040¹

149

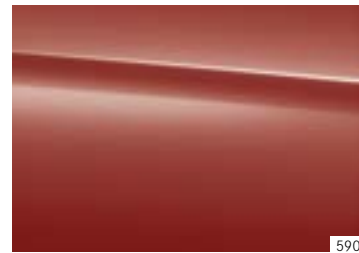

590

Metallic paints

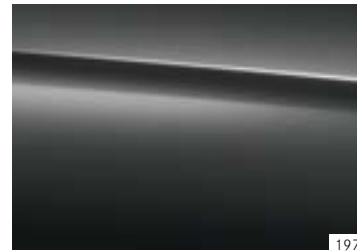
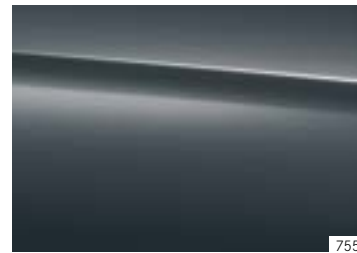
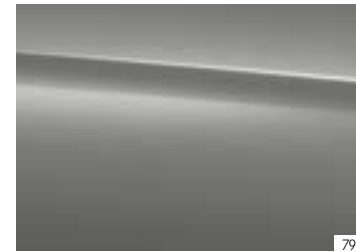
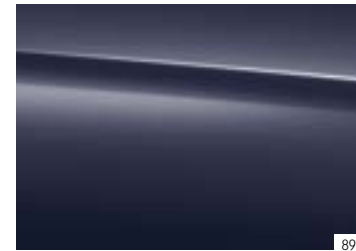
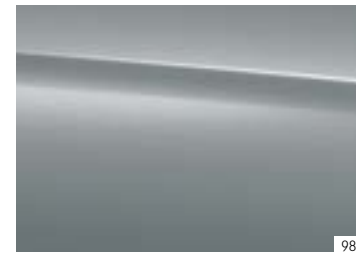
183¹197¹755¹775¹792¹890¹988¹

Special paints

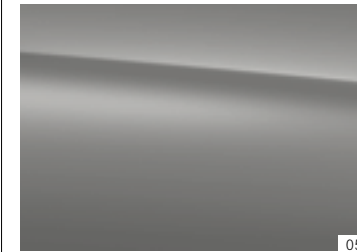
051¹799¹

Take-back of end-of-life vehicles. Coming full circle. At the end of its long life, you can return your C-Class to us for environment-friendly disposal in accordance with the EC End-of-Life Vehicle Directive!¹ But that day lies a long way off.

¹Applies in accordance with national regulations to vehicles up to 3.5 t permissible gross weight. The C-Class Coupé has met the statutory regulations governing the suitability of the vehicles' design for reuse and recycling for a number of years now. A network of vehicle take-back depots and dismantlers has been established which will process your vehicle in an environment-friendly manner. The ways in which both vehicles and parts can be recovered are subject to ongoing development and improvement. Consequently, the C-Class Coupé will be able to comply with any future increases in the recycling quota within the stipulated time limits. Further information is available at www.mercedes-benz.co.uk or call 0808 156 6606.

Please note: changes may have been made to the products since this brochure went to press (18.02.2013). The manufacturer reserves the right to make changes to the design, form, colour and specification during the delivery period, provided these changes, while taking into account the interests of the vendor, can be deemed reasonable with respect to the purchaser. Where the vendor or the manufacturer uses symbols or numbers to describe an order or the subject of an order, no rights may be derived solely from these. The illustrations may show accessories and items of optional equipment which are not part of standard specification. Colours may differ slightly from those shown in the brochure, owing to the limitations of the printing process. This brochure has been compiled by Daimler AG of Germany and is distributed internationally. It provides a general indication of the range of models, features, optional extras and/or colours available in various countries. Some of the models, features, optional extras and/or colours shown may not be available in your country or may only be available in a different specification. Additionally some models, features, optional extras and/or colours may only be available in combination with others. For current and more specific information in relation to the range of models, features, optional extras and/or colours available in your country, and their pricing, you should contact your nearest authorised Mercedes-Benz Retailer. www.mercedes-benz.co.uk

