

M-Class



Mercedes-Benz





First impressions

With the M-Class, you're always in control. It combines permanent four-wheel-drive stability with remarkable agility; gives you the power to make the most of both, on- or off-road; and features high-tech assistants that ensure you're prepared for whatever might lie ahead. The M-Class, though, is also about keeping resource use under control.

That's why its new-generation engines are not only more refined and more responsive, but more frugal and efficient too. In fact, with its combination of striking design, sporty character and go-anywhere ability, the only thing you might struggle to keep in check is your excitement.

[Overview](#) | [from page 4](#) [Insights](#) | [from page 12](#)

Featured models:
ML 250 BlueTEC AMG Sport Iridium Silver metallic front cover, pages 4 and 6 AMG 5-spoke alloy wheels, Black/Tobacco Brown leather upholstery and Brown Ash wood trim
ML 250 BlueTEC SE Diamond White metallic page 5 5-spoke alloy wheels, Artico upholstery and Brown Burr Walnut wood trim
ML 350 BlueTEC AMG Sport Diamond White metallic from page 8 AMG Sport interior, AMG 5-spoke alloy wheels, Artico artificial leather/Dinamica microfibre upholstery and brushed aluminium trim

Specifications shown may include optional equipment and accessories

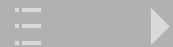
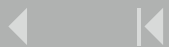

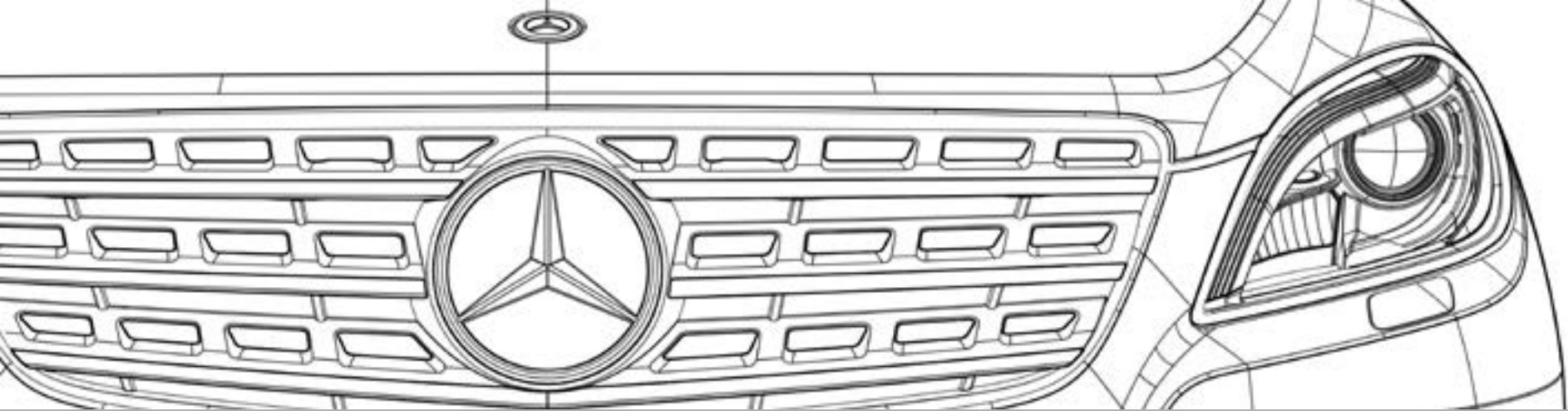

Facts

Efficiency and enjoyment: Mercedes-Benz Intelligent Drive, BlueEFFICIENCY, BlueTEC diesel engines, transmission, off-road systems and suspension.

Engines and suspension | from page 16

Integrated safety in the M-Class: safer driving, anticipating danger, protecting occupants and post-crash safety.

Safety | from page 26

Relaxation on or off road: seat comfort, climate control, cabin space, multimedia systems and electronic assistants.

Comfort | from page 30

Exclusivity and performance: ML 63 AMG exterior and interior, AMG Performance Package and AMG Performance Studio.

AMG | from page 36

Your personal M-Class: standard equipment and optional extras, M-Class SE exterior and interior, M-Class AMG Sport exterior and interior, upholstery and trim, alloy wheels and Retailer-fit accessories.

Equipment | from page 40

More Mercedes-Benz: test drive, Mercedes-Benz Finance and Insurance, Interactive Owner's Manual, Roadside Assistance and Accident Management, Service Care and Mercedes-Benz World.

Services | from page 56

M-Class in figures: dimensions, paint finishes and technical data.

Facts and finishes | from page 58



Ready for the road (or trail) ahead



Distinctive, dynamic, powerful and yet efficient: these were the qualities we aimed to instil in the M-Class. The goal was to produce a vehicle that would deliver on- and off-road enjoyment while treading rather more lightly on the planet. The result is an M-Class that's not just sportier and more muscular, but also cleaner and more frugal to boot.

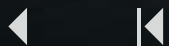

One efficiency drive that's not about constraints



In addition to generous levels of equipment, the M-Class also boasts an abundance of efficiency features. These features, part of our wide-reaching BlueEFFICIENCY drive, include low-resistance tyres, ECO start/stop and the standard 7G-Tronic Plus automatic transmission, whose electronics ensure you're always in the ideal gear for any situation. Proof that efficiency and unbridled enjoyment can go together after all.
→ pages 16-17



We've taken luxury
to new heights



Not even the wind can resist

Muscular yet elegant lines give the M-Class an unmistakable identity. The SE offers aluminium-style running boards and chrome-style underguards front and rear, while the AMG Sport features AMG bodystyling and privacy glass that serve to underline its sportier character. The sleek tail lights and rear apron ensure it's equally distinctive from behind. What's more, the design is not just aesthetic, it's also highly aerodynamic, with a class-leading drag coefficient that helps to further reduce fuel consumption.



Upgrade to M-Class



The stylish exterior promises much, and the sumptuous interior doesn't disappoint. Exceptional comfort has always been a hallmark of the M-Class, but now it's allied to sporty details and even more luxurious appointments. Sports seats, automatic climate control and the Easy-Pack powered tailgate are all fitted as standard on the AMG Sport, while the standard Becker® Map Pilot navigation system or the optional COMAND Online system puts map data, music and more at your fingertips – or, if you prefer, at your spoken command. → pages 31, 34



Keeps its feet firmly on the ground



Thanks to permanent four-wheel drive and 4ETS, torque and traction are impressive even on challenging surfaces. The Electronic Stability Programme (ESP®) helps to further enhance stability, while the optional On- & Off-Road Package and Active Curve System enable the M-Class to master even the toughest terrain. Wherever the journey takes you, you'll find the M-Class is ready and more than able. → pages 22-25





Blessed with a keen sense of danger

It isn't just the high driving position that makes you feel safer in an M-Class. It's also the many intelligent safety systems that work together to keep danger at bay. These include Attention Assist, a system that can detect signs of tiredness and recommend taking a break; Hill Start Assist, which can prevent the car from rolling backwards on inclines; and the Pre-Safe[®] system, whose sensors enable it to recognise potential accident scenarios and initiate anticipatory measures. What's more, the M-Class is also available with a range of optional safety aids that further enhance its ability to spot danger. → pages 26–29





Now every journey can
have a happy end



Why the M-Class always brings you down gently

What goes up must come down, as everyone knows. The real question is: how fast? In the M-Class, the answer is: at whatever pace you choose. Its patented Downhill Speed Regulation (DSR) makes light work of difficult descents (even 100% gradients), allowing you to set a constant, comfortably slow speed and use the cruise control lever to regulate the speed as required. As a result, it ensures a gentle and carefully controlled descent – rather like an electronic parachute.



When it comes to safety, no detail is too small

Over the last 50 or so years, countless lives have been saved thanks to a piece of steel no bigger than five centimetres. Patented by Mercedes-Benz way back in 1958, the wedge-pin door lock – consisting of a metal pin and two safety catches – prevented the doors flying open during an accident. Previously, this was a common and sometimes disastrous consequence of what should have been relatively harmless collisions.

But this five-centimetre lifesaver didn't only make passenger compartments safer. It also reduced the risk of doors jamming shut, giving emergency teams a greater chance of carrying out a swift rescue. Today, a more sophisticated version of the wedge-pin door lock remains the benchmark for door safety. It's another example of our long-standing commitment to occupant protection.

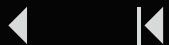

16 Mercedes-Benz Intelligent Drive**17 BlueEFFICIENCY****18 Diesel engines**

4-cylinder engine

V6 engine

20 Transmission

7G-Tronic Plus automatic transmission

Direct Select

22 Suspension

Permanent four-wheel drive

Off-road mode

Downhill Speed Regulation (DSR)

On- & Off-Road Package

Direct Steering

Active Curve System

Steel suspension with

Selective Damping System

AirMATIC air suspension

26 Integrated safety concept

Attention Assist

Intelligent Light System

Night View Assist Plus

Driving Assistance Package

Collision Prevention Assist

Pre-Safe® system

Active Bonnet

Restraint systems

Mercedes-Benz Emergency Call System

Rescue assistance

30 Seats

Electrically adjustable seats

Multi-contour seats with comfort

head restraints

31 Climate control

Automatic climate control

Luxury automatic climate control

Heated multi-function steering wheel

32 Load compartment

Easy-Pack load-securing kit

Easy-Pack powered tailgate

Additional load compartment options

34 Multimedia systems

COMAND Online system

Rear seat entertainment system

Bang & Olufsen BeoSound AMG

Becker® Map Pilot navigation system

35 Electronic assistants

Parktronic with Active Park Assist

Parking Package with 360° camera

Speed Limit Assist

36 ML 63 AMG exterior**38 ML 63 AMG interior****39 AMG Performance Package and Performance Studio**

40 Standard equipment**41 Optional extras****42 Model variants**

M-Class SE

M-Class AMG Sport

46 Upholstery and trim**52 Alloy wheels****54 Retailer-fit accessories****56 Services**

Test drive

Mercedes-Benz Finance and Insurance

Interactive Owner's Manual

Roadside Assistance and

Accident Management

Service Care

Mercedes-Benz World

58 Dimensions**59 Technical data****61 Paint finishes**

Mercedes-Benz Intelligent Drive – a new era in mobility

Our engineers focus on the future every day in order to make innovative technology a reality. This aspiration has resulted in developments with a lasting impact on automotive engineering. In other words, our work ensures that a Mercedes-Benz will always be ahead of its time.

We have developed one groundbreaking solution after another to get closer to realising our vision of safe and accident-free driving. Innovative technologies such as the Pre-Safe® anticipatory safety system and Distronic Plus radar-assisted cruise control first made it onto the road in a Mercedes-Benz, setting new standards in vehicle safety. It marked the first time active and passive systems were combined – for even better protection and ride comfort.

Mercedes-Benz Intelligent Drive takes things a step further by intelligently combining sensors with safety systems and electronic assistants. For us, it's a logical progression as the traffic situation has changed. There are more vehicles on the road, the driver's job is becoming more complex and distractions are increasing.

Once again, we have revolutionised the car to provide even more assistance and to help deal with road situations effectively: today, a Mercedes-Benz has an even greater spatial awareness. It has a better view of the road and other road users, and it can react to what it sees.

We have developed a stereo camera system that is capable of capturing three dimensions. Together with further sensors, this produces a 360° view – a precise image of the surroundings. If the safety systems and electronic assistants detect danger, they can respond within a fraction of a second to provide the driver with the right assistance for the situation in hand. For example, by performing an emergency braking manoeuvre in dangerous situations, or by dimming part of the main beam for the benefit of oncoming traffic.

Pioneer of innovation – Mercedes-Benz Intelligent Drive once again underlines our leading ambition and points the way ahead to accident-free and autonomous driving. The following pages include further information about our safety and comfort systems. They are available as standard equipment or optional extras for the M-Class, depending on the model specification. Further details can be found on pages 26–30 and 35.

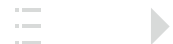

BlueEFFICIENCY in the M-Class

The M-Class combines power and performance with innovative BlueEFFICIENCY measures that help to optimise fuel economy and reduce CO₂ emissions.

Environmental protection and energy conservation are of ever increasing importance, with CO₂ emissions, fuel consumption and the cost of fuel all key issues for today's drivers. That's why we've equipped every M-Class with BlueEFFICIENCY technology.

As a result, the M-Class models deliver up to 12% more power than their equivalent predecessors, yet also manage to significantly reduce fuel consumption and emissions. In addition, the M-Class has been awarded the international 'Design for Environment' certificate

(ISO/TR 14062) in recognition of the environmental credentials of its entire lifecycle, from manufacturing to use to recycling.

BlueEFFICIENCY measures that feature in the M-Class:



- 1 Current fuel consumption display
- 2 Advanced BlueTEC diesel technology
- 3 Radiator shutters (not fitted to ML 63 AMG)
- 4 Fuel-efficient 7G-Tronic Plus automatic transmission
- 5 Aerodynamic optimisation (e.g. lowered suspension, underbody guard, roof and exterior mirror housings) for class-leading drag coefficient (ML 250 BlueTEC AMG Sport: 0.32)
- 6 ECO start/stop function as standard
- 7 Intelligent alternator management with brake energy recovery
- 8 Both BlueTEC diesel engines meet EU6 emissions standard
- 9 Energy-saving ancillary systems (fuel pump and electromechanical Direct Steering system)
- 10 Air-conditioning compressor only active on demand (except on ML 63 AMG)
- 11 Wheels and tyres designed for lower rolling resistance

Diesel engines

Cleaner, more economical and more powerful, the M-Class benefits from the latest Mercedes-Benz BlueTEC diesel technology. The refined engines are impressively torquey, yet deliver further reductions in fuel consumption and CO₂ emissions, while also meeting the EU6 standard for exhaust emissions.



The ML 250 BlueTEC engine combines pulling power with low fuel consumption

4-cylinder engine. The ML 250 BlueTEC 4-cylinder diesel, delivers 204 hp (150 kW) and 500 Nm of torque, gives you 44.8 mpg on the combined cycle and emits just 165 g/km of CO₂. This impressive blend of qualities is achieved thanks to a combination of advanced technologies. The latest-generation common-rail diesel system, for instance, features optimised combustion chambers, fast and precise injectors, and injection pressures of up to 2,000 bar, while two-stage turbocharging and high ignition pressures help to maximise torque at all engine speeds. For enhanced refinement, the engine is also fitted with counter-rotating balancer shafts.



V6 engine. The ML 350 BlueTEC offers a similarly impressive blend of efficiency and performance. Not only does it boast an output of 258 hp (190 kW) – that’s 12% more power than its predecessor – but its common-rail diesel V6 is also more fuel-efficient and easier on the environment. The combination of fast and precise piezo injectors, injection pressures of up to 1,600 bar and an optimised turbocharger help it to generate a mighty 620 Nm of torque, meaning outstanding pulling power in all situations, while also reducing combined fuel consumption by over 20%.

Both M-Class diesel engines already meet the emissions regulations of tomorrow (EU6), thanks to further improvements in our BlueTEC technology and diesel particulate filters that clean and treat the exhaust gases. In addition, they are equipped with the ECO start/stop function, which temporarily cuts the engine when the car is at a standstill; an intelligent alternator that enables kinetic energy to be recovered during coasting and braking; and a radiator shutter that reduces drag when the engine requires less cooling. Low-resistance tyres, on-demand ancillaries and improved aerodynamics help to further increase the vehicle’s overall efficiency.

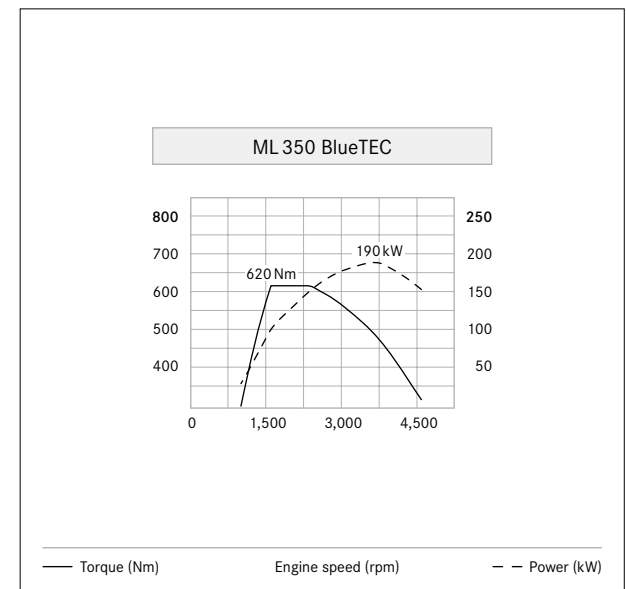

The ML 350 BlueTEC’s maximum 620 Nm of torque is available from just 1,600 rpm to 2,400 rpm



Transmission

The 7G-Tronic Plus 7-speed automatic transmission is perfectly matched to the M-Class engines and features ergonomic, intuitive controls.

7G-Tronic Plus (standard). 7G-Tronic Plus is the latest version of our 7-speed automatic transmission. Its seven forward gears ensure the engine is always operating at the optimum speed, helping to increase fuel efficiency, while the ECO start/stop function automatically cuts the engine when the car comes to a standstill, further reducing fuel consumption in urban driving. Optimised engine and transmission management software and an improved electro-hydraulic control unit deliver even sportier and smoother shifts, and make for faster responses to the accelerator pedal.

Direct Select (standard). The M-Class comes with our intuitive and ergonomic Direct Select steering column gear shift lever. Just tap the lever to switch between P, N, R and D and your input is transmitted electronically to the automatic transmission. Or, if you'd prefer to determine the shift points yourself, simply use the steering wheel gear shift paddles.



Transmission operation with the Direct Select lever - the driver can also control gear shift operation via the gear shift paddles on the steering wheel



7G-Tronic Plus: the result of more than 50 years' experience in automatic transmission technology



Suspension

The M-Class comes with permanent four-wheel drive as standard and offers a range of additional off-road systems. Together, they help to ensure excellent rough-terrain ability while also providing optimum stability on poor-quality roads.

Permanent four-wheel drive (standard). On- or off-road, the permanent four-wheel drive system offers dynamic handling and optimum stability. Being always on, it is able to respond almost instantaneously in the wet or on ice or snow. It is ably assisted by the Electronic Stability Programme (ESP®) and the Four-Wheel Electronic Traction System (4ETS), which incorporates the anti-locking braking system (ABS) and Acceleration Skid Control (ASR). 4ETS directs the torque away from

any spinning wheels and towards those with better traction, allowing the car to pull away more smoothly and accelerate more powerfully, especially on poor surfaces. The four-wheel drive system renders conventional differential locks largely superfluous, the automatic braking inputs making it easier to move off on slippery terrain and improving stability during critical manoeuvres.

Off-road mode (standard on ML 350 BlueTEC SE and AMG Sport; not available on ML 250 BlueTEC SE, AMG Sport or ML 63 AMG). The off-road mode further enhances the off-road ability of your M-Class, making changes to the engine management and automatic transmission as well as to safety systems such as ABS, ESP® and 4ETS. It can be activated simply by pressing a button in the centre console.

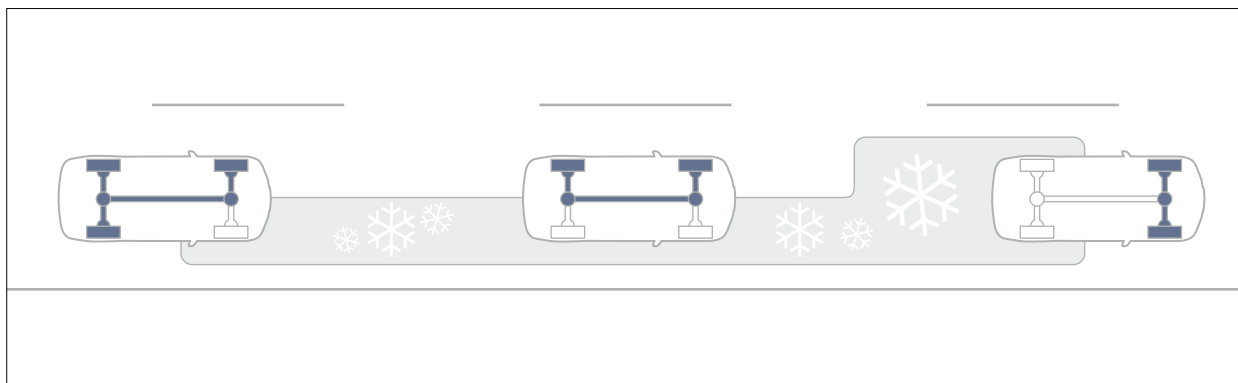

The Four-Wheel Electronic Traction System (4ETS) automatically transfers torque to the wheels with the most grip

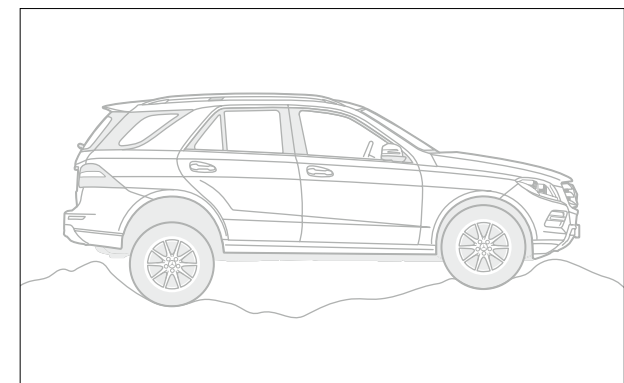

The M-Class performs on rough or smooth terrain



Downhill Speed Regulation (DSR) (standard). When the vehicle is negotiating steep downhill gradients, Downhill Speed Regulation allows the driver to set a speed of between 1.25 mph (2 km/h) and 11 mph (18 km/h). As far as is physically possible, the system then maintains the preset speed using the engine and transmission management and by applying the brakes as required. In this way, DSR makes for more relaxed descents and enhanced active safety in off-road driving.

On- & Off-Road Package (optional, only in conjunction with AirMATIC air suspension and COMAND Online; not available for ML 63 AMG). With the On- & Off-Road Package, you can tailor the car's set-up to suit the surface and situation by selecting one of six driving modes: 'Auto' (standard mode), 'Off-Road 1' (for sandy or less challenging terrain), 'Off-Road 2' (for rougher terrain), 'Sport', 'Snow' and 'Towing'. These preprogrammed modes alter the ESP®, 4ETS and ASR parameters, as well as the engine management, transmission and steering systems, and also adjust the air suspension, damping levels and ground

clearance as required. In 'Off-Road 2' mode, the AirMATIC air suspension allows for a ground clearance of 285 mm, while 'Sport' mode reduces the ride height to 180 mm at high speeds to ensure optimum agility and stability. The various modes are selected via a rotary switch in the centre console, with the current mode indicated on the COMAND Online display, along with animations showing the gradient and angle of inclination. The package also includes 100% centre differential locks,



The COMAND Online display shows the current driving mode along with the gradient and angle of inclination

a front underguard for the engine, and a reinforced guard for the entire underbody, which provides extra protection when off-roading. Other functions that can help to optimise off-road ability include a low-range ratio that enhances power, traction and stability when tackling unmade surfaces and the 7G-Tronic Plus transmission's manual mode.



The desired mode is selected via a rotary switch in the centre console

Direct Steering (standard). By adopting a more direct steering ratio in tight turns or when parking, Direct Steering significantly reduces the amount of steering input required and helps to give the M-Class the smallest turning circle in its class (11.8 metres). As your speed increases, the level of assistance decreases, helping to maximise straight-line stability in faster driving, while giving you more feel and greater precision. What's more, by only using energy when the situation requires, this electro-mechanical power steering system also helps to further reduce fuel consumption.

Active Curve System (optional on ML 350 BlueTEC SE and AMG Sport; not available for ML 250 BlueTEC SE and AMG Sport; standard on ML 63 AMG). With its active anti-roll bars, the Active Curve System minimises body roll when cornering and off-roading. This helps to improve off-road ability, while also enhancing enjoyment and comfort on country roads and increasing straight-line stability at motorway speeds.

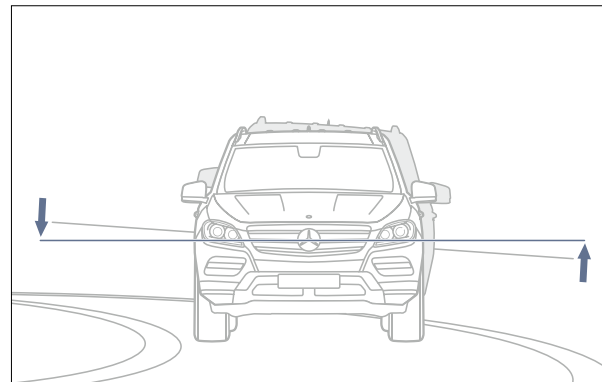

The Active Curve System keeps body roll to a minimum and increases ride comfort, agility and safety

Steel suspension with Selective Damping System

(standard on ML 250 BlueTEC and ML 350 BlueTEC). Thanks to steel suspension with Selective Damping System, the M-Class benefits from even better handling and ride comfort than earlier models, together with lower levels of noise and vibration. The Selective Damping System automatically adjusts the damping as you drive, helping to improve shock absorption and stability, especially on uneven surfaces. Featuring weight-saving aluminium components, the double-wishbone front suspension works in harmony with the sophisticated four-link rear axle to optimise comfort and handling both on and off road.

AirMATIC air suspension (optional; standard on ML 63 AMG). By adjusting the damping to suit the road surface, driving style and vehicle load, AirMATIC's Adaptive Damping System enables it to provide even greater ride comfort and safety than a conventional steel spring system. AirMATIC also allows the driver to switch manually between sporty and comfort-biased settings and, thanks to independent self-levelling, ensures the car's ride height is unaffected by heavy loads. At high speeds, the ride height is lowered to 161 mm, increasing stability, reducing drag and thus improving fuel efficiency. Once your speed drops below 25 mph, the standard ride height is automatically reinstated. AirMATIC can also give you extra ground clearance at the touch of a button, allowing you to increase the ride height to 236 mm (or 266 mm if the On- & Off-Road Package is fitted) when tackling rough terrain.



AirMATIC air suspension offers improved safety and ride comfort with Adaptive Damping System and integrated self-levelling suspension

Integrated safety concept

Like all our passenger cars, the M-Class is built according to an integrated safety concept. It ensures the many passive and active protection systems work together to enhance safety in every situation – helping to bring our vision of accident-free driving another step closer.

As the inventor of the motor car, we feel a particular responsibility towards road safety. That's why we were the first manufacturer to develop an integrated safety concept that seamlessly combines a car's active and passive safety features, thus ensuring optimum all-round protection. This concept covers four different areas – safer driving, anticipating danger, protecting occupants and post-crash safety – and incorporates measures designed to maximise safety in every situation, by helping you to stay safe, alerting you to danger, and assisting you wherever possible. In addition, our unique Pre-Safe® anticipatory safety system recognises likely accident scenarios and takes steps that help to further enhance occupant protection. If a collision can't be avoided, intelligent passive safety systems help to provide protection where it's needed, while solutions that can minimise the consequences of an accident and facilitate emergency assistance are also a key part of this safety concept. A selection of these technologies for the phases 'safer driving', 'anticipating danger', 'protecting occupants' and 'post-crash safety' are presented on the following pages.

Safer driving: Attention Assist (standard). If it detects signs of tiredness, Attention Assist alerts the driver via visual and acoustic warnings and recommends taking a break. It monitors driver behaviour via an array of sensors and registers unexpected changes that may indicate drowsiness or concentration lapses. Particularly beneficial on long journeys, Attention Assist is an innovative system for detecting fatigue. Between speeds of approximately 50 and 110 mph, it assesses the driver's behaviour via an array of sensors and registers



If it detects signs of fatigue or concentration lapses, Attention Assist suggests taking a break

unexpected changes that may indicate tiredness or concentration lapses, such as involuntary movements of the steering wheel.

Safer driving: Intelligent Light System (optional; standard on ML 63 AMG). The Intelligent Light System comprises a variety of modes and functions: country mode, motorway mode, fog mode, cornering light function and the Active Light System for better visibility in bends. It also includes LED daytime running lights



Adaptive High Beam Assist automatically maximises the range of the headlamps, thereby improving visibility for the driver

and Adaptive High Beam Assist, which maximises the headlamps' range when no other road users are within sight, then automatically dips the beams if the lights of an oncoming vehicle are detected. The M-Class with On- & Off-Road Package and Intelligent Light System can be supplemented by a special off-road light. This system throws out a particularly wide, bright beam, which has been specially developed for use in rough terrain.



Night View Assist Plus helps drivers to spot pedestrians by highlighting them on the screen

Safer driving: Night View Assist Plus (optional).

This infrared camera system captures the entire area that would be illuminated on main beam and shows a black-and-white image on the COMAND Online display, giving you a clearer picture of what's ahead. In addition, it automatically picks out any pedestrians on the road, making them easier to spot than with the naked eye.

Safer driving: Driving Assistance Package (optional).

This package comprises a range of intelligent safety

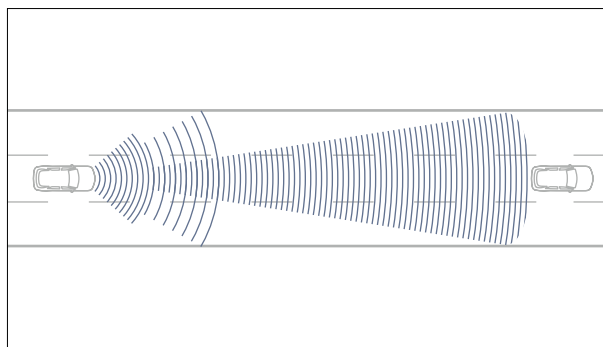

Active Lane-Keeping Assist alerts you to inadvertent lane changes and corrects the car's course if no action is taken

technologies. Active Lane-Keeping Assist draws the driver's attention to unintended lane changes, gently vibrating the steering wheel if the car wanders across lane markings. If the driver doesn't react to the warning, the system is able to intervene in order to correct the car's course. Active Blind Spot Assist makes intentional lane changes safer too, using twin radar sensors to watch over the areas not visible in your exterior mirrors. If the sensors spot a vehicle in one of these blind spots, a flashing red triangle appears in the corresponding mirror, accompanied by an acoustic warning from the instrument panel. Should the driver nevertheless proceed to change lanes, the system can intervene and help prevent a collision by automatically applying the brakes on the appropriate side. DISTRONIC Plus radar-assisted cruise control, meanwhile, enables the car to automatically maintain a preset distance from the vehicle in front, both in high-speed driving and in stop/start traffic. Also included in the package are our Brake Assist (BAS Plus) and Pre-Safe® Brake system – to give that feeling of safety on every trip.

Anticipating danger: Collision Prevention Assist (standard). Collision Prevention Assist can alert the driver if the distance to the vehicle in front decreases with unusual rapidity, thereby helping you to avoid front-end shunts. The radar-assisted warning system works from speeds around 20 mph. When the brakes are then applied, the Adaptive Brake Assist function can automatically increase the brake force if necessary, ensuring the available stopping distance is exploited to the full and thereby increasing the chances of avoiding an impact.

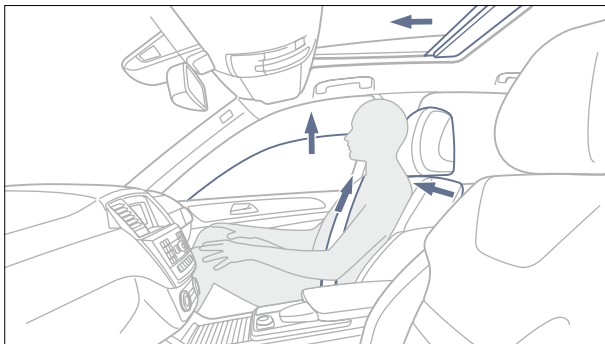

Pre-Safe® can recognise probable accident scenarios and initiate anticipatory measures that help to enhance occupant protection

Anticipating danger: Pre-Safe® system (standard). If it detects a probable accident scenario, Pre-Safe® anticipatory safety system can take a range of anticipatory measures to protect the occupants. These can include activating the front seat belt tensioners and automatically closing the windows and sunroof (if fitted), ensuring maximum protection from airbags and seat belts should an impact then occur. In addition, the optional memory function enables the front passenger seat to be moved to a safer position in an accident. If a collision is avoided, the seat belt tension is released, all other components can be returned to the desired positions, and the Pre-Safe® system reverts to standby.

Protecting occupants: Active Bonnet (standard; not available for ML 63 AMG). The Active Bonnet system can reduce the risk of injury to pedestrians and cyclists in a collision. If sensors in the front bumper detect an impact, they trigger a spring mechanism that raises the bonnet slightly. The extra space this creates between the comparatively soft bonnet and the hard components beneath can help to absorb some of the impact energy and thereby reduce the risk of severe injuries. After a collision, the Active Bonnet can be returned to its normal position by the driver.

Protecting occupants: restraint systems (standard). The 3-point seat belts, seat belt tensioners, belt force limiters and airbags are all carefully coordinated so as to keep injuries to a minimum. The M-Class is fitted with seven airbags to ensure optimum occupant protection, with dual-stage airbags for the front seats, sidebags (combined thorax/pelvis bags) for driver and front passenger, window bags over both rows of seats and a kneebag for the driver. If the crash sensors detect an impact, the seat belts are instantly tensed, helping to ensure the occupants remain firmly in their seats, while the belt force limiter relaxes the belt as the situation allows, in order to prevent undue force being applied to the rib cage.

Post-crash safety: Mercedes-Benz Emergency Call System (part of COMAND Online system). The system can automatically send an emergency call via an operational telephone connected to the vehicle, as soon as the restraint system detects a crash. The GPS position data and information about the car are sent to the Mercedes-Benz emergency call centre and a speech connection is then set up. The emergency call can also be triggered manually.

Post-crash safety: rescue assistance. Mercedes-Benz has developed a range of measures that help to minimise the secondary consequences of an accident and facilitate occupant rescue. These include automatic engine cut-off, self-activating hazard lights and emergency cabin lighting. In addition, the central locking system is automatically released in the event of an accident, and there are special crash joints between the front doors and wings that make it easier to open the doors after frontal collisions. In addition, Mercedes-Benz provides a rescue guide for emergency services that can be downloaded from the Internet at www.mercedes-benz.co.uk/rescueguide

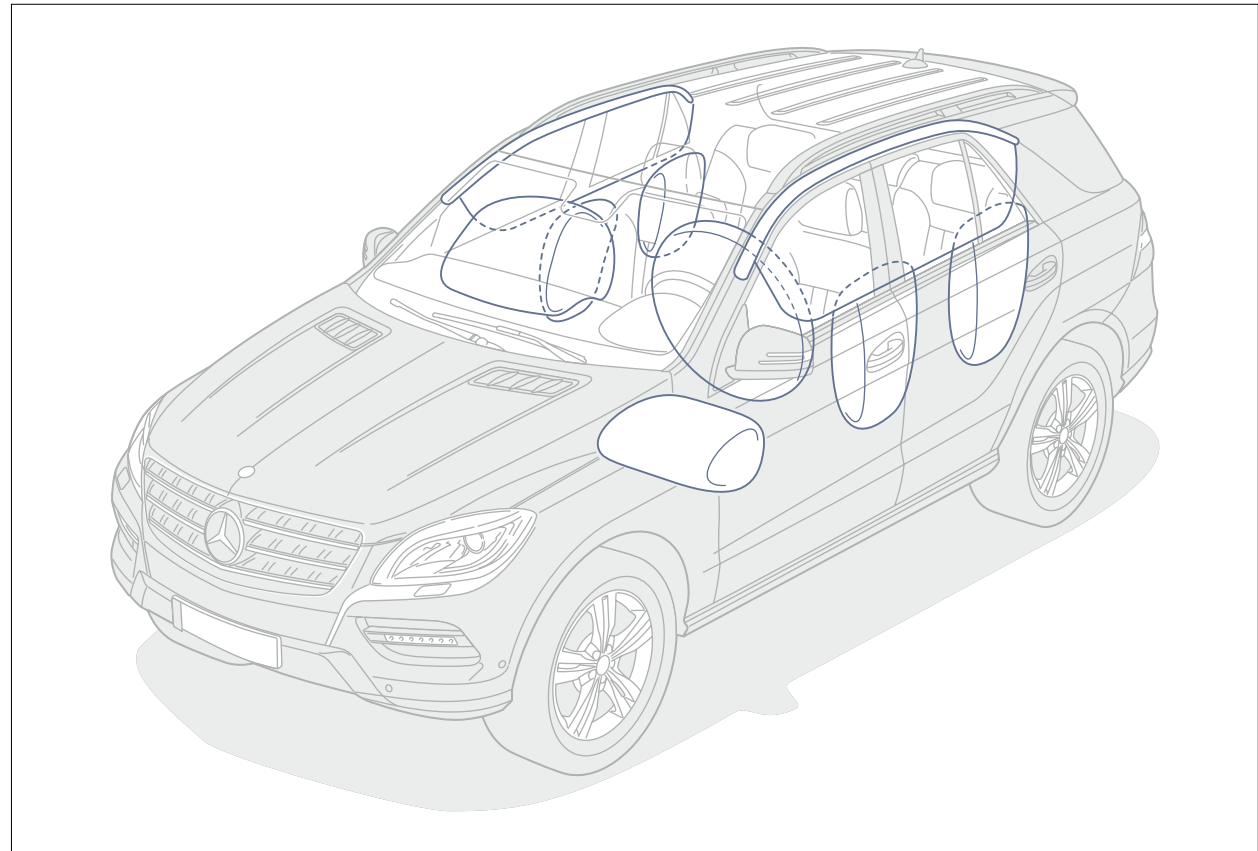

The standard safety features include airbags and sidebags for the driver and front seat passenger, windowbags for both rows of seats, and a driver's side kneebag

Seats

Front and rear, the M-Class offers exceptional long-distance comfort, optimum ergonomics and a commanding driving position.



The AMG Sport interior features sports seats upholstered in Black Artico¹/Dinamica microfibre

Electrically adjustable seats (standard). The standard SE seats are upholstered in Artico¹ with perforations in the seat centre panel, whilst AMG Sport seats are upholstered in Black Artico¹/Dinamica microfibre. The front seats feature full electric adjustment, with intuitive and conveniently positioned controls in the door panels, while rear seat passengers can also adjust the angle of their backrests. For the front seats there are the options of active multi-stage ventilation for cooler seat surfaces, and heating with three settings for the colder times of the year. An alternative option of heating without ventilation is available for all seats, front and rear. What's more, with their first-class materials and fine finishes, the M-Class seats not only offer excellent all-round comfort, they also lend the cabin an unmistakable air of quality.

Multi-contour seats with comfort head restraints (optional). Those who really love comfort can choose the multi-contour seats with massage function and comfort head restraints, making each journey more relaxing for driver and front passenger.

¹Artificial leather



Climate control

The right cabin climate makes for a relaxed, alert driver and contented passengers. Which is why the M-Class lets occupants choose their own individual temperature settings.

Automatic climate control (standard). Automatic climate control allows the driver and front seat passenger to select separate temperature and blower settings and maintains these settings automatically. It also includes an air recirculation function, a chilled glove compartment, twin air vents for the rear passenger compartment, and a cabin air filter that even captures particulates.

Luxury automatic climate control (optional). With luxury automatic climate control, the driver, front passenger and rear seat passengers can set separate temperatures for each of the three cabin zones. The system features separate controls and air vents and a booster blower for rear seat passengers, plus additional vents in the B-pillars, and offers individually adjustable settings even in automatic mode.

Heated multi-function steering wheel (optional). At the touch of a button, the rim of this steering wheel will heat up to a temperature of 35°C, making it a pleasure to hold even in cold weather. Together with features such as the optional temperature-controlled front cup holders, which offer a temperature range of between 8 and 55°C, it helps to ensure the M-Class offers maximum comfort and enjoyment whatever the season.



Intuitive, effective and easy to use, the luxury automatic climate control system responds rapidly to inputs and delivers draught-free heating and ventilation



The temperature-controlled cup holders keep hot drinks warm and cold drinks chilled, while also holding them securely in place



Load compartment

The M-Class seats up to five occupants, swallows long or bulky loads with ease and helps your cargo to stay securely in place throughout the journey.

All M-Class occupants enjoy generous leg, head and knee room, and there's ample space for elbows too. The spacious rear can even accommodate three child seats side by side, with the outer seats offering ISOFIX child seat anchorage points. Getting in and out couldn't be easier, thanks to extremely wide-opening doors, while the high, upright seating position means everyone can enjoy the view. Even with five occupants on board, the M-Class still offers some 690 litres of luggage capacity (measured up to top edge of rear backrest) or 1,025 litres if loaded to roof height. Should you require even more space, folding the $\frac{1}{3}:\frac{2}{3}$ split rear seat forward gives you a total luggage

capacity of 2,010 litres, a maximum load length of some 1.83 metres and an almost completely flat cargo area. For loose or awkward-shaped items, there are four load-securing rings on the load compartment floor, four bag hooks on the sides, and twin clothes hooks on the inside of the tailgate. The tailgate itself lifts to an impressive 1.99 metres from the ground (1.98 metres in the case of the ML 250 BlueTEC) when fully open, helping you to avoid knocks to the head when loading and unloading, while the stainless steel sill guard helps to protect the bumper and load compartment from scuffs and scratches.



The luggage capacity can be increased according to your needs



Three occupants and a 1.83-metre-long load area – just one of the numerous permutations



The load compartment of the M-Class is among the largest in its class

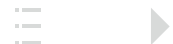
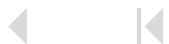

Easy-Pack load-securing kit (optional). The Easy-Pack load-securing kit helps to prevent your cargo from moving around during the journey and also makes for more convenient loading and unloading. It comprises twin load compartment rails on the left and right of the load compartment floor, plus a telescopic barrier that can be moved along the rails, dividing up the load compartment according to your needs and allowing bulky items to be fixed firmly in place. In addition, the kit includes a retractable luggage belt that enables awkward or round items to be secured to the sides of the load compartment.



The Easy-Pack load-securing kit makes for less strenuous loading and unloading

Easy-Pack powered tailgate (standard on AMG Sport and ML 63 AMG; optional on SE). The Easy-Pack powered tailgate can be operated remotely either via the switch in the driver's door or the remote control. It can also be opened by simply touching the tailgate handle, or manually using the external tailgate release, and closed by pushing a button on the inside of the tailgate. In addition, the tailgate can be stopped at any position, to prevent it from hitting a low garage ceiling for instance, and features an obstruction sensor which automatically reverses the direction of travel if it detects an obstacle.



The standard Easy-Pack powered tailgate

Additional load compartment options. The rear centre armrest can be fitted with an optional through-loading facility that is particularly useful for transporting skis.



The rear centre armrest with through-loading facility



Multimedia systems

The Audio 20 radio/CD and Becker® Map Pilot navigation systems come as standard, while options such as COMAND Online, the rear seat entertainment system and Bang & Olufsen BeoSound AMG help you and your passengers to get even more out of your M-Class.

COMAND Online system (optional; standard on ML 63 AMG). The multimedia system plays your audio and video DVDs, your CDs and even your MP3 files. It features a single CD player as well as a tuner, an equaliser with speed-sensitive volume adjustment, an SD card slot, Bluetooth® and a 10 GB music register that can be operated using a separate remote control. Also included are hard disk-based navigation with optimised map graphics and free European map updates for three years (for one vehicle from first registration) and in-car Internet access (Internet-enabled mobile phone needed). COMAND Online is

operated via an intuitive and easy-to-reach controller in the centre console, buttons on the multi-function steering wheel or Linguatronic voice control – with all the functions and information shown on the central 7-inch display.

Rear seat entertainment system (optional). The rear seat entertainment system gives rear seat passengers everything they need to watch films or use a games console without disturbing the driver. It comprises a DVD player, two 8-inch TFT colour displays that attach to the backs of the electric front seat head restraints and

can be used independently of one another, two sets of wireless headphones, a remote control and twin aux-in sockets. A TV tuner that brings broadcast television to the M-Class can be fitted as a separate option.

Bang & Olufsen BeoSound AMG (optional). You don't just hear the perfect acoustics of the Bang & Olufsen BeoSound AMG high-end sound system from the Danish specialist – you also see it; the 14 high-performance speakers with a total output of 1,200 watts combine outstanding technology and exclusive design. The grilles of the subwoofer in the parcel shelf and the mid-range and tweeter units in the front and rear doors are of solid brushed aluminium. And you hear a superlative sound stage that you would expect in a concert hall.

Becker® Map Pilot navigation system (standard¹). Becker® Map Pilot integrates with the Audio 20 radio/CD system's central controller and display, turning it into a fully featured navigation system. The control unit can be quickly secured and connected via a console in the glove compartment and removed at any time, while additional functions and map updates can be downloaded as required.



The COMAND Online system offers HDD navigation via a high-resolution 7-inch colour display

¹ ML 250 BlueTEC and ML 350 BlueTEC



The two displays for the rear seat entertainment system attach to the backs of the front seat head restraints



Electronic assistants

The M-Class offers a range of helpful assistants that make for more effortless driving and manoeuvring, helping to ensure your journey is as relaxing as possible.

Parktronic with Active Park Assist (standard on AMG Sport and ML 63 AMG; optional on SE). With Active Park Assist, your M-Class can identify suitable parking spaces and even manoeuvre itself into them. Once you've come to a standstill, accepted the proposed space and engaged reverse, the system steers you in automatically, leaving you to simply operate the accelerator, transmission and brakes as required. The system evaluates signals from Parktronic's ten ultrasonic sensors, using them to measure the distance to the vehicles in front and behind and thus calculate the ideal entry angle.

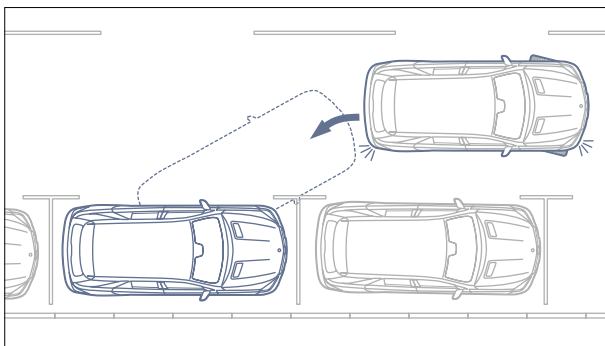

Active Park Assist completes the parking manoeuvre in a maximum of five moves

Parking Package with 360° camera (optional; only in conjunction with COMAND Online system). The Parking Package combines Parktronic with Active Park Assist and a 360° camera. Four cameras capture a 360° bird's eye view of the car's immediate surroundings and relay it to the centre console display. As a result, overall vision is highly improved off-road, and when parking and manoeuvring your M-Class. The system alerts the driver with visual and acoustic warnings. It also allows you to choose and separately display images of the individual cameras.



The 360° camera provides a bird's-eye view of the vehicle's immediate vicinity

Speed Limit Assist (part of the COMAND Online option). Thanks to a windscreen-mounted camera that permanently scans the car's surroundings, Speed Limit Assist can recognise speed limits and display them in the instrument panel. Particularly useful in areas where the legal limit varies or when passing through roadworks, the system is also able to compare speed limit signs with data from the navigation system.



Speed Limit Assist shows you the current legal limit on the instrument panel and in COMAND Online's central display



ML 63 AMG exterior

For car fans the world over, AMG means state-of-the-art technology, exclusivity and, above all, performance. The ML 63 AMG offers all three in abundance – along with a muscularity that's evident even at a standstill. → www.mercedes-benz.co.uk/amg



An exhilarating drive and a captivating sight, the ML 63 AMG combines personality, performance and outstanding versatility. Its muscular exterior boasts exclusive AMG styling enhancements, including 20 mm wider front wings with 'V8 BITURBO' badges, a gloss-black three-bar grille and dark-tinted headlamps, as well as an AMG front apron with LED daytime running lights and a matt chrome front underguard. At the rear, there's a model-specific AMG apron with chrome underguard and sporty chromed twin tailpipes left and right. Completing the muscular look are 20" 5-spoke alloy wheels in burnished Titanium Grey. They come fitted with 265/45 R 20 tyres and an AMG sports braking system featuring internally ventilated and drilled brake discs front and rear.

The ML 63 AMG gives you sports car performance – but with all the space and practicality of an M-Class



Under the skin, the ML 63 AMG boasts a biturbo AMG V8 that, together with the AMG Speedshift Plus 7-speed sports transmission, delivers sports-car performance combined with remarkable levels of efficiency. Despite generating an output of 525 hp (386 kW) and a maximum 700 Nm of torque, this high-tech engine succeeds in significantly reducing fuel consumption compared to its predecessor, thanks to the use of direct petrol injection, spray-guided combustion, twin turbochargers and intelligent alternator management. The transmission's Controlled Efficiency ('C') mode with start/stop function also helps to save fuel, while the Sport ('S') and Manual ('M') modes offer a noticeably more dynamic drive. Automatic throttle blipping and the AMG sports exhaust system's highly distinctive sound further add to your driving enjoyment. To ensure it's a pleasure in bends too, the ML 63 AMG also comes with exceptionally direct AMG sports parameter steering for enhanced high-speed cornering precision, and an AMG sports suspension with tauter springs, gas-pressure dampers and integral Active Curve System. Together with the two-stage

Electronic Stability Programme (ESP®), this AirMATIC-based suspension ensures optimum roadholding and a minimum of body roll.



Unmistakable presence: the ML 63 AMG never fails to turn heads

ML 63 AMG interior

Look beyond the ML 63 AMG's muscular exterior and you'll find a cabin that combines quality materials, first-class finishes and a resolutely sporty look.



The ML 63 AMG shown here with optional *designo* Black Piano Lacquer trim

Climb aboard and the ML 63 AMG welcomes you with illuminated stainless steel sill panels featuring AMG lettering. Once inside, you and your front seat passenger will find yourselves in the comfortable embrace of AMG sports seats and surrounded by sumptuous leather upholstery. It comes in a choice of three single-tone colour schemes, with two-tone or *designo* leather available as an option. Artico¹ lines the top of the dashboard, as well as the door caps, armrests and door centre panels, while the AMG Performance steering wheel boasts nappa leather trim, perforated grip areas and aluminium AMG gear shift paddles. The generous standard equipment also includes luxury automatic climate control, the COMAND Online system and an electric glass sunroof, as well as AMG-specific details such as AMG stainless steel sports pedals with rubber studs, AMG floor mats, AMG backrest badges front and rear and an AMG instrument panel with colour display.

¹Artificial leather



AMG Performance Package and Performance Studio

With high-performance components and individual styling options, the AMG Performance Studio lets you create an even more exhilarating ML 63 AMG.

For an even sportier ML 63 AMG, simply select options from the AMG Performance Studio. They include burnished AMG 5-twin-spoke alloy wheels, finished in Titanium Grey and fitted with 295/35 R21 tyres, and an AMG Performance Package that raises the engine's output to 557 hp (410 kW) and boosts maximum torque to 760 Nm. In addition, the AMG Performance Package adds red AMG brake calipers, and an AMG Performance steering wheel.

For those who want yet more performance, there's the optional AMG Driver's Package, which lifts the electronically-limited top speed to 174 mph (includes attendance at an AMG 'Power & Passion' driving event). The AMG Performance Studio can even fulfil specific customer requests – for everything from personalised vehicles to genuine one-offs.



AMG Performance steering wheel



AMG 5-twin spoke alloy wheels finished in Titanium Grey



Red AMG brake calipers



Standard equipment | Selection



LED daytime running lights



Audio 20 radio/CD



Controls for electrically adjustable front seats



Attention Assist



Electric parking brake



Door sill panels with 'Mercedes-Benz' lettering



Automatic climate control



LED tail lights



Optional extras | Selection



Panoramic glass sunroof



Aluminium-finish running boards (AMG Sport only)



Harman Kardon® Logic 7® surround sound system



Night View Assist Plus



Ambient interior lighting

¹Part of the optional Driving Assistance Package



Keyless-Go



Tow bar



Active Lane-Keeping Assist¹



M-Class SE exterior

The powerful beauty that is the M-Class SE.



19" 5-spoke alloy wheels, 255/50 tyres

There's little chance of the M-Class SE going unnoticed. Along with aluminium finish running boards, complete with rubber studs, the SE is equipped with chrome-style underguards in the front and rear bumpers. LED daytime running lights are standard, as are 19" 5-spoke alloy wheels. The SE also comes with a Mirror Package that includes electrically folding exterior mirrors as well as auto-dimming rear-view and driver's side mirrors.



Stainless steel-finish simulated underguard



M-Class SE interior

Bursting with more of the best.



M-Class SE shown with optional Almond Beige leather upholstery

Inside, brushed light aluminium trim is standard, with four different wood trims available as options. Seats are upholstered in Artico artificial leather with perforations in the seat centre panel in either Black, Almond Beige or Alpaca Grey, with optional leather also available. Front seats offer full electric adjustment and the driver's seat provides electric, four-way lumbar support. The nappa leather-trimmed multi-function steering wheel brings the Audio 20 under the driver's effortless control. Wherever you venture, it's reassuring to know that you can rely on the Becker® Map Pilot navigation system, fitted as standard.



Controls for the electrically-adjustable mirrors

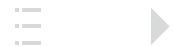

M-Class AMG Sport exterior

AMG bodystyling and AMG alloy wheels lend the M-Class Sport its athletic stance.



19" AMG 5-spoke alloy wheels (standard)

The AMG Sport features an even sleeker, sportier look with its AMG styling enhancements. It comes with 19" AMG 5-spoke alloy wheels with 255/50 R19 tyres as standard, as well as AMG bodystyling comprising striking front and rear aprons and body-coloured side skirts. The standard sports braking system with drilled front discs and caliper covers, meanwhile, ensures the stopping power is similarly muscular.



Rear bumper with integral AMG apron



M-Class AMG Sport interior

The dynamic nature of the M-Class is as evident inside as out, thanks to an AMG Sport interior that comes as standard.



The standard-specification AMG Sport interior comes with sports seats and Black Artico¹/Dinamica micro-fibre upholstery with distinctive ribbing and contrast top-stitching. Also fitted as standard are a 4-spoke sports steering wheel with perforated grip areas, rubber-studded stainless steel sports pedals, black floor mats with leather edging and Mercedes-Benz badges. The AMG Sport interior can also be specified with optional leather/nappa leather upholstery.²



The 4-spoke sports steering wheel with perforated grip areas

¹Artificial leather

²The standard AMG Sport interior features Artico artificial leather/Dinamica microfibre upholstery. When choosing optional leather upholstery, the interior differs from the standard specification AMG Sport interior. The 4-spoke steering wheel, seats and door centre panels are in a different design; the sports pedals are replaced and the 'Mercedes-Benz'-badged floor mats removed. The exception to this is if Black leather/nappa leather (code 801) is selected, in which case the AMG Sport interior remains unchanged



Upholstery and trim



The SE interior offers Artico¹ as standard (leather is optional), with brushed light aluminium trim. For the AMG Sport, the Black interior scheme is available with either standard Artico¹/Dinamica microfibre upholstery or optional leather/nappa leather. It features Black sports seats with contrasting top-stitching, Black door centre panels, carpets, dashboard and steering wheel trim, and comes with a roof lining in contrasting Alpaca Grey. Brushed aluminium interior trim comes as standard, while a variety of optional wood trims are also available.

Black

- 101 Artico^{1,2} (with perforations in seat centre panel)
- 601 Artico¹/Dinamica microfibre³
- 201 | 801 Leather^{4,5,6}/Nappa leather⁶

Trim

- 739 Brushed light aluminium^{2,3,4}
- 734 Brown Eucalyptus wood, gloss⁷
- 731 Brown Burr Walnut wood, gloss⁷
- 729 Anthracite Poplar wood, gloss⁷
- H09 Open-pore Brown Ash wood⁷

¹Artificial leather ²Standard on SE ³Standard on AMG Sport

⁴Standard on ML 63 AMG ⁵Optional on SE

⁶Optional on AMG Sport. When choosing optional leather upholstery for the AMG Sport, the interior differs from the standard specification AMG Sport interior. The 4-spoke steering wheel, seats and door centre panels are in a different design; the sports pedals are replaced and the 'Mercedes-Benz'-badged floor mats removed. The exception to this is if Black nappa leather (code 801) is selected, in which case the AMG Sport interior remains unchanged

⁷Additional-cost option

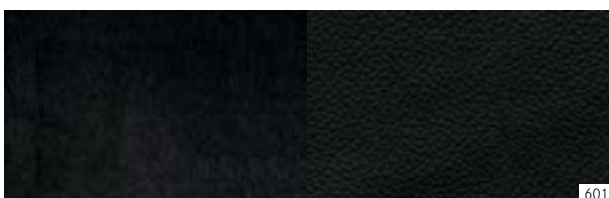

601

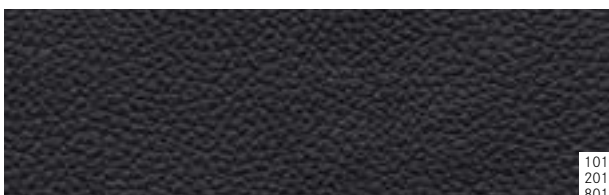
101
201
801

739



734



731



729



H09





The Alpaca Grey interior scheme comes with Alpaca Grey Artico^{1,2} (SE) or optional leather upholstery (SE and AMG Sport) for the seats and features matching Alpaca Grey for the door centre panels and roof lining. The carpets, upper dashboard trim and steering wheel are in contrasting Dark Basalt Grey. Brushed aluminium interior trim comes as standard, while a variety of optional wood trims are also available.

Alpaca Grey

108 Artico^{1,2} (with perforations in seat centre panel)

208 Leather^{3,4,5}

Trim

739 Brushed light aluminium^{2,3,6}

734 Brown Eucalyptus wood, gloss⁷

731 Brown Burr Walnut wood, gloss⁷

729 Anthracite Poplar wood, gloss⁷

H09 Open-pore Brown Ash wood⁷

¹Artificial leather ²Standard on SE ³Standard on ML 63 AMG ⁴Optional on SE
⁵Optional on AMG Sport. When choosing optional leather upholstery for the AMG Sport, the interior differs from the standard specification AMG Sport interior. The 4-spoke steering wheel, seats and door centre panels are in a different design; the sports pedals are replaced and the 'Mercedes-Benz'-badged floor mats removed. The exception to this is if Black nappa leather (code 801) is selected, in which case the AMG Sport interior remains unchanged
⁶Standard on AMG Sport ⁷Additional-cost option



108

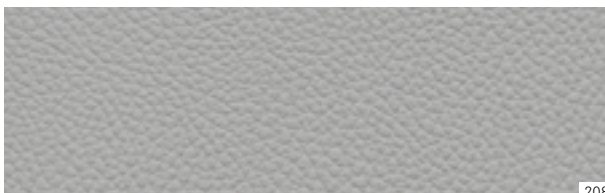

208



739



734



731



729



H09





The Almond Beige interior scheme comes with Almond Beige Artico¹ (SE) or optional leather upholstery (SE and AMG Sport) for the seats and features matching Almond Beige for the door centre panels, carpets and roof lining. The upper dashboard trim and steering wheel are in contrasting Mocha Brown. Brushed aluminium interior trim comes as standard, while a variety of optional wood trims are also available.

Almond Beige

105 Artico^{1,2} (with perforations in seat centre panel)

205 Leather^{3,4,5}

Trim

739 Brushed light aluminium^{2,3,6}

734 Brown Eucalyptus wood, gloss⁷

731 Brown Burr Walnut wood, gloss⁷

729 Anthracite Poplar wood, gloss⁷

H09 Open-pore Brown Ash wood⁷

¹Artificial leather ²Standard on SE ³Standard on ML 63 AMG ⁴Optional on SE
⁵Optional on AMG Sport. When choosing optional leather upholstery for the AMG Sport, the interior differs from the standard specification AMG Sport interior. The 4-spoke steering wheel, seats and door centre panels are in a different design; the sports pedals are replaced and the 'Mercedes-Benz'-badged floor mats removed. The exception to this is if Black nappa leather (code 801) is selected, in which case the AMG Sport interior remains unchanged
⁶Standard on AMG Sport ⁷Additional-cost option



105

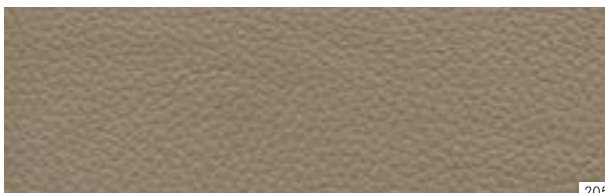

205



739



734



731



729



H09





The optional Black/Alpaca Grey interior scheme comes with Alpaca Grey leather upholstery for the seats and features matching Alpaca Grey door centre panels. The carpets, roof lining, upper and lower dashboard trim and steering wheel are in contrasting black. Brushed aluminium interior trim comes as standard, while a variety of optional wood trims are also available.

Black/Alpaca Grey

258 Leather¹

Trim

739 Brushed light aluminium²

734 Brown Eucalyptus wood, gloss³

731 Brown Burr Walnut wood, gloss³

729 Anthracite Poplar wood, gloss³

H09 Open-pore Brown Ash wood³

¹Additional-cost option for AMG Sport and ML 63 AMG. When choosing optional leather upholstery for the AMG Sport, the interior differs from the standard specification AMG Sport interior. The 4-spoke steering wheel, seats and door centre panels are in a different design; the sports pedals are replaced and the 'Mercedes-Benz'-badged floor mats removed. The exception to this is if Black nappa leather (code 801) is selected, in which case the AMG Sport interior remains unchanged

²Standard ³Additional-cost option

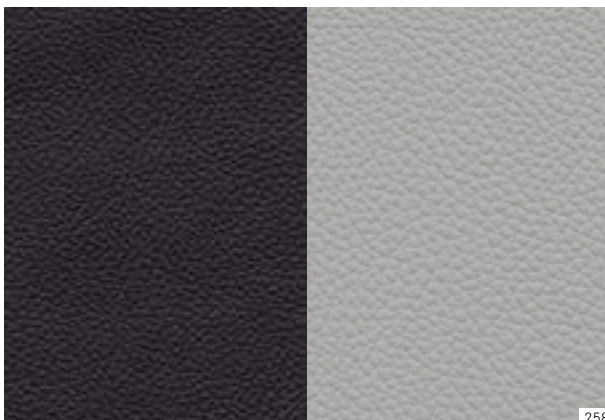



The optional Black/Almond Beige interior scheme comes with Almond Beige leather upholstery for the seats and features matching Almond Beige door centre panels. The carpets, roof lining, upper and lower dashboard trim and steering wheel are in contrasting black. Brushed aluminium interior trim comes as standard, while a variety of optional wood trims are also available.

Black/Almond Beige

255 Leather¹

Trim

739 Brushed light aluminium²

734 Brown Eucalyptus wood, gloss³

731 Brown Burr Walnut wood, gloss³

729 Anthracite Poplar wood, gloss³

H09 Open-pore Brown Ash wood³

¹Additional-cost option for AMG Sport and ML 63 AMG. When choosing optional leather upholstery for the AMG Sport, the interior differs from the standard specification AMG Sport interior. The 4-spoke steering wheel, seats and door centre panels are in a different design; the sports pedals are replaced and the 'Mercedes-Benz'-badged floor mats removed. The exception to this is if Black nappa leather (code 801) is selected, in which case the AMG Sport interior remains unchanged

²Standard ³Additional-cost option

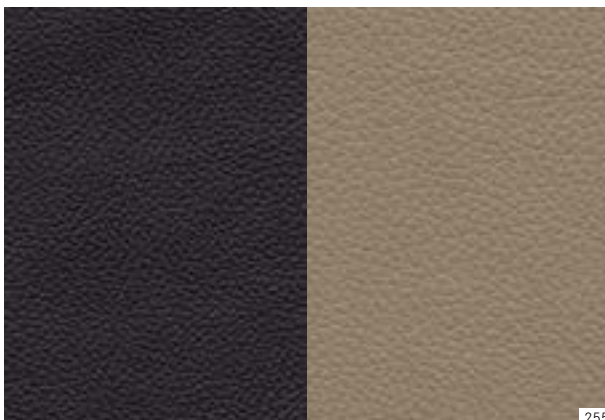



The optional Black/Tobacco Brown interior scheme comes with Tobacco Brown and Marron leather upholstery for the seats and features Marron door centre panels and armrests. The carpets, roof lining, upper and lower dashboard trim and steering wheel are in contrasting black. Brushed aluminium interior trim comes as standard, while a variety of optional wood trims are also available.

Black/Tobacco Brown

254 Leather¹

Trim

739 Brushed light aluminium²

734 Brown Eucalyptus wood, gloss³

731 Brown Burr Walnut wood, gloss³

729 Anthracite Poplar wood, gloss³

H09 Open-pore Brown Ash wood³

¹Additional-cost option for AMG Sport and ML 63 AMG. When choosing optional leather upholstery for the AMG Sport, the interior differs from the standard specification AMG Sport interior. The 4-spoke steering wheel, seats and door centre panels are in a different design; the sports pedals are replaced and the 'Mercedes-Benz'-badged floor mats removed. The exception to this is if Black nappa leather (code 801) is selected, in which case the AMG Sport interior remains unchanged

²Standard ³Additional-cost option

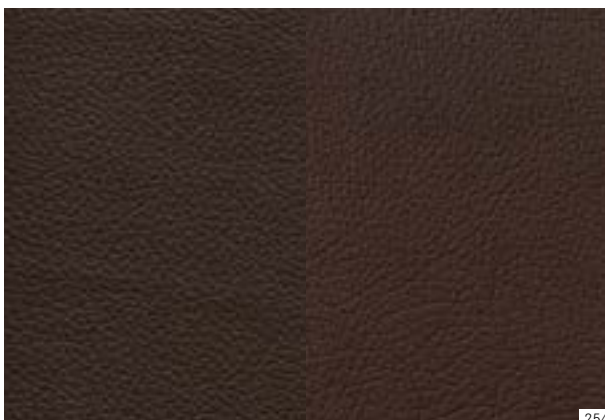

Alloy wheels



21" AMG 5-twin-spoke alloy wheels (code 757: optional for AMG Sport; not available for SE or ML 63 AMG)





17" 10-spoke alloy wheels (optional for SE only, code 25R)



19" 7-spoke alloy wheels (optional for SE only, code R53)



20" 5-twin-spoke alloy wheels (optional for SE only, code R33)



20" AMG 5-spoke alloy wheels (standard for ML 63 AMG only, code 778)



19" 5-spoke alloy wheels (standard on SE, code R39) – not available for AMG Sport or ML 63 AMG



19" AMG 5-spoke alloy wheels (standard on AMG Sport, code 780) – not available for SE or ML 63 AMG



20" AMG 5-spoke alloy wheels (optional for AMG Sport only, code 758)



21" AMG 5-twin-spoke alloy wheels (optional for ML 63 AMG only, code 798)



Retailer-fit accessories

A Mercedes-Benz is not just a car, it's a travel companion that can be tailored to your needs – with our wide range of Retailer-fit accessories.

→ www.mercedes-benz.co.uk/accessories

The iPad® docking station enables those in the rear to use Apple tablets as safely and comfortably as possible. Not only does it allow media stored on the iPad® to be enjoyed during the journey, it also charges the battery at the same time (available for iPad® or iPad 2®). What's more, with the Retailer-fit InCar Hotspot, even non-3G tablets can be connected to the Internet.



The rear seat docking station allows passengers to use and charge an iPad® at the same time

The bright chrome fins are a distinctive addition to the bonnet of the M-Class and blend harmoniously with its chrome exterior trim. Designed specifically for the M-Class bonnet vents, they come in a six-piece set that is quick and easy to fit.



The bright chrome bonnet fins are eye-catching and easy to fit

Another very practical feature that puts your mind at rest is our Tracker™. If your M-Class is ever stolen, VHF (Very High Frequency) technology tracks down your car's location – even if it's held in a garage or an underground car park.



Tracker™



The M-Class is a car for those who appreciate the luxury of space, be it for transporting people in comfort or for carrying all kinds of cargo. Should you need to transport even larger amounts of luggage, however, simply choose from the range of exceptionally durable Mercedes-Benz roof boxes. Available in a variety of different colours and sizes, they can be opened on either side for easy loading and unloading and have an aerodynamic design that perfectly matches the sporty M-Class lines. What's more, they can be attached quickly and easily to the lightweight aluminium roof bars – a Retailer-fit accessory designed specifically to fit the M-Class.



The M-Class roof boxes combine extra storage space with elegant, aerodynamic lines

Services

Test drive. Words can only do so much. Some things have to be experienced to be truly appreciated. Which is why we'd like to invite you for a test drive. Feel the power of efficient engines that offer impressive fuel consumption. Feel exhilarated by precise steering, designed to connect the driver with the road and enjoy sumptuous levels of comfort. Your Mercedes-Benz Retailer will be happy to make arrangements for you to experience the things that set a Mercedes-Benz apart. Alternatively, to request a test drive online simply visit www.mercedes-benz.co.uk/testdrive. We look forward to seeing you.

Mercedes-Benz Finance. At Mercedes-Benz Finance, our single-minded aim is to provide optimum financial solutions for all those who share the Mercedes-Benz philosophy of absolute commitment to quality. Whether you are a private customer or a business user, our finance and leasing packages can be tailored to meet your individual needs. For further information on Mercedes-Benz Finance, please contact your local Mercedes-Benz Retailer.



Mercedes-Benz Insurance offers a fully comprehensive 5-star-rated¹ Motor Insurance policy specifically designed to provide the cover you would expect from Mercedes-Benz. For a quotation, please call 0845 600 2180².

Interactive Owner's Manual. The website also offers an interactive tour, enabling you to take a closer look at your desired model. This simulation is the ideal way to acquaint yourself with your dream car. You can view key functions in detail, gain an insight into the car's inner workings or look at the benefits of each model. For further details, visit www.mercedes-benz.co.uk/mclassmanual.



Roadside Assistance and Accident Management. Rest assured that should you ever need help, Mercedes-Benz Roadside Assistance is there for you. In the unlikely event of a technical breakdown³ you can rely on the Mercedes-Benz Roadside Assistance Team – anywhere in Europe. Mercedes-Benz will also assist you in the unfortunate event of an accident, from recovering your car and delivering it to your preferred Mercedes-Benz Retailer right through to managing your insurance claim in full, you will be looked after by the experts who built your Mercedes-Benz⁴. Minor mishaps are also covered. Whether you lose your key, run out of fuel, or your vehicle is damaged due to vandalism, Mercedes-Benz ensures that you still reach your destination. Often the problem can be rectified on the spot, but if this is not possible, we will naturally ensure that your vehicle is taken to the nearest Mercedes-Benz Retailer to get you back on the road as quickly as possible.

¹As rated by Defaqto, a leading UK independent financial research company

²Mercedes-Benz Motor Insurance is underwritten by Aviva Insurance Limited. Calls are charged at local rate and may be recorded. We may decline to quote in some circumstances

Simply phone our Customer Assistance Centre on 00800 1 777 7777,⁵ where our specialists will organise assistance for you.

Service Care. To keep a tight grip on costs, Mercedes-Benz offers service plans to cover the costs of an annual service, for two, three and four years. Plans can be paid monthly with interest-free instalments or alternatively, if you pay upfront, should you sell your vehicle any remaining services will be transferred to the new owner. All routine maintenance and additional items are covered. To find out more, please contact your local Retailer or visit www.mercedes-benz.co.uk/servicecare

³Cover is initially valid for your vehicle for four years from the date of first registration. This can be extended from the fifth year, up to a maximum of 30 years, on completion of each scheduled maintenance service, providing that this service is carried out by a Mercedes-Benz

Mercedes-Benz World at Brooklands. Discover Mercedes-Benz racing heritage, from its connections to the famous Brooklands circuit through to present-day Formula 1™ brought to life in the most sensational way at Mercedes-Benz World in Surrey. View, touch and sit in every car from the Mercedes-Benz range, and encounter automotive legends like the ‘Gullwing’ and many other classic icons, in the UK’s largest Mercedes-Benz showcase. Then set your pulse racing by booking one of our thrilling AMG or 4 × 4 Driving Experiences. Relax and refuel in Café 1886, or enjoy the delicious menu and elegant surroundings of the Gullwing Bistro. For more information, visit www.mercedes-benzworld.co.uk

Retailer. Minor mishap cover is provided at the absolute discretion of Mercedes-Benz

⁴Management of claims for non-fault accidents only

⁵In non-affiliated European countries: +44 20 7975 7077



Dimensions

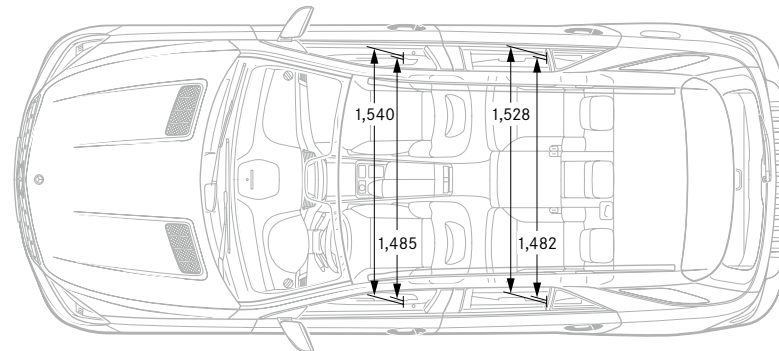
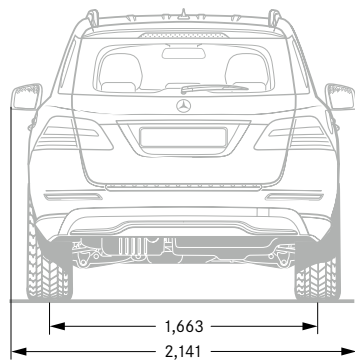
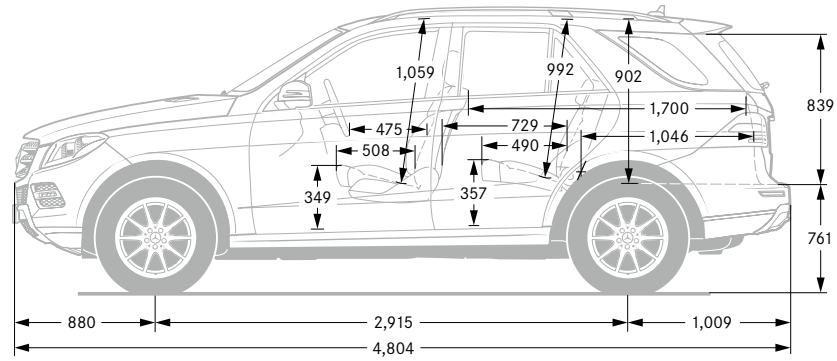
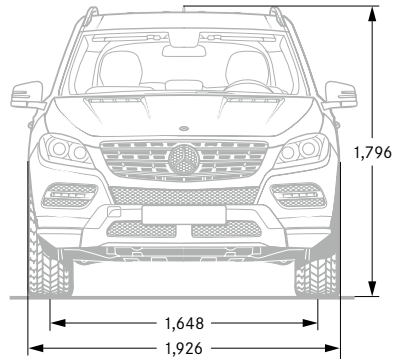

All measurements in millimetres. The dimensions shown are mean values and apply to standard-specification, unladen vehicles



Technical data

	Diesel engines	
	ML 250 BlueTEC	ML 350 BlueTEC
Arrangement/cylinders/valves	in-line/4/16	V/6/24
Transmission	7G-Tronic Plus	7G-Tronic Plus
Total displacement – cc	2,143	2,987
Rated output ¹ – hp (kW) at rpm	204 (150)/4,200	258 (190)/3,600
Rated torque ¹ – Nm at rpm	500/1,600–1,800	620/1,600–2,400
Acceleration 0–62 mph – sec	9.0	7.4
Top speed, approx. – mph	130	139
Tyre size	255/50 R19	255/50 R19
Fuel consumption ² – mpg		
Urban	38.7	34.4
Extra-urban	50.4	42.2
Combined	44.8	39.2
CO ₂ emissions, combined ² – g/km	170–158	194–179
Emissions standard	EU6	EU6
Fuel tank capacity/of which reserve – l	70/11	70/11
Boot capacity – l		
max. behind 1st row of seats	2,010	2,010
max. behind 2nd row of seats	690	690
Turning circle – m	11.80	11.80
Kerb weight ³ /Perm. Gross Vehicle Weight – kg	2,150/2,950	2,175/2,950
Towing capacity, braked/unbraked – kg	2,950/750	3,500/750

¹ Figures in accordance with Directive 80/1269/EEC in the currently applicable version ² The figures shown were obtained in accordance with the prescribed measuring process (Regulation [EC] 715/2007 in the currently applicable version).
The figures are not based on an individual model and do not constitute part of the product offer; they are provided solely for purposes of comparison between different vehicle models



	Petrol engine
	ML 63 AMG
Arrangement/cylinders/valves	V/8/32
Transmission	AMG Speedshift Plus 7G-Tronic
Total displacement – cc	5,461
Rated output ¹ – hp (kW) at rpm	525 (386)/5,250–5,750 [557 (410)/5,250–5,750 ⁴]
Rated torque ¹ – Nm at rpm	700/1,750–5,000 [760/2,000–5,000 ⁴]
Acceleration 0–62 mph – sec	4.8 [4.7 ⁴]
Top speed, approx. – mph	155 ⁵ [174 ⁶]
Tyre size	265/45 R 20 with 9J × 20 ET41
Fuel consumption ² – mpg	
Urban	18.0
Extra-urban	29.4
Combined	23.9
CO ₂ emissions, combined ² – g/km	276
Emissions standard	EU5
Fuel tank capacity/of which reserve – l	93/14
Boot capacity – l	
max. behind 1st row of seats	2,010
max. behind 2nd row of seats	690
Turning circle – m	11.80
Kerb weight ³ /Perm. Gross Vehicle Weight – kg	2,345/3,050
Towing capacity, braked/unbraked – kg	3,050/750

³Figures according to Directive 92/21/EC, version 95/48/EC (kerb weight with fuel tank 90% full, driver, 68 kg, and luggage, 7 kg) for standard-specification vehicles. Optional extras and accessories will generally increase this figure and reduce the payload capacity accordingly

⁴In conjunction with AMG Performance Package ⁵Electronically limited ⁶In conjunction with AMG Driver's Package For further technical data, please visit www.mercedes-benz.co.uk



Paint finishes

Non-metallic paint



149

Metallic paints

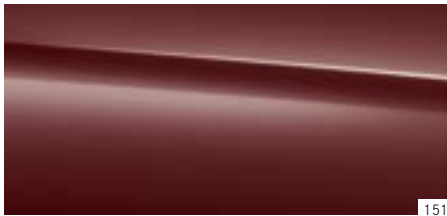

151

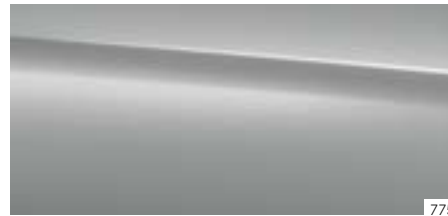

775



799¹

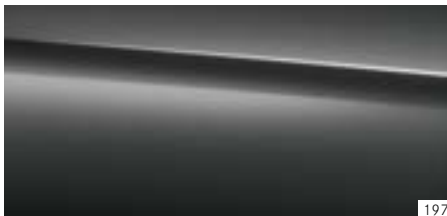

197

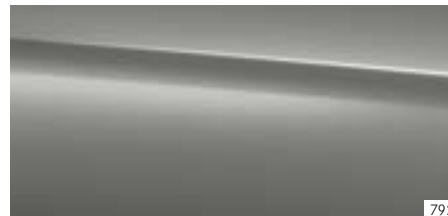

792



890



755



796



988

Non-metallic paint

149 Polar white

Metallic paints

151 Cinnabar Red

197 Obsidian Black

755 Tenorite Grey

775 Iridium Silver

792 Palladium Silver

796 Citrine Brown

799 Diamond White¹

890 Cavansite Blue

988 Diamond Silver

¹Additional-cost option



Take-back of end-of-life vehicles. Coming full circle. At the end of its long life, you can return your M-Class to us for environment-friendly disposal in accordance with the EC End-of-Life Vehicle Directive.¹ But that day lies a long way off.

¹Applies in accordance with national regulations to vehicles up to 3.5 t permissible gross weight. The M-Class has met the statutory regulations governing the suitability of the vehicle's design for reuse and recycling for a number of years now. A network of vehicle take-back depots and dismantlers has been established which will process your vehicle in an environment-friendly manner. The ways in which both vehicles and parts can be recovered are subject to ongoing development and improvement. Consequently, the M-Class will be able to comply with any future increases in the recycling quota within the stipulated time limits. Further information is available at www.mercedes-benz.co.uk or by calling 0808 156 6606.

Please note: this online version of the printed brochure may contain abridged copy or other content changes. The manufacturer reserves the right to make changes to the design, form, colour and specification during the delivery period, provided these changes, while taking into account the interests of the vendor, can be deemed reasonable with respect to the purchaser. Where the vendor or the manufacturer uses symbols or numbers to describe an order or the subject of an order, no rights may be derived solely from these. The illustrations may show accessories and items of optional equipment which are not part of standard specification. Colours may differ slightly from those shown in the brochure, owing to the limitations of the printing process. This brochure has been compiled by Daimler AG of Germany and is distributed internationally. It provides a general indication of the range of models, features, optional extras and/or colours available in various countries. Some of the models, features, optional extras and/or colours shown may not be available in your country or may only be available in a different specification. Additionally some models, features, optional extras and/or colours may only be available in combination with others. For current and more specific information in relation to the range of models, features, optional extras and/or colours available in your country, and their pricing, you should contact your nearest authorised Mercedes-Benz Retailer. E&OE. www.mercedes-benz.co.uk

Daimler AG, Mercedesstr. 137, 70327 Stuttgart BC/MC 6701 · 1210 · 88-02/0613 Printed in Germany

