

# The new Unimog

The high-performance implement carrier



Mercedes-Benz  
Trucks you can trust

# Setting standards. Extending limits. Mercedes-Benz implement carriers

Progress and safety, perfection and responsibility, performance and innovation – these are only a few of the values which Unimog customers quite rightly connect with Mercedes-Benz. We have reinterpreted these values for the new Unimog and the result is an implement carrier which achieves new standards in productivity, efficiency and environmental acceptability. It unites state-of-the-art truck technology and outstanding advanced system and implement-carrying solutions to provide a successful overall concept. Therefore it is truer than ever to say: The new Unimog is an investment with a future.

## Contents

The Unimog concept	4
Efficient and innovative	6
Compact and agile	8
Ergonomic work place	10
Safety	14
BlueEFFICIENCY Power	16
New traction drive	20
Advanced system solutions	22
Mercedes-Benz Quality	28
Financial Services	30
Mercedes-Benz Service	32
Models and versions	34

---

Further information is available online:  
[www.newunimog.com](http://www.newunimog.com)

---

# A new interpretation of a unique idea: the Unimog

The Mercedes-Benz Unimog was designed especially for carrying implements. This has practical advantages right up to the present day.

Its safety and reliability on the job together with its advanced system and implement-carrying solutions have made the Unimog a professional implement carrier for over 60 years. The originally-named 'Universal-Motor-Gerät' (Universal Motorised Working Machine) is a vehicle which has been designed specifically for this purpose. It was only in connection with the many qualified body manufacturers and the wide know-how of the Unimog Dealers that a system could be created with a flexibility and productivity which is still unequalled today. But in spite of all its capabilities, its dimensions are still extremely compact – and it is because of this that the implement carrier is able to make full use of its efficiency almost everywhere.

## Chassis design: Nothing can wind a Unimog up!

It is able to cope with the greatest of challenges during a hard working day with its mature chassis design based on a sturdy ladder-type frame. Its permanent all-wheel drive, great ground clearance due to portal axles, a very comfortable drive, wide axle articulation and differential-locks in both axles are characteristic for the Unimog. The implement carrier is also in its element way off beaten tracks due to its single tyres, central tyre inflation system and its extremely well-balanced weight distribution – and it also manages to keep up a good speed of up to 90 km/h (56 mp/h) when travelling on-road.

Chassis design



Implement-carrying design



Attachment and body-mounting areas

## Implement-carrying design: the perfect all-rounder for year-round use.

The Unimog implement carrier more than deserves its good reputation as a workhorse. It provides top performance in very varying work situations 365 days a year with its outstanding four attachment and body-mounting areas. The hydraulic, mechanical and electric energy supply for the implements makes it versatile to work with, providing just the right kind of power system for each of the over 1000 possible jobs it may be required to do.

## Advanced system solutions: a vehicle which can be used worldwide with over 1000 implements and for a wide range of jobs.

The Mercedes-Benz Unimog is able to take on an unprecedented range of jobs. In addition to its well-known work for very varying branches, the professional implement carrier provides a unique and variable platform for doing a countless number of jobs at any time of year. For decades now, Mercedes-Benz has been working closely with international implement and body-manufacturers, uniting the experience and competence of specialists with the know-how from their competent Unimog Dealers – thus providing the best foundation for perfect customised solutions.



# Setting new standards for efficiency

The innovations of the new Unimog implement carrier at a glance



- + Economic to run**
- + Year-round use as an all-round vehicle with over a 1000 possibilities
- + Low consumption of fuel, AdBlue and engine oil
- + State-of-the-art and efficient Mercedes-Benz drive technology, tried and tested in large-scale production
- + Low maintenance costs due to longer intervals between inspections
- + New, easy-to-maintain cooling system
- + Powerful premium engine brake
- + Very good corrosion protection

- + Powerful performance**
- + Powerful engines up to 220 kW (299 hp) and up to 1200 Nm torque
- + Uprated transmission with practice-oriented gear spacing
- + Greater productivity with stronger power hydraulics VarioPower®
- + Higher payload due to higher load ratings
- + Absolutely proportional hydraulic system for sensitive implement control
- + Driving speeds up to 90 km/h (56 mp/h)

- + Environmentally acceptable**
- + New, clean BlueEFFICIENCY Power generation of engines in accordance with Euro VI emission standards
- + Drastic reduction of emissions and particulates (PM) by up to 90% in comparison with previous models with Euro V engines

- + Made for the job**
- + Spacious panoramic cab
- + Attractive exterior with newly-designed front
- + New front-camera monitoring system (optional extra) improves visibility at close range
- + Active and passive safety package
- + New roof-mounted wiper system

- + Compact and agile**
- + Even more compact dimensions for manoeuvring at close quarters
- + Shortened wheelbase from 2800 mm
- + Smaller turning circle provides top manoeuvrability and agility
- + Auxiliary rear axle steering (optional)

- + Easy-to-operate**
- + New and intuitive control system
- + New multifunction steering wheel
- + Modern and ergonomic interior
- + Adjustable steering column
- + Improved heating and cooling system
- + Optional central tyre inflation system with practice-oriented pre-settings for different types of terrain

- + Innovative**
- + New advanced synergetic traction drive for continuously variable operation up to 50 km/h (31 mp/h)
- + Smooth changeover from work to drive modes

# Can make the most of its strength almost anywhere: The compact implement carrier

The new Unimog implement carrier is even more compact and agile

## Compactness and agility express the advantages of the central idea behind the Unimog implement carrier.

These advantages have been improved once more for the new generation as the designers at Mercedes-Benz Special Trucks have shortened the compact wheelbase once more and made the turning circle even smaller. Also the typical short front-end, its low overall height and narrow width remain features of the new generation.

After all, the Unimog is not only expected to use its strength on the road but also in every small corner. This has made the new generation of the implement carrier even more versatile as getting through narrow alleys or manoeuvring in confined spaces is now even simpler – and that means faster. The new Unimog is still one of the most compact commercial vehicles in its weight and performance class.

Even smaller turning circles: The Unimog implement carrier is still agile in confined situations. In comparison: A vehicle like the Mercedes-Benz B-Class has a turning circle of about 11 m, and a truck like the Mercedes-Benz Axor 1823 (4x4) has about 15.2 m

## New Manoeuvring in a tight corner: Turning circle from 12.6 m

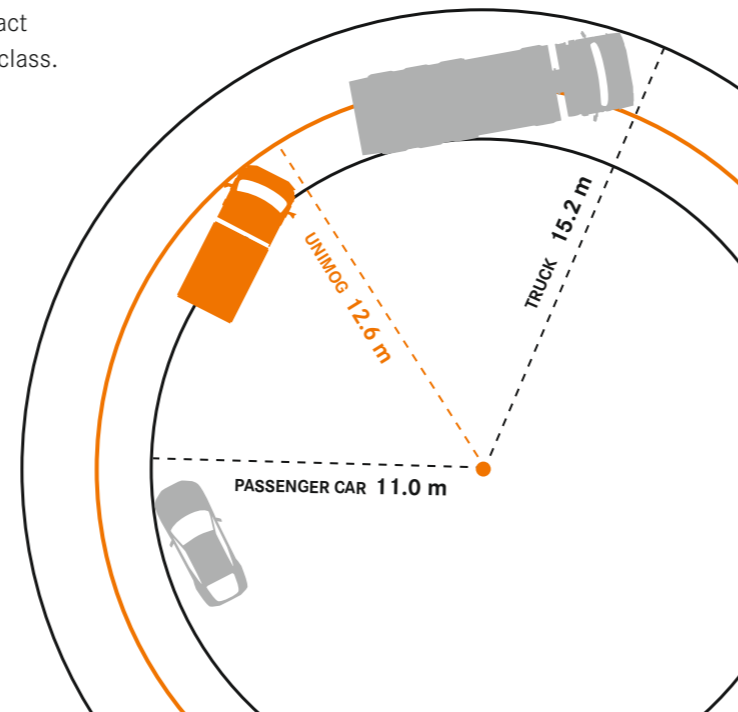

Short wheelbase, compact dimensions: The Unimog implement carrier is extremely agile

The new compact models: Unimog U 216 and U 218

And it gets even better: The new Unimog models U 216 and U 218 have an even shorter wheelbase of 2800 mm and compact dimensions. This means that they can work in situations where every millimetre counts: Finding their way round narrow streets in old city centres or driving through low entries – due to their smaller wheels, the overall height is also lower. Of course, both of the new and extremely compact Unimog models are also genuine

implement carriers so that operators do not have to lower their sights from a practical point of view. Fitted with 115 kW or 130 kW engines, both models are powerful enough to cope with almost any challenge. The payload of U 216 and U 218 also provides three different load ratings from 7.5 to 10 t which means that they are able to deal easily with the multitude of jobs they are expected to do.

## New The most compact of the new implement carriers



### U 216 and U 218 highlights:

- + The very short wheelbase allows it to manoeuvre in practically every situation
- + Outstanding implement-carrying qualities fitted in the smallest space
- + Maximum weight of up to 10 t
- + Easy-to-maintain and wear-resistant pneumatic brake system

Unimog U 216 and U 218: Technology upgrade for the smallest Unimog. The shorter wheelbases are responsible for the great agility of the vehicles

## A sought-after place to work

New interior with ergonomic design and very easy-to-operate controls

Get in, feel at home, start work: The experience and requests from many users have gone into the advanced design of the new cab. These include an even more comfortable sitting position, improved implement control with the new multifunction joystick and a fast overview of all the vehicle settings in the new instrument cluster. These improvements play an important role in improving safety and ease of operation and make sure that work and comfort go hand in hand in the new Unimog.



Spacious surroundings:  
The new implement carrier has one of the most modern work places – and one of the most sought after.



The standard height and tilt-adjustable steering column provides the correct seating position for the driver



## Provide the best working conditions: the new controls

Anyone not just wanting to move a vehicle from A to B, but intending to work hard in it day after day has different requirements regarding controls and comfort. The newly-designed work place and cockpit are perfectly adjusted to the user and provide the best possible working conditions. They play their part in ensuring that every job can be completed with full concentration while feeling relaxed. For instance, by making sure all the controls are located within easy reach.

The interior is very carefully arranged. Signs of fatigue are reduced with the optional air-sprung driving seat combined with the low-vibration cab. Anyone spending a lot of time in the new cab really learns to appreciate the powerful air-conditioning and heating system which is able to create comfortable working temperatures in any kind of weather. In winter, the seat heating can also be switched on if needed. And so that work can start punctually at any time, there is a programmable auxiliary heater. Heated windows and mirrors also make sure that visibility is good right from the start. In addition there are a great many practical details waiting to be discovered such as a CD radio with Bluetooth hands-free system and additional stowage space.

New	The new controls: Innovative details and functions:
01	The new multifunction steering wheel fits your grip perfectly and allows easy access to the display of the instrument cluster and the hands-free system
02	On its large and light display, the new instrument cluster gives all the important information such as oil level, air pressure or hydraulic system settings
03	Driving functions such as gear changing, engine brake (right) and the hydrostatic traction drive (left) are integrated in the new steering column control arms
04	The new, removable multifunction joystick for controlling work operations and speeds is located in the central console. The controls for the synchronised reversing group Electronic Quick Reverse (EQR) are also to be found here
05	Drivers can always be working in the best possible seating position thanks to the optional innovative transferable steering VarioPilot®

# Safety concept

Extremely safe on the job

As a state-of-the-art commercial vehicle, the Unimog does not make any compromises where safety is concerned. With its active and passive systems both operators and other road users are well-protected. The most important features are the outstanding visibility to the front with its short front end dimensions and panoramic cab, directional stability, Anti-Lock Braking System (ABS), precise handling, extremely good axle load distribution and its low-vibration work place with three-point safety belt and headrest. The new generation of the implement carrier now has an advanced version of this safety concept: The exterior design with a new wiper system fitted to the roof improves the cleaning of the windscreen and the new headlamps with daytime running lights improve visibility and vehicle perception. The optional front camera monitoring system supports the view at close range in front of the vehicle and is a great help when fitting implements attached to the front.

## Safety at work. The Unimog

Further information and the safety guide:  
[www.mercedes-benz.com/unimog-safety](http://www.mercedes-benz.com/unimog-safety)



The new exterior design with its short front bonnet and very wide field of vision over both driving and working areas make the Unimog a particularly safe commercial vehicle.

New

The new front camera monitoring system

The new optional front camera monitoring system has two great advantages: it gives a greatly improved overview of the area in front of the vehicle and it assists when attaching implements. The camera is integrated in the newly designed front of the vehicle and the image is relayed to a monitor in the interior of the cab. This allows the driver to see exactly what is happening directly in front of the vehicle and provides a perfect view of the front mounting plate when changing implements.



Panoramic cab

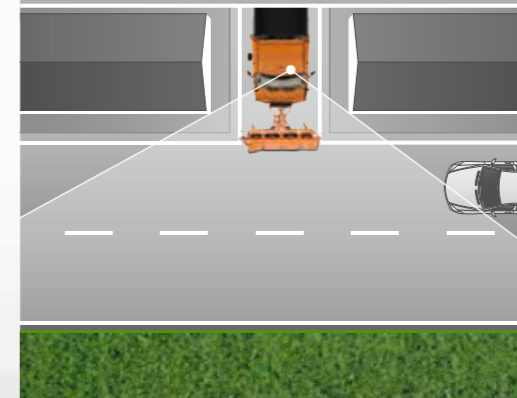

Good handling

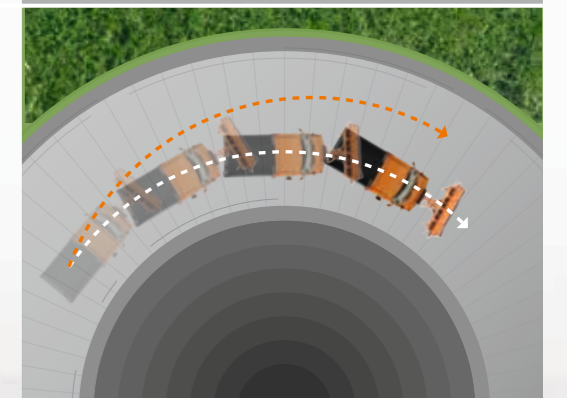

Especially when using front-attached implements, the front-end dimensions and position of the driver play an important role. The Unimog clearly undercuts the standard legal distance of 3.5 m even with implements attached

The Unimog benefits from its well-balanced axle-load distribution especially when driving round bends on slippery roads



# BlueEFFICIENCY Power

Facing the future efficiently

When the new Unimog takes to the road it will be accompanied by a great number of innovative solutions which will clearly increase its efficiency and reduce its emissions. That is what BlueEFFICIENCY Power stands for. Under this brand name, Mercedes-Benz has grouped all of its technologies which make a contribution to sustainability, environmental acceptability, reducing CO<sub>2</sub> and making fuels more efficient. Complying with the new Euro VI standards is only a small part of this. The basis for achieving the ambitious aims connected with BlueEFFICIENCY Power is an entirely new drivetrain with state-of-the-art diesel engines, an updated transmission and reinforced axles which make it possible to increase the load ratings of all models. At the same time, by integrating the high-tech components, the Unimog becomes even more economical.

Further information about BlueEFFICIENCY Power and the new environmentally-friendly drive system is available online:  
[www.newunimog.com](http://www.newunimog.com)



+ Engine
+ Powerful state-of-the-art 4 and 6-cylinder engines from 115 to 220 kW (156 to 299 hp)
+ Up to 1200 nm torque
+ Comply with Euro VI emission standards
+ Greater cubic capacity, quieter running, increased efficiency

+ Transmission
+ Simpler handling
+ Longer life span
+ New synergetic traction drive combines manual transmission and hydrostatic transmission as required for the job

+ Axles and wheels
+ Reinforced axles for higher load ratings
+ Pneumatic disc brakes
+ Aluminium wheels to increase payload
+ Central tyre inflation system with new settings according to job requirements

# The driving force behind economic efficiency: Perfectly coordinated drive technology with Euro VI

**Mercedes-Benz BlueEFFICIENCY Power technology does more than just fulfil the standards required by Euro VI.** For instance, with the new Mercedes-Benz engine generation, tried and tested in large-scale production. It sets new standards for its class and takes no half-measures where conserving the environment, economic efficiency and top performance are concerned. Among other things, the extremely effective new cooling system and exhaust gas aftertreatment unit are responsible for the outstanding results.

**The modern 4 and 6-cylinder engines from 115 to 220 kW are especially easy to maintain, economical, run smoothly and have powerful acceleration.** They also have more torque as well as good results for exhaust gas, fuel consumption and power/weight ratio. Because of this, the performance level of the strongest 4-cylinder engine corresponds to that of one of the 6-cylinder engines in use up to now. 4-valve technology and Common Rail high-pressure injection with 2400 bar make them even more effective. The engines are also used for braking: the powerful premium engine brake reduces mechanical wear on the brakes and makes a great contribution to economic efficiency.

**Lower emissions mean more sense of responsibility.** For exhaust gas aftertreatment, the new generation of engines relies on BlueEFFICIENCY Power technology which has already proved its worth by being tried and tested in heavy-duty large-scale production engines. In the exhaust gas aftertreatment unit, the well-tested Selective Catalytic Reduction (SCR) catalytic converter reduces the nitrogen oxides to a minimum. The amount of the additive AdBlue required for this sinks significantly. And the diesel particulate filter prevents almost any soot particles from escaping.

**Transmission with very effective advanced design.** The fully synchronised electro-pneumatic transmission with its eight forward and six reverse gears provides the tractive power. The transmission is very smooth running, effective and has a long life span. And the synchronised reversing group Electronic Quick Reverse makes it much easier to change direction, as for instance when clearing snow or manoeuvring in confined spaces – available as an optional extra with a forwards-back reversing switch integrated in the multifunction joystick.

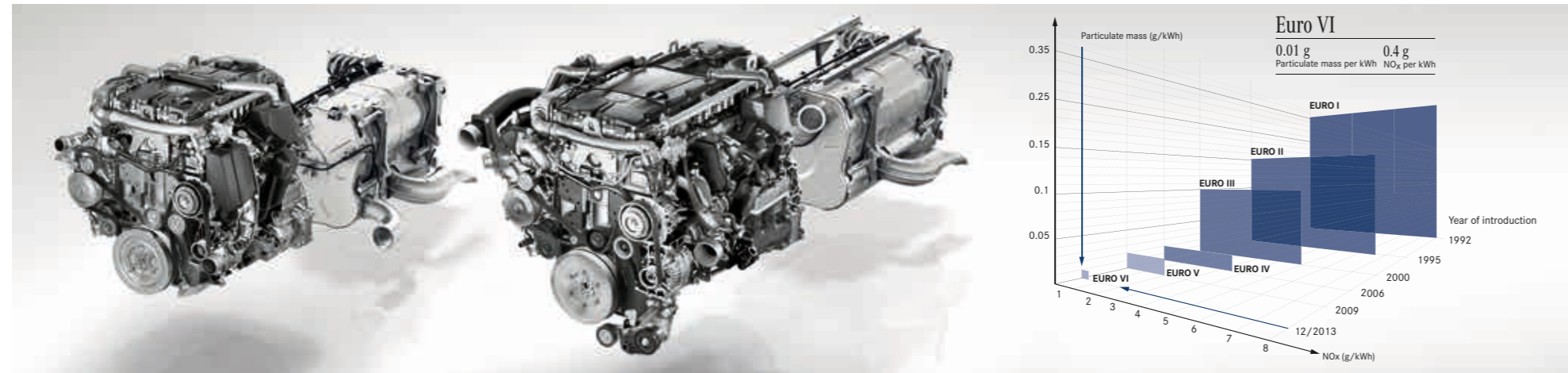

**Better performance, lower emissions:** The new BlueEFFICIENCY Power engines are available for the first time for the Unimog as 4 and 6-cylinder engines with a top performance of 220 kW. Together with the cooling system and the exhaust gas aftertreatment unit, these modern engines comply with the strict new standards laid down for emission standards Euro VI. These require diesel particulate and nitrogen oxides to be reduced by 90% compared with Euro V

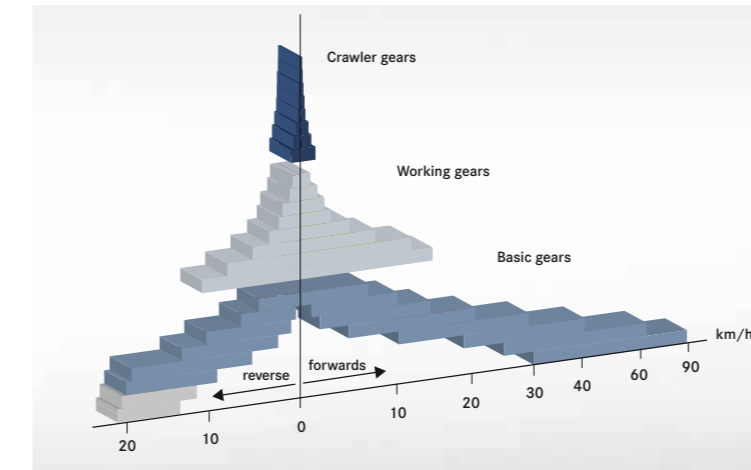

The perfect gear for every job: With its total of 24 forwards and 22 or 24 reverse gears, the Unimog always has the perfect working and driving speed



The transmission can be operated easily with the steering column control arm on the right. The premium engine brake is also operated here



# Innovative traction drive

Adjusted precisely to the job on hand:  
the new synergetic traction drive

The new system combines the advantages of fuel-saving manual transmission and infinitely variable hydrostatic traction drive. The advantages become quickly apparent when used on the job: The working speed can be set at any position independently of the engine speed and be maintained precisely using the cruise control function. And when going to new job locations or manoeuvring, the driver can simply change between the infinitely variable mode and manual transmission while driving. This makes vehicle handling easier and increases productivity.



**Top technology: The innovative new synergetic traction drive.** The new traction drive is designed to give precise performance. The speed can be adjusted infinitely variably in a much wider speed range from 0 to 50 km/h (31 mp/h). At the same time it is extremely efficient and very easy to operate. Much higher traction is achieved with the optimised high pressure regulation and this considerably improves the performance of the Unimog implement carrier. The system allows the driver to change between mechanical and synergetic working modes when driving which means that he can work efficiently and effectively with the most suitable speed.

**No interruption when changing between working and driving.** The new function known as Drive-Work-Mode is an invaluable assistant for everyday work. If, for instance, one mowing section has been finished, the driver can simply change smoothly into manual transmission. And this is how it is done: When the hydrostatic drive reaches its top speed of 50 km/h (31 mp/h), the engine switches over to manual transmission either by pressing the clutch, or – as an optional extra – automatically. This makes it easier and safer to leave lanes of moving traffic – and from now on the decision as to which drive mode is the most suitable for the current situation is taken spontaneously – and without the need to brake.

New	Synergetic traction drive
<p><b>The synergetic traction drive can be varied in four different ways:</b></p> <ul style="list-style-type: none"> <li>+ with the accelerator and brake</li> <li>+ using the work cruise control</li> <li>+ with the left steering column control arm</li> <li>+ with the new multifunction joystick</li> </ul>	
<p><b>Further advantages</b></p> <ul style="list-style-type: none"> <li>+ Gear selection is possible while driving</li> <li>+ Smooth change between manual transmission and hydrostatic traction drive</li> <li>+ Simple to operate and activate</li> <li>+ Work mode for working with constant engine speeds</li> <li>+ Drive mode for infinitely variable speeds from 0 to 50 km/h (31 mp/h)</li> <li>+ Choice between job-related driving conditions: 'efficient', 'comfortable' and 'powerful'</li> </ul>	



**New steering column control arm:** Operators can change the driving direction and gear and set the cruise control with their left hand – and have the right hand free to use the multifunction joystick for, e.g. positioning implements

# Advanced system solutions

A convincing all-rounder: The Unimog implement carrier makes its mark by being extremely versatile on the job

For generations the Unimog has been showing others just how to achieve year-round versatility on the job. The reason: The implement carrier is a unique vehicle concept which has been specially designed for use with implements. Individual system solutions to increase productivity and ensure the full use of the vehicle pool are created together with our many qualified implement partners. The implement carrier is also top of the line when it comes to implement drive and control. And the new removable multifunction joystick makes operating implements even simpler – and that means safer.

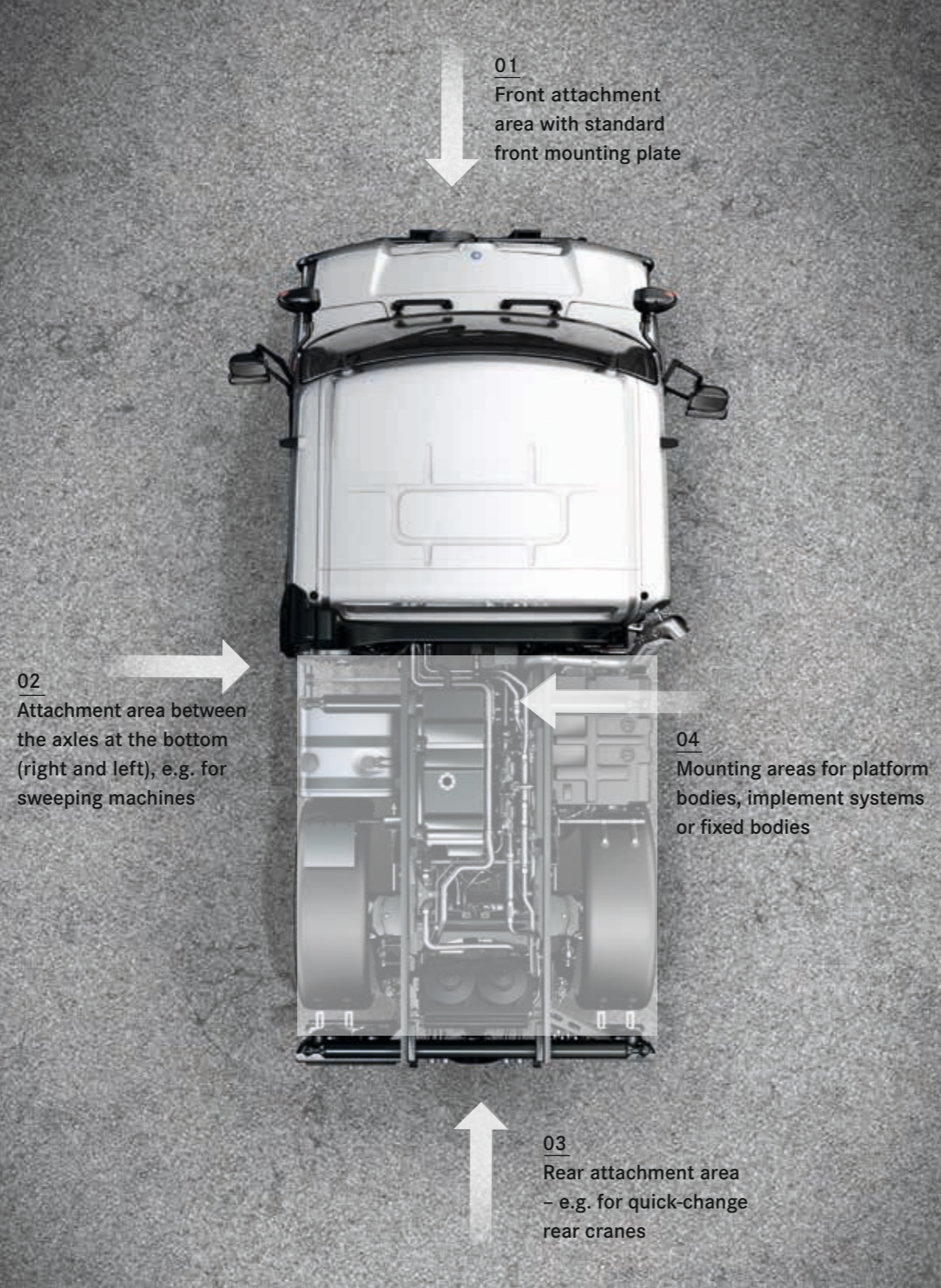

01  
Front attachment area with standard front mounting plate

02  
Attachment area between the axles at the bottom (right and left), e.g. for sweeping machines

04  
Mounting areas for platform bodies, implement systems or fixed bodies

03  
Rear attachment area – e.g. for quick-change rear cranes



Simplified and intuitive implement operation with the new removable multifunction joystick



Four attachment and mounting areas: the Unimog implement carrier is one of the most productive working machines in existence. A very wide range of implements can be combined thanks to its standardised interfaces and over 1000 different uses are possible. The system includes the front mounting plate, attachment points on the frame, mounting brackets on the sides and at the rear as well as ball-point positions on the platform sub-frame

New	Powerful and versatile operation:
<ul style="list-style-type: none"> <li>+ Over 1000 uses are possible with the Unimog combined with various implements</li> <li>+ Most existing implements are still compatible</li> <li>+ The four attachment and mounting areas and the standardised interfaces are still part of the system</li> <li>+ The mounting brackets at the rear can now bear greater loads – up to 2.5 t</li> </ul>	

**More work each time: The combination of attachment and mounting areas as well as hydraulic and mechanical implement drives and controls turns the vehicle into a genuine workhorse.** The sturdy ladder-type frame with integrated mounting positions provides the basis for the wide range of work the Unimog can do

**Working together to provide top quality:** The wide range of over 1000 products from highly specialised implement and body-building manufacturers makes the Unimog the perfect partner as customers are able to use the entire vehicle in a great number of different ways. This means that we and our partner manufacturers can ensure lasting high quality for the entire vehicle

**The Unimog provides a total of three attachment areas and one mounting area:**

- + Attachment areas are to be found at the front, between the axles and at the rear. They can also be used simultaneously which makes work much more efficient. The standard front mounting plate makes it easy to exchange the most important implements
- + The mounting area is on the platform body. Bodies can also be mounted directly on the ladder-type frame or on the ball point positions on the platform frame. A greater payload is possible if the platform is removed



The new Unimog is even capable of performing very complex movements fast and sensitively. The snowplough relief improves traction and reduces wear



The separate tipping hydraulics system allows platform bodies or trailers to be tipped independently from the working hydraulics

## The new working hydraulics are entirely proportional

**30% per cent higher hydraulic performance and more sensitive than ever: The new working hydraulics control implements more precisely and entirely without any jolting movements.** In this way, daily efficiency is improved with the new and advanced design of the entirely proportional hydraulics system. With the working hydraulics two positioning movements can be done at the same time simply by using the multifunction joystick. Other functions can be entered via the steering wheel buttons. Up to 30 l of hydraulic oil can be removed which means that even larger tipping cylinders on trailers can be refilled.

**The four-cell working hydraulics of the implement carrier has two circuits.** Circuit I controls up to eight implement positioning movements with 200 bar system pressure (32 l/min) via four doubly effective valves or it runs hydraulic motors in the lower performance range. A good 35 kW with up to 240 bar pressure can be used with the combined configuration of Circuit I and II (32 plus 55 l/min). This makes it possible to run a hydraulic motor and carry out implement positioning movements independently from one another.

Tipping hydraulics	20 l /min, 185 bar
Working hydraulics Single circuit	55 l /min, 200 bar Circuit I
Working hydraulics Dual circuit	32 l /min, 200 bar Circuit I
	55 l /min, 240 bar Circuit II
	87 l /min, 240 bar Circuit I + II
Power hydraulics Circuit III	125 l /min, 280 bar
Power hydraulics Circuit IV	125 l /min, 280 bar

## Powerful and efficient: the new power hydraulics VarioPower®

**Two circuits, both with 125 l hydraulic oil flow per minute and 280 bar pressure. It does not matter how hard the work, with its new power hydraulics the Unimog is able to cope.** Regardless of whether several work operations have to be done at the same time or if a job needs more power – VarioPower® power hydraulics are capable of even more as both of the open circuits III and IV now have the same power output of 125 l hydraulic oil flow, a system pressure of 280 bar and a top performance of 59 kW

at their disposal. This means that the power hydraulics now replaces pumps attached to the Power Take-Off (PTO) or additionally mounted diesel motors. The VarioPower® controls are new and simple to operate using the steering wheel buttons on the multifunction steering wheel. The adjustments are shown on the display of the new instrument cluster. The power hydraulics are installed on the platform subframe and can be removed from the subframe if, for instance, the payload needs to be increased for winter services.



With its hydraulic systems, the Unimog is able to do up to three jobs at the same time with its triple mowing combination

### New Fast and easy cleaning for the cooling system

The new arrangement of the cooling system and its components makes sure that all of the units are kept cool even when surrounding temperatures are high, driving speeds low and jobs exceedingly dirty. The cleaning of the cooling system has also been improved: simply open the screen and blow the filter clean with the compressed air pistol. The cooling system can also be cleaned automatically with the reversible fan – available as an optional extra – which reverses the airflow with a multi-timer interval control.



Hydraulic connections for up to four circuits are safely installed at the front and rear of the vehicle

## Mechanical implement drive: the time-tried high achiever

**Full speed ahead: for many jobs the mechanical implement drives have just the right output.**

The Unimog has quite a number of them available as optional extras including a front PTO with a continuous output of 160 kW. An engine-run PTO and a transmission-run PTO are also available as optional extras. The mechanical drives come into their own for jobs with high power requirements.



Working with the front PTO: great power reserves even when doing power-intensive jobs such as with a snow cutter

**Powerful front PTO with up to 160 kW: the direct source of power.** Front-attached implements requiring a great deal of power are run off the front PTO which takes its power directly from the drivetrain of the engine. It is oil-cooled as a standard feature and provides a high torque transfer and a very high degree of efficiency with its 1 3/4" splined shaft – especially in continuous operation. By using the speed indicator in the instrument cluster and setting the rpm from 420 to 1000 rpm, the PTO can be used to drive implements at 540 rpm or 1000 rpm standard engine speed.

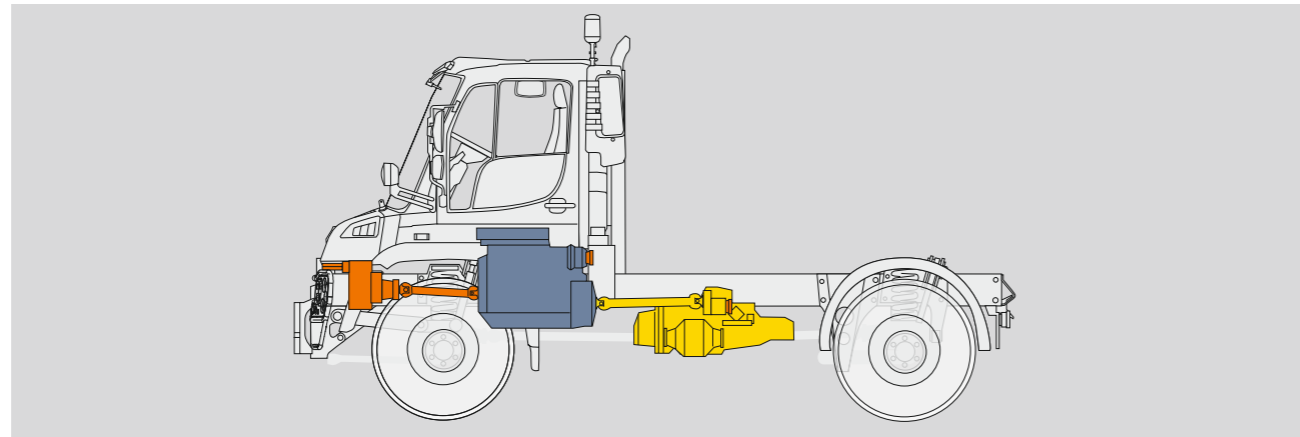

The new Unimog implement carrier has kept the positions of the front PTO (orange), engine-run PTO (blue) and transmission-run PTO (yellow)

**PTOs (Power take-off) from engine and transmission: Two further performance options.** The engine-run PTO run off the Unimog implement carrier drives the power hydraulics, but it can also be used to run powerful implements in combination with a hydrostatic drive. The transmission-run PTO with its standardised flange on the manual transmission also allows commercially available hydraulic pumps to operate cranes and elevating work platforms. The output speed and direction of rotation are identical to the output speed and direction of rotation of the engine.



## Electric interfaces: Plug in and work

**Four standardised sockets in the cab and outside allow units run on electricity or implement controls to be connected without needing any additional cable installations.** The on-board power supply gets its energy from a 24 V and 100 A three-phase alternator and the programmable on-board electronics system makes it easy to provide settings such as engine speed limitations to protect mechanically driven implements, a drive-off lock when hydraulic support legs are still in place or speed limits.



# Quality from Mercedes-Benz

The new Unimog integrates leading commercial vehicle technology tried and tested in large-scale production

**Built in Wörth, the largest truck assembly plant in the world: the new Unimog comes up to the high quality standards of the commercial vehicles branch worldwide.** As a global leader of medium-heavy and heavy trucks, Mercedes-Benz sets itself ambitious targets: Standards define quality and reliability. And the workforce of over 11,000 located at the modern and environmentally-friendly Wörth plant come up to these expectations. Since 1963, over three million commercial vehicles have been manufactured here. In the same way as the so-called A-series Actros, Arocs, Antos and Atego,

Mercedes-Benz Special Trucks also designs and manufactures all its vehicles with many identical components. Its fleet comprises the new Unimog implement carrier, the outstandingly mobile off-road Unimog, the Econic and the Zetros. The model series are all given the same extremely strict testing and trial cycles as the large-scale production series. The passion for commercial vehicles is expressed best by the motto of the workforce at Wörth, "We aspire to get somewhat better every single day to keep our brand promise to our customers: Trucks you can trust."



**Mercedes-Benz plant at Wörth:** The Mercedes-Benz Unimog is designed and manufactured at the world's largest truck plant. The engines come from the Mercedes-Benz Engine Plant in Mannheim



**High quality standards:** Mercedes-Benz sets itself very high quality standards for every Unimog produced – from its development, through its testing and in production



# Financial Services

Flexibility which gives plenty of elbow-room

## Our customised financial services make your accounting more flexible

Together with Mercedes-Benz Finance and our Unimog Dealers, we are able to make customised service offers such as leasing and financing products, along with full repair and maintenance. Further information is available from your Authorised Mercedes-Benz Dealer.

### Creating better value. Mercedes-Benz Financial Services

- + Other finance and leasing products we offer are: Hire Purchase, Hire Purchase with Balloon, Operating Lease, Finance Lease
- + The company with its headquarters in Stuttgart is active in almost 40 countries and of all the automotive financial service providers it has the most international experience
- + Daimler Financial Services employs about 7000 staff worldwide

## Financial Services

We provide finance you can trust for trucks you can trust. Mercedes-Benz Finance was established in the UK more than 21 years ago and has over 131,000 finance contracts. We offer the only finance designed specifically for Mercedes-Benz vehicles and tailored to all fleet sizes and business sectors in the UK.

Approved credit applications are normally processed in as few as 19 minutes and 97% of our customers were satisfied, very satisfied or completely satisfied. Our experienced Business Managers will work with you to understand your business needs and will provide you with a business solution when funding your vehicles.

Our most popular finance product is Mercedes-Benz Contract Hire. With one monthly payment, Mercedes-Benz Contract Hire can take care of all your fleet needs. We also offer two levels of service contracts with factory trained technicians who only use Mercedes-Benz GenuineParts, keeping you 100% Mercedes-Benz.

**Your Unimog Dealer will be happy to make you a customised offer. Please give him a call!**

## Contract Hire

Contract Hire can be a great way to reduce the hassle of running a commercial fleet. It requires no capital investment and the vehicle is not shown on your balance sheet.

### How does Mercedes-Benz Contract Hire work?

Instead of owning the vehicle or vehicles, you hire them for a fixed period – typically three to five years – for a fixed monthly fee. Because this fee is based on the difference between the initial value of the vehicles and their projected value at the end of the contract.

At Mercedes-Benz we offer a range of ways for you to fund the purchase of your new vehicle. One of our most flexible finance products is Mercedes-Benz Agility.

## How does Mercedes-Benz Agility work?

At the start of the agreement your Business Manager will advise you of the Guaranteed Future Value for your truck based on the mileage that you expect to cover during the course of your agreement. This Guaranteed Future Value is equal to the final Optional Purchase Payment – but you do not have to decide whether to make this payment and keep the truck until the end of the agreement. In the meantime, you simply choose how long you want to keep the truck, how much you would like to pay as an initial deposit and the monthly payments that suit you best. When the agreement comes to an end you can either purchase, return or part-exchange the vehicle.

### The Benefits of Agility

- Lower your monthly repayments – as we can guarantee the future value of your truck.
- Defer the decision to own the truck outright until the end of the agreement.
- Decide upon the level of deposit and monthly repayments that suit you best.
- Enjoy a risk-free finance experience as the future value of the truck is underwritten by Mercedes-Benz.
- Avoid the risk of depreciation and benefit through more affordable payments.
- Monthly repayments are kept low by agreeing on a lump sum at the end of the finance term called the ‘Guaranteed Future Value’.





# Mercedes-Benz Service

Our entire commitment is to make sure you are mobile

**Wherever you use your Unimog – Mercedes-Benz is already on the spot.** We are available at over 650 Unimog service stations in over 130 countries to take care of your Unimog – and also immediately if need be. And with the same care, the same experience and the same technical capabilities we used to build it. That is ensured by our area-wide service with competent Unimog Dealers. Because our customers recognise one thing in everything we do: genuine enthusiasm.

**We respect experience. Also that of others.** Active care is the most important thing in service. And this includes exchanging experiences. With our customers – but also with our colleagues. And this is how questions can be solved efficiently and economically. In this way our service partners are able to provide high standards day in and day out as far as quality, costs and ecological awareness are concerned. And by making clear statements, thorough failure analysis and cost-oriented solutions. Should parts need to be exchanged, then of course only Mercedes-Benz GenuineParts are used which come up to our strict standards of quality and availability.

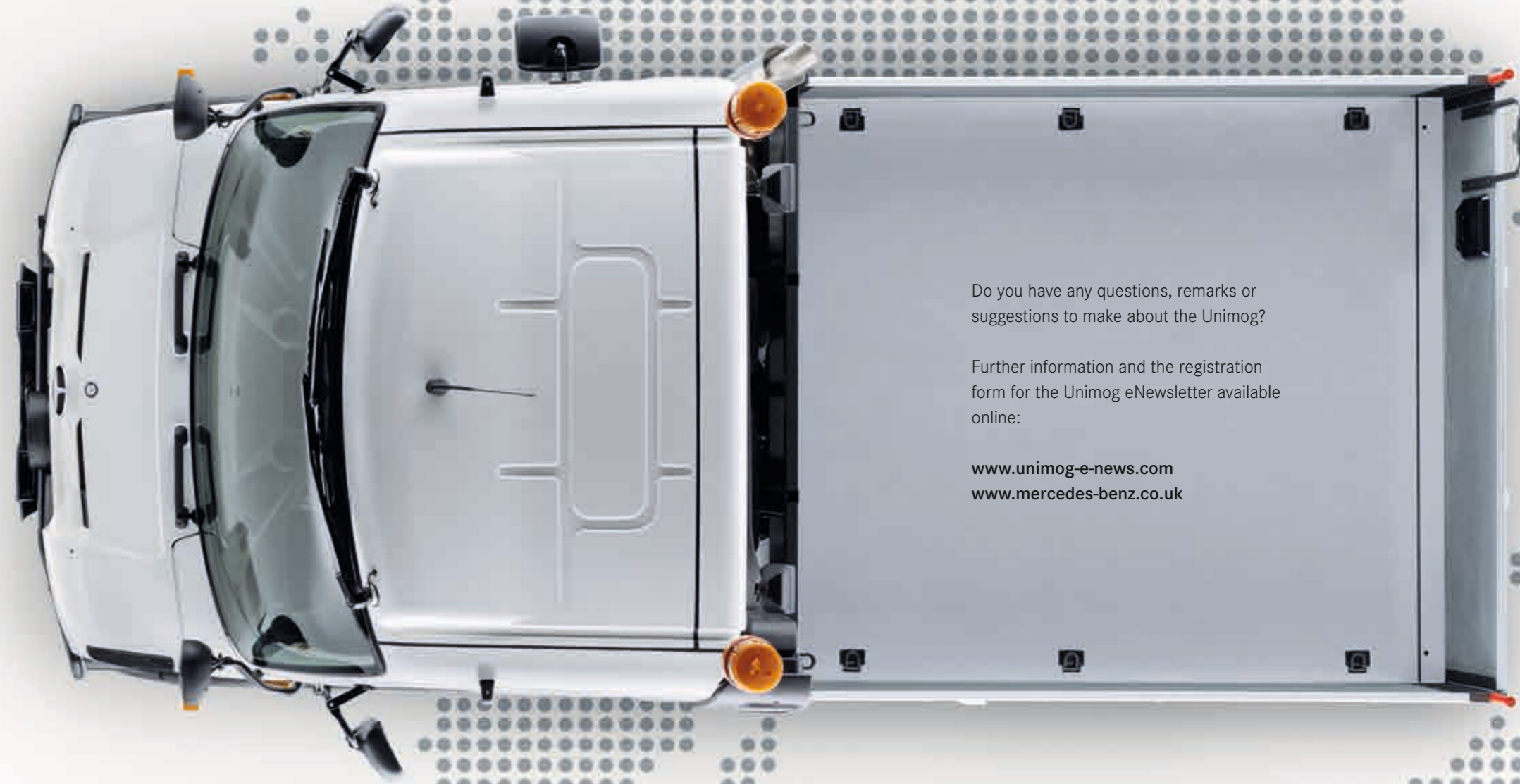

Do you have any questions, remarks or suggestions to make about the Unimog?

Further information and the registration form for the Unimog eNewsletter available online:

[www.unimog-e-news.com](http://www.unimog-e-news.com)  
[www.mercedes-benz.co.uk](http://www.mercedes-benz.co.uk)

## What you may expect from Mercedes-Benz

- + First class quality service at over 650 locations in over 130 countries worldwide
- + Maintenance, trouble diagnosis and repairs
- + Technical advice and customer care
- + Advice and instruction on usage
- + Driving, safety and technical instruction
- + Acting fairly

## Efficient high-performance service offers from Mercedes-Benz Special Trucks

- + **Service Contracts:** Including any wear and tear items (excluding attachments and mounted bodies)

Your Unimog Dealer will be happy to give you more information about our attractive service offers.

# Models and versions

A strong team. The new Unimog implement carrier

Model	U 216	U 218	U 318	U 423	
Model type	C 405.090	C 405.090	C 405.104	C 405.105	C 405.125
Wheelbase	2800 mm	2800 mm	3000 mm	3000 mm	3600 mm
Engine (Euro VI)	OM 934	OM 934	OM 934	OM 934	OM 934
Output kW/hp	115/156	130/177	130/177	170/231	170/231
Torque Nm/rpm	650/1200-1600	750/1200-1600	750/1200-1600	900/1200-1600	900/1200-1600
Clutch	Single-plate dry clutch. SAE2 Ø 395 press-formed				
Transmission	UG 100/8 with integrated transfer case				
Axles	Link-located portal axles with coil springs				
Front axle	AU 4/3 CS 5.1	AU 4/3 CS 5.1	AU 4/3 CS 5.1	AU 5/5 CS 7.0	AU 5/5 CS 7.0
Rear axle	HU 4/3 CS 5.5	HU 4/3 CS 5.5	HU 4/3 CS 5.5	HU 5/5 CS 8.0	HU 5/5 CS 8.0
Electrical system	24 V	24 V	24 V	24 V	24 V
Battery capacity	140 Ah	140 Ah	140 Ah	140 Ah	140 Ah
Tank capacity (fuel tank) (Series/SA)	145 l	145 l	145 l	145 l/200 l	200 l/250 l
Tank capacity (AdBlue)	18 l	18 l	25 l	25 l	25 l
Steering with max. steering pressure	ZF 8095/170 bar	ZF 8095/170 bar	ZF 8095/170 bar	ZF 8098/150 bar	ZF 8098/150 bar
Brakes	Pneumatic disc brakes				
Smallest tyres (tyre/rim)	295/60 R22.5	295/60 R22.5	315/80 R22.5	335/80 R20	335/80 R20
Largest tyres (tyre/rim)	405/70 R20	405/70 R20	425/75 R20	445/70 R24	445/70 R24
Type of drive (permanent all-wheel drive)	4x4	4x4	4x4	4x4	4x4
Maximum weight (max. with corresponding optional extras)	10.0 t	10.0 t	11.0 t	13.8 t	14.0 t
Max. weight on front axle	5.2 t	5.2 t	5.5 t	6.9 t	7 t
Max. weight on rear axle	5.5 t	5.5 t	6.0 t	7.8 t	8.0 t
Angle of approach at the front with large tyres	25°	25°	27°	33°	33°
Turning circle	12.6 m	12.6 m	13.7 m	13.7 m	16.5 m
Minimum vehicle dimensions: length×width×height	4900×2150×2820 mm	4900×2150×2820 mm	5100×2150×2870 mm	5100×2200×2900 mm	5600×2200×2900 mm
Inside dimensions dumper body	2200×2075×400 mm	2200×2075×400 mm	2385×2075×400 mm	2385×2075×400 mm	2900×2075×400 mm
Speed	89 km/h *				

\* Limited, legal speed limit

U 427	U 430	U 527	U 530				
C 405.110	C 405.125	C 405.110	C 405.125	C 405.202	C 405.222	C 405.202	C 405.222
3150 mm	3600 mm	3150 mm	3600 mm	3350 mm	3900 mm	3350 mm	3900 mm
OM 936	OM 936	OM 936	OM 936	OM 936	OM 936	OM 936	OM 936
200/272	200/272	220/299	220/299	200/272	200/272	220/299	220/299
1100/1200-1600	1100/1200-1600	1200/1200-1600	1200/1200-1600	1100/1200-1600	1100/1200-1600	1200/1200-1600	1200/1200-1600
Single-plate dry clutch. SAE2 Ø 395 press-formed							
UG 100/8 with integrated transfer case							
Link-located portal axles with coil springs							
AU 5/5 CS 7.0	AU 5/5 CS 7.0	AU 5/5 CS 7.0	AU 5/5 CS 7.0	AU 6/1 CS 7.5	AU 6/1 CS 7.5	AU 6/1 CS 7.5	AU 6/1 CS 7.5
HU 5/5 CS 8.0	HU 5/5 CS 8.0	HU 5/5 CS 8.0	HU 5/5 CS 8.0	HU 6/1 CS 9.5	HU 6/1 CS 9.5	HU 6/1 CS 9.5	HU 6/1 CS 9.5
24 V	24 V	24 V	24 V	24 V	24 V	24 V	24 V
140 Ah	140 Ah	140 Ah	140 Ah	140 Ah	140 Ah	140 Ah	140 Ah
200 l/250 l	200 l/250 l	200 l/250 l	200 l/250 l	200 l/250 l	200 l/250 l	200 l/250 l	200 l/250 l
25 l	25 l	25 l	25 l	25 l	25 l	25 l	25 l
ZF 8098/150 bar	ZF 8098/150 bar	ZF 8098/150 bar	ZF 8098/150 bar	ZF 8098/160 bar	ZF 8098/160 bar	ZF 8098/160 bar	ZF 8098/160 bar
Pneumatic disc brakes							
335/80 R20	335/80 R20	335/80 R20	335/80 R20	305/70 R22.5	305/70 R22.5	305/70 R22.5	305/70 R22.5
445/70 R24	445/70 R24	445/70 R24	445/70 R24	495/70 R24	495/70 R24	495/70 R24	495/70 R24
4x4	4x4	4x4	4x4	4x4	4x4	4x4	4x4
14.0 t	14.0 t	14.0 t	14.0 t	16.5 t	16.5 t	16.5 t	16.5 t
7.0 t	7.0 t	7.0 t	7.0 t	7.5 t	7.5 t	7.5 t	7.5 t
8.0 t	8.0 t	8.0 t	8.0 t	9.5 t	9.5 t	9.5 t	9.5 t
33°	33°	33°	33°	35°	35°	35°	35°
14.3 m	16.5 m	14.3 m	16.5 m	15.1 m	16.9 m	15.1 m	16.9 m
5150×2200×2900 mm	5600×2200×2900 mm	5150×2200×2900 mm	5600×2200×2900 mm	5550×2300×2970 mm	6200×2300×2970 mm	5550×2300×2970 mm	6200×2300×2970 mm
2385×2075×400 mm	2900×2075×400 mm	2385×2075×400 mm	2900×2075×400 mm	2650×2200×400 mm	3430×2200×400 mm	2650×2200×400 mm	3430×2200×400 mm
89 km/h *							

**Please note:** Changes may have been made to the product since this brochure went to press (22.03.2013). The manufacturer reserves the right to make changes to the design, form, colour and specification during the delivery period, provided these changes, while taking into account the interests of the vendor, can be deemed reasonable with respect to the purchaser. Where the vendor or the manufacturer uses symbols or numbers to describe an order or the subject of an order, no rights may be derived solely from these. The illustrations may show accessories and items of special equipment which are not part of standard specification. Colours may differ slightly from those shown in the brochure, owing to the limitations of the printing process. This brochure may also contain models and services which are not available in certain countries. This brochure is distributed internationally. It provides a general indication of the range of models, features, special equipment and/or colours available in various countries. Some of the models, features, special equipment and/or colours may not be available in your country, or may only be available in a different specification. Additionally some models, features, special equipment and/or colours may only be available in combination with others. For current and more specific information relating to the range of models, features, special equipment and/or colours available in your country, and their pricing, you should contact your nearest Mercedes-Benz Dealer. [www.mercedes-benz.co.uk](http://www.mercedes-benz.co.uk)