



> View price list



> View offers



Book a > test drive > AMG test drive



> Mercedes-Benz Magazine

# G-Class



Mercedes-Benz





> View price list



> View offers



Book a > test drive > AMG test drive



> Mercedes-Benz Magazine

## The G-Class. There's nothing to add.

Please take a seat. Or, perhaps better, climb into a car that has everything you'd expect of a Mercedes-Benz: dynamic performance, comfort, safety and status. The G-Class continues to modernise, featuring the latest technical advances and innovations, yet it's firmly rooted in a great off-road tradition. That's true for the classic design, robust construction and, of course, a penchant for extreme terrain. The G-Class is the only Mercedes that feels equally at home on the road as off it. A reliable teammate for any adventure, on glamorous boulevards or mountain ridges. Proof that being down-to-earth can make you feel on top of the world.





> View price list



> View offers



Book a > test drive > AMG test drive



> Mercedes-Benz Magazine

#### Featured models at a glance:

##### 4 | Mercedes-Benz G 63 AMG 4MATIC

###### *designo* Magno Platinum

AMG 5-twin-spoke alloy wheels, *designo* leather in Sand, AMG carbon fibre trim

##### 27 | Mercedes-Benz G 350 BlueTEC 4MATIC

###### Magnetite Black

5-twin-spoke alloy wheels, *designo* leather in Porcelain, *designo* Black Piano Lacquer trim

Illustrations may show accessories or items of optional equipment which are not part of standard specification.

#### Vision

12 | Innovation that moves

#### Engines and suspension

13 | BlueTEC diesel engine

15 | AMG V8 petrol engine

17 | Transmissions

19 | Suspension

21 | On- and off-road technology

#### Safety

25 | Integrated safety concept

#### G-Class design and AMG

27 | G-Class design

29 | G 63 AMG 4MATIC

#### Comfort

31 | Multimedia systems

32 | Parking aids

#### Equipment

33 | Standard equipment

34 | Optional extras

35 | Option packages

41 | Upholstery and trim

44 | *designo*

49 | Alloy wheels

#### 50 | Services

#### Facts and finishes

52 | Dimensions

53 | Technical specifications

54 | Paint finishes





> View price list



> View offers



Book a > test drive > AMG test drive



> Mercedes-Benz Magazine



## Making its own way - a path the G-Class will never divert from.

Changing without changing. Building a new G-Class that stays true to its heritage, that's a great challenge. The result is a legend continued.





> View price list



> View offers



Book a > test drive > AMG test drive



> Mercedes-Benz Magazine

# All-terrain is not an ability – it's an attitude.

Unique challenges require special solutions: engines with the volume and performance to suit the special demands of an all-terrain vehicle, and 100% differential locks to help the G-Class adapt to nearly any kind of road and driving condition. → pages 13–16, 21–24





> View price list



> View offers



Book a > test drive > AMG test drive



> Mercedes-Benz Magazine

## Also designed for the Hollywood Hills.

Whether you're cruising down Bel Air or tackling the Mojave desert, the G-Class happily swaps the red carpet for red sand. It's designed for extremes, effortlessly mastering spontaneous changes of scenery. So wherever your imagination takes you, the G-Class is with you all the way.





> View price list



> View offers



Book a > test drive > AMG test drive



> Mercedes-Benz Magazine



# Some cars have long memories. They remember the days before tarmac.

Climb, wade, scramble, plough, drift – you wouldn't normally expect a car to perform these activities. Unless it's a G-Class. This Mercedes welcomes any challenge. It's always behind you, even when everyone else seems to have deserted.

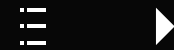
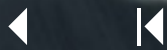



> View price list



> View offers



Book a > test drive > AMG test drive



> Mercedes-Benz Magazine

At home where even  
dreams don't reach.







> View price list



> View offers



Book a > test drive > AMG test drive



> Mercedes-Benz Magazine



# The perfect space for the upper echelons.

If you're reaching for the top, get on board the G-Class and you're half way there. The higher seating position, the ergonomic seat design and first-class comfort all make you feel like a king – whether you're on the road or off, on the way to a mountain top or to an economic summit.





> View price list



> View offers



Book a > test drive > AMG test drive



> Mercedes-Benz Magazine

# [gə'ləndəvaxgən]

Nothing conjures up images like the term 'Geländewagen', the German word for cross-country vehicle. The mind instantly creates its very own motion picture, taking you through deserts, up steep mountain passages, surveying vast terrains yet to be explored. Your eyes are dry with sand, your skin parched by the sun, your whole body exhausted

by the strenuous journey, yet the G-Class remains unfazed, confidently mastering each task and obstacle you present it with. Wherever your imagination takes you, the main protagonist stays the same. Because if you think Geländewagen, there's nothing like the Mercedes-Benz G-Class. Don't just think off-road, think off-the-norm...





> View price list



> View offers



Book a > test drive > AMG test drive



> Mercedes-Benz Magazine

## The stuff that legends are made of.

Deutschmann nods. This slow, carefully considered movement marks his approval and perhaps the most important nod in the Grazer mountain region.

A few members of his team have observed him, only to quickly return their gaze to their work. Up to 45,985 stitches, countless cuts and folds require full concentration and absolute precision. And, finally, that scrutinising gaze. For 33 years, Herr Deutschmann has been casting his eyes over every G-Class. When he nods, it means “excellent work.” If he doesn’t, the results won’t ever see the light of the picturesque Austrian mountain day.

Up to 810 metres of yarn spin around the G-Class, holding together the body and soul of this mountaineering expert. There are no superfluous loops, not a stitch a millimetre out – proof of pure passion at work. To spur on the master craftsmen, pin-ups adorn the studio – not with images of scantily clad ladies, but with the full-bodied G-Class. A Mercedes through and through.





## What makes a car a Mercedes?

Tradition comes with responsibility. To us, it means commitment to innovation. We have always explored uncharted territory, setting milestones all along the way: the first vehicle with a crumple zone, the first ABS, the first diesel car or, indeed, the first car. But why dwell on the past, when there's so much to look forward to?

**Mercedes me** – welcome to a world that revolves around you. For us, the focus is on people. To pursue this responsibility we have developed a new platform to enable your own personal contact with Mercedes-Benz, with individual services that are made for you. *Connect me* connects the vehicle with your adventure world, with everything that is important to you. *Move me* offers new mobility solutions. And with *Inspire me*, we provide an exclusive glimpse into the future of mobility. Your access to a fascinating world: [www.mercedes.me](http://www.mercedes.me)



**Mercedes-Benz Intelligent Drive** – our vision of accident-free driving. At its heart are intelligent technologies actively supporting the driver and increasing the driver's comfort. Crucial electronic assistants are already at work in your Mercedes-Benz, automatically helping to keep the car at a safe distance from the vehicle in front, braking when necessary and warning the driver of impending rear-end collisions or of vehicles in the blind spot. By intelligently combining sensors of safety systems and electronic assistants, potentially dangerous situations are identified much earlier and are consequently ever more frequently avoided. To discover the pioneering world of Mercedes-Benz Intelligent Drive visit [www.mercedes-benz-intelligent-drive.com](http://www.mercedes-benz-intelligent-drive.com)

**BlueEFFICIENCY** – our vision of zero-emission driving. While 'sustainability' is a big word, we lend it real meaning in everything we do. From the most eco-friendly manufacturing process possible through to alternative drive concepts.

As you can see, we've set ourselves far-reaching goals. But what could be more pleasant than to enjoy the journey in a Mercedes-Benz?

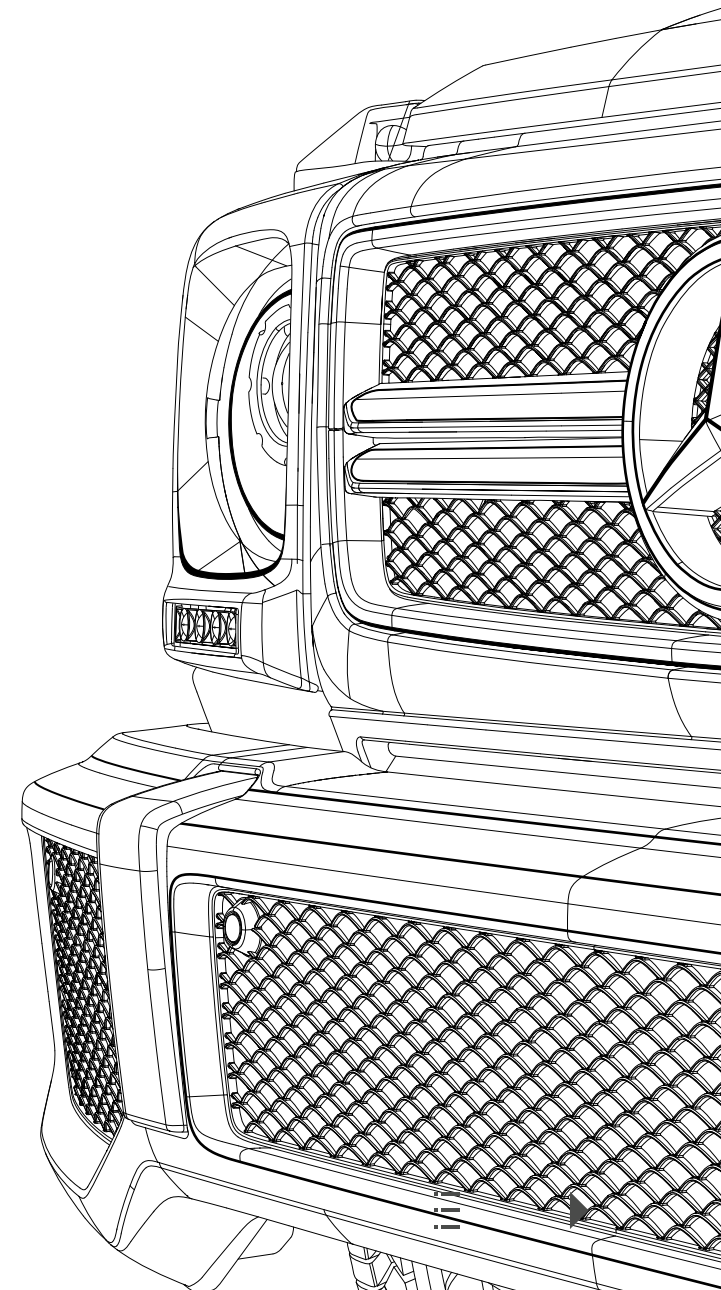



## BlueTEC diesel engine

With its impressive levels of low-range torque, the G 350 BlueTEC 4MATIC's V6 diesel engine gives you the pulling power you need when tackling tough terrain.

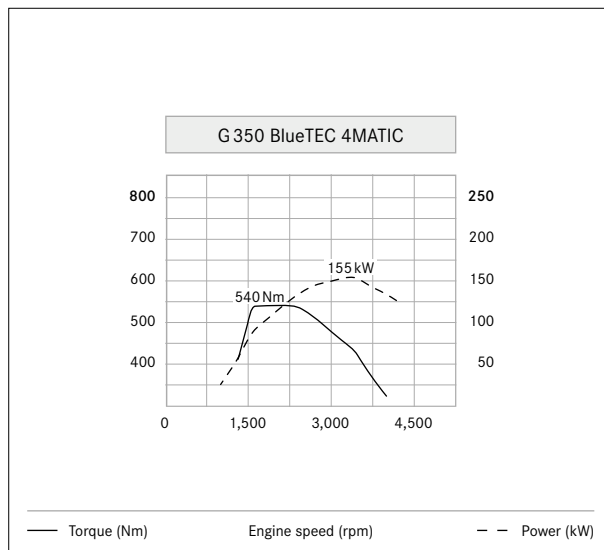

The maximum 540 Nm of torque is available from just 1,600 to 2,400 rpm

The G 350 BlueTEC 4MATIC's V6 common-rail diesel engine delivers 211 hp (155 kW) combined with excellent fuel efficiency, while the combination of precise piezo injectors, injection pressures of up to 1,600 bar, and an optimised turbocharger help it to generate an impressive 540 Nm of torque. What's more, the G 350 BlueTEC 4MATIC features a state-of-the-art catalytic converter system and uses the urea-based additive AdBlue® to clean and treat exhaust emissions, helping to reduce NOx emissions by up to 80%. A warning will appear in the instrument panel if the car is running low on AdBlue®, which can then be topped up in the same way as fuel. ISO 22241-compliant AdBlue® refill canisters are available from your Mercedes-Benz Retailer.





> View price list



> View offers



Book a > test drive > AMG test drive



> Mercedes-Benz Magazine



The G350 BlueTEC 4MATIC's diesel V6 engine offers effortless pulling power in all situations, combined with excellent fuel efficiency and low emissions





# AMG V8 petrol engine

The AMG biturbo V8 engine gives the G 63 AMG 4MATIC exhilarating on-road performance to go with its exceptional off-road ability.

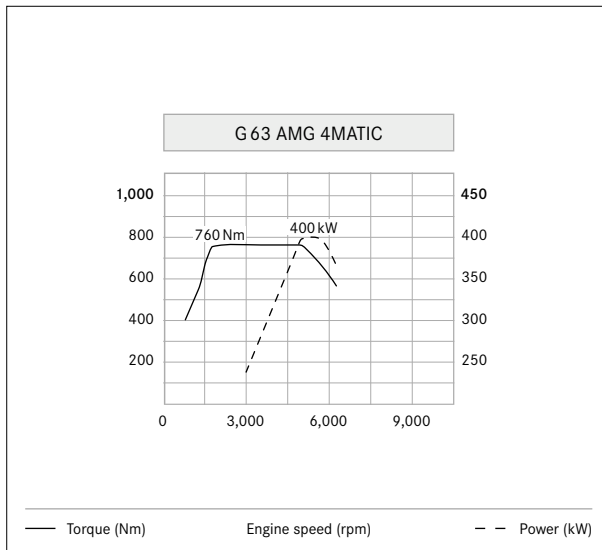

With its free-revving AMG 5.5-litre biturbo V8 delivering 544 hp (400 kW) plus a maximum 760 Nm of torque, the G 63 AMG 4MATIC offers class-leading on-road performance. It sprints from 0 to 62 mph in just 5.4 seconds and goes on to an electronically limited top speed of 130 mph. What's more, it not only gives you even more power than its predecessor, it also offers significantly improved fuel consumption, thanks to technology such as spray-guided direct petrol injection, piezo injectors, twin turbochargers, variable camshaft control, intercooling and ECO start/stop.

The G 63 AMG 4MATIC offers a mighty 760 Nm of torque all the way from 2,000 to 5,000 rpm





> View price list



> View offers



Book a > test drive > AMG test drive



> Mercedes-Benz Magazine

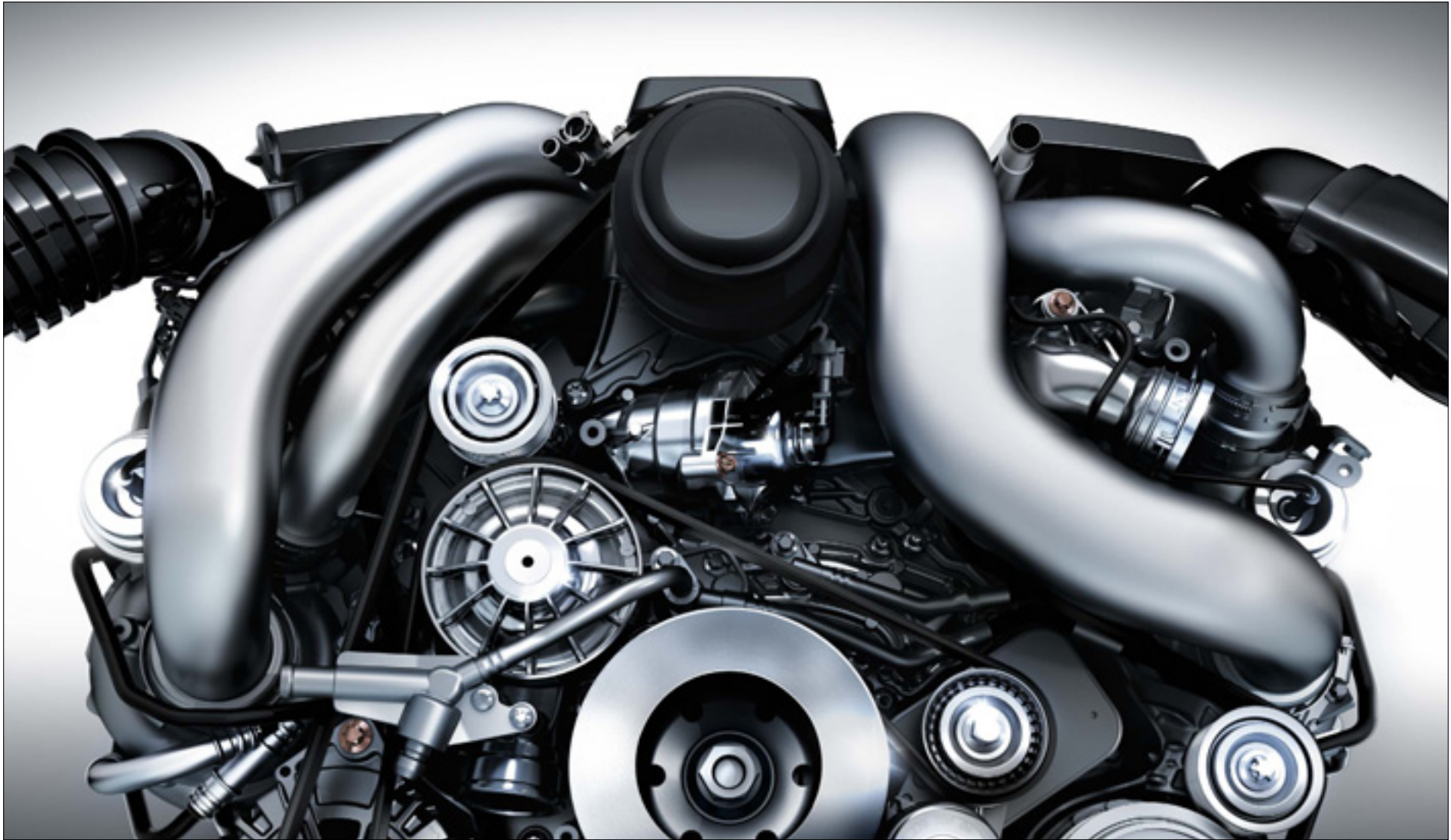

This high-performance engine satisfies even the keenest of drivers – without sacrificing fuel efficiency

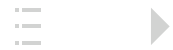
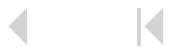





## Transmissions

Designed for dynamic on-road performance and effortless off-roading, the 7-speed transmissions are carefully matched to their respective engines. What's more, they adapt automatically to different situations and driving styles.

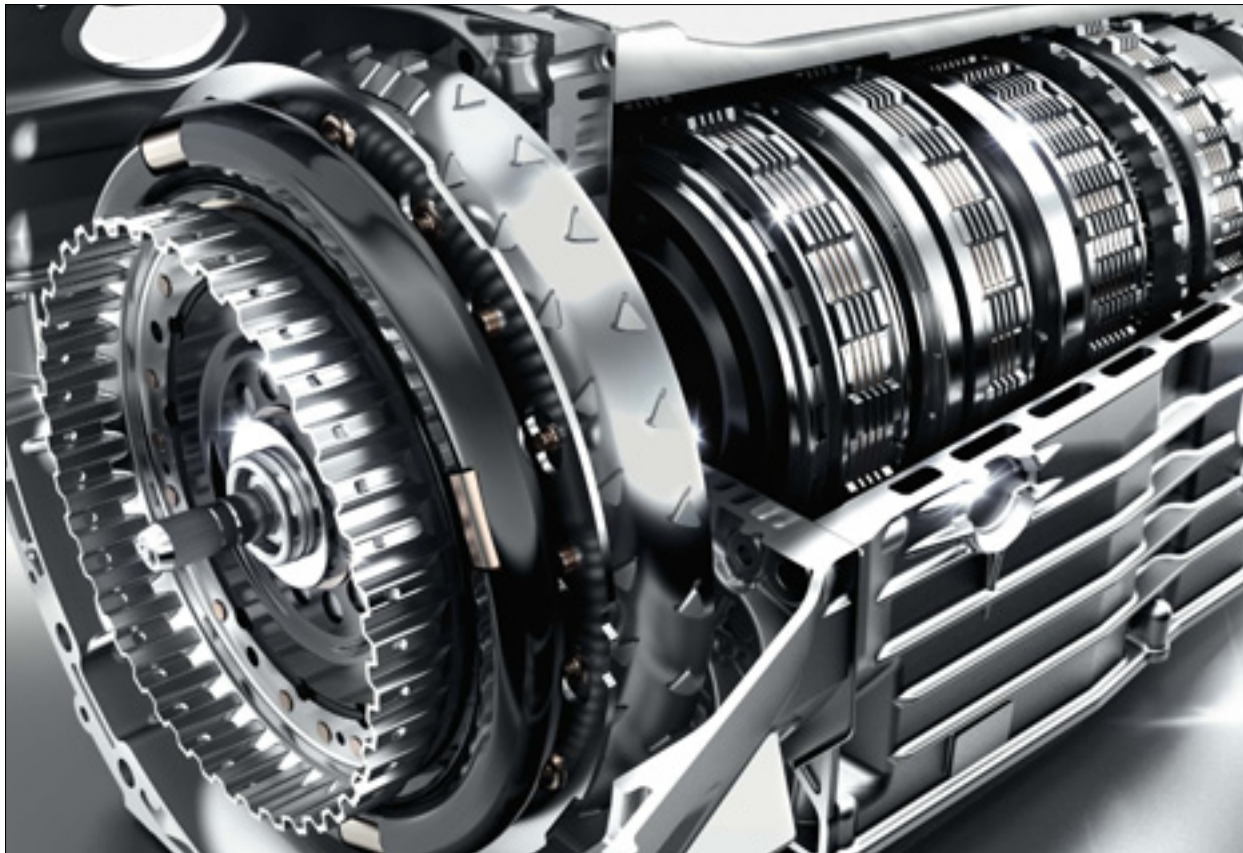

**7G-Tronic Plus** (standard on G 350 BlueTEC 4MATIC). With its exceptionally smooth gear changes, this 7-speed automatic transmission makes for a more effortless and enjoyable drive. The seven forward gears allow for ideally spaced ratios and ensure the engine is always operating at the ideal engine speed, resulting in almost imperceptible shifts as well as noticeably lower fuel consumption and noise levels. In kickdown, 7G-Tronic Plus can also skip individual gears for a more rapid response, jumping from seventh to fifth when overtaking for instance, while the extremely short shift times help to further enhance performance, giving you better off-roading, climbing and towing ability.

The G 350 BlueTEC 4MATIC's 7G-Tronic Plus 7-speed transmission offers supremely smooth gear changes





> View price list



> View offers



Book a > test drive > AMG test drive



> Mercedes-Benz Magazine



**AMG Speedshift Plus 7G-Tronic** (standard on G 63 AMG 4MATIC). The G 63 AMG 4MATIC marks the G-Class debut of our AMG Speedshift Plus 7G-Tronic system, the state of the art in Mercedes-Benz transmission technology. This updated 7-speed automatic transmission is designed to cope with exceptionally high levels of torque, ensuring the G 63 AMG 4MATIC's 760 Nm is transferred smoothly and rapidly to the driven wheels. What's more, it offers exceptionally short shift times and uninterrupted acceleration.

**ECO start/stop function** (standard on G 63 AMG 4MATIC). Active in 'Controlled Efficiency' ('C') mode, the ECO start/stop function helps the G 63 AMG 4MATIC to achieve impressively low levels of fuel consumption by cutting the engine whenever the vehicle comes to a standstill. In addition, 'C' mode ensures you always pull away in second and benefit from earlier shift points – meaning enhanced low-range torque, greater fuel efficiency and lower CO<sub>2</sub> emissions.

AMG Speedshift Plus 7G-Tronic transmission ensures the G 63 AMG 4MATIC's power is harnessed as effectively as possible





## Suspension

With its ladder-type frame, long-travel rigid-axle suspension and 21 cm of ground clearance, the G-Class takes almost any surface and obstacle in its stride.

**Ladder-type frame.** Its separate ladder-type chassis makes the G-Class tougher and more stress-resistant than off-roaders with unibody construction, helping to enhance longevity and resale value. Consisting of two parallel box-section members joined together via cross-members, the frame has a flexural strength that is particularly valuable in prolonged off-road use. The bodywork is screwed to the frame at eight different points and insulated from it via vibration-suppressing rubber bearings. For optimum corrosion resistance, the frame is powder-coated, surface

treated and painted. All hollow sections are waxed, while body panels are cathodic dip painted and the underbody benefits from an additional plastic coating. As a result, the body is thoroughly protected against snow, salt and even Saharan sand. A key advantage of the highly rigid ladder frame can be seen in situations exerting high levels of torsional twist, with the chassis able to absorb twist forces so that these are not transferred to the bodywork. In addition, the fact that the ladder frame is always the lowest part of the body, with only the axles protruding

below it, helps to protect key components if the body comes into contact with the ground when off-roading.

**Steering.** The G-Class power steering is specially designed to meet the requirements of off-road driving. The absence of more easily worn parts such as steering gaiters and rubber bellows enhances durability and longevity, while the power assistance reduces effort compared with traditional recirculating ball systems and also softens the shocks to the driver's hand when driving over obstacles.



The ladder-type frame gives the G-Class exceptional stability and longevity

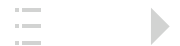



> View price list



> View offers



Book a > test drive > AMG test drive



> Mercedes-Benz Magazine

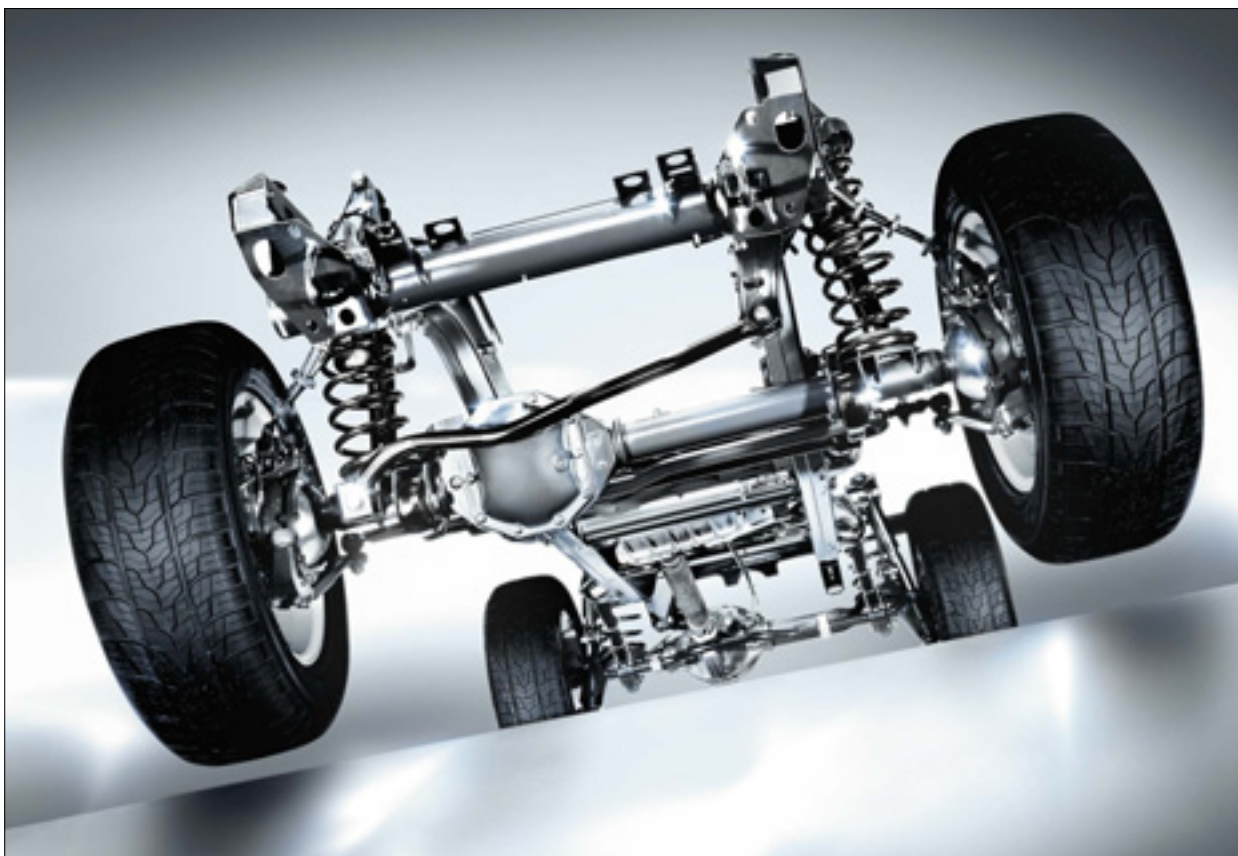

**Rigid-axle suspension.** In off-road driving, the G-Class suspension, which features rigid axles with two solid trailing arms and a single control arm per axle, offers numerous advantages over road-biased independent suspension. Long-travel coil springs allow for a high degree of torsional twist, excellent ground clearance and outstanding traction, and also provide an agile and comfortable drive on tarmac. Gas struts help to prevent excess oscillation, twin anti-roll bars tailored to the vehicle's performance, unladen weight and payload capacity ensure lower levels of lean than on many off-roaders, and rigid steel shafts front and rear ensure the wheel camber on each axle remains unchanged. In addition, the even distribution of wheel load per axle, together with the ability to cope with higher angles of twist, increases durability, ensures ground clearance is unaffected by large obstacles and helps to maximise traction on demanding terrain.

Rigid axles ensure high durability even with heavy off-road use, whilst maximising traction and enabling the vehicle's ground clearance to be maintained





## On- and off-road technology

The G-Class offers outstanding off-road capabilities and keeps you moving even in tough terrain.

### 4MATIC permanent four-wheel drive with 4ETS.

Working in harmony with the Four-wheel Electronic Traction System (4ETS), three fully locking differentials and a synchromesh transfer case with off-road ratio, the G-Class four-wheel drive system provides optimum traction at all wheels, along with enhanced handling and stability. Its 50:50 torque split distributes power evenly between the front and rear wheels, while the differential gear system compensates for differences in rotational speed between the wheels, ensuring power is translated effectively into performance.

Part of the ESP® system, 4ETS can brake spinning wheels individually and direct the torque to the wheel or wheels offering the best traction in any given situation. As a result, the G-Class can pull away and accelerate even on difficult surfaces such as icy roads or tracks. In more rugged terrain, the rigid axles provide excellent ground clearance and outstanding traction, enabling you to get the best out of the permanent four-wheel drive system.

**Locking differentials.** Three electro-mechanically lockable differentials allow the G-Class to make headway even when only one of its wheels has traction. In tough terrain, buttons on the dashboard allow the front, centre and rear differentials to be locked sequentially according to your traction requirements. 4ETS and ESP® are automatically disengaged when the differentials are activated. Locking all three differentials ensures the front and rear axles and the individual wheels on each axle are all turning at exactly the same speed, thus enabling the G-Class to extricate itself from tricky off-road situations using the traction of just a single wheel. The differential locks can be engaged while in high or low transmission range for added convenience.

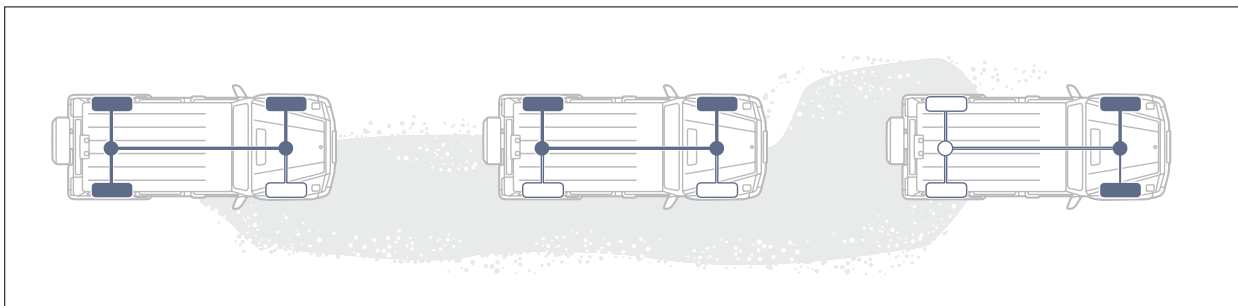

The Four-wheel Electronic Traction System (4ETS) automatically transfers torque to the wheels with the most traction





> View price list



> View offers



Book a > test drive > AMG test drive



> Mercedes-Benz Magazine



RADIO



**Off-road ratio** (figures based on standard specification). Activated at speeds of approx. 25 mph or below by simply pressing the 'low range' button when in neutral, the 2-speed transfer case's off-road ratio is a real advantage when tackling tough terrain. By optimising torque

transfer at low speeds and thus improving pulling power and traction, it allows the G-Class to climb gradients of up to 100% (AMG model 80%) and tackle difficult descents without locking the wheels. The off-road ratio is particularly useful on slopes with slippery or varying

surfaces such as rock, grass or snow, helping to maximise stability, maintain steerability and prevent the rear from breaking out.

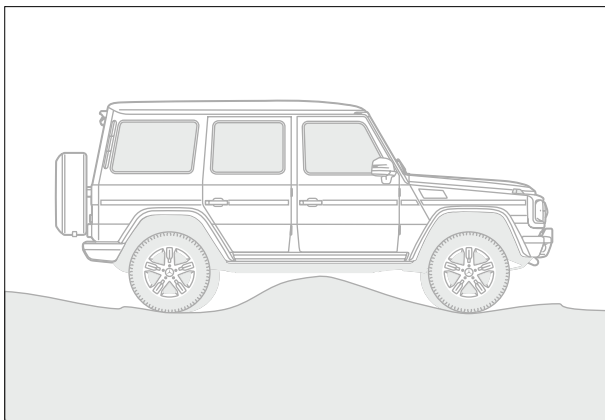

Ground clearance of 21 cm (22 cm on G 63 AMG 4MATIC)

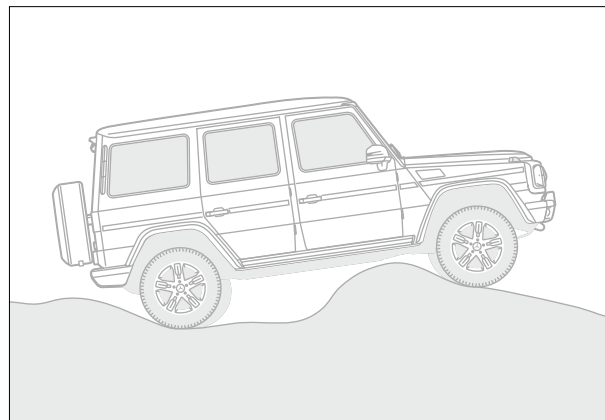

Large ramp breakover angle of 24°

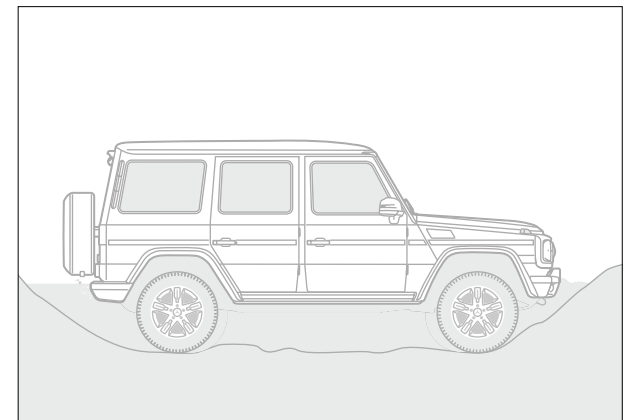

Maximum fording depth of 60 cm





**Unique G-Class attributes.** Only the G-Class offers the combination of 4ETS, 2-speed transfer case and three fully lockable differentials. Add in the two rigid axles and a protected drivetrain and you have a vehicle capable of tackling almost any terrain and coping with extremely

high levels of torsional twist. The G-Class climbs gradients of up to 80% (surface permitting), traverses slopes of up to 54% and fords up to 60 cm of water and mud. In addition, it boasts a ground clearance of 21 cm (22 cm on G 63 AMG 4MATIC), with a correspondingly high

breakover angle, and offers approach and departure angles of 36° (27° for G 63 AMG 4MATIC) and 27° respectively.

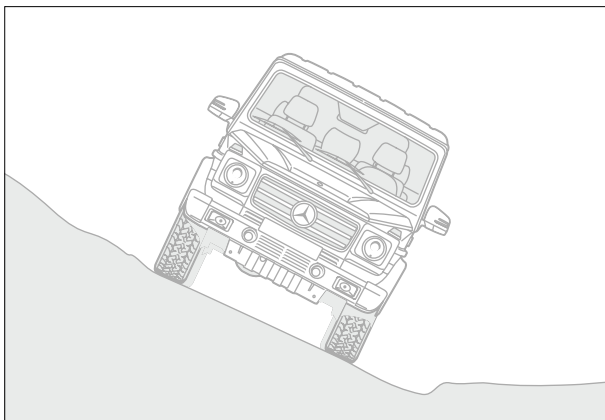

Directionally stable on slopes of up to 54%

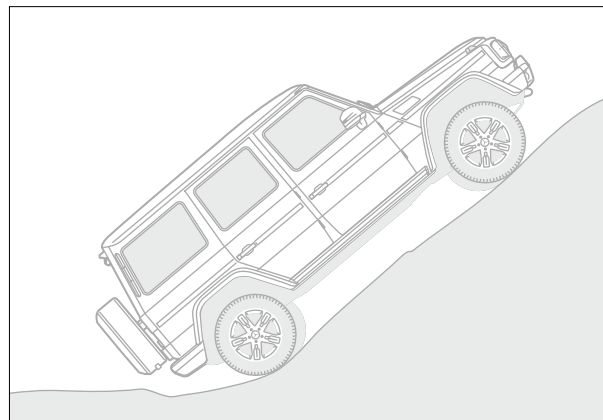

Climbs gradients of up to 80% (surface permitting)

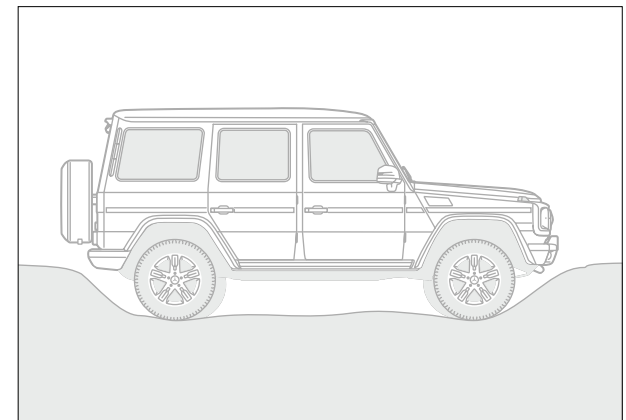

Max. approach angle 36° (27° for G 63 AMG 4MATIC), max. departure angle 27°

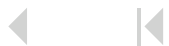





## Integrated safety concept

The vision of accident-free driving spurs us on. Our integrated safety system makes way for a comprehensive approach to maximise safety in every road situation.

**Electronic braking aids** (standard). The Electronic Stability Programme (ESP®) can apply the brakes individually as the situation requires and, together with the anti-lock braking system (ABS), increase stability when cornering. It also optimises stability when towing, helping to counter trailer sway via the integral Trailer Stability Assist function. Also fitted as standard is the Adaptive Brake System, whose hold function helps to prevent the vehicle from creeping forwards at traffic lights or in stop/start driving, and Brake Assist (BAS), which can detect emergency braking and ensure sufficient braking pressure is applied.

**LED daytime running lights** (standard). Visually striking and more immediately visible, LED daytime running lights enhance both safety and style. Their LED strips are situated beneath the headlamps and housed within the headlamp casings.

**Neck-Pro comfort head restraints** (standard). In the event of a rear-end collision, the Neck-Pro comfort front head restraints are raised approximately 30 millimetres and moved forward about 40 millimetres, ensuring the head is better supported and reducing the risk of whiplash injuries. In addition, they feature flexible side bolsters that further enhance side support and comfort.

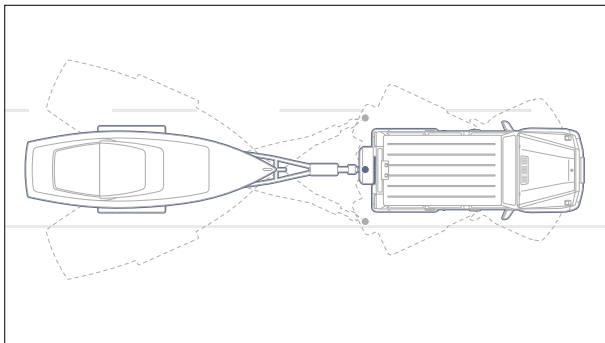

Trailer Stability Assist helps to increase safety when towing



LED daytime running lights enhance visibility and emphasise the distinctive G-Class looks

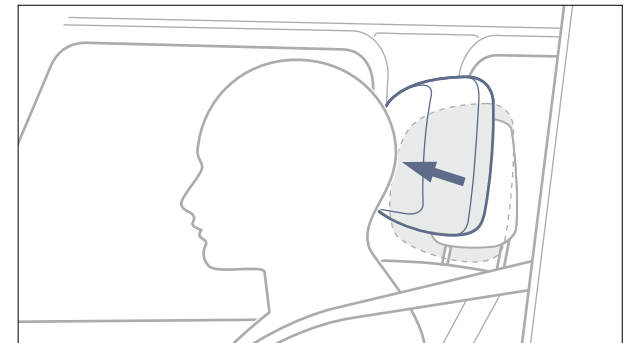

Neck-Pro comfort head restraints can reduce the risk of whiplash injury in rear-end collisions





**Airbags and windowbags** (standard). The G-Class is fitted with front and side airbags for the driver and front seat passenger plus windowbags for both rows of seats. The passenger's side airbag includes a seat occupancy sensor, while the driver's side airbag features dual-stage activation, inflating either partially or fully depending on the type and projected severity of the impact.

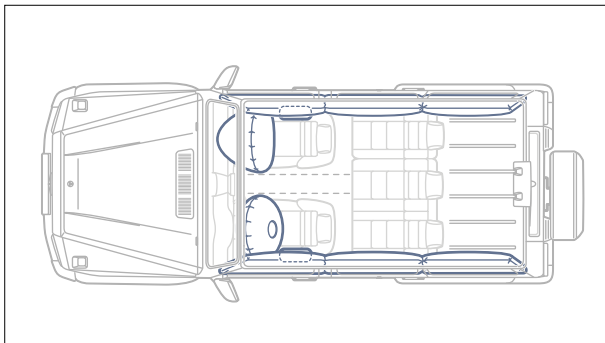

Airbags for the driver and front seat passenger and windowbags for both rows of seats are fitted as standard

**Distronic Plus** (optional as part of the Driving Assistance Package). This radar-assisted cruise control system automatically maintains a preset distance from the vehicle in front, accelerating and braking automatically, thus making for more relaxed progress in high-speed driving or stop/start traffic. What's more, the heated radar sensor ensures it remains fully functional even in ice or snow. If the gap starts to decrease too rapidly, Distronic Plus emits an acoustic warning, while Brake Assist (BAS) intervenes if it detects emergency braking, ensuring sufficient brake force is applied.



Distronic Plus radar-assisted cruise control automatically maintains a set distance from the vehicle in front

**Blind Spot Assist** (optional as part of the Driving Assistance Package). Active at speeds of above 19 mph, Blind Spot Assist monitors the hard-to-see areas to the rear and sides of the car. If it spots a potentially dangerous lane change, the system alerts the driver via a warning signal in the corresponding exterior mirror. If the driver then switches on the indicator on that side, an additional acoustic warning is sounded.



Blind Spot Assist helps you to avoid dangerous lane changes





## G-Class design

Timeless looks and peerless versatility have made the G-Class a legend among off-roaders.

Styles come and go, but the G-Class simply endures. Now in its fourth decade, it boasts the same classic lines and clean surfaces that have always made it such a unique presence. Its large glass area features distinctively shaped load compartment windows, the side skirts, shoulder lines, roof lines and side rubbing strips are almost exactly parallel, and the high wheel arches and wide track, together with a rear that's slightly thicker at the base,

add up to a sturdy-looking body with optimum off-road ability. Inside, the spacious G-Class cabin is supremely comfortable whatever the distance or weather, thanks to a 2,850 mm wheelbase, heat-insulating glass all round, and standard features such as heated seats front and rear. The G-Class accommodates equipment with ease too, offering up to 2,250 litres of luggage capacity and easy access via the large side-hinged tailgate. The standard

1/3:2/3 split folding rear seat and load-securing points further enhance its versatility, while the optional load compartment cover and luggage net help to keep your cargo safe and secure. What's more, with a maximum trailer load of 3.5 tonnes, the G-Class even enables you to tow boats, horseboxes or caravans over difficult surfaces.



Clean lines and distinctive style



Extreme durability combined with exceptional comfort



Space for all your equipment, whatever the expedition





> View price list



> View offers



Book a > test drive > AMG test drive



> Mercedes-Benz Magazine





## G 63 AMG 4MATIC

AMG technology meets go-anywhere ability – discover a driving experience without comparison. → [www.mercedes-benz.co.uk/amg](http://www.mercedes-benz.co.uk/amg)



With 544 hp (400 kW) from its AMG biturbo V8, 760 Nm of torque and fuel-saving features such as ECO start/stop, the G 63 AMG 4MATIC is a remarkable combination of exhilaration and efficiency. Visually, it's simply unmistakable, thanks to the AMG two-bar grille with chrome trim, AMG wheel arch extensions, 'V8 BITURBO' badges on the front wings, privacy glass and an AMG exhaust system with side-exiting twin chromed tailpipes. Also fitted as standard are the Exterior Styling Package and AMG 5-twin-spoke alloy wheels with Titanium Grey finish, red-painted brake calipers, a tow bar and 275/50 R 20 tyres.

The cabin is similarly special, with illuminated AMG stainless steel door sill panels, *designo* leather upholstery, leather trim for the dashboard, *designo* Black Piano Lacquer trim, door panels in ruffled leather, a Black Dinamica microfibre roof lining and AMG Performance steering wheel. Ventilated multi-contour seats, ambient interior lighting and a twin bottle holder in the rear add to the relaxed and comfortable journey. You'll also find new features including front side airbags, a tyre pressure monitoring system plus reversing camera. And there is more: a choice of two *designo* wood trims or the option of AMG carbon fibre trim for an even more dynamic look.





> View price list



> View offers



Book a > test drive > AMG test drive



> Mercedes-Benz Magazine

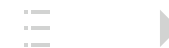



## Multimedia systems

The G-Class multimedia systems help you to reach your destination as directly as possible – and keep you and your passengers entertained on the way.

**COMAND Online system** (standard). The COMAND Online system combines navigation, communication and Internet functions with a wide range of in-car entertainment features. These include a DVD drive, tuner, music library with a 10 GB hard drive, plus a Media Interface that allows connection of external devices, Bluetooth® interface and an SD memory card slot. The system can be operated via spoken commands courtesy of Linguatronic voice control and, in conjunction with an Internet-ready mobile phone, offers access to the Internet and to Mercedes-Benz apps. The latest version also shows a photorealistic map

display, and features Windows and iPhone® compatibility plus Internet radio. As an option, you can even equip your G-Class with a TV tuner and watch television on the COMAND Online display.

**Harman Kardon® Logic 7® surround sound system** (standard). With its 10-channel DSP amplifier, 450-watt output and 3D spatial sound, this 12 high-performance speaker system delivers a first-class listening experience for all. It also features Dolby Digital 5.1 and speed-sensitive volume adjustment for optimum clarity and enjoyment.

**Rear seat entertainment system** (optional as part of the Entertainment Package). This entertainment system gives rear seat passengers everything they need to watch films or use a games console without disturbing the driver. It comprises two independently-operable 7-inch TFT colour displays attached to the backs of the front seat head restraints, two integrated DVD players, two sets of wireless headphones, a remote control and twin aux-in sockets.

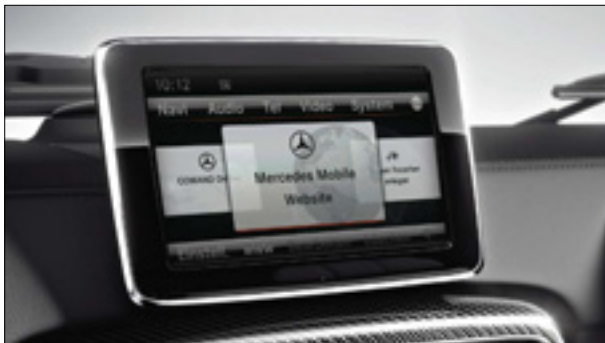

COMAND Online combines in-car entertainment, hard disk drive navigation and a high-resolution 7-inch central display



With 12 speakers, 450 watts and Logic 7® processing, the Harman Kardon® audio system delivers cabin-filling surround sound



The rear seat entertainment system's twin displays are attached to the backs of the front seat head restraints





## Parking aids

The G-Class offers features that make for more stress-free manoeuvring.

**Reversing camera** (standard). Activated automatically as soon as the driver engages reverse, this wide-angle camera captures the area immediately behind the car and displays the image on the COMAND Online display, making for safer and easier low-speed manoeuvres.

**Parktronic with Parking Guidance** (standard). Parktronic uses the sonar principle to help you avoid low-speed knocks during parking manoeuvres. It sends out ultrasound signals that reflect off other objects and are picked up by sensors in the front and rear bumpers. The system then processes this information and calculates the size of the gap, enabling it to alert you via acoustic and visual warnings as you approach the vehicle or object.



The reversing camera uses the central display to show you what's immediately behind the car



Parktronic's LEDs indicate the distance from other objects when manoeuvring







> View price list



> View offers



Book a > test drive > AMG test drive



> Mercedes-Benz Magazine

## Standard equipment | Selection



Twin bottle holder in rear



Sequentially lockable differentials



Reversing camera



Privacy glass and electrically adjustable front seats with memory function



Automatic climate control



Harman Kardon® Logic 7® surround sound system

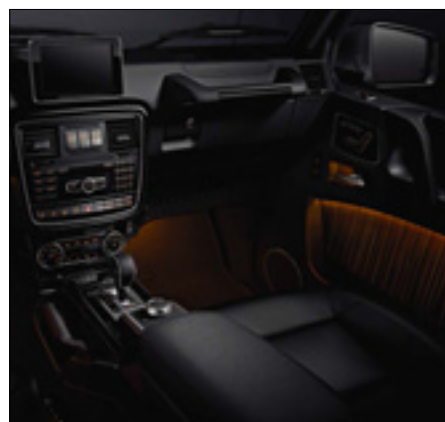

Ambient interior lighting



Tow bar





> View price list



> View offers



Book a > test drive > AMG test drive



> Mercedes-Benz Magazine

## Optional extras | Selection



High gloss Brown Burr Walnut wood trim



*designo* Champagne White Piano Lacquer trim



*designo* Light Brown Poplar wood trim (satin finish)



AMG carbon fibre interior trim



Seat Comfort Package (optional; standard on G 63 AMG 4MATIC)



Electric tilting/sliding sunroof (standard on G 63 AMG 4MATIC)



20" AMG alloy wheels in 5-spoke design, painted matt black (optional on G 63 AMG 4MATIC only)



Heated steering wheel (optional on G 350 BlueTEC 4MATIC only)





> View price list



> View offers



Book a > test drive > AMG test drive



> Mercedes-Benz Magazine

## Sports Styling Package

The optional Sports Styling Package contains eye-catching chrome elements which add to the exclusivity of your G-Class.

With its chrome-trimmed three-bar grille, the optional Sports Styling Package brings an extra touch of exclusivity to the G-Class exterior (standard on G 63 AMG 4MATIC, with model-specific two-bar grille). The enhancements also include stainless steel running boards and a stainless steel spare wheel cover with 3D three-pointed star, chrome surrounds for the front door speakers and

wood-trimmed seat adjustment consoles, plus a chromed load sill guard with 'Mercedes-Benz' or 'AMG' lettering according to the chosen model.



Radiator grille with chrome inserts



Stainless steel spare wheel cover with three-dimensional star



AMG flared wheel arches and running boards left and right





## Entertainment Package

The rear seat entertainment system offers all rear passengers entertainment of a high technical standard.



During the journey, rear passengers can watch DVDs by means of the DVD players integrated in the displays or use external entertainment devices such as game consoles. Each screen works independently from the other, or content can be played simultaneously.

The TV tuner<sup>1</sup> makes it possible to receive digital terrestrial channels around the world, plus Teletext access, a choice of up to 30 channels, audio playback through speaker and playback through front COMAND screen up to approx. 4 mph.

The rear displays include DVD players, and can accommodate external entertainment devices

<sup>1</sup>TV tuner plays through COMAND Online screen only





## Driving Assistance Package

Blind Spot Assist and Distronic Plus form part of this innovative safety-enhancing package.

The Driving Assistance Package consists of two intelligent features that prove particularly useful when driving on motorways: Blind Spot Assist utilises short-range radar sensors to monitor the area not visible to the driver. If the system detects a vehicle in the blind spot, a red triangle lights up in the respective exterior mirror to alert the driver, reducing the risk of causing a collision.

Distronic Plus helps the driver automatically maintain a safe distance from the vehicle ahead. The system extends the functionality of the conventional cruise control with variable speed limiter and when necessary activates the brakes and returns it to its preset speed.



Blind Spot Assist helps you to avoid dangerous lane changes



Distronic Plus radar-assisted cruise control automatically maintains a set distance from the vehicle in front





> View price list



> View offers



Book a > test drive > AMG test drive



> Mercedes-Benz Magazine

## Exclusive Package

The Exclusive Package more than lives up to its name.



The optional Exclusive Package is an ideal starting point for those looking to individualise their G-Class. It includes ventilated multi-contour front seats (part of the included Seat Comfort Package). Illuminated door sill panels light the way in and out of the cabin, while a *designo* Black Dinamica roof lining further adds to the air of quality.

Multi-contour seats can help you to stay comfortable and alert on long journeys





> View price list



> View offers



Book a > test drive > AMG test drive



> Mercedes-Benz Magazine

## Winter Package

Smart thinking to make driving in cold winter conditions more comfortable.



The heated windscreen can be activated at the touch of a button

Wouldn't it be great if your car were all warm and cosy right at start of your journey on a cold winter day? That's what the Winter Package is designed to do. It comes with a fuel-fired heater that operates independently of the engine. It can be set to heat or ventilate the interior by remote control or by programming the departure time. A heated windscreen function enables the windscreen to be easily defrosted. You can also set the windscreen and side windows to be demisted, at the touch of a button.



The auxiliary heater can be programmed to start before you start the journey





> View price list



> View offers



Book a > test drive > AMG test drive



> Mercedes-Benz Magazine

## *designo* Exclusive Package

Luxurious leather, exquisite design – reserved exclusively for the G 63 AMG 4MATIC.



*designo* is the byword for exclusivity in the G 63 AMG 4MATIC: with two-tone *designo* leather upholstery all round, the *designo* Exclusive Package makes this unique off-roader feel even more extravagant. It offers a choice of six different colour combinations and features a distinctive diamond-pattern leather for the door panels and seat centre panels, while the dashboard also boasts sumptuous *designo* leather. The package is exclusive to the G 63 AMG 4MATIC.







## Upholstery and trim



The Black interior scheme features leather upholstery and a grey roof lining. Anthracite Alcantara® roof lining is standard on the G 63 AMG 4MATIC and optional on the G 350 BlueTEC 4MATIC. The G 350 BlueTEC 4MATIC has a Black nappa leather steering wheel and Anthracite Poplar wood trim as standard, while a wood- and leather-trimmed steering wheel can be specified in conjunction with the optional Brown Burr Walnut wood interior trim. Also available are a variety of *designo* interior trim options, as well as carbon fibre trim by AMG.

### Black

SP3 Leather<sup>1</sup>

### Trim

VF7 Anthracite Poplar wood<sup>1</sup>

V56 Brown Burr Walnut wood (high gloss)<sup>2</sup>

ZG2 *designo* Black Piano Lacquer<sup>3</sup>

ZG8 *designo* Champagne White Piano Lacquer<sup>2</sup>

ZT0 *designo* Light Brown Poplar wood (satin finish)<sup>2</sup>

ZG6 AMG carbon fibre<sup>4</sup>

<sup>1</sup>Standard on G 350 BlueTEC 4MATIC, not available on G 63 AMG 4MATIC

<sup>2</sup>Optional on G 350 BlueTEC 4MATIC, no-cost option on G 63 AMG 4MATIC

<sup>3</sup>Optional on G 350 BlueTEC 4MATIC, standard on G 63 AMG 4MATIC <sup>4</sup>Optional

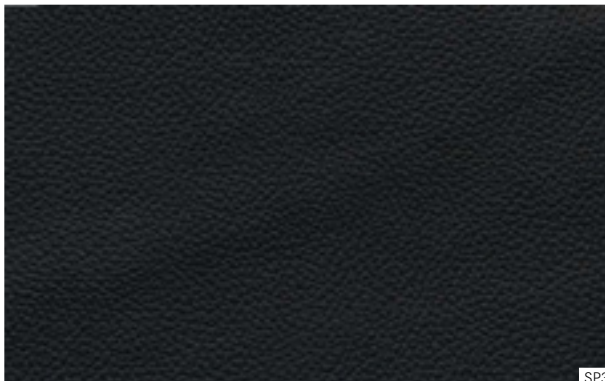

SP3



VF7



ZG8



V56



ZT0



ZG2



ZG6





> View price list



> View offers



Book a > test drive > AMG test drive



> Mercedes-Benz Magazine



The Alpaca Grey interior scheme features Alpaca Grey leather upholstery. The steering wheel, dashboard and carpets come in contrasting black. An Anthracite Alcantara® roof lining is standard on the G 63 AMG 4MATIC and optional on the G 350 BlueTEC 4MATIC. The G 350 BlueTEC 4MATIC has a Black nappa leather-trimmed steering wheel and Anthracite poplar wood trim as standard, while a wood- and leather-trimmed steering wheel can be specified in conjunction with the optional Brown Burr Walnut wood interior trim. A variety of *designo* interior trim options are also available, as well as carbon fibre trim by AMG.

**Alpaca Grey**

SP4 Leather<sup>1</sup>

**Trim**

VF7 Anthracite Poplar wood<sup>1</sup>

V56 Brown Burr Walnut wood (high gloss)<sup>2</sup>

ZG2 *designo* Black Piano Lacquer<sup>3</sup>

ZG8 *designo* Champagne White Piano Lacquer<sup>2</sup>

ZT0 *designo* Light Brown Poplar wood (satin finish)<sup>2</sup>

ZG6 AMG carbon fibre<sup>4</sup>

<sup>1</sup>Standard on G 350 BlueTEC 4MATIC, not available on G 63 AMG 4MATIC

<sup>2</sup>Optional on G 350 BlueTEC 4MATIC, no-cost option on G 63 AMG 4MATIC

<sup>3</sup>Optional on G 350 BlueTEC 4MATIC, standard on G 63 AMG 4MATIC <sup>4</sup>Optional

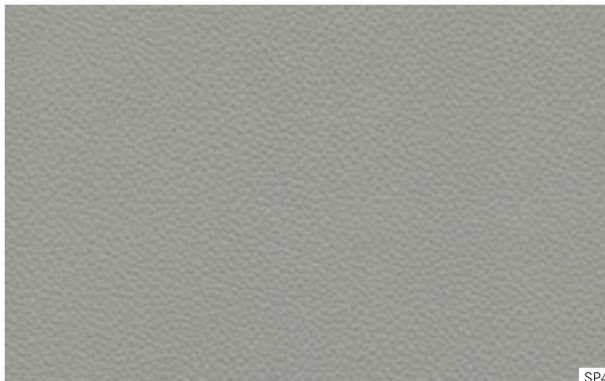

SP4



VF7



ZG8

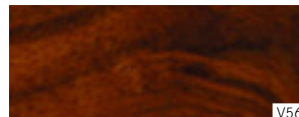

V56



ZT0



ZG2

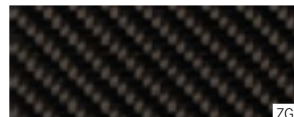

ZG6





> View price list



> View offers



Book a > test drive > AMG test drive



> Mercedes-Benz Magazine



The Chestnut interior scheme features Chestnut leather upholstery and a grey roof lining, with an Anthracite Alcantara® roof lining available as an option (standard on the G 63 AMG 4MATIC). The steering wheel, dashboard and carpets come in contrasting black. The G 350 BlueTEC 4MATIC has a Black nappa leather-trimmed steering wheel and Anthracite Poplar wood trim as standard, while a wood- and leather-trimmed steering wheel can be specified in conjunction with the optional Brown Burr Walnut wood interior trim. A variety of *designo* interior trim options are also available, as well as carbon fibre trim by AMG.

**Chestnut**

SP5 Leather<sup>1</sup>

**Trim**

VF7 Anthracite Poplar wood<sup>1</sup>

V56 Brown Burr Walnut wood (high gloss)<sup>2</sup>

ZG2 *designo* Black Piano Lacquer<sup>3</sup>

ZG8 *designo* Champagne White Piano Lacquer<sup>2</sup>

ZT0 *designo* Light Brown Poplar wood (satin finish)<sup>2</sup>

ZG6 AMG carbon fibre<sup>4</sup>

<sup>1</sup>Standard on G 350 BlueTEC 4MATIC, not available on G 63 AMG 4MATIC

<sup>2</sup>Optional on G 350 BlueTEC 4MATIC, no-cost option on G 63 AMG 4MATIC

<sup>3</sup>Optional on G 350 BlueTEC 4MATIC, standard on G 63 AMG 4MATIC <sup>4</sup>Optional

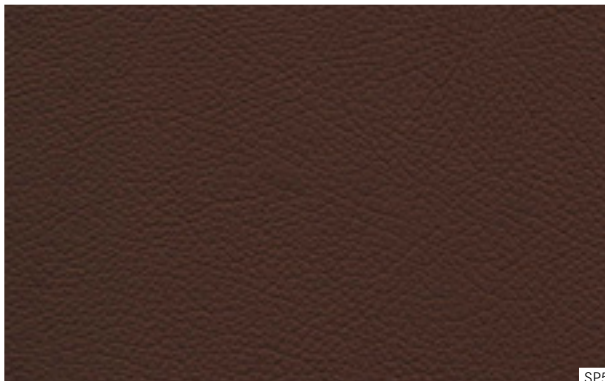

SP5



VF7



V56



ZG2



ZG8



ZT0

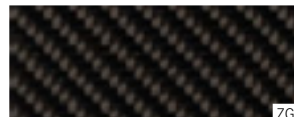

ZG6





## *designo*

Individuality at its most alluring: *designo* offers a host of ways to make your G-Class even more distinctive. → [www.mercedes-benz.co.uk/designo](http://www.mercedes-benz.co.uk/designo)

Create a G-Class that's one of a kind – with exclusive *designo* paint finishes and sumptuous interior appointments hand-crafted from the finest materials. For the exterior, there's a choice of three *designo* metallic finishes (*designo* Mocha Black, Graphite and Platinum Black), three *designo* Mystic finishes (*designo* Mystic Blue, Mystic Red and Mystic Brown) and two *designo* Magno matt finishes (*designo* Magno Platinum and Magno Night Black).

Inside, hand-stitched *designo* leather upholstery brings an unmistakable air of luxury to the G-Class cabin. There are eight single-tone upholsteries to choose from (*designo* Porcelain, Marron, Classic Red, Black, Light Brown, Sand, Mystic Red and Titan Pearl). Each comes with door panels

in ruffled leather, velour floor mats edged in *designo* leather and an Anthracite Alcantara® roof lining. Single-tone *designo* leather upholstery comes as standard on the G 63 AMG 4MATIC and is available as an option on the G 350 BlueTEC 4MATIC. An eye-catching *designo* wood- and leather-trimmed steering wheel is also available as a separate option (standard on the G 63 AMG 4MATIC).

For an even more luxurious G 63 AMG 4MATIC, there's the optional *designo* Exclusive Package (only available in conjunction with the optional Seat Comfort Package). It gives you a choice of six two-tone *designo* leather upholsteries and also includes a *designo* leather-covered dashboard.





> View price list



> View offers



Book a > test drive > AMG test drive



> Mercedes-Benz Magazine

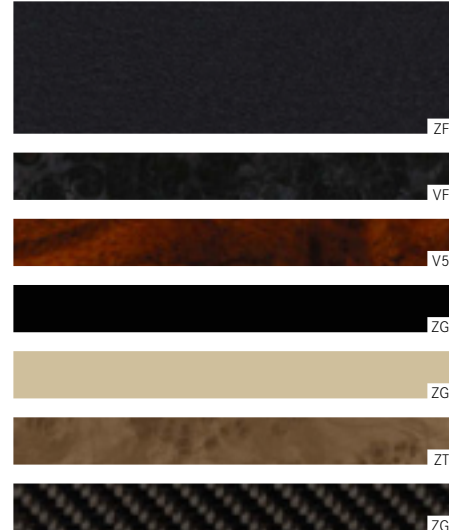

**designo Black leather** (optional)

ZF7 *designo* leather<sup>1</sup>

**Trim**

VF7 Anthracite Poplar wood<sup>2</sup>

V56 Brown Burr Walnut wood (high gloss)<sup>3</sup>

ZG2 *designo* Black Piano Lacquer<sup>1</sup>

ZG8 *designo* Champagne White Piano Lacquer<sup>3</sup>

ZT0 *designo* Light Brown Poplar wood (satin finish)<sup>3</sup>

ZG6 AMG carbon fibre<sup>4</sup>

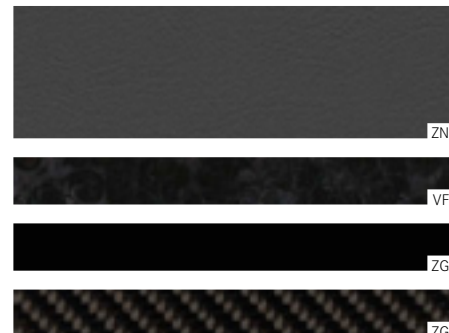

**designo Titan Pearl leather** (optional)

ZN9 *designo* leather<sup>1</sup>

**Trim**

VF7 Anthracite Poplar wood<sup>2</sup>

ZG2 *designo* Black Piano Lacquer<sup>1</sup>

ZG6 AMG carbon fibre<sup>4</sup>

<sup>1</sup>Optional on G 350 BlueTEC 4MATIC, no-cost option on G 63 AMG 4MATIC <sup>2</sup>Standard on G 350 BlueTEC 4MATIC, not available on G 63 AMG 4MATIC

<sup>3</sup>Optional on G 350 BlueTEC 4MATIC, no-cost option on G 63 AMG 4MATIC

<sup>4</sup>Optional





> View price list



> View offers



Book a > test drive > AMG test drive



> Mercedes-Benz Magazine

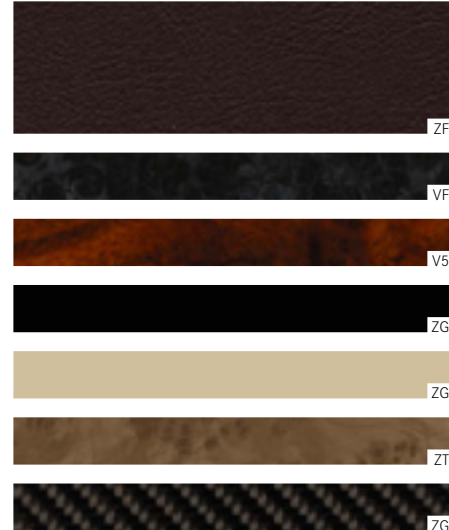

**designo Marron leather** (optional)

ZF4 *designo* leather<sup>1,2</sup>

**Trim**

VF7 Anthracite Poplar wood<sup>3</sup>

V56 Brown Burr Walnut wood (high gloss)<sup>1</sup>

ZG2 *designo* Black Piano Lacquer<sup>4</sup>

ZG8 *designo* Champagne White Piano Lacquer<sup>1</sup>

ZT0 *designo* Light Brown Poplar wood (satin finish)<sup>1</sup>

ZG6 AMG carbon fibre<sup>5</sup>

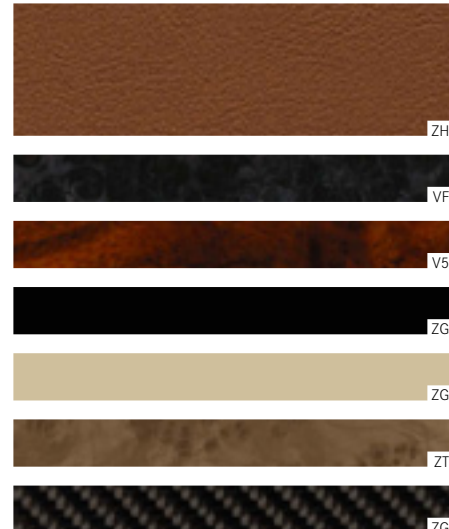

**designo Light Brown leather** (optional)

ZH2 *designo* leather<sup>1</sup>

**Trim**

VF7 Anthracite Poplar wood<sup>3</sup>

V56 Brown Burr Walnut wood (high gloss)<sup>1</sup>

ZG2 *designo* Black Piano Lacquer<sup>4</sup>

ZG8 *designo* Champagne White Piano Lacquer<sup>1</sup>

ZT0 *designo* Light Brown Poplar wood (satin finish)<sup>1</sup>

ZG6 AMG carbon fibre<sup>5</sup>

<sup>1</sup>Optional on G 350 BlueTEC 4MATIC, no-cost option on G 63 AMG 4MATIC <sup>2</sup>Not available in conjunction with *designo* Exclusive Package (PA6) <sup>3</sup>Standard on G 350 BlueTEC 4MATIC, not available for G 63 AMG 4MATIC <sup>4</sup>Optional, standard on G 63 AMG 4MATIC <sup>5</sup>Optional





> View price list



> View offers



Book a > test drive > AMG test drive



> Mercedes-Benz Magazine

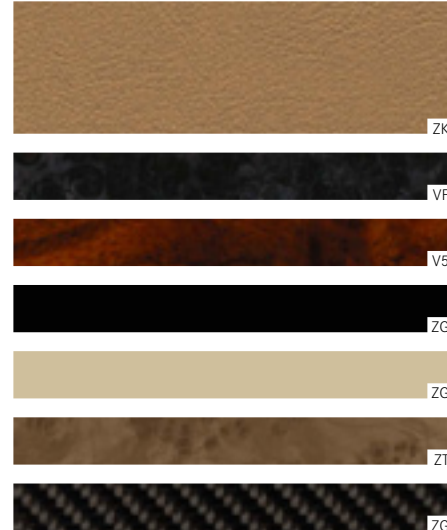

**designo Sand leather** (optional)

ZK6 *designo* leather<sup>1</sup>

**Trim**

VF7 Anthracite Poplar wood<sup>2</sup>

V56 Brown Burr Walnut wood (high gloss)<sup>1</sup>

ZG2 *designo* Black Piano Lacquer<sup>3</sup>

ZG8 *designo* Champagne White Piano Lacquer<sup>1</sup>

ZT0 *designo* Light Brown Poplar wood (satin finish)<sup>1</sup>

ZG6 AMG carbon fibre<sup>4</sup>

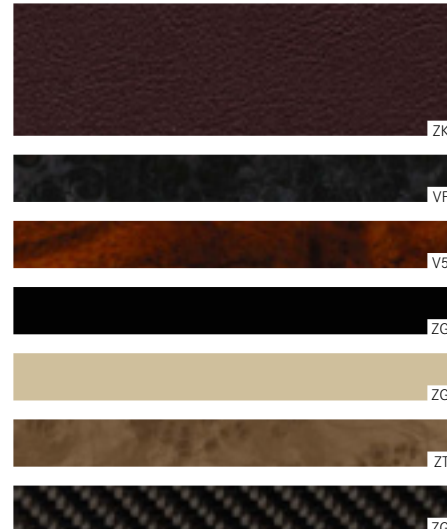

**designo Mystic Red leather** (optional)

ZK8 *designo* leather<sup>1,5</sup>

**Trim**

VF7 Anthracite Poplar wood<sup>2</sup>

V56 Brown Burr Walnut wood (high gloss)<sup>1</sup>

ZG2 *designo* Black Piano Lacquer<sup>3</sup>

ZG8 *designo* Champagne White Piano Lacquer<sup>1</sup>

ZT0 *designo* Light Brown Poplar wood (satin finish)<sup>1</sup>

ZG6 AMG carbon fibre<sup>4</sup>

<sup>1</sup>Optional on G 350 BlueTEC 4MATIC, no-cost option on G 63 AMG 4MATIC <sup>2</sup>Standard on G 350 BlueTEC 4MATIC, not available for G 63 AMG 4MATIC <sup>3</sup>Optional, standard on G 63 AMG 4MATIC <sup>4</sup>Optional <sup>5</sup>Not available in conjunction with *designo* Exclusive Package (PA6)





> View price list



> View offers



Book a > test drive > AMG test drive



> Mercedes-Benz Magazine

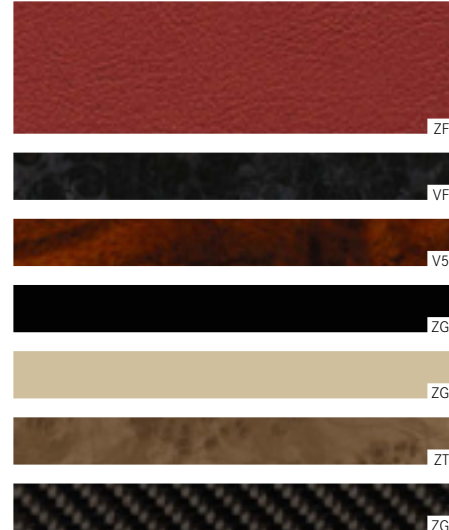

**designo Classic Red leather** (optional)

ZF5 *designo* leather<sup>1</sup>

**Trim**

VF7 Anthracite Poplar wood<sup>2</sup>

V56 Brown Burr Walnut wood (high gloss)<sup>3</sup>

ZG2 *designo* Black Piano Lacquer<sup>3</sup>

ZG8 *designo* Champagne White Piano Lacquer<sup>1</sup>

ZT0 *designo* Light Brown Poplar wood (satin finish)<sup>1</sup>

ZG6 AMG carbon fibre<sup>4</sup>

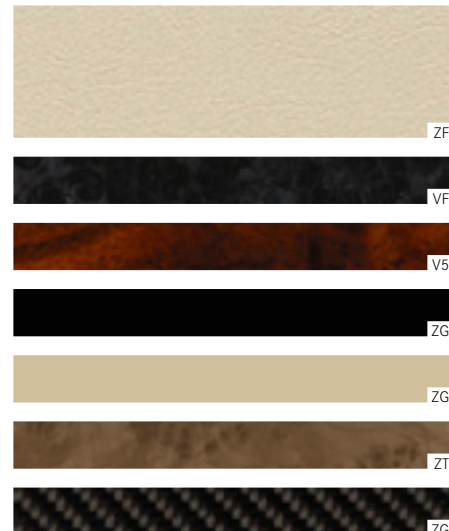

**designo Porcelain leather** (optional)

ZF3 *designo* leather<sup>1</sup>

**Trim**

VF7 Anthracite Poplar wood<sup>2</sup>

V56 Brown Burr Walnut wood (high gloss)<sup>3</sup>

ZG2 *designo* Black Piano Lacquer<sup>3</sup>

ZG8 *designo* Champagne White Piano Lacquer<sup>1</sup>

ZT0 *designo* Light Brown Poplar wood (satin finish)<sup>1</sup>

ZG6 AMG carbon fibre<sup>4</sup>

<sup>1</sup>Optional on G 350 BlueTEC 4MATIC, no-cost option on G 63 AMG 4MATIC <sup>2</sup>Standard on G 350 BlueTEC 4MATIC, not available for G 63 AMG 4MATIC <sup>3</sup>Optional, standard on G 63 AMG 4MATIC <sup>4</sup>Optional







> View price list



> View offers



Book a > test drive > AMG test drive



> Mercedes-Benz Magazine

## Alloy wheels



18" 5-twin-spoke alloy wheels with 265/60 R 18 tyres (standard on G 350 BlueTEC 4MATIC, code RM9)



20" AMG 5-twin-spoke alloy wheels with burnished Titanium Grey high sheen finish and 275/50 R 20 tyres (standard on G 63 AMG 4MATIC, code R10)



18" 5-twin-spoke alloy wheels with Titanium Grey finish and 265/60 R 18 tyres (only available as part of the optional Sports Styling Package, code RM9)



20" AMG 5-spoke alloy wheels painted matt black high sheen finish and 275/50 R 20 tyres (optional on G 63 AMG 4MATIC, code R11)





## Services

**Test drive.** You've seen the pictures, you've read the facts. Now all that's missing is to experience your dream Mercedes in the flesh. Which is why we invite you to take it for a spin. See it with your own eyes. Rev up the engine, and feel how your chosen Mercedes hugs the road. Relax in style or play with a whole host of exciting onboard technology. Contact your Mercedes-Benz Retailer for a test drive, or simply go online and visit [www.mercedes-benz.co.uk/testdrive](http://www.mercedes-benz.co.uk/testdrive). We can't wait to see you in the driving seat.

**Mercedes-Benz Finance.** At Mercedes-Benz Finance, our single-minded aim is to provide optimum financial solutions for all those who share the Mercedes-Benz philosophy of absolute commitment to quality. Whether you are a private customer or a business user, our finance and leasing packages can be tailored to meet your individual needs. For further information on Mercedes-Benz Finance, please contact your local Mercedes-Benz Retailer.



**Mercedes-Benz Insurance** offers a fully comprehensive 5-star Motor Insurance policy, rated by Defaqto, a leading UK independent financial research company. Our policy is specifically designed to provide the cover you would expect from Mercedes-Benz. For a quotation, please call 0345 600 2180.<sup>1</sup>

**Interactive Owner's Manual.** The website also offers an interactive tour, enabling you to take a closer look at your desired model. This simulation is the ideal way to acquaint yourself with your dream car. You can view key functions in detail, gain an insight into the car's inner workings or look at the benefits of each model. For further details, visit [www.mercedes-benz.co.uk/gclassmanual](http://www.mercedes-benz.co.uk/gclassmanual)

<sup>1</sup>Mercedes-Benz Motor Insurance is underwritten by Aviva Insurance Limited. For joint protection, calls may be recorded and/or monitored. All calls are charged at local rate. We may decline to quote in some circumstances





**Roadside Assistance.** Rest assured that should you ever need help, Mercedes-Benz Roadside Assistance is there for you. In the unlikely event of a technical breakdown<sup>2</sup> you can rely on the Mercedes-Benz Roadside Assistance Team – anywhere in Europe. Simply phone our Customer Assistance Centre on +44 (0)20 7975 7077,<sup>3</sup> where our specialists will organise assistance for you. Mercedes-Benz will also assist you in the event of a minor mishap preventing you from driving your vehicle.<sup>4</sup> Whether you lose your key, run out of fuel, or your vehicle is damaged due to an accident or vandalism,<sup>4</sup> Mercedes-Benz ensures that you still reach your destination. Often, the problem can be rectified on the spot, but if this is not possible, we will naturally ensure that your vehicle is taken to the nearest Mercedes-Benz Retailer to get you back on the road as quickly as possible.

<sup>2</sup>Cover is initially valid for your vehicle for four years from the date of first registration. This can be extended from the fifth year, up to a maximum of 30 years, on completion of each scheduled maintenance service, providing that this service is carried out by a Mercedes-Benz Retailer, and recommended items are completed

<sup>3</sup>If your mobile phone provider charges for Freephone numbers please call 020 7975 7077

<sup>4</sup>Minor mishap cover is provided at the absolute discretion of Mercedes-Benz

**Service Care.** To keep a tight grip on costs, Mercedes-Benz offers service plans to cover the costs of an annual service, for two, three and four years. Plans can be paid monthly with interest-free instalments or alternatively, if you pay upfront, should you sell your vehicle any remaining services will be transferred to the new owner. All routine maintenance and additional items are covered. To find out more, please contact your local Retailer or visit [www.mercedes-benz.co.uk/servicecare](http://www.mercedes-benz.co.uk/servicecare)

**Mercedes-Benz World at Brooklands.** Put our latest vehicles to the test at Mercedes-Benz World. Book an AMG Driving Experience on our handling circuits or tackle the deep water crossings and axle-twisting obstacles on our 10 acre off-road course. Under 16s can drive on the historic Brooklands circuit, while three to five year olds can become Little Learners on our indoor driving circuit. Discover automotive legends like the original 300 SL Gullwing, Formula 1<sup>®</sup> cars and the UK's largest collection of Mercedes-Benz and AMG models under one roof. Relax and refuel in Café 1886, or enjoy the delicious menu and elegant surroundings of the Gullwing Bistro. With three floors of interactive attractions and exhibitions, free entry and free parking every day, the whole family will enjoy an adrenaline-fuelled day out at Mercedes-Benz World. To book a Driving Experience call 0370 400 4000 or for more information visit [www.mercedes-benzworld.co.uk](http://www.mercedes-benzworld.co.uk)





> View price list



> View offers



Book a > test drive > AMG test drive



> Mercedes-Benz Magazine

# Dimensions

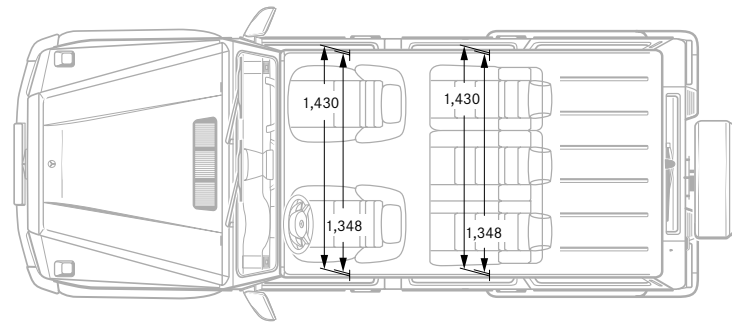
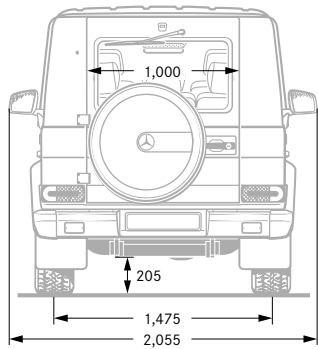
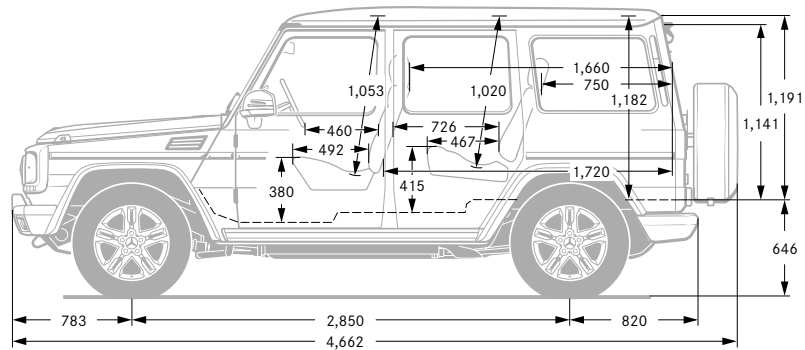
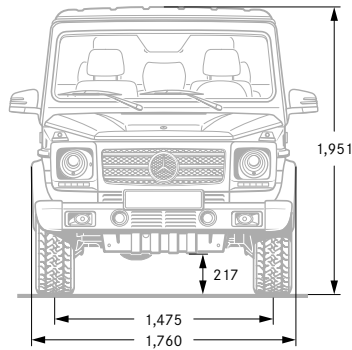

All measurements in millimetres. The dimensions shown are mean values and apply to standard-specification, unladen vehicles





## Technical specifications

	Diesel engine	AMG petrol engine
	G 350 BlueTEC 4MATIC	G 63 AMG 4MATIC
Arrangement/cylinders/valves	V/6/24	V/8/32
Capacity – cc	2,987	5,461
Rated output <sup>1</sup> – hp (kW) at rpm	211 (155)/3,400	544 (400)/5,500
Rated torque <sup>1</sup> – Nm at rpm	540/1,600–2,400	760/2,000–5,000
Compression ratio	17.7:1	10.0:1
Acceleration 0–62 mph – sec	9.1	5.4
Top speed, approx. – mph	108	130 <sup>4</sup>
Tyre size	265/60 R 18	275/50 R 20
Fuel consumption <sup>2</sup> – mpg		
Urban	20.8	16.4
Extra-urban	28.8	23.9
Combined	25.2	20.5
CO <sub>2</sub> emissions, combined <sup>2</sup> – g/km	295	322
EU emissions standard	EU5	EU5
Fuel tank capacity/of which reserve – l	96/14	96/14
Turning circle – m	13.6	13.6
Kerb weight <sup>3</sup> /Perm. Gross Vehicle Weight – kg	2,570/3,200	2,550/3,200
Towing capacity, braked/unbraked – kg	3,500/750	3,500/750

<sup>1</sup>Figures in accordance with Directive 80/1269/EEC in the currently applicable version <sup>2</sup>The figures shown were obtained in accordance with the prescribed measuring process (Directive 80/1268/EEC in the currently applicable version).

<sup>3</sup>Figures according to Directive 92/21/EC, version 95/48/EC (kerb weight with fuel tank 90% full, driver, 68 kg, and luggage, 7 kg) for standard-specification vehicles. Optional extras and accessories will generally increase this figure and reduce the payload capacity accordingly. The figures are not based on an individual model and do not constitute part of the product offer; they are provided solely for purposes of comparison between different vehicle models <sup>4</sup>Electrically limited





# Paint finishes

## Non-metallic paints (no-cost option)



040 Black



149 Polar White

## Metallic paints (standard)



183 Magnetite Black



197 Obsidian Black



300 Periclase Green



359 Tanzanite Blue



541 Thulite Red



755 Tenorite Grey



775 Iridium Silver



792 Palladium Silver



796 Citrine Brown



963 Indium Grey



988 Diamond Silver

## designo paints (optional)



033 *designo* Mocha Black



041 *designo* Graphite



046 *designo* Platinum Black



032 *designo* Mystic Blue



037 *designo* Mystic Red



052 *designo* Mystic Brown



051 *designo* Magno Platinum



056 *designo* Magno Night Black

A wider range of *designo* paint finishes is available from your Mercedes-Benz Retailer





> View price list



> View offers



Book a > test drive > AMG test drive



> Mercedes-Benz Magazine

**Take-back of end-of-life vehicles. Coming full circle.** At the end of its long life, you can return your G-Class to us for environment-friendly disposal in accordance with the EC End-of-Life Vehicle Directive.<sup>1</sup> But that day lies a long way off.

<sup>1</sup>Applies in accordance with national regulations to vehicles up to 3.5 tonnes permissible gross weight. The G-Class has met the statutory regulations governing the suitability of the vehicle's design for reuse and recycling for a number of years now. A network of vehicle take-back depots and dismantlers has been established which will process your vehicle in an environment-friendly manner. The ways in which both vehicles and parts can be recovered are subject to ongoing development and improvement. Consequently, the G-Class will be able to comply with any future increases in the recycling quota within the stipulated time limits. Further information is available at [www.mercedes-benz.co.uk](http://www.mercedes-benz.co.uk) or by calling 0333 222 0500.

**Please note:** this online version of the printed brochure may contain abridged copy or other content changes. The manufacturer reserves the right to make changes to the design, form, colour and specification during the delivery period, provided these changes, while taking into account the interests of the vendor, can be deemed reasonable with respect to the purchaser. Where the vendor or the manufacturer uses symbols or numbers to describe an order or the subject of an order, no rights may be derived solely from these. The illustrations may show accessories and items of optional equipment which are not part of standard specification. Colours may differ slightly from those shown. This brochure provides a general indication of the range of models, features, optional extras and/or colours available in various countries. Some of the models, features, optional extras and/or colours shown may not be available in your country or may only be available in a different specification. Additionally some models, features, optional extras and/or colours may only be available in combination with others. For current and more specific information in relation to the range of models, features, optional extras and/or colours available in your country, and their pricing, you should contact your nearest authorised Mercedes-Benz Retailer. E&OE. [www.mercedes-benz.co.uk](http://www.mercedes-benz.co.uk)

Daimler AG, Mercedesstr. 137, 70327 Stuttgart BC/MC 6701 · 0913 · 88-02/0614

Follow us on the following social media channels:



<https://www.facebook.com/MercedesBenzUk>



<https://twitter.com/mercedesbenz>



<https://www.youtube.com/user/mercedesbenz>



<https://instagram.com/mercedesbenz>

