



> View price list



> View offers



> SOUND WITH POWER



> Mercedes-Benz Magazine

# GLA-Class



Mercedes-Benz







> View price list



> View offers



> SOUND WITH POWER



> Mercedes-Benz Magazine

## The new GLA. Freedom is contagious

The new GLA can't wait to show you what it's made of: while the exterior design proves intensely dynamic, choosing our 4MATIC all-wheel drive system with variable torque distribution promises a powerful performance – on or off the road. Combine that with outstanding practicality, and the new Mercedes-Benz GLA is ready to take you where no one has ever gone before. Here's to more freedom to explore.

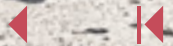





> View price list



> View offers



> SOUND WITH POWER



> Mercedes-Benz Magazine

## Close-up or far, far away: breathtaking views from every angle

High stance, broad shoulders, low roofline – excitement all the way to the muscular rear section with LED rear tail lights and the twin-pipe exhaust system with chrome tailpipe tips. There's a lot to marvel at. And that's before you've even taken your seat in the equally stylish cockpit.

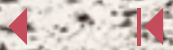





> View price list



> View offers



> SOUND WITH POWER



> Mercedes-Benz Magazine



Inside, there is a whole new world of refinement. Depending on your choice of model line, you'll enjoy standard comfort seats, as seen here on the GLA SE, or sports seats on the GLA AMG Line. Artico leather<sup>1</sup> upholstery is matched with a wave-design silver trim on the SE, while the AMG Line features Artico leather<sup>1</sup>/Dinamica microfibre with contrast red stitching. The Audio 20 radio system comes as standard, along with Media Interface, Bluetooth<sup>®</sup> and USB port to play music from external devices. You can also choose the optionally available COMAND Online to connect to the Internet, use HDD map navigation and access various apps. What's more, the optional Drive Kit Plus allows you to use the key functions of your iPhone<sup>®</sup> while on the move. And if you feel like getting closer to the elements, choose the optional panoramic sliding glass sunroof.

<sup>1</sup>Man-made leather

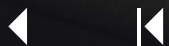





> View price list



> View offers



> SOUND WITH POWER



> Mercedes-Benz Magazine



## Up, up and away

Choice means freedom. Which is why we offer two distinctive model lines and many other optional details for the new GLA – including this stunning Mountain Grey metallic paint. There is also a wide range of optional packages to add individual style or to maximise comfort and safety on board this unique new compact SUV.







> View price list



> View offers



> SOUND WITH POWER



> Mercedes-Benz Magazine

## The epitome of keen

Eager to explore? Try these for size: one petrol and two diesel engines, designed to balance power with efficiency. Choose 4MATIC all-wheel drive to handle every challenge in all weather conditions through greater traction, driving dynamics and driving stability. It combines get up and go with a truly comfortable ride.

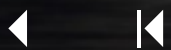



> View price list



> View offers



> SOUND WITH POWER



> Mercedes-Benz Magazine

## Break away from the norm - with 4MATIC technology

For a safer, more controlled drive in all conditions, the GLA is available with 4MATIC technology on both petrol and diesel engines at the touch of a button. The programme increases traction on uneven surfaces; Downhill Speed Regulation helps you master steep descents; and the 4MATIC display on the standard tablet-style colour screen

provides vital data, including gradient, transverse tilt and compass direction. The optional Intelligent Light System even features an off-road light function which adapts beam and light intensity to off-road conditions.







> View price list



> View offers



> SOUND WITH POWER



> Mercedes-Benz Magazine



## Everything except limits

With such a comprehensive range of standard equipment, the new Mercedes-Benz GLA is ready for anything. Of course, a spacious luggage compartment comes as standard on both the GLA SE and AMG Line, alongside innovative technology like the reversing camera. You'll find style and comfort equally in abundance, from the leather three-spoke multi-function steering wheel to the twin cup holders in the armrest of the split-folding rear seats.

The Mercedes-Benz GLA grows with you. It adapts to your needs with a range of option packages. For example, the Premium Plus Package is full of stylish and practical features so you can make the most of your GLA. Take the Easy-Pack tailgate which allows you to open the boot at the touch of a button – or, if you crave fresh air and added brightness, opt for the panoramic glass sunroof with an electrically operated sliding glass section. For greater comfort when parking, Active Park Assist helps you manoeuvre the car. And to ensure your mirrors are protected, they can be folded automatically once the GLA is locked.







> View price list



> View offers



> SOUND WITH POWER



> Mercedes-Benz Magazine

## SE

The SE conquers the road with style, functionality and exhilarating technology – from the chrome-style front apron and 18" alloy wheels to the twin-pipe exhaust system with chrome detail. The interior welcomes you with Artico man-made leather and a wave-design trim in Silver or Anthracite. Along the way you're supported by clever technology: the nappa leather-trimmed multi-function 12-button steering wheel puts all your driving information at your fingertips; Attention Assist alerts you if you lose concentration on long journeys; while the reversing camera helps you keep the GLA scratch-free. There are plenty of useful storage areas throughout – including up to 481 litres of luggage space.



## AMG Line

The AMG Line lends even greater sporty appeal to our striking new compact SUV. Equipped with all the functional and technological assets of the SE, the AMG Line adds AMG bodystyling, 15 mm lowered sports suspension, as well as perforated front brake discs and brake calipers with 'Mercedes-Benz' lettering. The Sports Direct-Steer System ensures an agile driving style, especially as it's paired with a flat-bottom design leather-trimmed multi-function sports steering wheel. Sports seats with integrated head restraints featuring Black Artico man-made leather/Dinamica microfibre upholstery offer ultimate driving support and comfort, and for a firm grip there are brushed stainless steel sports pedals.







> View price list



> View offers



> SOUND WITH POWER



> Mercedes-Benz Magazine

## Night Package

For a truly distinctive look, the GLA AMG Line can be further enhanced with the Night Package. This offers extensive exterior features to complement the AMG Line: a two-louvre high gloss black grille with chrome details, AMG bodystyling on the front, side sill and rear apron in high sheen finish, high gloss black beltline strips and roof rails. Also included are 19" AMG alloy wheels with run-flat tyres.

## Exclusive and AMG Exclusive Packages

Available for the GLA AMG Line only, the Exclusive and AMG Exclusive Packages add even more sophisticated touches. Both offer premium comfort features including leather upholstery with contrast stitching, a stitched Artico man-made leather upper dash, electrically adjustable front seats with memory programme and four-way lumbar support. The AMG Exclusive Package features Lava Black leather with red perforations, red *designo* seat belts, and AMG-branded floor mats.

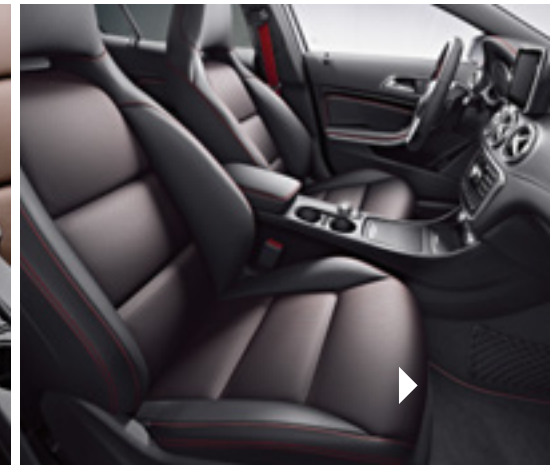
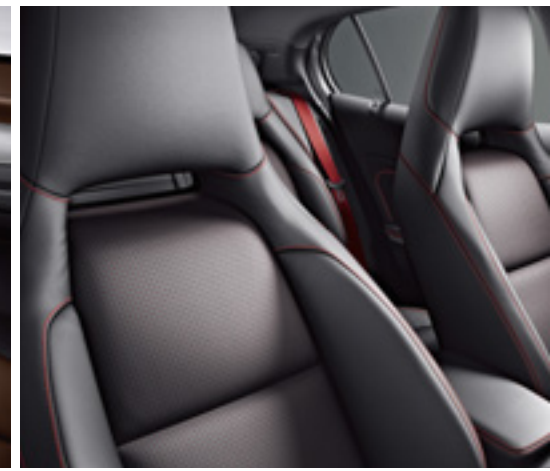





> View price list



> View offers



> SOUND WITH POWER



> Mercedes-Benz Magazine

## Upholstery and trim



### Upholstery

- 101 Artico leather<sup>1</sup> – Black
- 105 Artico leather<sup>1</sup> – Sahara Beige
- 108 Artico leather<sup>1</sup> – Crystal Grey
- 651 Artico leather<sup>1</sup>/Dinamica microfibre – Black
- 801 Leather – Black
- 804 Leather – Hazelnut Brown
- 808 Leather – Crystal Grey
- 811 Leather – Lava Black with red perforations

### Trim

- H50 Wave design – Silver
- H51 Wave design – Anthracite<sup>2</sup>
- H79 Light aluminium with longitudinal grain

<sup>1</sup>Man-made leather <sup>2</sup>Optional







> View price list



> View offers



> SOUND WITH POWER



> Mercedes-Benz Magazine

## Paint finishes

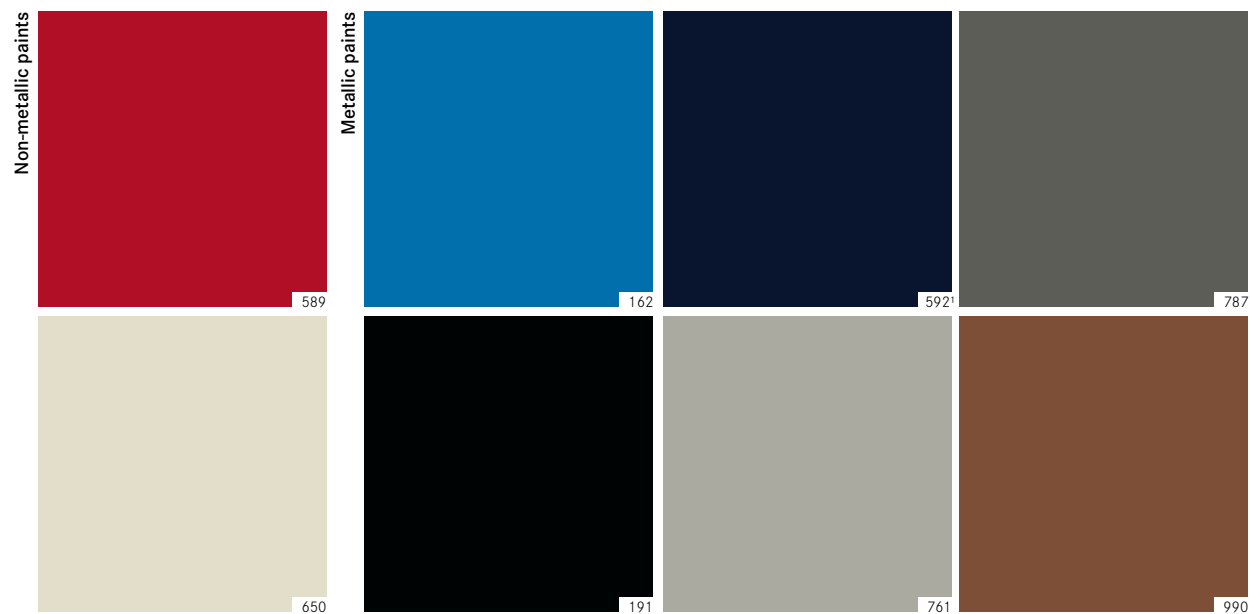

---

### Non-metallic paints (standard)

---

- 589 Jupiter Red
- 650 Cirrus White

---

### Metallic paints (optional)

---

- 162 South Seas Blue
  - 191 Cosmos Black
  - 592 Northern Lights Violet<sup>1</sup>
  - 761 Polar Silver
  - 787 Mountain Grey
  - 990 Orient Bronze
- 

<sup>1</sup>Please check with your Retailer for availability







## Technical data

	DIESEL ENGINES		PETROL ENGINE
	GLA 200 CDI	GLA 220 CDI 4MATIC	GLA 250 4MATIC
Arrangement/cylinders/valves	in-line/4/16	in-line/4/16	in-line/4/16
Total displacement - cc	2,143	2,143	1,991
Rated output <sup>1</sup> - hp (kW) at rpm	136 (100)/3,400-4,000	170 (125)/3,400-4,000	211 (155)/5,500
Rated torque <sup>1</sup> - Nm at rpm	300/1,400-3,000	350/1,400-3,400	350/1,200-4,000
Transmission	6-speed manual [7G-DCT 7-speed automatic]	- [7G-DCT 7-speed automatic]	- [7G-DCT 7-speed automatic]
Acceleration 0-62 mph - sec [auto.]	10.0 [9.9]	- [8.3]	- [7.1]
Top speed, approx. - mph [auto.]	127 [127]	- [134]	- [143]
Tyre size - front, rear	235/50 R 18	235/50 R 18	235/50 R 18
Fuel consumption <sup>2</sup> - mpg [auto.]			
Urban	51.4 [54.3]	- [47.1]	- [34.0]
Extra-urban	72.4 [68.9]	- [62.8]	- [50.4]
Combined	62.8 [62.8]	- [55.4]	- [42.8]
CO <sub>2</sub> emissions, combined <sup>2</sup> - g/km [auto.]	119 [119]	- [132]	- [154]
EU emissions standard <sup>3</sup>	EU6	EU6	EU6
Fuel tank capacity/or which reserve - l	50/6.0	56/6.0	56/6.0
Boot capacity <sup>4</sup> - l	481/1,235	481/1,235	481/1,235
Turning circle - m	11.84	11.84	11.84
Kerb weight <sup>5</sup> - kg [auto.]	1,505 [1,535]	- [1,535]	- [1,505]
Perm. Gross Vehicle Weight - kg [auto.]	2,020 [2,020]	- [2,075]	- [1,990]

<sup>1</sup>Figures according to Directive 80/1269/EC in the currently applicable version <sup>2</sup>The figures shown were obtained in accordance with the prescribed measuring process (Regulation [EC] 715/2007 in the currently applicable version). The figures are not based on an individual model and do not constitute part of the product offer; they are provided solely for purposes of comparison between different vehicle models <sup>3</sup>Specification valid within the European Union only <sup>4</sup>Figures according to Directive 70/156/EEC as amended by 2000/40/EC <sup>5</sup>Figures according to Directive 92/21/EC, version 95/48/EC (kerb weight with fuel tank 90% full, driver, 68 kg, and luggage, 7 kg) for standard-specification vehicles. Optional extras and accessories will generally increase this figure and reduce the payload capacity accordingly <sup>6</sup>The dimensions shown are mean values, and apply to unladen vehicles with standard equipment For more technical data see [www.mercedes-benz.co.uk](http://www.mercedes-benz.co.uk)





> View price list



> View offers



> SOUND WITH POWER



> Mercedes-Benz Magazine

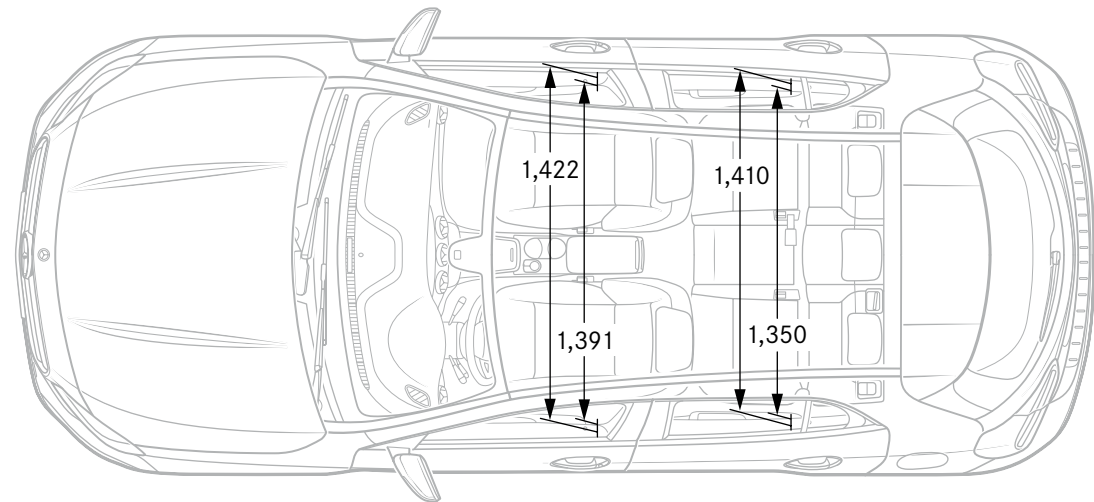
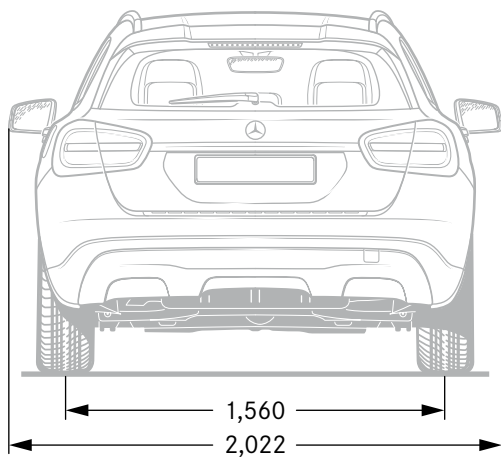
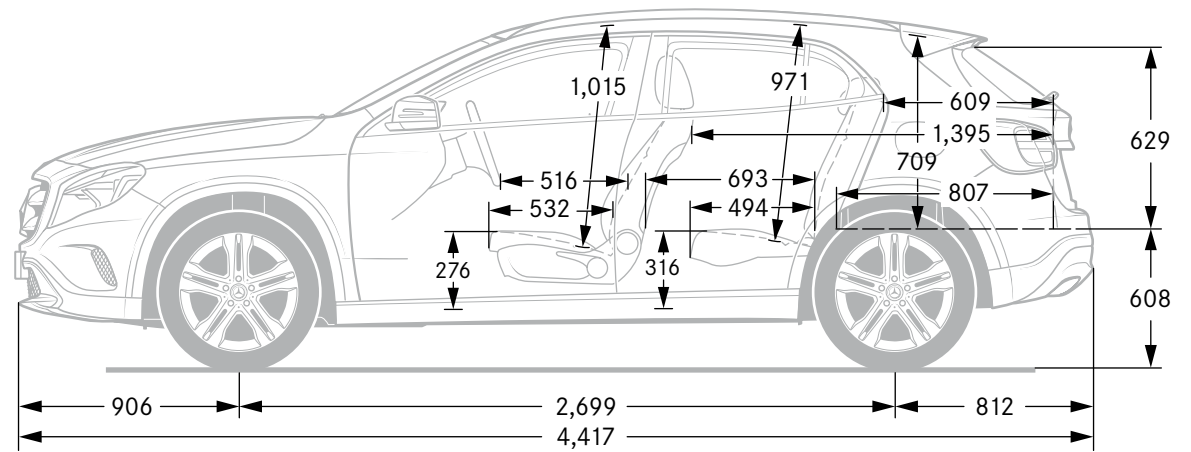
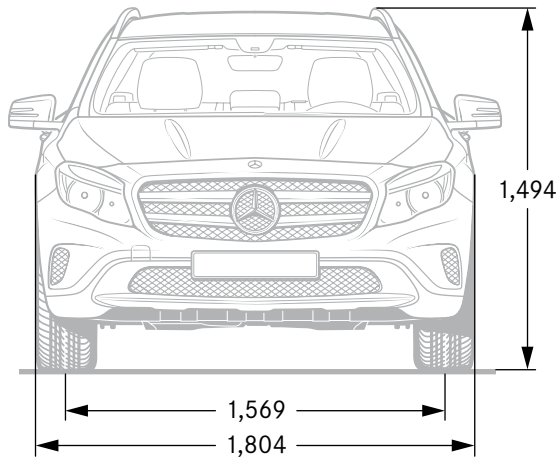





> View price list



> View offers



> SOUND WITH POWER



> Mercedes-Benz Magazine

**Take-back of end-of-life vehicles. Coming full circle.** At the end of its long life, you can return your GLA-Class to us for environment-friendly disposal in accordance with the EC End-of-Life Vehicle Directive.<sup>1</sup> But that day lies a long way off.

<sup>1</sup>Applies in accordance with national regulations to vehicles up to 3.5t permissible gross weight. The GLA-Class has met the statutory regulations governing the suitability of the vehicles' design for reuse and recycling for a number of years now. A network of vehicle take-back depots and dismantlers has been established which will process your vehicle in an environment-friendly manner. The ways in which both vehicles and parts can be recovered are subject to ongoing development and improvement. Consequently, the GLA-Class will be able to comply with any future increases in the recycling quota within the stipulated time limits. For further information, please go to [www.mercedes-benz.co.uk](http://www.mercedes-benz.co.uk) or call 0808 156 6606.

**Please note:** changes may have been made to the products since this brochure went to press (01.08.2013). The manufacturer reserves the right to make changes to the design, form, colour and specification during the delivery period, provided these changes, while taking into account the interests of the vendor, can be deemed reasonable with respect to the purchaser. Where the vendor or the manufacturer uses symbols or numbers to describe an order or the subject of an order, no rights may be derived solely from these. The illustrations may show accessories and items of optional equipment which are not part of standard specification. Colours may differ slightly from those shown in the brochure, owing to the limitations of the printing process. This brochure has been compiled by Daimler AG of Germany and is distributed internationally. It provides a general indication of the range of models, features, optional extras and/or colours available in various countries. Some of the models, features, optional extras and/or colours shown may not be available in your country or may only be available in a different specification. Additionally some models, features, optional extras and/or colours may only be available in combination with others. For current and more specific information in relation to the range of models, features, optional extras and/or colours available in your country, and their pricing, you should contact your nearest authorised Mercedes-Benz Retailer. [www.mercedes-benz.co.uk](http://www.mercedes-benz.co.uk)

Daimler AG, Mercedesstr. 137, 70327 Stuttgart BC/MC 6701 · 1801 · 88-00/1213

