

GR TOYOTA
Supra



5 year
TOYOTA
WARRANTY





GR TOYOTA
Supra

The legend is back. Produced by TOYOTA GAZOO Racing, the development of the new Toyota GR Supra wasn't driven by simple performance numbers or headline lap times, but by a single-minded focus on the feeling you experience at the wheel.

CONDENSED EXTREME DESIGN

Chief Designer, Nobuo Nakamura, gave his team a simple brief for the Toyota GR Supra: the concept of “Condensed Extreme”. Free to express their vision of a pure, individual sports car, they drew on Toyota’s rich heritage to produce a car that’s indisputably modern, yet evokes the romance of classic sports car styling.

The Toyota GR Supra’s “Condensed Extreme” design refers directly to its appearance, evident in its long bonnet, compact body and wide stance. By blending motorsport aerodynamics with a contemporary, powerful look, it screams undiluted driving performance, even at a standstill.



Nobuo Nakamura

CHIEF DESIGNER

“I knew my mission was to create a design that would be visually and physically exciting to sports car fans. By using a front-mounted straight-six engine, rear-wheel drive layout – something rarely seen in today’s cars – I was able to reach something beyond Toyota’s boundaries.”



Tom Matsumoto

Tom Matsumoto

中村暢夫

Nobi Nakamura



FOR THE FEELING





THE SOUL OF TOYOTA SUPRA

A legend among sports car fans, moviegoers and gamers, the Toyota GR Supra has cemented its place in popular automotive culture over the last 40 years. With its long, sweeping bonnet, compact body and double-bubble roof, the new Toyota GR Supra's bloodline can actually be traced back to the 1960s, and the iconic Toyota 2000GT.

The resemblance is more than skin deep though, as a clear thread runs through each generation of the Toyota Supra: a smooth, responsive, in-line straight 6-cylinder front-mounted engine and rear-wheel drive configuration gives the purest driving experience possible.



2000GT
1967



A40
1978



A60
1981



A70
1987



A80
1993

POWERFUL SENSATION

At home on road or track, the Toyota GR Supra's 3.0-litre, in-line straight 6-cylinder engine delivers seamless power and instant response. Featuring a twin-scroll turbocharger, direct fuel injection and variable valve control.

Teamed with an advanced 8-speed, paddle-shift automatic transmission for lightning-fast changes and control. The standard active differential increases stability and grip during braking and cornering.

Power: **340 DIN hp**

Fuel consumption*: **34.4 mpg**

CO₂ emissions*: **188 g/km**

Acceleration 0–62 mph: **4.3 seconds**

Top speed: **155 mph**

* Combined cycle.



High performance stopping power

To help drivers exploit its full dynamic potential, the new Toyota GR Supra's high-performance brakes feature 4-pot Brembo callipers on 19" forged alloy wheels.



Active sound design

The Toyota GR Supra is equipped with Active Sound Design with two selectable driving sounds. For everyday driving, Normal mode provides refined motoring that's perfect at the end of the day, whilst Sport mode delivers spine-tingling high tones and racing-inspired pops during downshifts.





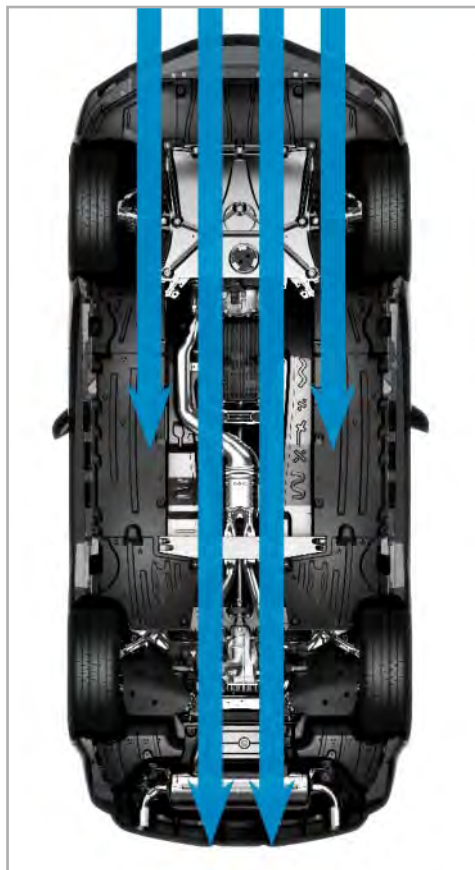

RACING-INSPIRED AERODYNAMICS

TOYOTA GAZOO Racing has been instrumental in honing the Toyota GR Supra's performance. By drawing on its international motorsport expertise, the Toyota GR Supra's design achieves both optimum aerodynamic drag and lift characteristics, as well as an ideal 50:50 front/rear weight balance.

Under the skin, a light but rigid aluminium and steel composite frame ensures the Toyota GR Supra corners with precision. Elsewhere, aluminium control arms and swivel bearings reduce the car's weight, to give you confidence, grip and balance when you need it most.

Underfloor aerodynamics

Aerodynamic performance reaches new levels in the Toyota GR Supra. As well as a double-bubble roof that's designed to reduce drag and an arching rear spoiler that suppresses lift, airflow-regulating fins located underneath the body ensure ground-hugging performance.

PURE FEELING

The new Toyota GR Supra has been conceived as a sports car in its purest form. It combines a short wheelbase and wide track to achieve the ideal 1.55 “golden ratio” and, as a result, provides exceptional agility and stability.

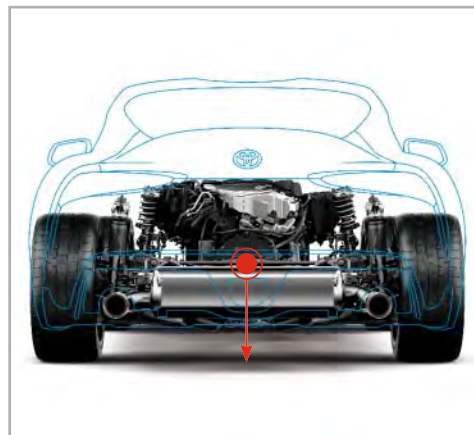

The golden ratio

The best balance between agility and stability is achieved when a car's wheelbase length and tread width ratio is between 1.5 and 1.6. The Toyota GR Supra achieves the ideal 1.55 “golden ratio”, which, when combined with a low centre of gravity and light weight, provides exceptional control and response at the limit.

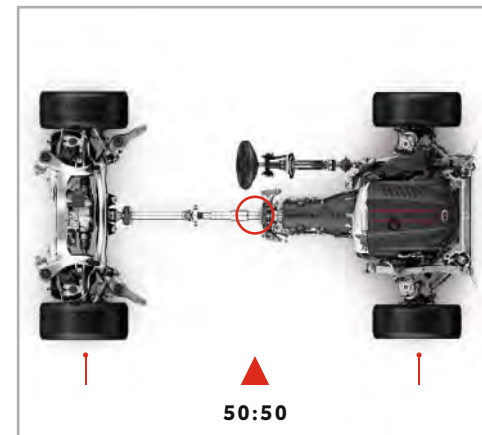

All in the balance

Thanks to a short wheelbase and a traditional front-engined, rear-wheel drive layout, the Toyota GR Supra achieves the perfect 50:50 front-to-rear weight distribution, so you can enjoy neutral handling and seemingly limitless grip.







Focus on what matters

3.0 Pro and A90 Edition grade models are equipped with a Head Up Display (HUD), complementing the driver's instrument panel. The HUD highlights speed, safety features and navigation information clearly in your eyeline, minimising any potential distractions.

* Available on 3.0 Pro and A90 Edition grades.



Modes to suit your mood

Switch between the Toyota GR Supra's two driving modes and feel engine, transmission, damping, steering and differential performance all adjust to suit your preferred driving style. For greater control, engage "Track" to reduce the level of intervention from the Vehicle Stability System.

DRIVER-CENTRIC CABIN

Influenced by the layout of single-seater racing cars, the cabin of the new Toyota GR Supra puts you at the centre of the action. Located around the purposeful, 3-spoke steering wheel, a Head Up Display* and digital combi-meter combine to give you all the information you need, when you need it most.

The Toyota GR Supra's 8.8" central multimedia system provides access to navigation, Toyota Supra Connect, music and hands-free calls, so you can concentrate on the art of driving.

TOYOTA SUPRA CONNECT SERVICES

You don't want anything to distract you when you're behind the wheel of the Toyota GR Supra. That's why we've introduced Toyota Supra Connect, a range of connected services that makes your journey seamless.

Through the Toyota Supra Connect app and portal, you can control and activate a variety of functions remotely, including the Concierge Service and Apple CarPlay™.



Toyota Supra Connect can be downloaded directly from the Apple App Store to your iPhone. Simply create an account and get access to a range of connected services such as "Find my car" or "Lock/Unlock my car".



MyT is a service that enables you to conveniently schedule a service, book maintenance or arrange repairs, via your smartphone. All you need to do to activate MyT is: download the app, create an account and register your vehicle.





Remote control

The Toyota Supra Connect app on your iPhone gives you remote control over your car. If you need to check the fuel level, range and mileage, simply open the app. Should you need to lock and unlock the doors, sound the horn, flash the headlights or change ventilation settings – you can. What's more, it lets you send your next destination to the navigation system from your phone, with one tap.



Connected services

A range of connected services lets you talk to people when you need help – without a phone. The Concierge Service can locate restaurants, book hotels and even update you on the status of your flight. The eCall feature will automatically alert the emergency services in the event of a serious accident. The Breakdown Call feature puts you in touch with a roadside assistant in the event that your vehicle requires technical support.



Smartphone integration

Apple CarPlay™* is a safe and responsible way to enjoy the apps and maps available on your iPhone. For your convenience CarPlay™ transfers the functionality of your iPhone onto the 8.8" touch screen. Toyota GR Supra has the latest wireless CarPlay™ technology so no need for cables and no worries if you left your phone in your briefcase or handbag.

* Currently, only Apple CarPlay™ is offered, Android Auto™ is not available.

TAKE COMFORT IN THE CONTROL

With its asymmetric centre console, racing-inspired seats and premium technology, the new Toyota GR Supra offers the ultimate blend of GT comfort when you want it, and sports car control when you need it. Its power-adjustable leather seats incorporate heating and memory functions, while adjustable side bolsters provide comfort and support.

For added convenience, the Toyota GR Supra's dual-zone air conditioning includes memory-touch switches for each operation, while the 8.8" central multimedia display can be operated as a touch screen, or by using a rotary controller.



A moment to relax

For moments when you want to settle back and relax, the new Toyota GR Supra is equipped with a 10-speaker audio system including Bluetooth® and USB port connections. 3.0 Pro and A90 Edition grades build on this with a 12-speaker JBL premium sound system and wireless mobile phone charger.



A supportive seat

The new Toyota GR Supra's racing-inspired, power-adjustable (including lumbar support) seats incorporate integrated heating and memory functions. (Image shown in black leather, standard on 3.0 Pro.)







Pre-Collision System with Pedestrian and Cyclist Detection

The system, with Cyclist and Night-time Pedestrian Detection, combines a camera with radar technology to detect cyclists and other vehicles on the road, while also detecting pedestrians in low light. When the possibility of a collision is sensed, audio and visual warnings are triggered. If the driver doesn't react, or the brakes aren't applied with enough pressure, the system will automatically engage to prevent or mitigate a collision.



Lane Departure Alert with Steering Control

Using a camera to detect the lane markings in the road ahead, Toyota Safety Sense's Lane Departure Alert will give the driver audible and visual warnings if the vehicle starts to deviate from its lane without the indicator being applied. Steering Control applies corrective force in the case of unintentional lane departure.

A FORCE IN SAFETY

When a sports car can perform at this level, safety is paramount. That's why the Toyota GR Supra is equipped with Toyota Supra Safety+, a suite of technologies that includes Blind Spot Monitor, Lane Departure Alert with Steering Control and Adaptive Cruise Control. A tyre pressure monitoring system (TPMS), temperature alarm and an eCall function that alerts the emergency services in the event of a serious accident add to a sense of all-round confidence, no matter what the situation.

In the city, you are aided by pedestrian and cyclist detection, plus intelligent parking sensors with automatic braking, to keep you and others out of harm's way.

ALL ACTIVE SAFETY TECHNOLOGIES are intended to be back-up systems only and are not a substitute for safe and attentive driving. The functionality of these systems may be impacted by driving conditions. Further information is available from your local Toyota Centre.

PREMIUM FEEL, PURE PERFORMANCE

The Toyota GR Supra combines extraordinary levels of performance with high-end comfort and premium levels of equipment. Toyota GR Supra is always ready to entertain.

3.0 grade main features

- 19" forged alloy wheels
- Active Sports differential
- Toyota Supra Safety+ inc Pre-Collision System with Pedestrian and Cyclist Detection, Adaptive Cruise Control, Lane Departure Alert with steering control, Adaptive Automatic High Beam and Road Sign Assist
- Adaptive Variable Suspension (AVS)
- Drive mode selector
- Rear Cross Traffic Alert (RCTA)
- Blind Spot Monitor (BSM)
- 8.8" Toyota Touch® 2 with Go navigation system with Connected Services
- 10-speaker audio system
- Electrically heated, adjustable Alcantara® sports seats with memory function
- Smart Entry and Push-button Start
- LED adaptive headlights
- LED daytime running lights and rear lights
- Reversing camera
- Red Sports brakes
- eCall





3.0 Pro grade main features (additional to 3.0)

- Black leather Sports seats
- JBL Premium sound system with 12 speakers
- Wireless mobile phone charger
- Head Up Display (HUD)



90 OPPORTUNITIES

The A90 Edition celebrates Toyota Supra's heritage. Finished in Matte Storm Grey paint with 19" matte black forged alloy wheels and red leather upholstery, the exclusive A90 Edition is as thrilling to look at as it is to drive.

An unforgettable finish

Dramatic, sophisticated and sleek, the A90 Edition's exclusive Matte Storm Grey paint makes an unforgettable impression.



Forged for the corners

To aid handling, the A90 Edition's stunning 19" matte black alloy wheels are forged for strength and lightness.



A90 Edition main features (additional to 3.0 Pro)

- 19" forged matte black alloy wheels
- Red leather Sports seats
- Unique paint – Matte Storm Grey



PERFORMANCE ART

The Toyota GR Supra's "Condensed Extreme" design will turn heads whichever colour you choose. With a choice of eight exterior finishes, from the striking Prominence Red to the powerful-looking Ice Grey metallic, your look is sure to impress.



C2Y Ice Grey Metallic*



C10 Deep Blue Metallic*



A61 Prominence Red⁶



A96 White Metallic*



475 Black Metallic*



A83 Silver Metallic*



B21 Lightning Yellow



C3A Matte Storm Grey^o



* Metallic paint.

§ Premium solid paint.

^o Only available on A90 Edition.



SPORTY AND SOPHISTICATED

You will instantly feel the Toyota GR Supra's competition DNA, inside and out. Its racing-inspired sports seats can be wrapped in either sporty Alcantara®, luxurious leather or rich red leather on the A90 Edition grade. Completing the purposeful look are wheel-arch-filling, 19" forged alloys in polished and matte black finishes.

Red leather
Standard on A90 Edition



Black Alcantara®
Standard on 3.0



Black leather
Standard on 3.0 Pro



**19" matte black forged alloy wheels
(5-double-spoke)**
Standard on A90 Edition



**19" black and silver forged alloy wheels
(5-double-spoke)**
Standard on 3.0 and 3.0 Pro



SPECIFICATIONS

ENVIRONMENTAL PERFORMANCE

3.0 Petrol 8-Speed Automatic

Fuel consumption (WLTP)	
Combined (mpg)	34.4
Recommended fuel grade	91 or more (octane)
Fuel tank capacity (l)	52
Carbon dioxide, CO₂ (NEDC equivalent)	
Combined speeds (g/km)	188
Exhaust emissions (Regulation EC/715/2007 as amended by EC 2018/1832 DG)	
Euro class	EURO 6 DG
Carbon monoxide, CO (mg/km)	76.7
Hydrocarbons, THC (mg/km)	12.6
Hydrocarbons, NMHC (mg/km)	9.2
Nitrogen Oxides, NOx (mg/km)	9.3
Sound level drive by (dB(A))	68

Quoted mpg and CO₂: Figures are provided for comparability purposes; only compare fuel consumption and CO₂ figures with other cars tested to the same technical procedures. These figures may not reflect real-life driving results.

All vehicles are certified according to the World Harmonised Light Vehicle Test Procedure (WLTP). CO₂ figures (and hence car tax and recommended “on the road” prices) may differ from information printed before 1 April 2020, due to a change in the official method of calculation. This date may change; please visit www.vehicle-certification-agency.gov.uk/fcb/wltp.asp for the latest information.

Please contact your local Toyota Centre for further information.

ENGINE	3.0 Petrol 8-Speed Automatic
Engine code	B58B30M1
Number of cylinders	6, in line
Fuel system	Direct injection
Displacement (cc)	2998
Bore x stroke (mm x mm)	82.0 x 94.6
Compression ratio	11.0:1
Maximum power output (DIN hp)	340
Maximum power output (kW/rpm)	250/6500
Maximum torque (Nm/rpm)	500/1600–4500
PERFORMANCE	3.0 Petrol 8-Speed Automatic
Maximum speed (mph)	155
Acceleration 0–62 mph (secs)	4.3
WEIGHTS	3.0 Petrol 8-Speed Automatic
Total gross vehicle mass (kg)	1815
Kerb weight (kg)	1390–1495
SUSPENSION	3.0 Petrol 8-Speed Automatic
Front	MacPherson strut
Rear	Multi-link
BRAKES	3.0 Petrol 8-Speed Automatic
Front	Ventilated disc
Rear	Ventilated disc

SPECIFICATIONS

INTERIOR DIMENSIONS & LOAD VOLUME

2-door Coupe

Number of seats	2
Interior width (mm)	1460
Interior height (mm)	972
VDA capacity up to roof (1st row up, litres)	290

EXTERIOR DIMENSIONS

2-door Coupe

Exterior length (mm)	4378
Exterior width (mm)	1853
Exterior height (mm)	1292
Front tread (mm)	1594
Rear tread (mm)	1589
Front overhang (mm)	958
Rear overhang (mm)	951
Wheelbase (mm)	2470
Min. running ground clearance (mm)	115

STEERING

2-door Coupe

Turning circle – tyre (m)	10.4
---------------------------	------

WHEELS

3.0

3.0 Pro

A90 Edition

19" black & silver forged alloy wheels (5-double-spoke)	●	●	–
19" matte black forged alloy wheels (5-double-spoke)	–	–	●
Tyre repair kit	●	●	●

● = Standard ○ = Optional – = Not available



1594 mm

1853 mm



951 mm

2470 mm

958 mm

4378 mm

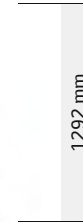

1292 mm



1589 mm

1853 mm

EQUIPMENT

EXTERIOR STYLING	3.0	3.0 Pro	A90 Edition
LED front light guide	●	●	●
Glass-integrated antenna	●	●	●

EXTERIOR COMFORT	3.0	3.0 Pro	A90 Edition
LED automatic headlights	●	●	●
Follow-me-home headlights	●	●	●
Automatic wipers	●	●	●
Power-adjustable door mirrors	●	●	●
Heated door mirrors	●	●	●
Auto-retractable door mirrors	●	●	●
Reverse-gear tilting door mirrors	●	●	●
Electrochromatic door mirrors	●	●	●
Memory function on door mirrors	●	●	●
Remote door locks	●	●	●

INTERIOR STYLING	3.0	3.0 Pro	A90 Edition
Aluminium pedals	●	●	●
Electronic parking brake	●	●	●
Aluminium door scuff plates	●	●	●

INTERIOR COMFORT	3.0	3.0 Pro	A90 Edition
Smart Entry & Push-button Start	●	●	●
Digital speedometer (mph)	●	●	●
Digital tachometer	●	●	●
Variable Gear Ratio System (VGRS) power steering	●	●	●
Paddle shifts	●	●	●
Electrochromatic auto-dimming rear-view mirror	●	●	●
Dual-zone automatic air conditioning	●	●	●
Heated, power height-adjustable, sliding, reclining front seats with lumbar support	●	●	●
Power-tilting cushion & memory function on driver seat	●	●	●
Centre room light	●	●	●

INTERIOR COMFORT	3.0	3.0 Pro	A90 Edition
Boot light	●	●	●
Front footwell lights	–	●	●
Door courtesy light	–	●	●
Light and mirror on driver and passenger sun visors	●	●	●
12V front power outlet	●	●	●
12V boot power outlet	–	●	●
Wireless mobile phone charger	–	●	●
Power door locks	●	●	●
Head Up Display (HUD)	–	●	●
Gear Shift Indicator (GSI)	●	●	●
Audio, multimedia and telephone switches on steering wheel	●	●	●
Adaptive Cruise Control (ACC) switch on steering wheel	●	●	●
Adjustable Speed Limiter (ASL) switch on steering wheel	●	●	●

STORAGE	3.0	3.0 Pro	A90 Edition
Glovebox light	–	●	●
Front cup holders	●	●	●
Driver & passenger seatback pockets	●	●	●

MULTIMEDIA	3.0	3.0 Pro	A90 Edition
Toyota Supra Connect	●	●	●
Digital Audio Broadcasting (DAB)	●	●	●
Bluetooth® connectivity	●	●	●
8.8" Toyota Touch® 2 with Go navigation	●	●	●
10 speakers	●	–	–
JBL premium sound system with 12 speakers	–	●	●
1.5 amp USB connector	●	–	–
2.1 amp USB connector	–	●	●
Voice recognition	●	●	●

● = Standard ○ = Optional – = Not available

EQUIPMENT

SAFETY	3.0	3.0 Pro	A90 Edition
Red sports front & rear brake pads	●	●	●
Emergency Brake-light Signal (EBS)	●	●	●
LED high-mounted stop light	●	●	●
LED dual-beam projector headlights	●	●	●
Vehicle Stability Control (VSC)	●	●	●
Adaptive Automatic High Beam	●	●	●
Automatic headlamp levelling	●	●	●
LED daytime running lights	●	●	●
Cornering lights	●	●	●
LED turning signal	●	●	●
Blind Spot Monitor (BSM)	●	●	●

SAFETY	3.0	3.0 Pro	A90 Edition
Adaptive Cruise Control with Full Stop & Start Functionality	●	●	●
Intelligent Adaptive Cruise Control	●	●	●
Reversing camera	●	●	●
Immobiliser	●	●	●
Intrusion sensor	●	●	●
Front & rear parking sensors	●	●	●
Tilt detection sensors	●	●	●
Traction Control (TRC)	●	●	●
Pre-Collision System with Pedestrian and Cyclist Detection	●	●	●
Rear-end Collision Warning	●	●	●

SAFETY	3.0	3.0 Pro	A90 Edition
Lane Departure Alert with Steering Control	●	●	●
Rear Cross Traffic Alert (RCTA)	●	●	●
Road Sign Assist	●	●	●
eCall emergency call system	●	●	●
Tyre Pressure Monitoring System (TPMS)	●	●	●
Supplemental Restraint System (SRS) airbags – 7 airbags	●	●	●
Front seat belt reminder	●	●	●

PERFORMANCE, TRANSPORT AND PROTECTION	3.0	3.0 Pro	A90 Edition
Drive mode selector	●	●	●
Adaptive Variable Suspension (AVS)	●	●	●
Active Sports differential	●	●	●
Dual exhaust pipes	●	●	●
Stop & Start System	●	●	●

● = Standard ○ = Optional – = Not available



FOR THE FEELING

WWW.TOYOTA.CO.UK/GRSUPRA

While every effort is made to reproduce accurate information, we reserve the right to change specifications, equipment and availability without prior notice. This brochure cannot be regarded as infallible (some of the vehicles shown may not be to exact UK specification), and as such does not constitute an offer for sale of any particular vehicle or specification. For the latest specification and availability, we ask that you contact your local Toyota Centre. Vehicle body colours may differ slightly from the printed images in this brochure.

Quoted mpg and CO₂: Figures are provided for comparability purposes; only compare fuel consumption and CO₂ figures with other cars tested to the same technical procedures. These figures may not reflect real-life driving results. Fuel consumption and CO₂ produced varies significantly depending on a number of factors, including the accessories fitted (post-registration), driving style, conditions, speed and vehicle load.

All models and grades are certified according to the World Harmonised Light Vehicle Test Procedure (WLTP). All mpg and CO₂ figures quoted are full WLTP figures.

The official CO₂ figures for vehicles will change as from 1 April 2020, due to a change in the official method of calculation. CO₂ figures are used in the calculation of Vehicle Excise Duty (car tax) for new cars during their first year of registration. As a result, all CO₂ figures, car tax and 'on the road' prices for new vehicles, which were provided or displayed prior to 1 April 2020, may now have changed for vehicles which were not registered before that date. These dates may change, please visit www.vehicle-certification-agency.gov.uk/fcb/wltp.asp for the latest information.

Please contact your local Toyota Centre for further information.

© 2020 by Toyota Motor Europe NV/SA ("TME"). No part of this publication may in any way be reproduced without the prior written approval of Toyota (GB) PLC.



Toyota UK



@ToyotaGB

GBNGV-0420B-SA March 2020