



# The EQE

Effective from March 2022 Production.

MERCEDES-EQ





Book a test drive



Buy your EQE



Find a Retailer



Some of the model features, optional extras and colours shown may not be available, or may only be available in a different specification, or at a different price.

Design	Sustainability	Technology	Safety	Mercedes-EQ	Model lines	Upholstery	Model prices	Personalisation	Standard equipment	Genuine accessories	Technical data	Additional information
--------	----------------	------------	--------	-------------	-------------	------------	--------------	-----------------	--------------------	---------------------	----------------	------------------------





Book a test drive



Buy your EQ



Find a Retailer



Some of the model features, optional extras and colours shown may not be available, or may only be available in a different specification, or at a different price.

Design	Sustainability	Technology	Safety	Mercedes-EQ	Model lines	Upholstery	Model prices	Personalisation	Standard equipment	Genuine accessories	Technical data	Additional information
--------	----------------	------------	--------	-------------	-------------	------------	--------------	-----------------	--------------------	---------------------	----------------	------------------------



Book a test drive



Buy your EQ



Find a Retailer



Some of the model features, optional extras and colours shown may not be available, or may only be available in a different specification, or at a different price.

Design	Sustainability	Technology	Safety	Mercedes-EQ	Model lines	Upholstery	Model prices	Personalisation	Standard equipment	Genuine accessories	Technical data	Additional information
--------	----------------	------------	--------	-------------	-------------	------------	--------------	-----------------	--------------------	---------------------	----------------	------------------------





Book a test drive



Buy your EQ



Find a Retailer

EQE

# Sustainability



Design

Sustainability

Technology

Safety

Mercedes-EQ

Model lines

Upholstery

Model prices

Personalisation

Standard  
equipment

Genuine  
accessories

Technical data

Additional  
information



Book a test drive



Buy your EQE



Find a Retailer

# Sustainable production.

All our Mercedes-Benz factories around the world plan to be CO<sub>2</sub> neutral by 2022.



# Sustainable materials.

To ensure the responsible mining of cobalt, lithium and other battery raw materials, Mercedes-Benz has already made the IRMA Standard for Responsible Mining a contractual component for all future vehicle projects.

# Sustainable mobility.

Locally emission-free driving pleasure, virtually silent with full access to inner city zones. All our EQ vehicles come as standard with an external acoustic warning to alert pedestrians or cyclists at speeds under 19 mph.



Design

Sustainability

Technology

Safety

Mercedes-EQ

Model lines

Upholstery

Model prices

Personalisation

Standard equipment

Genuine accessories

Technical data

Additional information





Book a test drive



Buy your EQE



Find a Retailer

# Mercedes me Charge - Green charging



To promote the use of electricity from renewable energies, Mercedes-Benz uses guarantees of origin to 'green' the charging process.

This ensures that an equivalent amount of electricity from renewable resources is fed into the grid to compensate for the charging of your EQE.

All new EQEs have three years of Mercedes me Charge as standard and the Green Charging guarantee is included with this.

Design	<b>Sustainability</b>	Technology	Safety	Mercedes-EQ	Model lines	Upholstery	Model prices	Personalisation	Standard equipment	Genuine accessories	Technical data	Additional information
--------	-----------------------	------------	--------	-------------	-------------	------------	--------------	-----------------	--------------------	---------------------	----------------	------------------------





Book a test drive



Buy your EQ



Find a Retailer



EQE

# Technology

Design	Sustainability	Technology	Safety	Mercedes-EQ	Model lines	Upholstery	Model prices	Personalisation	Standard equipment	Genuine accessories	Technical data	Additional information
--------	----------------	------------	--------	-------------	-------------	------------	--------------	-----------------	--------------------	---------------------	----------------	------------------------



## Mercedes me connect Stay connected any time, anywhere.

Mercedes me is a range of innovative online services designed to enhance your Mercedes-Benz experience. Accessible via mobile, tablet or PC, Mercedes me lets you enjoy the highest standards of care and support, in a way that integrates seamlessly with your busy lifestyle.

### Safety and Service – Mercedes me connect helps to keep you and your car safe

Check your car's washer fluid level, tyre pressure and battery level from your phone so you'll be ready for every journey.

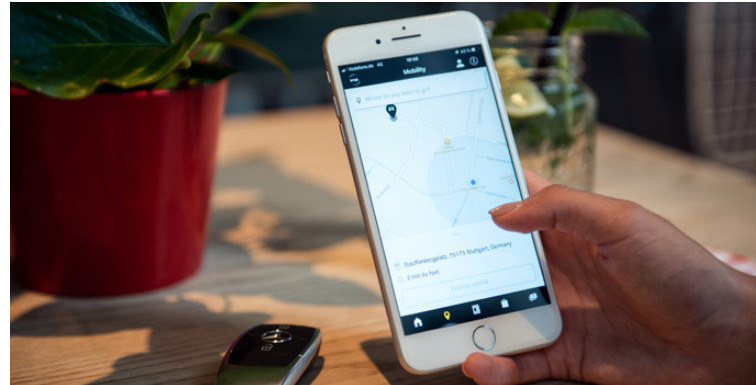

### Infotainment – Online and Entertainment services from Mercedes me connect

Love music? Get a 3-month free subscription to Tidal when you connect your car.

### Live Traffic Information, Parked Vehicle Locator and much more with Mercedes me connect

Forgot where you've parked? Parked Vehicle Locator<sup>1</sup> will show you exactly where your car is as long as you're in a 1-mile radius of where you parked. Real-time traffic data and dynamic route with shorter journey times.

For more information speak to your local Retailer or visit the Mercedes me connect store at [shop.mercedes-benz.com/en-gb/connect](http://shop.mercedes-benz.com/en-gb/connect)

### Comfort – connect to your car anytime, anywhere

Forgot to lock your car? With Remote Car Lock<sup>2</sup> you will receive a notification on your smartphone to let you know. With one tap, you can lock and unlock your vehicle so you never have to worry.

### Mercedes-EQ specific services

Check your charging status on the go and programme your pre-entry climate control and charging settings remotely. The Mercedes-EQ specific navigation considers electrical range, topography and charging stations.

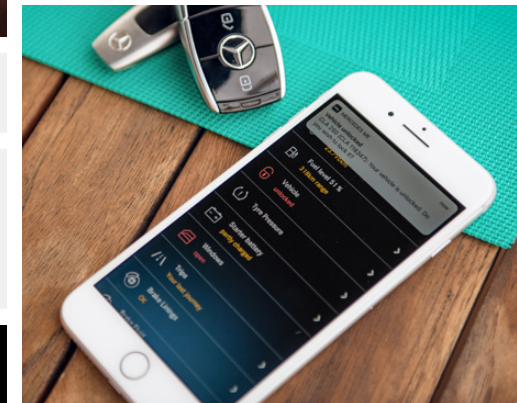

<sup>1</sup>Available on all models with the Vehicle Monitoring package. This option may vary between standard and additional cost dependent on the model

<sup>2</sup>Part of the Vehicle Status package. This option may vary between standard and additional cost dependent on the model

Images shown are for illustration purposes only

[Book a test drive](#)[Buy your EQE](#)[Find a Retailer](#)

# Mercedes-Benz User Experience (MBUX)

Transforming the in-car user experience, thanks to MBUX: Controlled via voice, touch or gesture (where fitted) input, the innovative infotainment system can over time even predict personal habits thanks to artificial intelligence.

## Voice control

- Activated by the keywords “Hey Mercedes”, the new intelligent voice control LINGUATRONIC<sup>1</sup> lets you control many of the infotainment functions, including destination input, phone calls or music selection
- MBUX is able to understand different accents and will adjust to you over time
- MBUX even understands indirect commands. Feeling chilly? Just say “I feel cold” and MBUX will adjust the temperature for you
- MBUX is able to understand which individual seat the request has come from, and will therefore only respond to their specific request (e.g. adjusting the temperature for just the front passenger)

## Touch inputs

- Beside voice control you can operate MBUX via touchscreen, the touch controls on the centre console, as well as touch control buttons on the steering wheel

## Personalisation

- Turn the new EQE into your very own Mercedes-Benz by personalising driving modes, radio stations, ambient lighting and much more
- Your personal settings can be saved in up to seven different profiles, making your driving experience the best one possible
- Thanks to artificial intelligence, MBUX is able to learn and adapt over time. It will be able to predict your personal habits, such as navigation for frequently-driven routes, or the radio station you like to listen to on your way home from work

## Maintenance and service

- Wondering when the next service is due? Or how much further you can drive until you need to stop at a charging station? Just ask your MBUX – it will tell you the answer



MBUX multimedia system

<sup>1</sup>LINGUATRONIC off-board functions are currently only available for three years

<a href="#">Design</a>	<a href="#">Sustainability</a>	<a href="#">Technology</a>	<a href="#">Safety</a>	<a href="#">Mercedes-EQ</a>	<a href="#">Model lines</a>	<a href="#">Upholstery</a>	<a href="#">Model prices</a>	<a href="#">Personalisation</a>	<a href="#">Standard equipment</a>	<a href="#">Genuine accessories</a>	<a href="#">Technical data</a>	<a href="#">Additional information</a>
------------------------	--------------------------------	----------------------------	------------------------	-----------------------------	-----------------------------	----------------------------	------------------------------	---------------------------------	------------------------------------	-------------------------------------	--------------------------------	--



EQE

# Safety



[Book a test drive](#)[Buy your EQE](#)[Find a Retailer](#)

# DIGITAL LIGHT

 High-definition headlamps with innovative features

The new innovative DIGITAL LIGHT headlamps works like a projector with more than one million pixels per headlamp and responds with brilliant light to changing traffic, road or weather conditions. Its ULTRA RANGE Highbeam with 650 m makes you feel like driving at daylight.

**Standard on AMG Line Premium Plus and Exclusive Luxury**







Book a test drive



Buy your EQE



Find a Retailer

# Driving Assistance package and Driving Assistance package Plus Cares for what matters.

The new EQE comes with standard ground-breaking innovations in safety, comfort and driving functions, to help you stay safe on the road.

## Driving Assistance package (code P79) – designed and priced as a package Standard on AMG Line Premium

**Active Distance Assist DISTRONIC** now responds to stationary road users to prevent collisions up to 80 mph (previously 37 mph)

**Active Lane Keeping Assist** with enhanced comfort thanks to active steering intervention (instead of braking intervention) and additional hazard indication

### Blind Spot Assist

## Driving Assistance package Plus (code P20) – designed and priced as a package Standard on AMG Line Premium Plus and Exclusive Luxury

**Active Blind Spot Assist** expanded with blind spot monitoring towards the front and side. Additional hazard indication of the blind spot warning system as well as exit warning function

**Active Brake Assist with cross-traffic function** now with turning manoeuvre function (responding to (among other things) crossing pedestrians when making a turn). Operating range on urban routes expanded to 74 mph (previously 44 mph)

**Active Distance Assist DISTRONIC** now responds to stationary road users to prevent collisions up to 80 mph (previously 37 mph)

**Active Emergency Stop Assist:** now able to assist in manual mode (previously on in DISTRONIC mode). Optional lane change by one lane (at 49 mph where no obstacles detected)

**Active Evasive Steering Assist:** now responds to cyclists and ends of tailbacks in addition to pedestrians. Operating range on urban routes expanded to 67 mph (previously 44 mph)

**Active Lane Keeping Assist** with enhanced comfort thanks to active steering intervention (instead of braking intervention) and additional hazard indication

**Active Speed Limit Assist** ensures detected speed limits are automatically adopted as the set speed for Active Distance Assist DISTRONIC

### Congestion emergency braking function

### Emergency corridor function

### Exit warning function when hand moves towards the door handles

### Extended automatic restart on motorways

### Hazard display via ambience lighting

Increased availability and cornering performance on carriageways with **Active Steering Assist**, more stern warnings to put hands on the steering wheel with new capacitive steering wheel

**PRE-SAFE® PLUS and Impulse Side with body-raising function:** when a rear-end collision threatens, PRE-SAFE® PLUS can initiate preventive measures, including warning following traffic and locking the brakes on standstill

**Route-based speed adjustment with end of traffic jam function and Active Stop-and-Go Assist** adaption of speed before curves, roundabouts and junctions with end of traffic jam function



Active Lane Keeping Assist



Active Brake Assist

Design

Sustainability

Technology

Safety

Mercedes-EQ

Model lines

Upholstery

Model prices

Personalisation

Standard equipment

Genuine accessories

Technical data

Additional information



Book a test drive



Buy your EQ



Find a Retailer

EQE

# Mercedes-EQ



Design	Sustainability	Technology	Safety	Mercedes-EQ	Model lines	Upholstery	Model prices	Personalisation	Standard equipment	Genuine accessories	Technical data	Additional information
--------	----------------	------------	--------	-------------	-------------	------------	--------------	-----------------	--------------------	---------------------	----------------	------------------------





Book a test drive



Buy your EQE



Find a Retailer

# Benefits of driving Mercedes-EQ

MERCEDES-EQ

The EQE – 100% Electric Saloon from Mercedes-EQ.

## Lower running costs

Did you know that electric cars could cost up to a third less than a diesel or petrol car to run, as well as being cheaper to maintain? We've partnered with Go Ultra Low, a joint Government and car industry campaign, to give you unbiased advice on making the switch to an electric car. Use Go Ultra Low's cost saving calculator to see how much you can save.

[› Discover more](#)

## No road fund licence

Mercedes-EQ vehicles have no local emissions – this means you pay no road tax.

## Cleaner vehicle discount

Mercedes-EQ battery electric vehicles are congestion charge and ultra low emission zone charge exempt in London and other cities.

## Business benefits

With 100% first-year capital allowances<sup>1</sup> and 2% BIK tax, electric cars offer significant benefits to businesses and employees.

## Performance

Instant torque provides a whole new dimension to driving performance.

## Refinement

Acoustically optimised glass and a near-silent powertrain means that driving Mercedes-EQ provides a sensory experience of luxurious refinement.



[› Click here for more information](#)

<sup>1</sup>100% first-year capital allowances only apply to vehicles less than 50 g CO<sub>2</sub>/km

Design	Sustainability	Technology	Safety	Mercedes-EQ	Model lines	Upholstery	Model prices	Personalisation	Standard equipment	Genuine accessories	Technical data	Additional information
--------	----------------	------------	--------	-------------	-------------	------------	--------------	-----------------	--------------------	---------------------	----------------	------------------------

[Book a test drive](#)[Buy your EQ](#)[Find a Retailer](#)

# EQE

# MERCEDES-EQ

Vehement power immediately from standstill: An electric motor at the rear axle converts electrical into mechanical energy, and delivers impressive forward thrust. The intelligent operating strategy of the powertrain components supplies the power always wherever it is needed at the moment – efficiently and nearly silently.

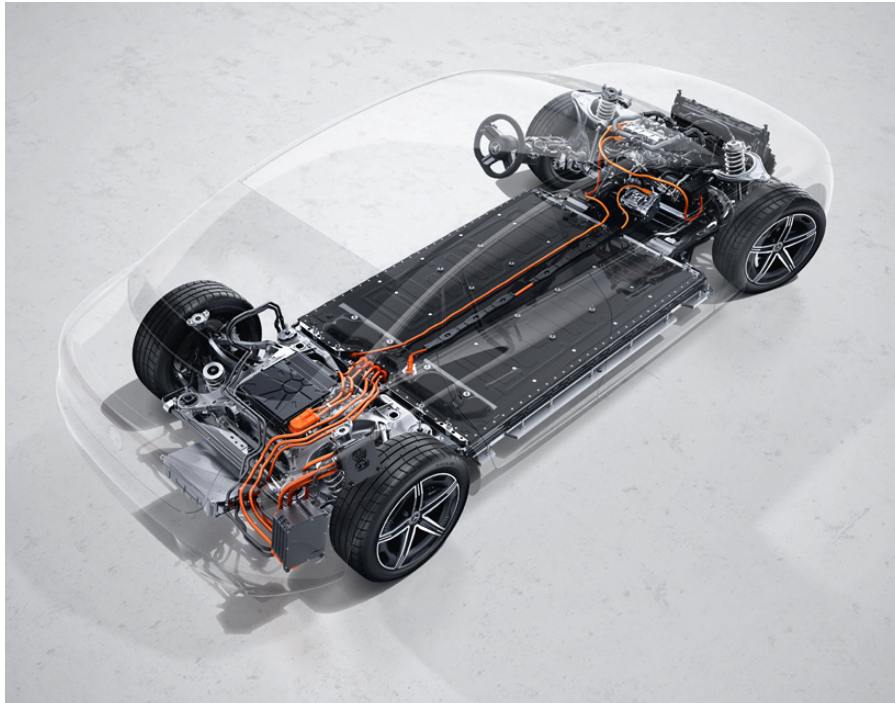

## EQE 350+

Battery electric vehicle, 292 hp/215 kW  
Electric range: 356–394 miles – WLTP

OTR from **£76,450<sup>1</sup>**

### Standard equipment

AIRMATIC air suspension

Charging system – AC charging system rated at 22 kW AC

Charging system – DC charging system rated at 170 kW DC

Charging socket

Charging cable for wallbox and public charging stations, Type 2 (Mode 3) – 5 metres

Pre-entry climate control

Radar-based recuperation

### Technical details

Electric range <sup>2</sup>	356–394 miles
Charging time	
Charging speed AC fast charge – 22 kW	
80% charging time on AC 22 kW charging <sup>3,4</sup>	4 hrs 15 mins
Charging speed DC rapid – 170 kW	
10–80% charging time on DC rapid charging <sup>3,4</sup>	32 mins
Range power consumption, combined <sup>2,3</sup>	183–171 Wh/km
Battery type (capacity)	lithium-ion (90 kWh)
Capacity on-board charger	22 kW AC; 170 kW DC

### Attention



Please be aware that external factors such as weather, gradient and ambient temperature amongst others can significantly impact range.



Please also note that internal factors such as driving style and climate control settings etc. can also significantly impact range.



Using the pre-entry climate control when plugged into a charge point will ensure the perfect ambience and ensure that your car is just how you like it, as well as making sure that your battery isn't used unnecessarily to heat/cool the vehicle (maximising range).

<sup>1</sup>The recommended on-the-road price includes the Road Fund Licence applicable to the standard model plus delivery charge (£780.00 incl. VAT), new vehicle registration fee (£55.00) and number plates (£25.00 incl. VAT). VAT is calculated at the standard rate of 20%. Some of the model features, optional extras and colours shown may not be available, or may only be available in a different specification, or at a different price. <sup>2</sup>Figures shown are for comparability purposes; only compare with other cars tested to the same technical procedures. Figures may not reflect real life driving results, which will depend upon a number of factors including the starting charge of the battery, factory-fitted options, accessories fitted (post registration), variations in weather, driving styles and vehicle load. Further information about the test used to establish range, power consumption and CO<sub>2</sub> figures can be found at <http://www.mercedes-benz.co.uk/WLTP> <sup>3</sup>Specified voltage and current values refer to network infrastructure and can be limited by the vehicle. Times are from 10–80% charge using public rapid charging at 110 kW <sup>4</sup>Specified voltage and current values refer to network infrastructure and can be limited by the vehicle. Times are from 10–100% charge using a wallbox (three-phase) or standard socket (single-phase) <sup>5</sup>If you are planning to charge your Mercedes-Benz plug-in electric vehicle using a 3-pin domestic plug socket you must get a qualified electrician to inspect and sign off the socket to confirm it is safe and suitable to charge your vehicle. Do not use an electric vehicle 3-pin charge cable with an extension cord)



[Book a test drive](#)[Buy your EQE](#)[Find a Retailer](#)

# Mercedes me Charge One registration, one contract, one billing.

# Mercedes *me*

Mercedes me Charge provides access to a multitude of public charging stations located in shopping centers, hotels or at motorway services. A smartphone app as well as the vehicle's navigation system show the precise location, current availability and price at the selected charging station.

### Tens of thousands charging stations in the UK

Growing network of charging providers includes bp pulse the largest charging network in the UK. Customers also get six months free bp pulse membership which reduces the electricity price when charging.



### Access to fast-charging stations

Enables customers to get access to charging stations of different providers with:

- Mercedes me app
- RFID card
- Mercedes-EQ Vehicle Head unit

### Green charging

All charging using Mercedes me Charge, will be retrospectively 'greened' by Mercedes-Benz. Please click [here](#) for more info.

### Transparent and easy billing

One invoice charging processes for payment.

### Easy access

Charging stations are displayed in Mercedes me app and in MBUX multimedia system.

### No fees

Mercedes me Charge is standard for three years with discounted IONITY rapid-charging for one year.



<a href="#">Design</a>	<a href="#">Sustainability</a>	<a href="#">Technology</a>	<a href="#">Safety</a>	<a href="#">Mercedes-EQ</a>	<a href="#">Model lines</a>	<a href="#">Upholstery</a>	<a href="#">Model prices</a>	<a href="#">Personalisation</a>	<a href="#">Standard equipment</a>	<a href="#">Genuine accessories</a>	<a href="#">Technical data</a>	<a href="#">Additional information</a>
------------------------	--------------------------------	----------------------------	------------------------	-----------------------------	-----------------------------	----------------------------	------------------------------	---------------------------------	------------------------------------	-------------------------------------	--------------------------------	--



Book a test drive



Buy your EQE



Find a Retailer

# Home charging Simple, convenient, fast charging.



Mercedes-Benz plug-in vehicle customers with off-street parking can benefit from the convenience and speed of charging at home by installing a home charger. Simply charge your EQE overnight – the 7 kW home charger delivers a full charge in 14 hours and 30 minutes.<sup>1</sup>

## Home charger 7 kW: **£875\*** incl. VAT & installation

### Key benefits of the 7 kW home charger:

Robust and weatherproof, for indoor or outdoor use, and comes with a three year warranty. Keep track of your charging using your chosen providers' app – available on both the App Store and the Google Play Store.

### OZEV Grant:

You may be entitled to claim for an OZEV grant towards the cost of your home charger.<sup>2</sup> To find out whether you are entitled please contact your chosen charging partner.

**Questions?** Please contact your local Retailer to submit an enquiry to your chosen charging partner on your behalf. To find your local Retailer, please click the button at the top right hand corner.

**Warning!** If you are planning to charge your Mercedes-Benz plug-in electric vehicle using a 3-pin domestic plug socket you must get a qualified electrician to inspect and sign off the socket to confirm it is safe and suitable to charge your vehicle. Do not use an electric vehicle 3-pin charge cable with an extension cord.



<sup>1</sup>Price excludes £350 OZEV EVHS Grant. Price correct at time of publication, subject to change

<sup>2</sup>Based on 7 kW power output <sup>2</sup>The home charger £350 Grant (including VAT) is only available to customers who meet the criteria of the Office for Zero Emission Vehicles (OZEV). For full details and eligibility criteria for the OZEV EVHS Grant, see <https://www.gov.uk/government/publications/electric-vehicle-homecharge-scheme-guidance-for-customers-version-21>.

Design	Sustainability	Technology	Safety	Mercedes-EQ	Model lines	Upholstery	Model prices	Personalisation	Standard equipment	Genuine accessories	Technical data	Additional information
--------	----------------	------------	--------	-------------	-------------	------------	--------------	-----------------	--------------------	---------------------	----------------	------------------------





Book a test drive



Buy your EQE



Find a Retailer

# EQE Model lines overview



**AMG Line »**



**AMG Line Premium »**



**AMG Line Premium Plus »**



**Exclusive Luxury »**

Design	Sustainability	Technology	Safety	Mercedes-EQ	Model lines	Upholstery	Model prices	Personalisation	Standard equipment	Genuine accessories	Technical data	Additional information
--------	----------------	------------	--------	-------------	-------------	------------	--------------	-----------------	--------------------	---------------------	----------------	------------------------

# EQE AMG Line



## High specification as standard.

The EQE AMG Line features a strong standard specification inside and outside. On the exterior, the AMG exterior styling along with 19" AMG 5-twin spoke wheels, and the panoramic roof ensure for a sporty styling. The interior features the AMG multifunction

sports steering wheel in nappa leather, AMG brushed stainless steel sport pedals and AMG sports seats with heated front seats.

## EQE AMG Line

**OTR from £76,450<sup>1</sup>**

<sup>1</sup>The recommended on-the-road price includes the Road Fund Licence applicable to the standard model plus delivery charge (£780.00 incl.VAT), new vehicle registration fee (£55.00) and number plates (£25.00 incl.VAT). VAT is calculated at the standard rate of 20%. Some of the model features, optional extras and colours shown may not be available, or may only be available in a different specification, or at a different price

Design	Sustainability	Technology	Safety	Mercedes-EQ	Model lines	Upholstery	Model prices	Personalisation	Standard equipment	Genuine accessories	Technical data	Additional information
--------	----------------	------------	--------	-------------	-------------	------------	--------------	-----------------	--------------------	---------------------	----------------	------------------------



# EQE AMG Line Standard equipment highlights



## Exterior

19" AMG alloy wheels – 5-twin-spoke design, aerodynamically optimised, painted black with a high-shine finish (code RRH)

AMG exterior styling – AMG front bumper painted in vehicle colour with A-wing in high-gloss black and trim in chrome, front splitter in high-gloss chrome with flics and fins at the left and right air inlets in high-gloss black with chrome trim. AMG rear apron painted in vehicle colour with diffuser-look inserts in high-gloss black, double trim strip in chrome and flics at the left and right air outlets in grained black. Side skirts painted in high-gloss black with insert in chrome

Panoramic roof

Privacy glass

Summer tyres





Parking package with Parking Assist and reversing camera

**Communications, Safety and Assistance Systems**

- 12.3-inch digital instrument cluster display
- 12.8-inch media display
- Parking package with Parking Assist and reversing camera
- URBAN GUARD vehicle protection



**Interior**

- |  |  |
|--|--|
| Air Quality package  | AMG sports seats in Lugano leather upholstery  |
| Ambient lighting – three dimming zones (all, ambient and accent), variable brightness setting, 64 colours and ten colour moods | Dashboard and beltlines in grey ARTICO man-made leather with NEOTEX grain and red topstitching |
| AMG brushed stainless steel sports pedals with black rubber studs  | Heated front seats   |
| AMG floor mats   | Roof liner in black fabric   |
| AMG multifunction sports steering wheel in nappa leather   | THERMATIC automatic climate control with two climate zones                                     |

**Trim and Upholstery**

- |  |                                    |
|--|------------------------------------|
| ARTICO man-made leather/MICROCUT microfibre – black/space grey | Anthracite linestructure lime wood |
|--|------------------------------------|





# EQE AMG Line Premium



## Take your EQE to the next level.

Elevating the specification of the AMG Line, the AMG Line Premium benefits of additional features, such as 20" AMG 5-spoke-design wheels and the Driving Assistance package Plus. Designed around sensory excellence, the interior features Ambient lighting and the

THERMOTRONIC automatic climate control. Thanks to KEYLESS-GO, all doors can then be unlocked and locked simply by touching the door handle.

**EQE AMG Line Premium**  
**Upgrade price from EQE AMG Line**

**OTR from £81,450<sup>1</sup>**  
**£5,000**

<sup>1</sup>The recommended on-the-road price includes the Road Fund Licence applicable to the standard model plus delivery charge (£780.00 incl. VAT), new vehicle registration fee (£55.00) and number plates (£25.00 incl. VAT). VAT is calculated at the standard rate of 20%. Some of the model features, optional extras and colours shown may not be available, or may only be available in a different specification, or at a different price

Design	Sustainability	Technology	Safety	Mercedes-EQ	Model lines	Upholstery	Model prices	Personalisation	Standard equipment	Genuine accessories	Technical data	Additional information
--------	----------------	------------	--------	-------------	-------------	------------	--------------	-----------------	--------------------	---------------------	----------------	------------------------

# EQE AMG Line Premium Standard equipment highlights



In addition to/replacement of AMG Line:

### Exterior

20" AMG alloy wheels – 5-spoke design, painted metallic vanadium silver with aero elements in matt tantalite grey (code RRM)

Summer tyres







### Interior

Ambient Lighting Plus - in 64 colours, all colours can be selected individually, ambient lighting (code 891) with indirect illumination  
Pre-programmed colour schemes which illuminate defined areas of the interior in different colours, contour lighting of the seats, dynamic mode: the colours alternate slowly, emotively appealing animations: welcome display or feedback in colour when adjusting the air conditioning

KEYLESS-GO

Memory package

THERMOTRONIC automatic climate control with four climate zones

### Communications, Safety and Assistance Systems

Driving Assistance package

Mercedes-Benz sound system



### Trim and Upholstery

ARTICO man-made leather/MICROCUT microfibre - black/space grey

Anthracite linestructure lime wood

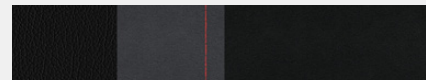

# EQE AMG Line Premium Plus



## Boosting the spec further.

The AMG Line Premium Plus has been designed to enhance the driving experience through greater comfort and ease of use. 21" multi-spoke alloy wheels, AIRMATIC air suspension, as well as the MBUX Interior Assistant (front), head-up display, and the Parking package with 360° camera all come as standard.

**EQE AMG Line Premium Plus**  
**Upgrade price from EQE AMG Line Premium**

**OTR from £88,450<sup>1</sup>**  
**£7,000**

<sup>1</sup>The recommended on-the-road price includes the Road Fund Licence applicable to the standard model plus delivery charge (£780.00 incl. VAT), new vehicle registration fee (£55.00) and number plates (£25.00 incl. VAT). VAT is calculated at the standard rate of 20%. Some of the model features, optional extras and colours shown may not be available, or may only be available in a different specification, or at a different price

Design	Sustainability	Technology	Safety	Mercedes-EQ	Model lines	Upholstery	Model prices	Personalisation	Standard equipment	Genuine accessories	Technical data	Additional information
--------	----------------	------------	--------	-------------	-------------	------------	--------------	-----------------	--------------------	---------------------	----------------	------------------------



# EQE AMG Line Premium Plus

Standard equipment highlights



In addition to/replacement of AMG Line Premium:

#### Exterior

21" alloy wheels - multi-spoke design, aerodynamically optimised, painted black and rim flange with a high-shine finish (code RWI)

AIRMATIC air suspension

DIGITAL LIGHT

Summer tyres





Heated windscreen

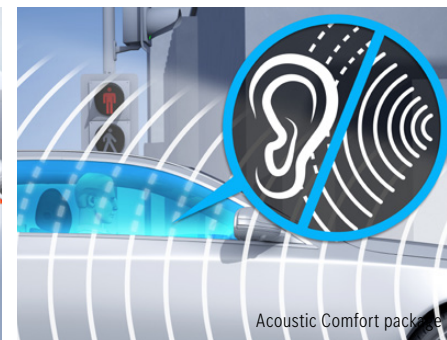

Acoustic Comfort package

**Interior**

Acoustic Comfort package

Head-up display

Heated windscreen

**Communications, Safety and Assistance Systems**

Burmester® surround sound system

Driving Assistance package Plus

MBUX augmented reality for navigation

MBUX Interior Assistant (front)

Multifunction telephony

Parking package with Parking Assist and 360° camera

URBAN GUARD Plus vehicle protection

**Trim and Upholstery**

ARTICO man-made leather/MICROCUT microfibre – black/space grey

Anthracite linestructure lime wood

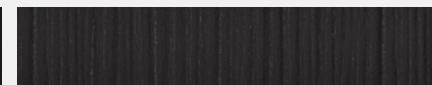
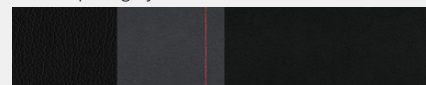



# EQE Exclusive Luxury



## The ultimate choice is exclusive and luxurious.

Character is further refined through high-gloss black painted 20" alloy wheels and the distinct Electric Art exterior and interior styling. Additional features include comfort seats and climatised front seats. You can enjoy heated rear seats, a heated windscreen, and a heated steering wheel for colder days.

**EQE Exclusive Luxury**

**OTR from £88,450<sup>1</sup>**

<sup>1</sup>The recommended on-the-road price includes the Road Fund Licence applicable to the standard model plus delivery charge (£780.00 incl. VAT), new vehicle registration fee (£55.00) and number plates (£25.00 incl. VAT). VAT is calculated at the standard rate of 20%. Some of the model features, optional extras and colours shown may not be available, or may only be available in a different specification, or at a different price

Design	Sustainability	Technology	Safety	Mercedes-EQ	Model lines	Upholstery	Model prices	Personalisation	Standard equipment	Genuine accessories	Technical data	Additional information
--------	----------------	------------	--------	-------------	-------------	------------	--------------	-----------------	--------------------	---------------------	----------------	------------------------

# EQE Exclusive Luxury

Standard equipment highlights



In addition to/replacement of AMG Line Premium Plus:

#### Exterior

20" alloy wheels – 5-twin-spoke design, aerodynamically optimised, painted high-gloss black with a high-shine finish (code 60R)

Electric Art exterior styling – front apron with chrome trim in the upper and lower sections. Rear apron painted in the vehicle colour with lower section in graphite grey metallic and chrome. Side skirts painted in graphite grey with chrome inserts

Summer tyres







### Interior

Climatised front seats

Comfort front headrests

Comfort seats

Electric Art interior styling

Heated steering wheel

Heated rear seats

### Trim and Upholstery

Nappa leather - black/space grey

Ship's deck open-pore walnut wood

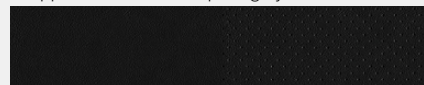

# Upholstery

● Standard   □ No-cost option   – Not available



**651A ARTICO man-made leather/MICROCUT microfibre - black/space grey**

AMG Line	●
AMG Line Premium	●
AMG Line Premium Plus	●
Exclusive Luxury	–



**801A Nappa leather<sup>1</sup> - black/space grey**

AMG Line	–
AMG Line Premium	–
AMG Line Premium Plus	–
Exclusive Luxury	●



**804A Nappa leather<sup>1</sup> - balao brown/black**

AMG Line	–
AMG Line Premium	–
AMG Line Premium Plus	–
Exclusive Luxury	□



**814A Nappa leather<sup>1</sup> - balao brown/neva grey**

AMG Line	–
AMG Line Premium	–
AMG Line Premium Plus	–
Exclusive Luxury	□

<sup>1</sup>100% of seat upholstery is pure leather



[Book a test drive](#)[Buy your EQE](#)[Find a Retailer](#)

# Model prices

Model line	Powertrain	CO <sub>2</sub> WLTP <sup>1,*</sup>	Basic RRP excl. VAT (£)	Total RRP incl. VAT (£)	Road Fund Licence (£) <sup>2</sup> WLTP	Rec. OTR price (£) <sup>3</sup> WLTP	P11D value (£)	BiK tax rate 2022/23 (%) <sup>2</sup>
<b>AMG Line</b>								
EQE 350+	Battery electric vehicle, 292hp/215 kW Electric range up to 394 miles - WLTP <sup>1</sup>	0	62,991.67	75,590.00	0.00	<b>76,450.00</b>	76,395.00	2
<b>AMG Line Premium</b>								
EQE 350+	Battery electric vehicle, 292hp/215 kW Electric range up to 382 miles - WLTP <sup>1</sup>	0	67,158.33	80,590.00	0.00	<b>81,450.00</b>	81,395.00	2
<b>AMG Line Premium Plus</b>								
EQE 350+	Battery electric vehicle, 292hp/215 kW Electric range up to 356 miles - WLTP <sup>1</sup>	0	72,991.67	87,590.00	0.00	<b>88,450.00</b>	88,395.00	2
<b>Exclusive Luxury</b>								
EQE 350+	Battery electric vehicle, 292hp/215 kW Electric range up to 378 miles - WLTP <sup>1</sup>	0	72,991.67	87,590.00	0.00	<b>88,450.00</b>	88,395.00	2

<sup>1</sup>The indicated values were determined according to the prescribed measurement method - Worldwide Harmonised Light Vehicle Test Procedure (WLTP). Figures shown may include options which are not available in the UK. Battery Electric Vehicles (BEV) require mains electricity for charging, range figures determined with the battery fully charged. <sup>2</sup>Figures shown are for comparability purposes; only compare with other cars tested to the same technical procedures. Figures may not reflect real life driving results, which will depend upon a number of factors including the starting charge of the battery, factory-fitted options, accessories fitted (post registration), variations in weather, driving styles and vehicle load. Further information about the test used to establish range, power consumption and CO<sub>2</sub> figures can be found at <http://www.mercedes-benz.co.uk/WLTP> <sup>3</sup>A different first year rate of Vehicle Excise Duty (Road Fund Licence) applies for new cars. Please refer to page 43 for the relevant rate for the second and subsequent years <sup>4</sup>The recommended on-the-road price includes the Road Fund Licence applicable to the standard model plus delivery charge (£780.00 incl. VAT), new vehicle registration fee (£55.00) and number plates (£25.00 incl. VAT). VAT is calculated at the standard rate of 20%. Some of the model features, optional extras and colours shown may not be available, or may only be available in a different specification, or at a different price

[Book a test drive](#)[Buy your EQE](#)[Find a Retailer](#)

# Colour options

● Standard

Total prices incl. VAT



040 black non-metallic



970 spectral blue metallic

£895



885 MANUFAKTUR opalite white metallic

£1,195



818 MANUFAKTUR graphite grey magno<sup>1</sup>

£2,175



197 obsidian black metallic

£895



922 high tech silver metallic

£895



956 MANUFAKTUR alpine grey solid

£1,195



831 graphite grey metallic

£895



996 MANUFAKTUR hyacinth red metallic

£1,195

<sup>1</sup>MANUFAKTUR magno matt paint finishes require extra care. Please refer to the Owner's Manual for instructions

Please note that, owing to limitations of on-screen representation, paint colours may differ from those shown

Design	Sustainability	Technology	Safety	Mercedes-EQ	Model lines	Upholstery	Model prices	Personalisation	Standard equipment	Genuine accessories	Technical data	Additional information
--------	----------------	------------	--------	-------------	-------------	------------	--------------	-----------------	--------------------	---------------------	----------------	------------------------



[Book a test drive](#)[Buy your EQE](#)[Find a Retailer](#)

# Standard equipment

● Standard    – Not available

## Battery and Charging

	AMG Line	AMG Line Premium	AMG Line Premium Plus	Exclusive Luxury
22 kW on-board charger	●	●	●	●
90 kWh battery	●	●	●	●
170 kW on-board charger	●	●	●	●
CCS-2 connector (DC charging with Combined Charging System, compatible with AC and DC)	●	●	●	●
Charging cable – Mode 3 cable (5 metres), Type 2, enables you to charge the vehicle battery via the wallbox or at public charging stations	●	●	●	●
IONITY – one year, rapid-charging with IONITY	●	●	●	●
Mercedes me Charge – three year subscription – fully integrated access to a host of public charging stations. A single contract covers all billing. One-time registration and activation as part of Mercedes me connect. Use via app, MBUX multimedia system or RFID card	●	●	●	●

## Steering, Transmission and Suspension

	AMG Line	AMG Line Premium	AMG Line Premium Plus	Exclusive Luxury
AIRMATIC air suspension struts with integrated adaptive damping system at the front and rear axle – automatic level control system, depending on load: load detection for a constant suspension level. Suspension level can be raised for rough roads and is automatically lowered at high speeds, MBUX can remember these actions and suggest them when arriving at the same location	–	–	●	●
DYNAMIC SELECT – three different drive programs, ECO, COMFORT and SPORT with the ability to save an INDIVIDUAL program, five recuperation levels: D Auto (ECO Assist, standard setting), D + (coasting), D (low recuperation), D - (medium recuperation), D - - (high recuperation)	●	●	●	●

## Exterior

	AMG Line	AMG Line Premium	AMG Line Premium Plus	Exclusive Luxury
Acoustic Comfort package	–	–	●	●
AMG exterior styling – AMG front bumper painted in vehicle colour with A-wing in high-gloss black and trim in chrome, front splitter in high-gloss chrome with flics and fins at the left and right air inlets in high-gloss black with chrome trim. AMG rear apron painted in vehicle colour with diffuser-look inserts in high-gloss black, double trim strip in chrome and flics at the left and right air outlets in grained black. Side skirts painted in high-gloss black with insert in chrome	●	●	●	–
Electric Art exterior styling – front apron with chrome trim in the upper and lower sections. Rear apron painted in the vehicle colour with lower section in graphite grey metallic and chrome. Side skirts painted in graphite grey with chrome inserts	–	–	–	●
Headlamps – DIGITAL LIGHT	–	–	●	●
Headlamps – static LED headlamps with Highbeam Assist	●	●	–	–
Heated windscreen washer system	●	●	●	●
Mirror package – electrically folding exterior mirrors, automatically dimming interior and exterior driver mirror, surround lighting in both outside mirrors with brand logo projection to illuminate the entrance area	●	●	●	●
Panoramic sliding sunroof	●	●	●	●
Privacy glass	●	●	●	●



# Standard equipment

● Standard – Not available

## Wheels

	AMG Line	AMG Line Premium	AMG Line Premium Plus	Exclusive Luxury
19" AMG alloy wheels – 5-twin-spoke design, aerodynamically optimised, painted black with a high-sheen finish, 255/45 R19 tyres (code RRH)	●	–	–	–
20" AMG alloy wheels – 5-spoke design, painted metallic vanadium silver with aero elements in matt tantalite grey, 255/40 (front) and 285/35 (rear) R 20 tyres (code RRM)	–	●	–	–
21" alloy wheels – multi-spoke design, aerodynamically optimised, painted black and rim flange with a high-sheen finish, 255/35 (front) and 285/30 (rear) tyres R21 (code RWI)	–	–	●	–
20" alloy wheels – 5-twin-spoke design, aerodynamically optimised, painted high-gloss black with a high-sheen finish, 255/40 R20 tyres (code 81R)	–	–	–	●
Summer tyres	●	●	●	●

## Interior

Air Quality package – infrared quality sensor plus a fine particle sensor on outside and inside includes Course, HEPA fine particle and Broad spectrum filter against fine particles (PM2.5), pollen, nitrogen dioxides (NOx), sulphur dioxides (SO2) and certain viruses. Antibacterial effect reduces the growth of fungi and bacteria on the interior air filter. Automatic switching between air recirculation or fresh air depending on the measured air quality. Air quality menu in the MBUX multimedia system	●	●	●	●
Ambient lighting – three dimming zones (all, ambient and accent), variable brightness setting, 64 colours and ten colour moods	●	–	–	–
Ambient Lighting Plus – 64 colours, all colours can be selected individually, ambient lighting (code 891) with indirect illumination, pre-programmed colour schemes which illuminate defined areas of the interior in different colours, contour lighting of the seats, dynamic mode: the colours alternate slowly, emotively appealing animations: welcome display or feedback in colour when adjusting the air conditioning	–	●	●	●
AMG interior styling – AMG sports steering wheel, AMG pedals, AMG door sills with AMG illuminated lettering and AMG velour floor mats	●	●	●	–
Black velour floor mats	–	–	–	●

	AMG Line	AMG Line Premium	AMG Line Premium Plus	Exclusive Luxury
Electric Art interior styling	–	–	–	●
Interior Light package	●	●	●	●
KEYLESS-GO	–	●	●	●
Memory package – electrical adjustment and memory function for front seats, steering wheel, outside mirror, heated areas of the seat cushion and seat backrest, head-up display (where fitted), four-way front lumbar support and seat cushion length. Includes PRE-SAFE® positioning function for front passenger seat	–	●	●	●
Seats – climatised (front)	–	–	–	●
Seats – comfort seats with comfort front headrests	–	–	–	●
Seats – heated (front)	●	●	●	–
Seats – heated (rear)	–	–	–	●
Seats – split fold rear seats	●	●	●	●
Steering wheel – heated	–	–	–	●
Storage compartment under center console	●	●	●	●
THERMATIC automatic climate control with two climate zones	●	–	–	–
THERMOTRONIC automatic climate control with four climate zones	–	●	●	●
Windscreen – heated	–	–	●	●

## Paint, Trim and Upholstery

Dashboard in leather look	●	●	●	●
Paint – non-metallic	●	●	●	●
Trim – lower trim – black fine structure	●	●	●	●

<sup>1</sup>Free of charge for three years from activation

<sup>2</sup>Compatible smartphone required. For further details please visit <https://www.mercedes-benz-mobile.com/>



[Book a test drive](#)[Buy your EQE](#)[Find a Retailer](#)

# Standard equipment

● Standard    – Not available

## Paint, Trim and Upholstery (continued)

	AMG Line	AMG Line Premium	AMG Line Premium Plus	Exclusive Luxury
Trim – main trim – anthracite linestructure lime wood	●	●	●	–
Trim – main trim – ship's deck open-pore walnut wood	–	–	–	●
Roof lining – black fabric	●	●	●	–
Roof lining – grey fabric	–	–	–	●
Upholstery – ARTICO man-made leather/MICROCUT microfibre	●	●	●	–
Upholstery – nappa leather	–	–	–	●

## Safety and Assistance Systems

	AMG Line	AMG Line Premium	AMG Line Premium Plus	Exclusive Luxury
Active Traffic Sign Assist	●	●	●	●
Driving Assistance package	–	●	–	–
Driving Assistance package Plus	–	–	●	●
EASY-PACK tailgate	●	●	●	●
Mercedes-Benz emergency call system	●	●	●	●
Parking package with Parking Assist and reversing camera	●	●	–	–
Parking package with Parking Assist and 360° camera	–	–	●	●
Tirefit	●	●	●	●
URBAN GUARD vehicle protection	●	●	–	–
URBAN GUARD Plus with anti-theft protection hardware including alarm and immobilizer. Theft notification and park damage detection <sup>1</sup> , stolen vehicle locator <sup>1</sup> , 360° surroundview-camera snapshots <sup>1</sup> and remote key immobilizer <sup>1</sup>	–	–	●	●

## Communications and In-Car Entertainment

	AMG Line	AMG Line Premium	AMG Line Premium Plus	Exclusive Luxury
12.3-inch digital instrument cluster display	●	●	●	●
12.8-inch media display	●	●	●	●
Digital radio	●	●	●	●
EQ navigation services – navigation optimised for Mercedes-EQ, range on map (range display), display of charging stations (info on availability, programming of charging settings and Pre-Entry Climate Control incl. remote retrieval of charging status and range	●	●	●	●
Fingerprint scanner – colour-illuminated fingerprint scanner in the trim strip below the OLED media display, two fingerprints per user can be stored, quick access replaces PIN entry, protects personal data such as profiles plus office and payment functions	●	●	●	●
Hard-disc navigation	●	●	●	●
Head-up display	–	–	●	●
Live traffic information – 3 years	●	●	●	●
MBUX augmented reality for navigation	–	–	●	●
Pre-entry climate control	●	●	●	●
Pre-installation for Car Sharing	●	●	●	●
Sound system – Burmester® surround sound system	–	–	●	●
Sound system – Mercedes-Benz sound system	●	●	–	–
USB package – six fast charging USB-C ports including four compatible for data transfer	●	●	●	●
Wireless smartphone integration (front) <sup>2</sup>	●	●	●	●

<sup>1</sup>Free of charge for three years from activation

<sup>2</sup>Compatible smartphone required. For further details please visit <https://www.mercedes-benz-mobile.com/>

[Book a test drive](#)[Buy your EQ](#)[Find a Retailer](#)

# Standard equipment

● Standard    – Not available

## Services

	AMG Line	AMG Line Premium	AMG Line Premium Plus	Exclusive Luxury
Geofencing – available to use free of charge for three years following activation <sup>1</sup> , denotes a specific area and notifies via push message when the vehicle leaves or enters this area	●	●	●	●
Parked vehicle locator – available to use free of charge for three years following activation <sup>1</sup> , shows the position of the parked vehicle in a radius of approx. 1.5 km	●	●	●	●
Personalisation – available to use free of charge for three years following activation <sup>1</sup> , stores settings such as the radio station or navigation destination in the personal driver profile and enables these to be used in vehicles with the same telematics generation, the profile can be linked to the key, and the functions can therefore already be activated before getting in	●	●	●	●
Programming of auxiliary heater/ventilation	●	●	●	●
Remote door locking and unlocking – available to use free of charge for three years following activation <sup>1</sup> , provides convenient remote monitoring	●	●	●	●
Remote retrieval of vehicle status <sup>1</sup> – shows mileage, tyre pressure, washer fluid level, etc.	●	●	●	●
Remote vehicle finder – available to use free of charge for three years following activation <sup>1</sup> indicators activated via the app help to draw attention to the vehicle, for example in large, confusing car parks	●	●	●	●
Sliding sunroof/windows with remote closing and opening including ventilation function to use free of charge for three years following activation <sup>1</sup> for a breath of fresh air in the vehicle available	●	●	●	●
Send2Car function – available to use free of charge for three years following activation <sup>1</sup> , sends selected addresses via the app to the vehicle's navigation system, for example POIs or restaurants	●	●	●	●
Speedfencing	●	●	●	●

Stolen Vehicle Help (free of charge for 3 years from activation) – this service reduces the bureaucratic effort required and gives you an advantage in terms of time. In the event of theft, you can report it to the police. You can transfer the police file number (depending on country) plus the relevant vehicle and owner information quite simply via app to our certified partner's security centre. This centre will then coordinate with the local police station to track your vehicle

Valet protect – available to use free of charge for 3 years following activation<sup>1</sup> notifies via the app when the ignition is switched on/off and when the vehicle moves outside a defined radius (1 km, 2.5 km or 5 km)

Vehicle Tracking

	AMG Line	AMG Line Premium	AMG Line Premium Plus	Exclusive Luxury
Stolen Vehicle Help (free of charge for 3 years from activation) – this service reduces the bureaucratic effort required and gives you an advantage in terms of time. In the event of theft, you can report it to the police. You can transfer the police file number (depending on country) plus the relevant vehicle and owner information quite simply via app to our certified partner's security centre. This centre will then coordinate with the local police station to track your vehicle	●	●	●	●
Valet protect – available to use free of charge for 3 years following activation <sup>1</sup> notifies via the app when the ignition is switched on/off and when the vehicle moves outside a defined radius (1 km, 2.5 km or 5 km)	●	●	●	●
Vehicle Tracking	●	●	●	●

<sup>1</sup>To use this service, you must register on the Mercedes me portal and also accept the Terms of Use for the Mercedes me connect services. In addition, the respective vehicle must be paired with the user account. Upon expiry of the initial term, the services can be extended for a fee. Initial activation of the services is possible within 1 year of first registration or commissioning by the customer, whichever occurs first

# Genuine accessories

We've developed a range of accessories you can add to help personalise and enhance your EQE.

## Rear-mounted bicycle rack, for trailer coupling, folding, 2 bicycles

Easy-to-use, lockable rear bicycle rack, designed to provide secure transport for up to 2 bikes. Extremely simple to fit to the trailer hitch. Securing your bikes on the rack is equally simple. Maximum load capacity of up to 30 kg per rail, making rack suitable for most ebikes. An ingenious roller mechanism means that the boot can still be opened. The rack is easy to fold for space-saving stowage in the boot, at your holiday accommodation or at home. (A0008901700)



## DUO plus child seat, with ISOFIX

Mercedes-Benz 'DUO PLUS', suitable for children between the ages of around 9 months to 4 years (9-18 kg). Featuring ISOFIX attachments to make securely fitting the child seat even easier. The TopTether also offers additional safety. The height-adjustable shoulder belt and three seat positions offer additional comfort. The cover with an exclusive design can be removed and washed. This has been tested to Mercedes-Benz requirements. (A0009704302)



## Rear-mounted bicycle rack, for trailer coupling, folding, 3 bicycles

Easy-to-use, lockable rear bicycle rack, designed to provide secure transport for up to 3 bikes. Extremely simple to fit to the trailer coupling. Securing your bikes on the rack is equally simple. Maximum load capacity of up to 30 kg per bicycle rail. The rack is therefore suitable for most e-bikes. An ingenious roller mechanism means that the boot can still be opened. The rack is easy to fold for space-saving stowage in the boot, in your holiday apartment or at home. (A0008901800)



## Coolbox

Be it cool drinks, a picnic or baby food: the thermoelectric refrigerator box cools upon request and is the perfect companion on any day out. It fits perfectly into every Mercedes-Benz vehicle and holds 13 litres. The portable refrigerator box is made up of a textile coating with fitted pockets and a zip. The inside, fixed plastic container is easy to clean. (A0008205409)

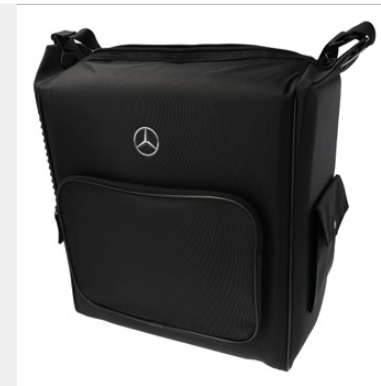

All the above accessories are subject to availability and compatibility. Please ask your Mercedes-Benz Retailer for more information Images shown are for illustration purposes only

Design	Sustainability	Technology	Safety	Mercedes-EQ	Model lines	Upholstery	Model prices	Personalisation	Standard equipment	Genuine accessories	Technical data	Additional information
--------	----------------	------------	--------	-------------	-------------	------------	--------------	-----------------	--------------------	---------------------	----------------	------------------------



[Book a test drive](#)[Buy your EQE](#)[Find a Retailer](#)

# Technical data

- Standard

Model	EQE 350+	
<b>Motor</b>		
Battery type	lithium-ion high-voltage	
Electric motor type	asynchronous	
Battery capacity	kWh	90
Power <sup>1</sup>	hp (kW)	292 (215)
Torque <sup>1</sup>	Nm at rpm	565/3,559
On-board charger	22 kW AC; 170 kW DC	
Emissions standard	EU6	

Transmission	
Single-speed automatic	●

Performance		
Acceleration 0–62 mph	sec	6.4
Top speed	mph	130
Charging time		
Charging speed AC fast charge – 22kW		
80% charging time on AC 22kW charging <sup>3,4</sup>		4 hrs 15 mins
Charging speed DC rapid – 170kW		
10–80% charging time on DC rapid charging <sup>3,4</sup>		32 mins
Range power consumption combined <sup>4,5</sup>	Wh/km	183–171
Electric range – WLTP <sup>4</sup>	miles	356–394

Model	EQE 350+	
<b>Weights and capacities</b>		
Kerb weight <sup>5</sup>	kg	2,355
Perm. Gross Vehicle Weight	kg	2,880
Boot capacity – seats up/down	l	430/895
Towing capacity – unbraked/braked	kg	750/750
Turning circle	m	12.5

Insurance	
All variants	tba

Insurance ratings may vary depending on model line and specification. Please refer to <http://www.thatcham.org/abigrouprating/> for further details

<sup>1</sup>Figures according to Regulation (EC) No. 595/2009 in the currently applicable version <sup>2</sup>Specified voltage and current values refer to network infrastructure and can be limited by the vehicle. Times are from 10-100% charge using a wallbox (three-phase) or standard socket (single-phase) <sup>3</sup>If you are planning to charge your Mercedes-Benz plug-in electric vehicle using a 3-pin domestic plug socket you must get a qualified electrician to inspect and sign off the socket to confirm it is safe and suitable to charge your vehicle. Do not use an electric vehicle 3-pin charge cable with an extension cord <sup>4</sup>Figures shown are for comparability purposes; only compare with other cars tested to the same technical procedures. Figures may not reflect real life driving results, which will depend upon a number of factors including the starting charge of the battery, factory-fitted options, accessories fitted (post registration), variations in weather, driving styles and vehicle load. Further information about the test used to establish range, power consumption and CO<sub>2</sub> figures can be found at <http://www.mercedes-benz.co.uk/WLTP> <sup>5</sup>Specified voltage and current values refer to network infrastructure and can be limited by the vehicle. Times are from 10-80% charge using public rapid charging at 100 kW <sup>6</sup>Mass of the vehicle in running order with at least 90% full fuel tank, plus the mass of the driver (estimated by law at 75 kg), fuel and fluids, equipped with the standard equipment as specified by the manufacturer as well as, where applicable, the mass of the body, cab, trailer coupling and spare wheel(s) as well as tools. Optional extras, additional equipment and accessories can influence the weight, residual payload, rolling resistance, aerodynamics, etc., and therefore also affect the consumption/CO<sub>2</sub> values

[Book a test drive](#)[Buy your EQE](#)[Find a Retailer](#)

# Electric range and consumption

Model	Energy Consumption – combined (Wh/km) <sup>1,2</sup>	All Electric Range (km)	All Electric Range (miles) <sup>2</sup>
EQE 350+ AMG Line	tba	635	394
EQE 350+ AMG Line Premium	171	615	382
EQE 350+ AMG Line Premium Plus	183	573	356
EQE 350+ Exclusive Luxury	tba	609	378

<sup>1</sup>Specified voltage and current values refer to network infrastructure and can be limited by the vehicle. Times are from 10-80% charge using public rapid charging at 100 kW. <sup>2</sup>Figures shown are for comparability purposes; only compare with other cars tested to the same technical procedures. Figures may not reflect real life driving results, which will depend upon a number of factors including the starting charge of the battery, factory-fitted options, accessories fitted (post registration), variations in weather, driving styles and vehicle load. Further information about the test used to establish range, power consumption and CO<sub>2</sub> figures can be found at <http://www.mercedes-benz.co.uk/WLTP>

[Book a test drive](#)[Buy your EQE](#)[Find a Retailer](#)

# EQE

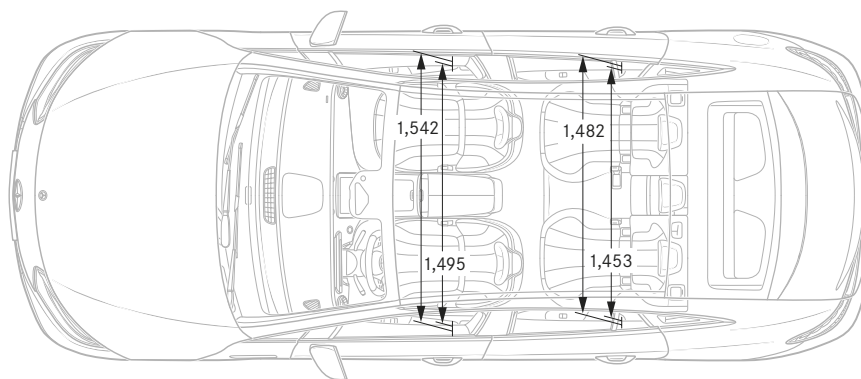
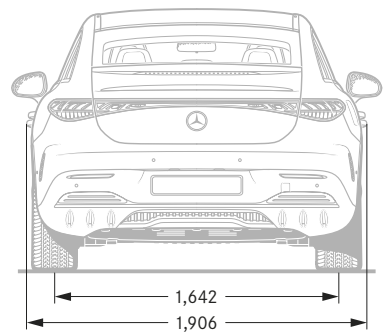
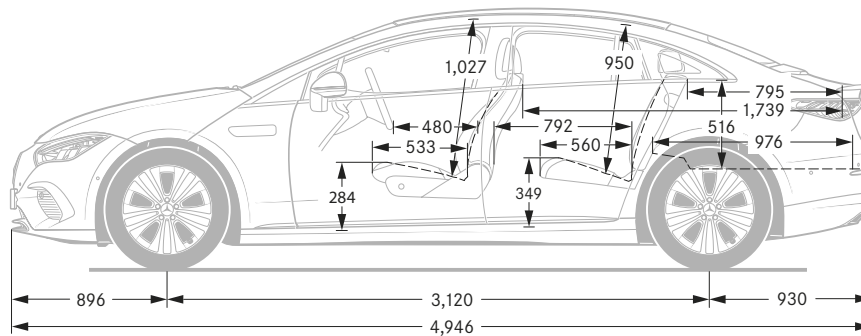
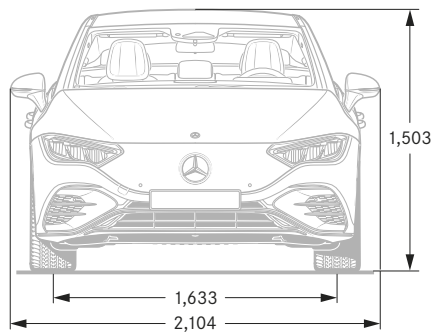

All measurements in millimetres. The dimensions shown are mean values and apply to standard-specification, unladen vehicles. Dimensions may vary slightly depending on the engine. Please consult your Retailer for further information

Design	Sustainability	Technology	Safety	Mercedes-EQ	Model lines	Upholstery	Model prices	Personalisation	Standard equipment	Genuine accessories	Technical data	Additional information
--------	----------------	------------	--------	-------------	-------------	------------	--------------	-----------------	--------------------	---------------------	----------------	------------------------



[Book a test drive](#)[Buy your EQE](#)[Find a Retailer](#)

# Road Fund Licence

All road vehicle registrations are subject to Vehicle Excise Duty (Road Fund Licence), which varies in accordance with the vehicle's CO<sub>2</sub> emissions. A first year rate for each taxation band will apply. The table below shows the bands (A–M) created by the DVLA and the corresponding Road Fund Licence. CO<sub>2</sub> emissions and the relevant Excise Duty are shown on the model pricing page.

Band	CO <sub>2</sub> emissions (g/km)	First year rate petrol and RDE2 diesel (£)	First year rate all other diesel (£) <sup>1</sup>	First year rate alternative fuel (£)	Electric vehicles		Alternative fuel vehicles		Petrol/diesel vehicles	
					Standard rate (£)	Premium rate (£) <sup>2</sup>	Standard rate (£)	Premium rate (£) <sup>2</sup>	Standard rate (£)	Premium rate (£) <sup>2</sup>
A	0	0.00	0.00	0.00	0.00	0.00	0.00	0.00	0.00	0.00
B	1 to 50	10.00	25.00	0.00	0.00	0.00	155.00	510.00	165.00	520.00
C	51 to 75	25.00	120.00	15.00	0.00	0.00	155.00	510.00	165.00	520.00
D	76 to 90	120.00	150.00	110.00	0.00	0.00	155.00	510.00	165.00	520.00
E	91 to 100	150.00	170.00	140.00	0.00	0.00	155.00	510.00	165.00	520.00
F	101 to 110	170.00	190.00	160.00	0.00	0.00	155.00	510.00	165.00	520.00
G	111 to 130	190.00	230.00	180.00	0.00	0.00	155.00	510.00	165.00	520.00
H	131 to 150	230.00	585.00	220.00	0.00	0.00	155.00	510.00	165.00	520.00
I	151 to 170	585.00	945.00	575.00	0.00	0.00	155.00	510.00	165.00	520.00
J	171 to 190	945.00	1,420.00	935.00	0.00	0.00	155.00	510.00	165.00	520.00
K	191 to 225	1,420.00	2,015.00	1,410.00	0.00	0.00	155.00	510.00	165.00	520.00
L	226 to 255	2,015.00	2,365.00	2,005.00	0.00	0.00	155.00	510.00	165.00	520.00
M	over 255	2,365.00	2,365.00	2,355.00	0.00	0.00	155.00	510.00	165.00	520.00

Some of the model features, optional extras and colours shown may not be available, or may only be available in a different specification, or at a different price.

<sup>1</sup>Applies to all Mercedes-Benz diesel models which do not comply with RDE (Real Driving Emissions) Step 2 Certified (Euro 6d)

<sup>2</sup>Premium rate only applicable to vehicles where the list price is over £40,000 including any factory-fitted options, standard UK delivery charge and VAT

Design	Sustainability	Technology	Safety	Mercedes-EQ	Model lines	Upholstery	Model prices	Personalisation	Standard equipment	Genuine accessories	Technical data	Additional information
--------	----------------	------------	--------	-------------	-------------	------------	--------------	-----------------	--------------------	---------------------	----------------	------------------------

# Services and insurance

## Mercedes-Benz ServiceCare

We believe that servicing costs should be as flexible and affordable as possible for your EQE, which is why we offer ServiceCare, an easy way to budget for all your servicing costs. It spreads your bills into manageable payments based on whether you have a new or used Mercedes-Benz.

With ServiceCare we guarantee the price of parts and labour for up to four services and safeguard against any further inflation.

You can choose either to add your servicing costs into your monthly spend or pay the full amount in a one-off payment, giving you peace of mind that they are taken care of for the period of the plan.

[Click here for more information](#)

## Warranty and breakdown cover

Every Mercedes-Benz comes with a three-year unlimited mileage warranty against manufacturing or material defects<sup>1</sup> and up to 30 years warranty against perforation due to corrosion from the inside out.<sup>2</sup> What's more, it's also covered by Mercedes-Benz Roadside Assistance – a unique package comprising up to 30 years pan-European breakdown assistance.<sup>2</sup>

## Battery Warranty

The battery comes with a 10-year 155,000-mile warranty.

## Motor Insurance

We know that once you have chosen your Mercedes-Benz you can't wait to drive it – that's why we created First Cover<sup>3</sup>. It gives you 7 days' free comprehensive Motor Insurance when you buy a new or used vehicle from a Mercedes-Benz Retailer. We will also send you a quote for annual cover, so you can enjoy the same peace of mind all year round.

[Apply for First Cover](#)

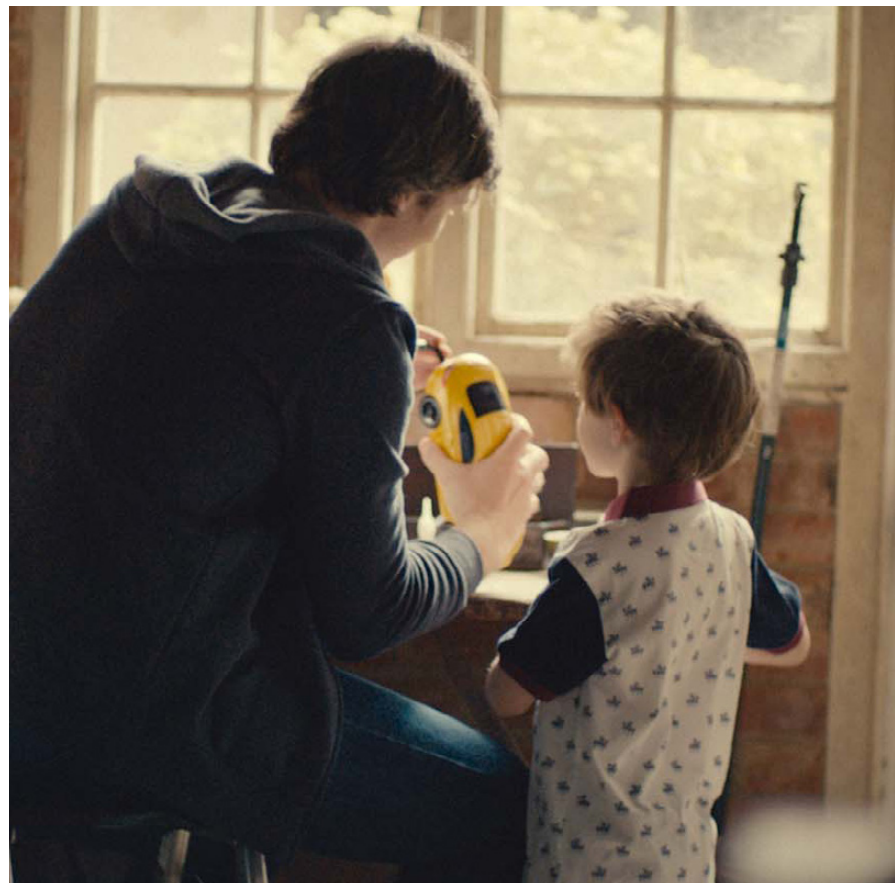

<sup>1</sup>Applies to vehicles sold by Mercedes-Benz in the UK to its franchised Retailers

<sup>2</sup>Subject to full Terms and Conditions, dependent on date of registration, available upon request

<sup>3</sup>Terms and Conditions apply. We are an independent intermediary dealing with selected insurers in respect of annual insurance





Effective from March 2022 Production. Information correct at time of publication 01.04.2022.  
Prices and specifications are subject to change without prior notice.  
MBV295PL/0422

