

# RENAULT MASTER



March 2022



## Renault Master, a vehicle for everyone

Renault presents Renault Master and reasserts its expertise in the field. Master is instantly distinguished through a more dynamic front-end design featuring the signature C-shaped lighting. An elevated bonnet line, vertical front grille and new 'Urban Grey' colour complete the revised styling. Master is available in three body heights and four body lengths to adapt to the needs of all users.



## Driving has never been as comfortable

Professionals have tough and busy days; this is why the Renault Master cabin area has been designed to provide the comfort and practicality of a 'Mobile Office'. Packed with clever solutions, such as hidden laptop storage, that help to keep you connected on the go. (standard on Business+).





## Easy and secure loading

Master gives priority to practicality and efficiency. The rear doors can be opened 270° (optional), and the very low body sill makes it easier to load cumbersome items. Anchorage points (up to 12) secure the goods, and handles, ideally placed on the sides of the doors, save you effort in loading and unloading from the rear area. With its wide rear and side openings and optimum load volume (from 8 m<sup>3</sup> to 20 m<sup>3</sup>), Master adapts to the needs of all users.

In terms of security, the reinforced locks, factory fit alarm\* (Thatcham approved category 1, volumetric and perimeter) and 3-button key (standard on Business+) ensure that you work with complete peace of mind.

\*Alarm not standard on Master E-Tech electric





## Our profession, adapting to yours

Master is the tailor-made utility vehicle! A wide-range of body styles are available and include specific versions that meet unique needs: tippers (including the Aluminium Body version) and box vans. These variants are 100% Renault 'off-the-shelf' products produced and delivered as quickly as our standard vehicles.

It is also easy to convert a more bespoke vehicle using either a panel van, chassis (single or double cab) or platform cab with thanks to one of our many Renault approved converters across the UK.

For more details about our range of Off-the-shelf and Tailor Made accredited conversions please see our separate Conversions Range brochure.







1.

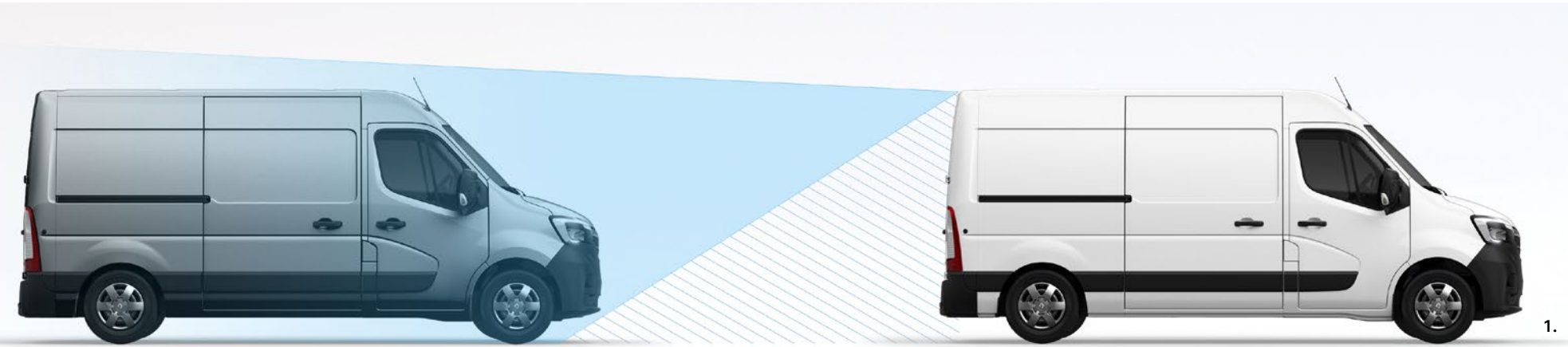

1.

## Performance and safety

In terms of driving, the increased power and torque offer greater comfort at low engine speed and more responsiveness at higher speed. The Renault Master engines help you save fuel through controlled consumption.

**Rear View Assist Camera:** The new driving assistance systems do everything to make your life easier. The "Rear View Assist", a Renault innovation, offers excellent rear view at mid and long distance for the best possible anticipation when driving\*.

**Blind Spot Warning:** Master can be fitted with a system that detects the presence of any vehicle in your blind spot. Active between 19 mph and 87 mph, a light signal alerts you immediately in the event of an obstacle and gives you an optimised side view.

**Side Wind Assist:** Master is fitted with a system that helps maintain its trajectory above 43 mph when it is subjected to strong side winds or when a vehicle is overtaking it.

**Automatic Emergency Braking System:** An active safety system able to detect moving or stationary vehicles. Automatic emergency braking is triggered and takes charge of braking if you react with a delay.

(1) Rear View Assist Camera (optional)

(2) Blind spot warning (optional)

(3) Side wind assist (standard)

(4) Advanced Emergency Braking System (optional)

\* Only when driving forward, does not function when vehicle is reversing.

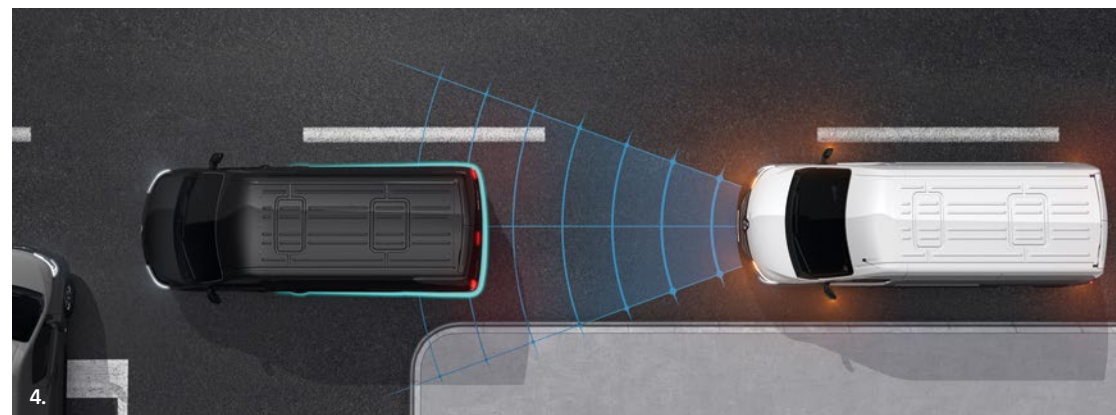
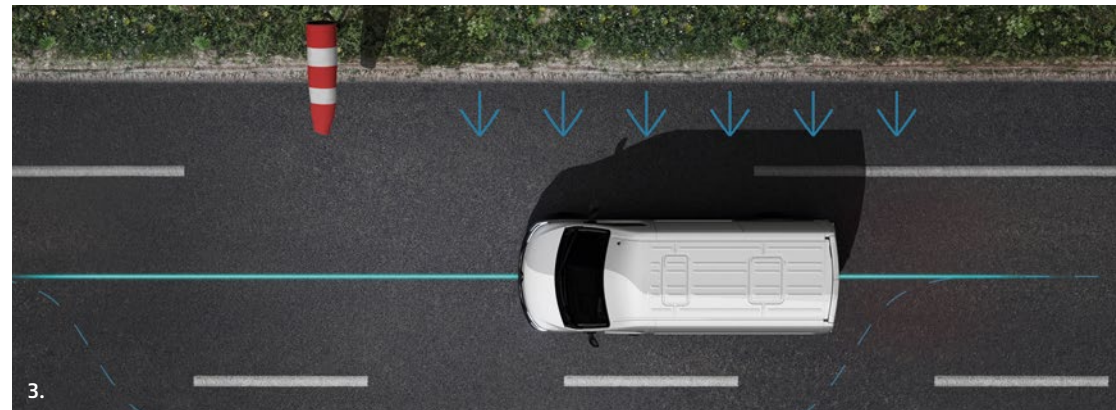
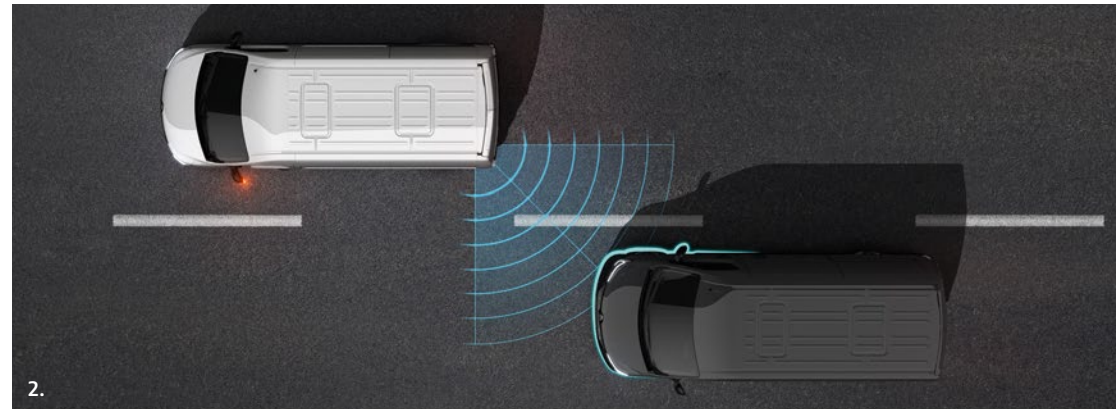



## Keeping you connected

Stay connected thanks to Master's multimedia systems and Renault Easy Connect services. MediaNav Evolution (Optional) has smartphone integration so you can use your favourite applications on the 7" touchscreen on the dashboard. You also have the R&Go application linking your smartphone or tablet to your vehicle allowing you to control your entire multimedia universe.

**1. With MediaNav Evolution, all the multimedia essentials are at your fingertips.** The new offering has Apple CarPlay™ and Android Auto™ smartphone integration, providing easy access to your applications. On-board touchscreen tablet which gives you access to features such as: navigation with traffic info, hands-free voice calls, digital radio, music streaming, etc.

**2. R&Go, integrate your smartphone or your tablet** Listen to your music, manage your contacts, navigate accurately, view fuel consumption data... with the R&Go application, it couldn't be easier, all you need to do is place your smartphone or tablet on the holder and follow the instructions.

Android Auto™ is a trademark of Google Inc.

Apple CarPlay™ is a trademark of Apple Inc.

For compatible devices, please refer to <https://www.renault.co.uk/services/multimedia/bluetooth-compatibility.html>

Connecting a mobile phone to use Bluetooth® should only be done when the vehicle is parked safely. Use of the system should always be in accordance with the rules of The Highway Code. Drivers should only use the system when it is safe to do so. Drivers should be aware of the potential for hands-free technology to distract attention from the road, which could impact on having full control of the vehicle



Front-wheel drive

## Two versions available

Does your business involve the transport of heavy, cumbersome and fragile loads? Master has two technical choices to meet your requirements: a front-wheel drive version and a rear-wheel drive version. Which to choose? Each offers unrivalled road handling and has its own advantages. With a loading sill that is 13 mm lower, Master front-wheel drive\* and its 3 different lengths is perfect for payload and road transport. But if you're looking for traction as a priority, choose Master rear-wheel drive, capable of transporting the heaviest loads on the rear axle (in particular with twin wheels) and towing a trailer up to 3.5 t\*\*, on all types of terrain. After all, what better than to have a choice?

\* GVW up to 3.5t.

\*\* Twin wheel rear-wheel drive chassis version.

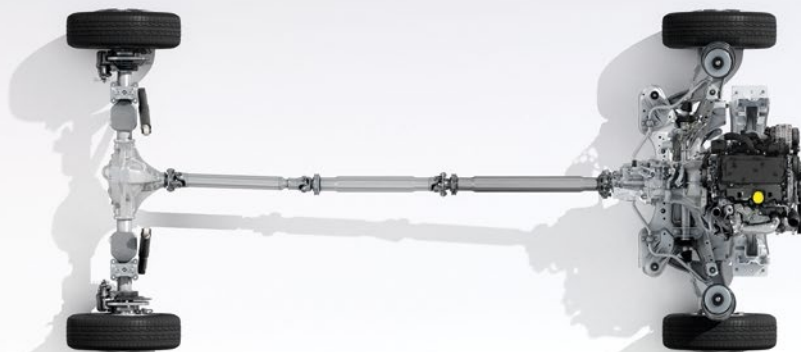

Rear-wheel drive





# Drive anywhere, in all weather

Do you drive all the time on different types of terrain and sometimes on bad roads? To meet occasional demands for enhanced traction and help you deal with poor driving conditions, Renault has developed new technology: Grip Xtend is the technology for you. Renault has developed this to improve the adaptability of your utility vehicle on difficult roads, such as unpaved or muddy tracks. The onboard computer recovers data from the wheels to optimise the vehicle's performance. When grip is lost, it adapts engine power to each wheel to improve the grip and manoeuvrability of the vehicle.

Master 4x4 (developed with Oberaigner) is there to help you. Thanks to the four-wheel drive system, its raised ground clearance and differential locking, slippery surfaces, rough roads, damp and steep slopes will no longer prevent you from working. In 2-wheel drive mode, it has an automatic rear differential lock which can be activated. It can also be activated in full 4-wheel drive mode with a front differential lock. The Master 4x4 suspension is raised by: 65 mm at the front/45 mm at the rear (twin wheels)/58 mm at the rear (single wheels). Master 4x4 also includes metal plate protection under the engine and under the body to protect vital components\*.

\* Optional on RWD versions

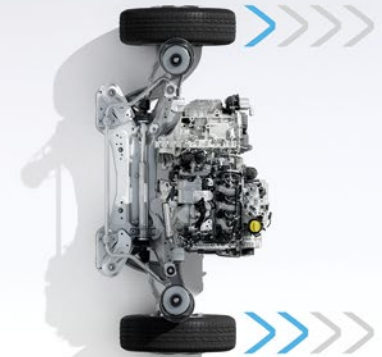

Grip Xtend

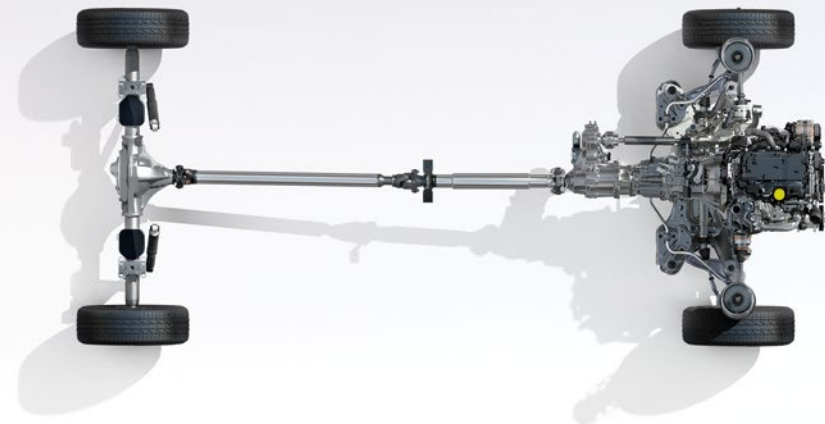

4x4 Oberaigner





## Cutting emissions and your costs

Master E-Tech electric has ultra low running costs, zero emissions whilst driving and a 75 mile (WLTP<sup>\*\*\*</sup>) range. This gives a real-world driving range of 75 miles in summer and 50 miles in winter. All that while maintaining the same dimensions as its diesel equivalents! The Master E-Tech electric has an impressive load capacity of up to 19m<sup>3</sup><sup>^</sup> and a payload that goes up to 1,425kg, plus all the extra benefits of owning an electric vehicle. Reduced road noise, no congestion charges\* and low running costs from less than 7p per mile<sup>\*\*</sup> all prove that our Master E-Tech electric will not only be a great purchase for your fleet but also for your pocket!

\*Emission based congestion charges in ULEZ's including London Congestion Charge as of 2020. \*\*Less than 7p per mile calculated by full recharge of 33kWh battery based on 6 hours of 14.4p per kWh (Source: UK Power) giving £4.75 full recharge cost divided by the real world summer range in miles. \*\*\*WLTP figures shown are for comparability purposes; only compare figures with vehicles tested to the same technical procedures. The WLTP electric range shown has been achieved using the new (WLTP) test procedure. Figures obtained after the battery was fully charged. Actual real world driving results may vary depending on factors such as the starting charge of the battery, accessories fitted after registration, weather conditions, driving styles and vehicle load. Renault estimates average real world driving figures for this vehicle as 75 miles in summer and 50 miles in winter, depending on the factors above. ^ Load volume dependent on conversion



# Renault E-Tech electric

## Always a step ahead

Renault has been pushing the boundaries of innovation from revealing the E-Tech electric concept car in 2008, and since then has been a leader in electric vehicle manufacture in Europe. It has been a priority to fulfil our commitment and continue to develop our technology so that our vehicles stay at the forefront of the electric vehicle market. In 2018, we launched our Master E-Tech electric to bring you the same large van but CO<sub>2</sub> free! The ideal workhorse for emissions-free access to city centers.

## First place on the track - first choice on the road

Our commitment to electric motoring innovation runs deeply in Renault's brand DNA. We were a founding partner in Formula E™, the FIA's newest race series. Winning the team championship in 2014/15 and 2015/16 seasons, along with the driver's championship in 2015/16, proves superior electric technology on the track and as one of Europe's best selling EV brands on the road.

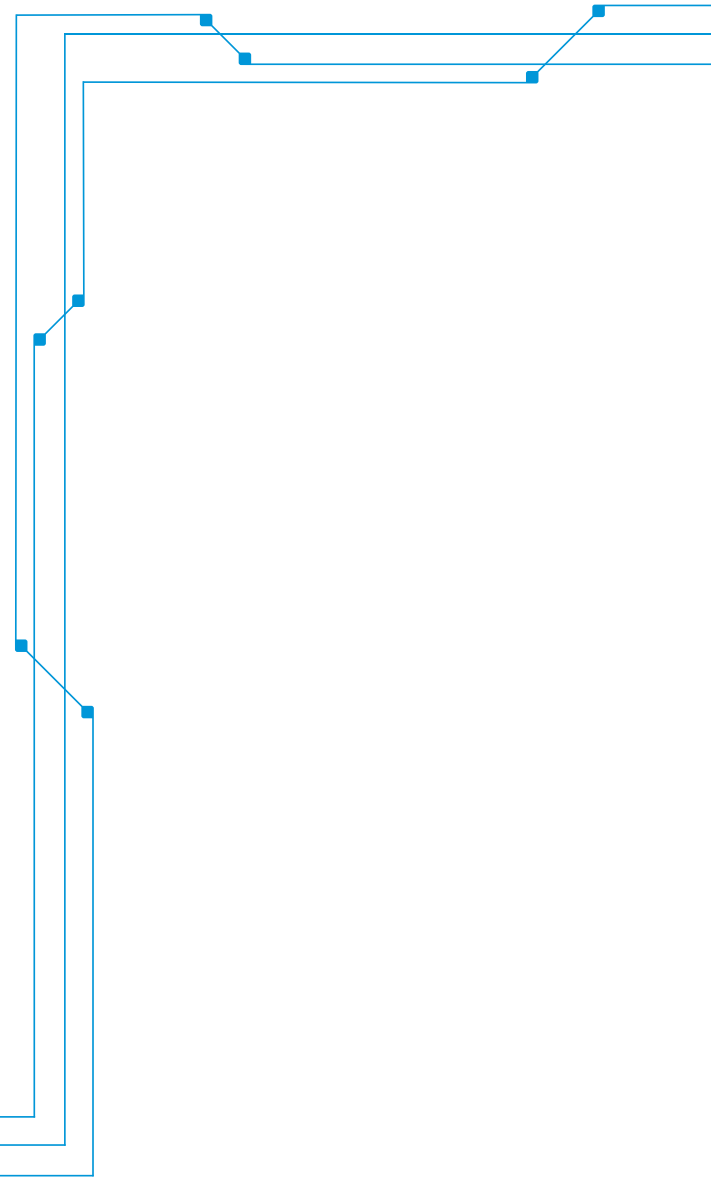

## Easy Electric Life

Electric mobility does not have to be more complicated than fuel-powered vehicles.

Far from it, electric power comes as second nature in most areas of our lives - have you ever thought about filling up your smartphone with fuel? Your van does not need to be any different from your phone, simply put it on charge.

## Renault PRO+ Electric Vans

Electric isn't just the future, it's right now. That's why our customers have been driving electric vehicles since 2011, and we've since developed the largest model range of electric LCVs in the UK. For you and your business, the result is key. So you'll be pleased to hear that with a Renault PRO+ electric van, you could make significant savings compared to running a diesel or petrol van. Plus, with over 35,000 charging points in the UK, isn't it time for you to join the electric revolution?

## It's in our nature

Through supplying the Eden Project in Cornwall with a fleet of 3 Zoe, 13 Kangoo E-Tech electric and 4 Twizy, we are supporting them in their mission to connect people with each other and the living world, exploring how we can work together towards a better future.

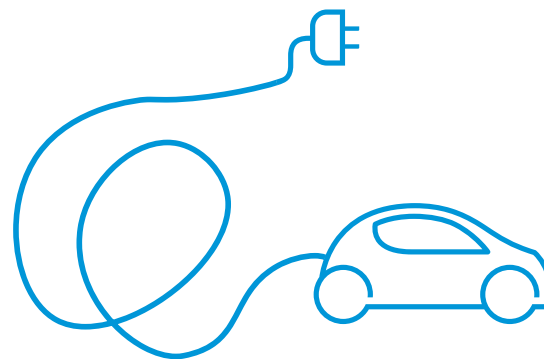



## Your 100% controlled driving range

Master E-Tech electric has 75 miles<sup>(1)</sup> of driving range in actual use thanks to its lithium-ion E-Tech electric 33 (33 kWh) battery. The 57 kW power unit offers a torque of 225 Nm and optimum driving comfort. A range of on-board technologies, such as regenerative braking (the battery recharges when the accelerator pedal is released or when the brake pedal is pressed) or the Eco mode (less abrupt acceleration and maximum speed of 50 mph), help optimise your driving range. You can charge your Master E-Tech electric in just 6 hours with a 32 A/7 kW Wallbox. The recharging flap located on the right-hand side of the vehicle, is easily accessible.



(1) Real-world driving range greater than 50 miles including the most severe use (high load, city centre driving with frequent stops and winter conditions). Actual consumption also depends on the equipment, the driving style of the driver and the elevation profile of the route.



**1. Regenerative braking.** The battery recharges when you take your foot off the accelerator or when you press on the brake pedal.

**2. Low consumption tyres.** Their low rolling resistance contributes to conserving your driving range without degrading your road-holding or braking ability.

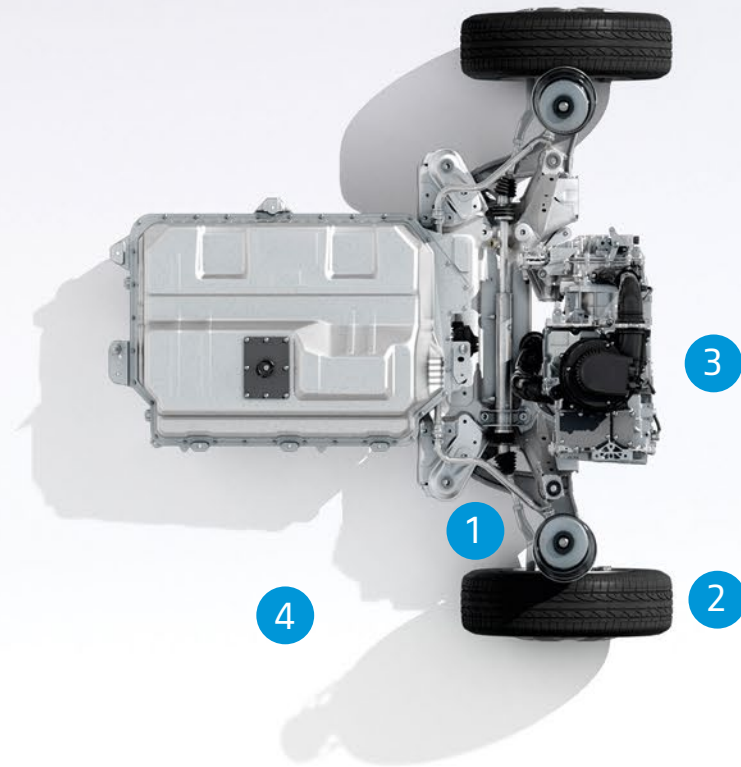

**3. Eco mode.** When you activate this, you reduce the power output of the vehicle so that you can travel further (less abrupt acceleration and maximum speed of 50 mph).

**4. 7 kW charger.** Recharge the battery in just 6 hours with a 32 A/7 kW Wallbox. The recharging flap located on the right-hand side of the cab, is easily accessible.

# Driving range

Master E-Tech electric is now available with the E-Tech electric battery giving a WLTP\* range of 95 (city cycle) miles on one charge, meaning range anxiety is a thing of the past. With real life estimates of 75 miles in summer and 50 miles in winter\*\*.

WLTP range* combined cycle (miles)	WLTP range* city cycle (miles)	Summer (+20°C)	Winter** (-5°C)	Cost in pence p/per mile†	Cost per full recharge†
75	95	75	50	Less than 7p	Less than £5

\*What is WLTP and why the real-life range is similar to it?

Worldwide Harmonized Light Vehicles Test Procedures (WLTP), this new homologation protocol gives fuel consumption and driving range results that are much closer to real life conditions figures than the NEDC protocol. While the old NEDC test determined test values based on a theoretical driving profile, the WLTP cycle was developed using real-driving data, gathered from around the world. WLTP therefore better represents everyday driving profiles.

\*\*Why is the range reduced in winter?

Like all batteries, those in E-Tech electric vehicles are less efficient in cold weather than at warmer ambient temperatures. This means that you can expect a reduction in the range of your Master E-Tech electric in the winter. Also, in winter you are more likely to use the heating, which means Master E-Tech electric consumes more energy.

## Charging solutions – options that suit your needs!

We offer you several charging solutions to make sure your vehicle is always ready to go!

Type of charger	Where to use it	Power required	Charging times (0-100%)	
Home (3-pin plug cable)*	Home / Office	2.3kW/10A	17 hours	Occasional slow charging. *Requires additional purchase of a EVSE cable.
	Home / Office	3.3kW/14A	12 hours	
Wallbox / Public charging point	Home / Office / On the go	3.7kW/14A	11 hours	Leaving the Master to charge overnight on a 3.7kW charger ensures that it will be ready for when you to begin your next day.
	Home / Office / On the go	7kW	6 hours	
Public charging point	On the go	22kW	6 hours	A standard charging time of 6 hours means your vehicle is ready to go when you are.
	On the go	43kW	6 hours	

†Less than £5 full recharge cost based on 6 hours of 14.4p per kWh (Source: UK Power) Full recharge of the 33 kWh battery.

(1) For illustration purposes only, may not reflect real-life journeys.

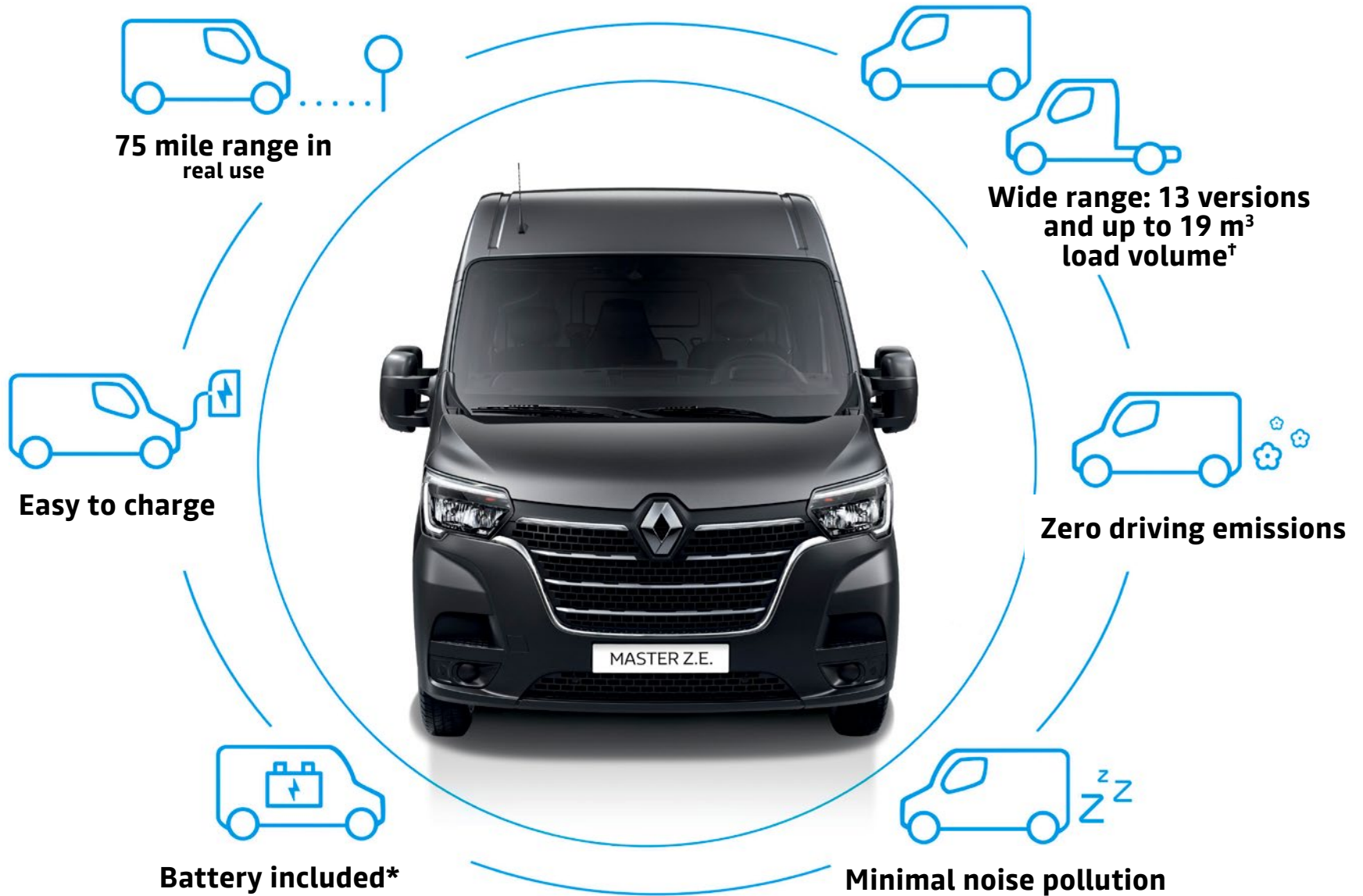

\*Battery guarantee of 5 years / 62,000 miles, whichever comes first, this includes the battery performance guarantee to at least 70% of its original capacity.  
†Requires conversion

# Colours

Mineral White (S)



Persian Blue (S)



Urban Grey (S)



Star Grey (M)



Tempest (M)



Pearl Black (M)



Carmen Red (S)



	Mineral White (QNG)	Urban Grey (KPW)	Carmen Red (719)	Persian Blue (RNQ)	Star Grey (KNH)	Tempest (J47)	Pearl Black (676)
Business	●	●	●	●	○	○	○
Business+	●	●	●	●	○	○	○

● = Standard (therefore no cost) ○ = Optional

(S) Solid paint (M) Metallic paint

Every effort has been made to ensure that the information, descriptions, and images were correct at the time of publication however images may not always reflect the exact version selected. It should be noted that limitations on screen do not permit the subtle paintwork shades on this page to be shown with absolute accuracy.



# Standard features



16" steel wheels



Kaleido



## BUSINESS

### Technology

- Radio with DAB, Bluetooth and USB
- 6-speed gearbox
- ESC (Electronic Stability Control) with Grip Xtend, Hill Start Assist and Trailer Swing Assist
- Trip computer - multi-functional

### Interior

- Closed glove box
- 2 cup holders on centre console
- Driver's seat - height adjustable and lumbar adjustment
- Steering wheel - height adjustment
- Electric front windows
- Passenger bench seat
- Overhead parcel shelf
- Kaleido - dark grey upholstery

### Exterior

- Left side loading door - unglazed
- 80-litre fuel tank
- 22-litre AdBlue tank
- C-Shaped DRL's (Daytime running lights)
- Door mirrors - electric adjustment, heated
- 16" steel wheels with small wheel stylers
- Rear doors - unglazed, 180°
- Spare wheel

### Safety and security

- Side wind assist
- Full-steel bulkhead
- ABS with EBD (Electronic Brake force Distribution)
- Alarm (Thatcham approved category 1, volumetric and perimeter) (excluding Master E-Tech electric)
- Electronic immobiliser
- Remote central locking (foldable 2 button key)
- Airbag - driver

- Seatbelts - 3 point height-adjustable seatbelts with pretensioners
- Seatbelt warning - driver and passenger
- 4 disc brakes
- Automatic headlights and wipers
- Deadlocking
- Rear running board and handles
- Anchorage points : L1 - 6, L2 - 8, L3 - 10, L4 - 12
- Weight allowed per anchorage point: approximately 500kg'

### Specific E-Tech electric Equipment

- E-Tech electric charging socket (right-hand side)
- E.V. Voice: emits a distinctive range of sounds signalling that the vehicle is moving
- Engine speed limiter 62 mph
- Standard charging cable 32A (IEC 62196 - Type 2 Mennekes) 6m
- Tyre repair kit (replaces spare wheel)

### Crew Van adds

- 2nd row of 4 passenger seats
- Battery interface
- Integrated storage nets and cup holders
- Single passenger seat (LWB versions)
- Left and right side loading doors - glazed
- Bulkhead - full-steel with glazing

### RWD additional equipment

- Rear step
- Side marker lights (LWB or MWB with extended overhang only)
- Lane departure warning system (4.5T versions only)
- Engine speed limiter 56mph (to meet legal requirement) - 4.5T version only
- Digital tachograph (4.5T version only) and CAN interface unit

# Standard features

---



16" steel with large wheel stylers



Kaleido



## **BUSINESS+** (in addition to Business)

### **Interior**

- Manual air conditioning and pollen filter
- Electric front windows - driver's side one touch descending
- Driver's seat - fully adjustable suspension type with armrest (panel vans only, not crew vans)
- Interior chrome trim
- Pivoting seatback table with dual split underseat storage compartment
- 12V power socket in load area

### **Exterior**

- 16" steel wheels with large wheel stylers
- Chrome trim on front grille

### **Safety and Security**

- Wide view mirror
- Key - 3 button key
- Rear parking sensors

# Standard features - Conversions

## BUSINESS



Platform cab



Chassis cab

## Chassis Cab and Platform Cab

### Technology

- Radio with DAB, Bluetooth\* and USB
- 6-speed gearbox
- ESC (Electronic Stability Control) with Grip Xtend, Hill Start Assist and Trailer Swing Assist
- Trip computer - multi-functional

### Interior

- Closed glove box
- 2 cup holders on central console
- Driver's seat - height adjustable with lumbar adjustment
- Steering wheel - height adjustment
- Electric front windows
- Passenger bench seat
- Overhead parcel shelf
- Kaleido - dark grey upholstery

### Exterior

- 80-litre fuel tank
- 22-litre AdBlue tank
- C-Shaped DRL's (Daytime running lights)
- Door mirrors - electric adjustment, heated
- 16" steel wheels with small wheel stylers
- Side marker lights wiring (on LL, MLL and LLL versions only)
- Spare wheel

### Safety and security

- Full-steel bulkhead
- ABS with EBD (Electronic Brake force Distribution)
- Automatic headlights and wipers
- Electronic immobiliser
- Alarm (Thatcham approved category 1, volumetric and perimeter) (excluding Master E-Tech electric)
- Remote central locking (foldable 2 button key)
- Airbag - driver
- Bulkhead - full-steel with glazing (full-steel bulkhead on Platform Cab and Luton Low Loader, unglazed)
- 4 disc brakes
- Deadlocking

### RWD adds

- Digital tachograph (4.5T versions only) and CAN interface unit
- Engine speed limiter 56mph (to meet legal requirement) (4.5T version only)

### Double cab adds

- Second row of 4 passenger seats
- Single passenger seat on all Factory Tippers and Twin Rear Wheel Dropsides only\*\*
- Left and right rear lateral doors - glazed

For more details about our range of Off-the-shelf and Tailor Made accredited conversions please see our separate Conversions Range brochure

\*For compatible devices, please refer to <https://renault-connect.renault.co.uk/phone-pairing>

\*\*Passenger bench not available

## CONVERTED PRODUCTS



Dropside



Tipper



Box Van



Luton Low Loader

### Chassis Cab and Platform Cab

#### Dropside adds

- Hot-galvanised steel front side panel and platform
- Anti-slip wooden floor
- Anchorage points in loading area (6 to 8 depending on version)  
Weight allowed per anchorage point: approximately 500kg
- Folding and removable aluminium side and rear panels (400mm high)
- Foldaway step on rear side panel
- Steel cab protecting grid with ladder/long object rack
- Rear corner pillars
- Version available with a tail lift as standard (Del 500kg mesh platform tail lift with 915mm platform and fixed leading edge)
- Additional options available on request via VFS

#### Tipper adds

- Rear tipping "Scattolini" body (45°)
- Hot-galvanised steel loading deck (2 mm thick)
- Aluminium side and rear panels (400 mm high)
- Aluminium cab protecting grid with ladder/long object rack

#### Luton Box Van adds

- 11 mm thick GRP side panels, with fibreglass roof skin on a 65 mm alloy frame
- 15 mm thick wisdeck birch floor
- Luton front providing over-the-cab storage fitted as standard
- Rear doors - roller shutter on alloy frame with rear columns designed to support column mounted tail lift
- Version available with a tail lift as standard (Del 500kg column tail lift with 815mm alloy platform and fixed leading edge one-two button external control)
- Additional options available on request via Truckcraft Bodies

#### Luton Low Loader adds

- 11 mm thick GRP side panels, with fibreglass roof skin on a 65 mm alloy frame
- 15 mm thick wisdeck birch floor
- Luton front providing over-the-cab storage fitted as standard
- Rear doors - 270° opening barn doors
- Additional options available on request via Truckcraft Bodies
- Tyre repair kit (replaces spare wheel)

#### Specific E-Tech Equipment

- E-Tech electric charging socket (right-hand side)
- E.V. Voice: emits a distinctive range of sounds signalling that the vehicle is moving
- Engine speed limiter 62 mph
- Standard charging cable 32A (IEC 62196 - Type 2 Mennekes) 6m
- Tyre repair kit (replaces spare wheel)

For more details about our range of Off-the-shelf and Tailor Made accredited conversions please see our separate Conversions Range brochure

\*For compatible devices, please refer to <https://renault-connect.renault.co.uk/phone-pairing>

\*\*Passenger bench not available



# Upholstery and wheel trims



**Kaleido black and grey fabric**  
Standard on Business and Business+

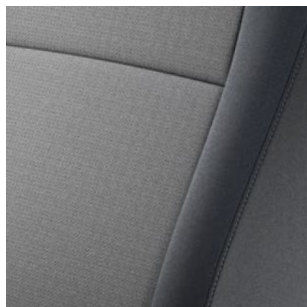

**Black and dark carbon Kompo fabric**  
Optional (Not available on Business+ and RWD)

## Wheels



**16" Steel wheels with small wheel stylers**  
Standard on Business



**16" Steel wheels with large wheel stylers**  
Standard on Business+



**16" Alloy wheels**  
Optional (FWD only)

## Tyres

TYPE OF TYRES	Euro 6d-Temp emissions standards			Euro 6VI emissions standards				E-Tech electric	
	SUMMER		ALL WEATHER	SUMMER		ALL WEATHER		SUMMER	
GVW/Transmission	2.8 t, 3.3 t and 3.5 t/Front-wheel drive		2.8 t, 3.3 t and 3.5 t/ Front-wheel drive	3.5 t/Front-wheel drive	3.5 t/Single wheel rear-wheel drive	3.5 t and 4.5 t/Twin wheel rear-wheel drive	2.8 t, 3.3 t and 3.5 t/ Front-wheel drive	3.5 t and 4.5 t/Twin wheel rear-wheel drive	3.1t/Front-wheel drive
Tyre/wheel size	225/65R16			225/65R16	235/65R16	195/75R16	225/65R16	195/75R16	215/65R16
Make	Bridgestone Duravis	Continental Vancontact	Continental Vancontact 4 Seasons	Continental Vancontact	Michelin Agilis	Continental Vancontact	Continental Vancontact 4 Seasons	Continental Vancontact 4 Seasons	Continental Vancontact
Fuel efficiency class	A	A	B	A	B	B	B	E	A
Wet grip class	A	A	A	A	A	A	A	C	A
Exterior noise (dB)	72	72	73	72	72	72	73	72	72

# The range

---

## Closed transport

You have a wide range of different needs, which can be met by the wide variety of interior fittings and length x height combinations of Renault Master, with a loading volume of between 8 and 20 m<sup>3</sup>.



FWD Panel van



Crew van



RWD Panel van



Box van



Luton Low Loader

## Conversions

Renault Master is available in a number of versions, including Tipper, Chassis cab or Platform cabs which are ideal for a number of different conversions.



Tipper



Dropside



Platform cab



Chassis cab

# Dimensions

## Front-wheel drive panel van

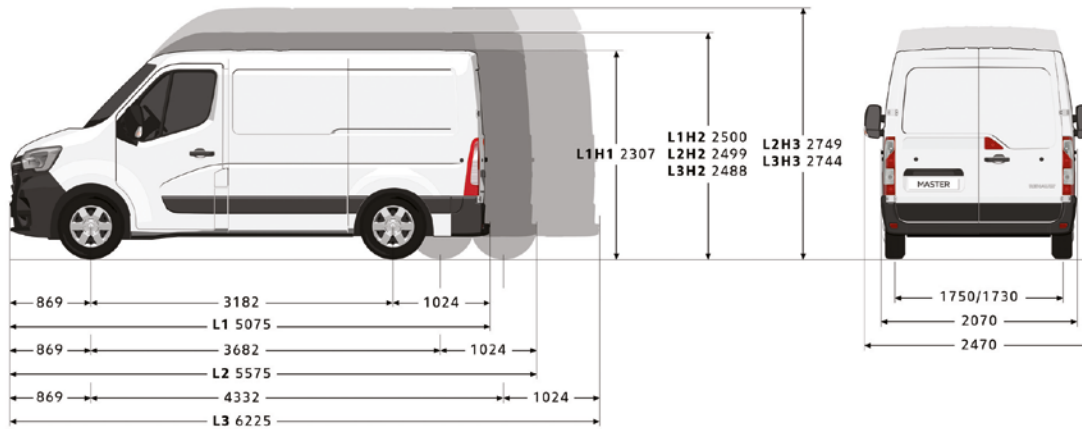

## WEIGHTS AND LOADS Front-wheel drive panel van (kg)

	Effective volume (m <sup>3</sup> )		GVW	
			3.1 T Master E-Tech electric	3.5 T Master E-Tech electric
L1H1	8	Min. kerb weight <sup>(1)</sup>	2,022	N/A
		Max. payload <sup>(2)</sup>	1,078	N/A
		Roof payload	150	
		Max. load on front axle	1,550	N/A
L1H2	9	Max. load on rear axle	1,650	N/A
		Min. kerb weight <sup>(1)</sup>	2,050	2,075
		Max. payload <sup>(2)</sup>	1,050	1,425
		Roof payload	150	
L2H2	10.8	Max. load on front axle	1,650	1,850
		Max. load on rear axle	1,900	2,100
		Min. kerb weight <sup>(1)</sup>	2,094	2,119
		Max. payload <sup>(2)</sup>	1,006	1,381
L3H2	13	Roof payload	200	
		Max. load on front axle	1,700	1,850
		Max. load on rear axle	1,900	2,100
		Min. kerb weight <sup>(1)</sup>	2,175	2,200
L3H3	14.8	Max. payload <sup>(2)</sup>	925	1,300
		Roof payload	200	
		Max. load on front axle	1,700	1,850
		Max. load on rear axle	1,900	2,100

## WEIGHTS AND LOADS Front-wheel drive panel van (kg)

	Effective volume (m <sup>3</sup> )		GVW						
			2.8 t Business	2.8 t Business+	3.3 t Business	3.3 t Business+	3.5 t Business	3.5 t Business+	
L1H1	8	Min. kerb weight <sup>(1)</sup>	1,927	1,952	-	-	-	-	
		Max. payload <sup>(2)</sup>	873	848	-	-	-	-	
		Roof payload	150						
L1H2	9	Min. kerb weight <sup>(1)</sup>	-	-	-	-	1,949	-	
		Max. payload <sup>(2)</sup>	-	-	-	-	1,551	-	
		Roof payload	-	-	-	-	150	-	
L1H1/L1H2		Max. load on front axle	1,550	1,550	-	-	1,850	-	
		Max. load on rear axle	1,650	1,650	-	-	2,100	-	
		Max. towing weight (braked/unbraked)	2,500/750				2,500/750		-
		Turning circle, kerb to kerb	12.0 m						12.0 m
L2H2	10.8	Turning circle, wall to wall	12.5 m						12.5 m
		Min. kerb weight <sup>(1)</sup>	-	-	2,021	2,046	2,021	2,046	
		Max. payload <sup>(2)</sup>	-	-	1,279	1,254	1,479	1,454	
		Roof payload	-	-	200				
L2H3	12.3	Min. kerb weight <sup>(1)</sup>	-	-	-	-	2,046	-	
		Max. payload <sup>(2)</sup>	-	-	-	-	1,454	-	
		Roof payload	-	-	-	-	200	-	
L2H2/L2H3		Max. load on front axle	-	-	1,850	1,850	1,850	1,850	
		Max. load on rear axle	-	-	2,100	2,100	2,100	2,100	
		Max. towing weight (braked/unbraked)	-	-	2,500/750				
		Turning circle, kerb to kerb	-	-	13.6 m				
L3H2	13	Turning circle, wall to wall	-	-	14.1 m				
		Min. kerb weight <sup>(1)</sup>	-	-	-	-	2,116	2,141	
		Max. payload <sup>(2)</sup>	-	-	-	-	1,384	1,359	
		Roof payload	-	-	-	-	200		
L3H3	14.8	Min. kerb weight <sup>(1)</sup>	-	-	-	-	2,123	-	
		Max. payload <sup>(2)</sup>	-	-	-	-	1,377	-	
		Roof payload	-	-	-	-	200	-	
L3H2/L3H3		Max. load on front axle	-	-	-	-	1,850	1,850	
		Max. load on rear axle	-	-	-	-	2,100	2,100	
		Max. towing weight (braked/unbraked)	-	-	-	-	2,500/750	2,500/750	
		Turning circle, kerb to kerb	-	-	-	-	15.7 m	13.6 m	
Turning circle, wall to wall	-	-	-	-	16.2 m	14.1 m			

(1) The kerb weight is the weight of the vehicle without the driver and with the fuel tank filled to 90%. This weight may vary according to the equipment and engine (by up to 330 kg). (2) The payload is calculated as the difference between the Gross Vehicle Weight (GVW) and the kerb weight.

## INTERIOR DIMENSIONS Front-wheel drive panel van (mm)

	L1H1	L1H2	L2H2	L2H3	L3H2	L3H3
<b>Loading area</b>						
Effective length	2,583		3,083		3,733	
Effective length at 1.1 m	2,530		3,030		3,680	
Effective width	1,765					
Width between wheel arches	1,380					
Effective height	1,700	1,894	2,144	1,894	2,144	
<b>Sliding side door(s)</b>						
Width of sliding side door(s)	1,050		1,270			
Height of sliding side door(s)	1,581	1,780				
<b>Rear door</b>						
Width (169 mm from floor)	1,580					
Entrance height	1,627	1,820				
Loading sill (min./max.)	546/564	544/563	545/562	543/560	543/557	542/555
Ground clearance (min)	182		174	173	172	169



## Rear-wheel drive panel van

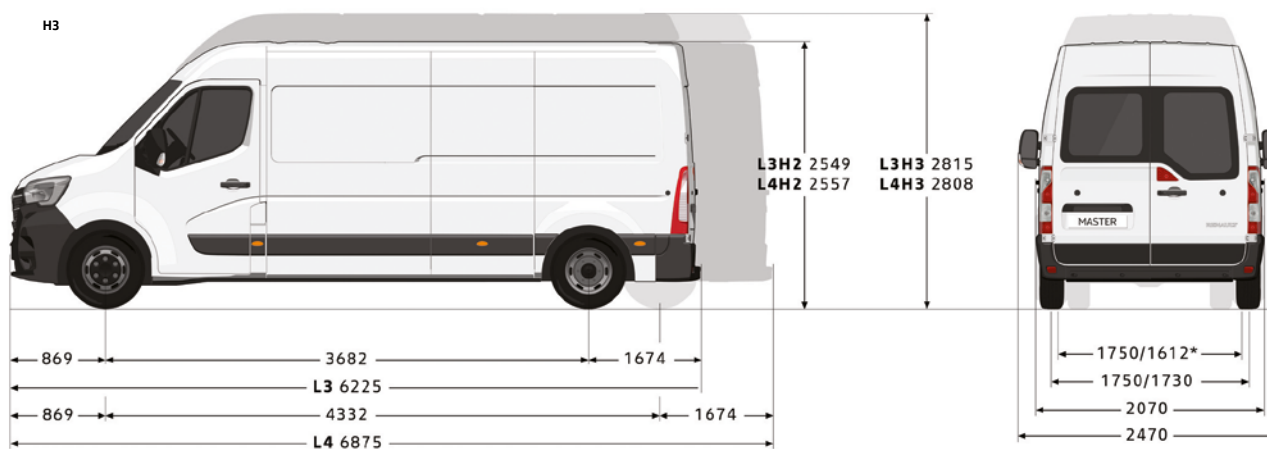

\* Twin wheels.

### WEIGHTS AND LOADS Rear-wheel drive panel van (kg)

	Effective volume (m <sup>3</sup> )		GVW		
			3.5 t SW	3.5 t TW	4.5 t TW
L3H2 Long Overhang	14.9	Min. kerb weight <sup>(1)</sup>	2,343	2,439	2,439
		Max. payload <sup>(2)</sup>	1,157	1,061	2,061
		Roof payload	200		
L3H3 Long Overhang	17	Min. kerb weight <sup>(1)</sup>	2,390	2,510	2,510
		Max. payload <sup>(2)</sup>	1,110	990	1,990
		Roof payload	200		
L3H2 Long Overhang SW/ L3H3 Long Overhang SW		Max. load on front axle	1,850		
		Max. load on rear axle	2,300	2,445	3,145
		Max. towing weight (braked/unbraked)	2,500/750		
		Turning circle, kerb to kerb 14.1 m	13.6-15.7		
		Turning circle, wall to wall 13.6 m	14.1-16.2		

(1) The kerb weight is the weight of the vehicle without the driver and with the fuel tank filled to 90%. This weight is given for the basic version and may vary according to the equipment and engine (by up to 330 kg). (2) The payload is calculated as the difference between the Gross Vehicle Weight (GVW) and the kerb weight.

### INTERIOR DIMENSIONS Rear-wheel drive panel van (mm)

	L3H2 Long overhang SW	L3H2 Long overhang TW	L3H2 Long overhang SW	L3H3 Long overhang TW
<b>Loading area</b>				
Effective length	4,383			
Effective length at 1.1 m	4,330			
Effective width	1,765			
Width between wheel arches	1,380	1,080	1,380	1,080
Effective height	1,798		2,048	
<b>Sliding side door(s)</b>				
Width of sliding side door(s)	1,270			
Height of sliding side door(s)	1,684			
<b>Rear door</b>				
Width (169 mm from floor)	1,580			
Entrance height	1,724			
Loading sill (min./max.)	682/704	701/717	680/702	700/715
Ground clearance (min)	167			

SW: single wheels. TW: twin wheels.

# Dimensions

## Crew van

### FRONT-WHEEL DRIVE

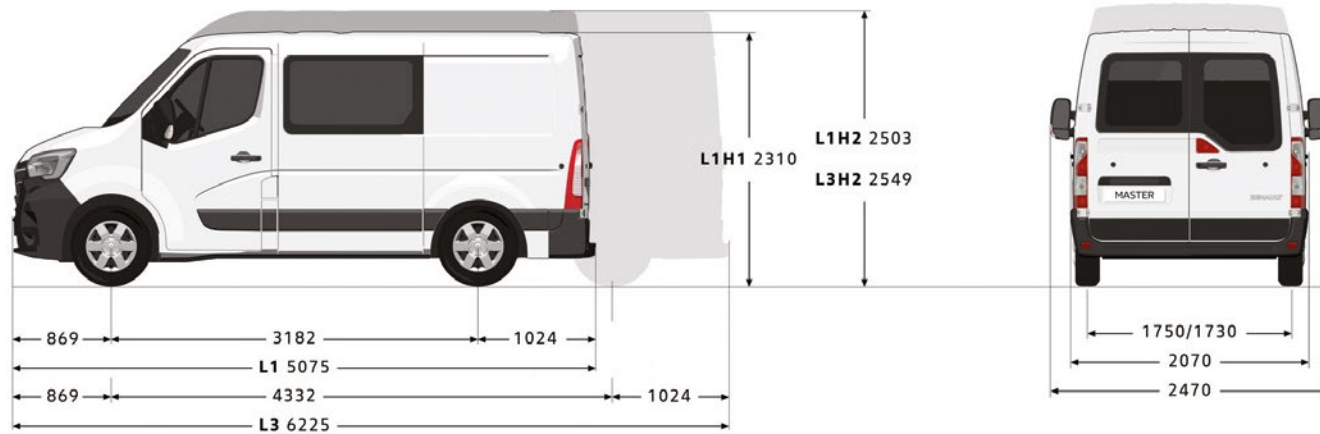

#### WEIGHTS AND LOADS Crew van (kg)

	Max. payload	Roof payload	Effective volume m <sup>3</sup>
<b>GVW</b>		3.5 t	
L3H2 FWD Business	1,180	200	9
L3H2 FWD Business+	1,155		9

SW: single wheels. TW: twin wheels.

#### INTERIOR DIMENSIONS Crew van (mm)

	Front-wheel drive
	L3H2
<b>Loading area</b>	
Effective length at 0.4 m	2,825
Effective length at 1 m	2,640
Effective width	1,765
Width between wheel arches	1,380
Effective height	1,798
<b>Sliding side door(s)</b>	
Width of sliding side door(s)	1,270

#### INTERIOR DIMENSIONS Crew van (mm) (continued)

	Front-wheel drive
	L3H2
Height of sliding side door(s)	1,684
<b>Rear door</b>	
Width at the lower part	1,580
Height	1,724
Loading sill (min./max.)	543/557
Ground clearance	172

SW: single wheels. TW: twin wheels.

## Luton Box Van

### FRONT-WHEEL DRIVE

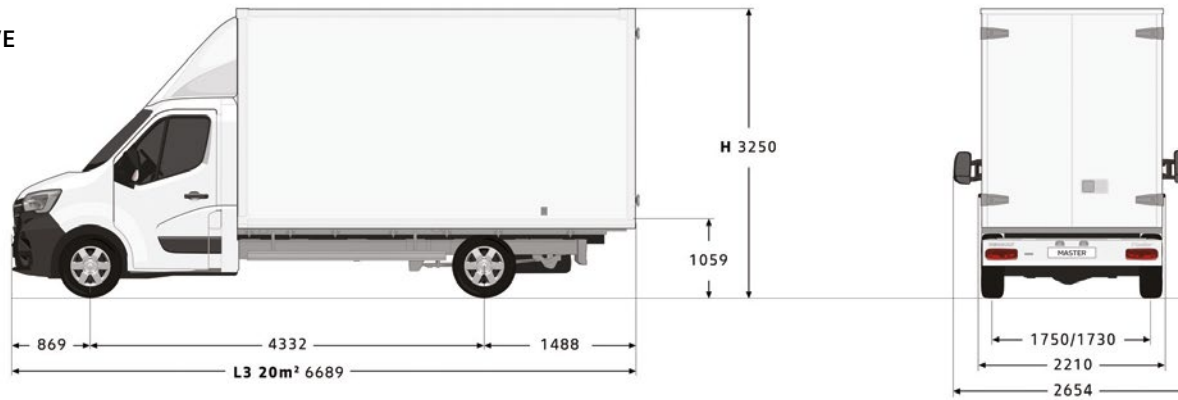

### REAR-WHEEL DRIVE

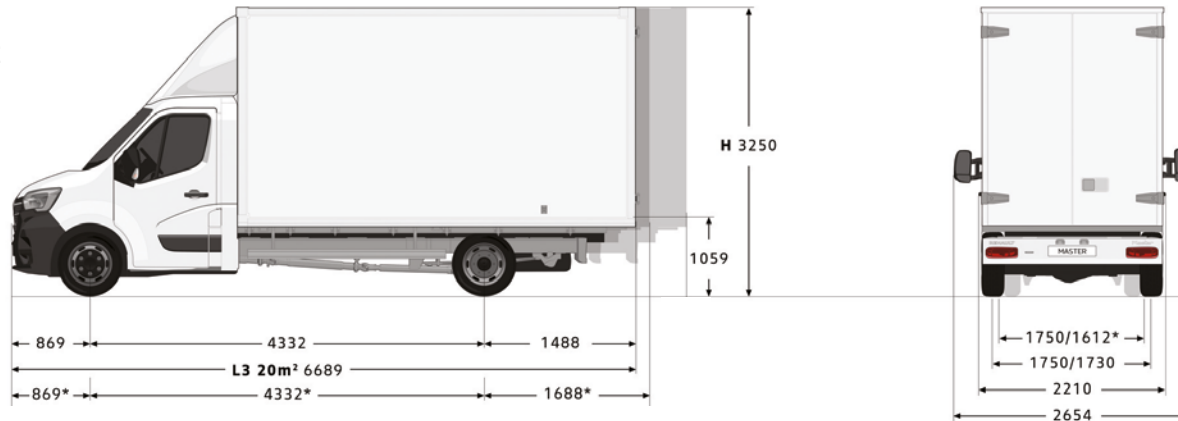

\* Twin wheels.

### WEIGHTS AND LOADS Box van (kg)

	Max. payload (kg)	Effective volume m <sup>3</sup>
<b>GVW</b>	<b>3.5 t</b>	
L3 Front-wheel drive 20 m <sup>3</sup>	1,204	20.1
L3 SW Rear-wheel drive 20 m <sup>3</sup>	1,061	20.1

SW: single wheels. TW: twin wheels.

### INTERIOR DIMENSIONS Box van (mm) (cont.)

	Front/Rear-wheel drive box van 20 m <sup>2</sup> on L3
<b>Box van module</b>	
Effective length	4,170
Effective width	2,220
Effective height	2,200

### INTERIOR DIMENSIONS Box van (mm)

	Front/Rear-wheel drive box van 20 m <sup>2</sup> on L3 (19.6 m <sup>3</sup> )
<b>Rear door</b>	
Width	2,105
Height	2,165

# Dimensions

## Tipper

### FRONT-WHEEL DRIVE

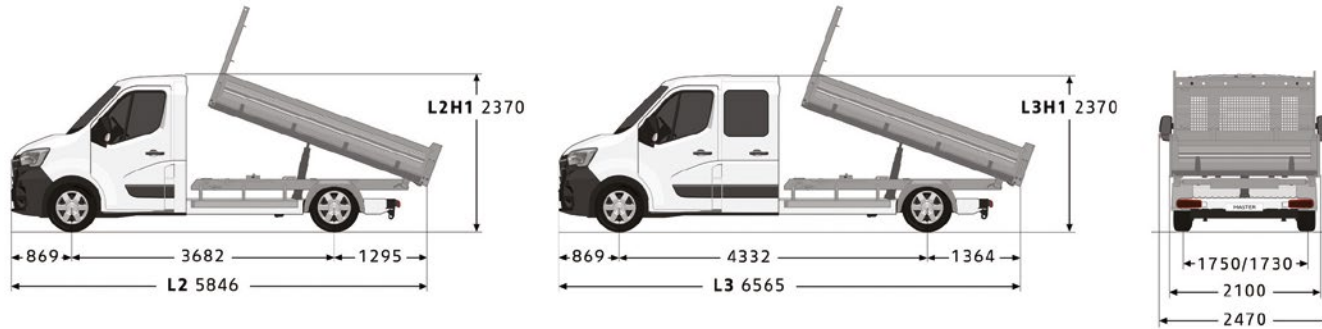

### REAR-WHEEL DRIVE

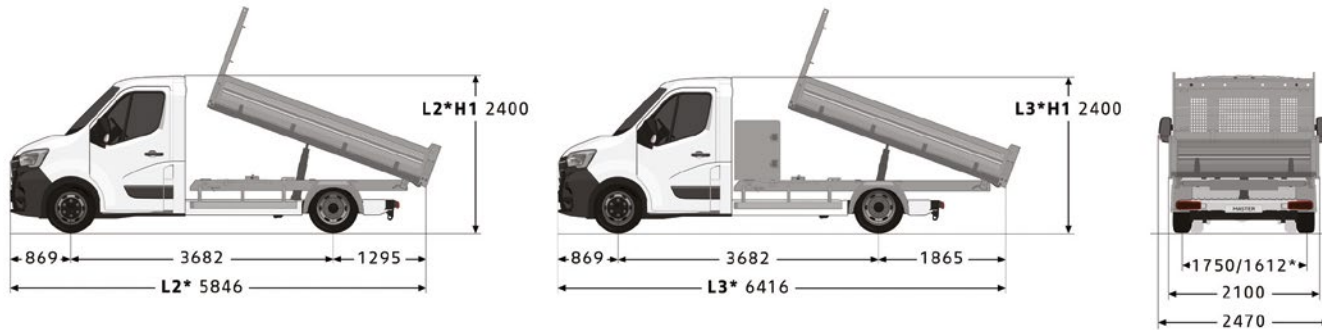

\* Twin wheels.

### WEIGHTS AND LOADS Tipper (kg)

	Single cab	Double cab
	Max. payload 3.5t	
GVW		
L2 Front-wheel drive with 3.3 m Tipper	1,217	-
L2 SW Rear-wheel drive with 3.3 m Tipper	1,104	-
L2 TW Rear-wheel drive with 3.3 m Tipper	934	-
L3 TW Rear-wheel drive with 3.2 m Tipper + boot	820	-
Double cab L3 SW Rear-wheel drive with 3.3 m Tipper	-	890
Double cab L2 Long Overhang TW Rear-wheel drive with 3.2 m Tipper	-	825*

### DIMENSIONS Tipper (mm)

	Single cab Tipper				Double cab Tipper	
	3.3 m		3.2 m + boot		3.3 m	
	L2		L3		L3	
	Front-wheel drive	Rear-wheel drive			Rear-wheel drive	
SW	SW	TW	TW	SW	TW	
Effective length	3,205		3,105		3,205	3,105
Effective width			2,040			
Side panel height			400			
Euro pallet capacity	6		5		6	5
Max. rear loading sill	1,020		1,080			1,080

Side panel thickness: 20 mm. Flatbed thickness: 2.5 mm. SW: single wheels. TW: twin wheels.

# Dropside

## FRONT-WHEEL DRIVE

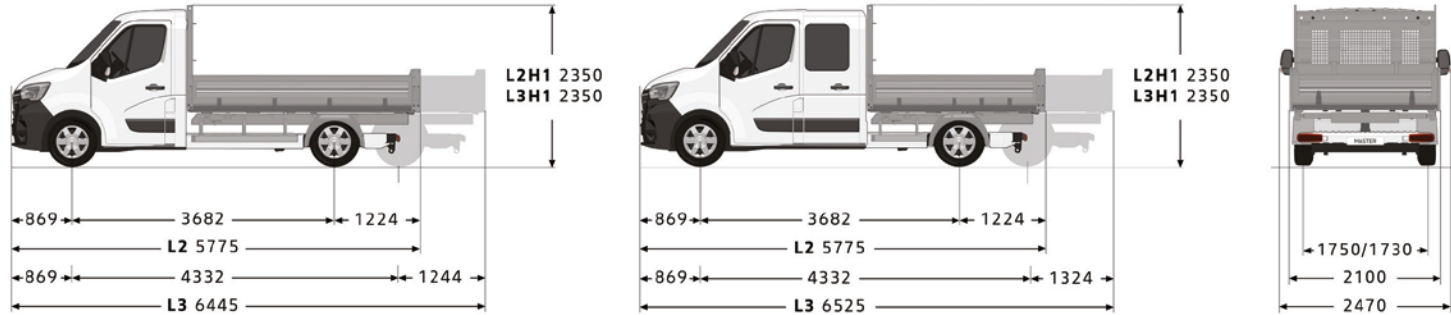

## REAR-WHEEL DRIVE

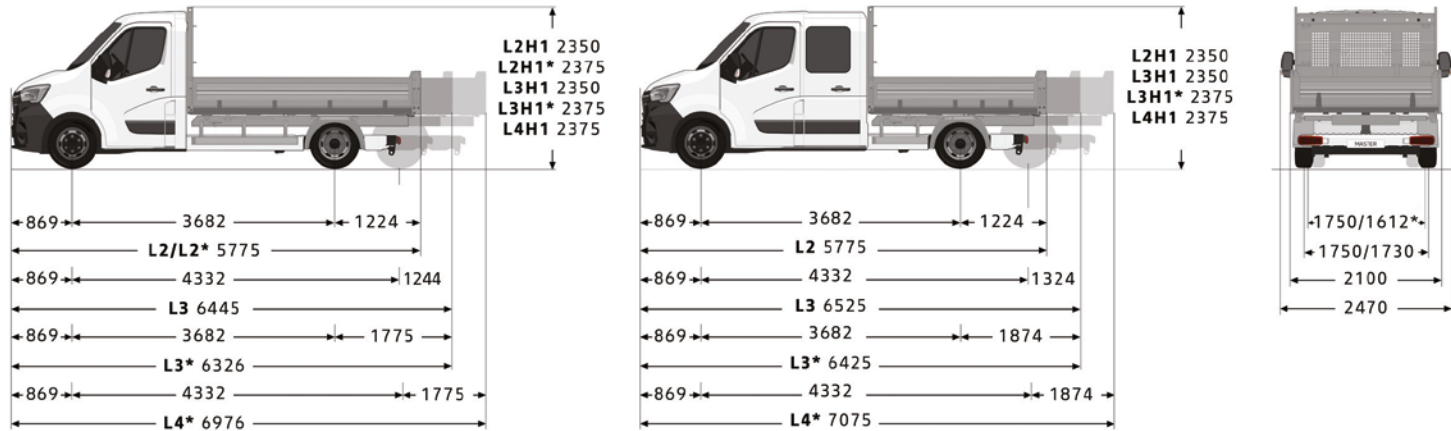

\* Twin wheels.

### WEIGHTS AND LOADS Dropside (kg)

	Single cab	Double cab
	Max. payload	
	3.5t	
L2 FWD	1,399	-
L3 FWD	1,333	1,206
L3 SW RWD	1,190	-
L3 Long Overhang TW RWD	945	-

SW: single wheels. TW: twin wheels.

### DIMENSIONS Dropside (mm)

	Single cab			Double cab
	L2	L3	L3 Long overhang	L3
	Front-wheel drive	Front-wheel drive	Rear-wheel drive	Front-wheel drive
Effective length	3,170	3,840	4,370	3,170
Effective width	2,040			
Side panel height	400			
Euro pallet capacity	5	7	8	5

Side panel thickness: 20 mm. Flatbed thickness: 3 mm. SW: singles wheels. TW: twin wheels.

# Dimensions

## Chassis single cab

### FRONT-WHEEL DRIVE

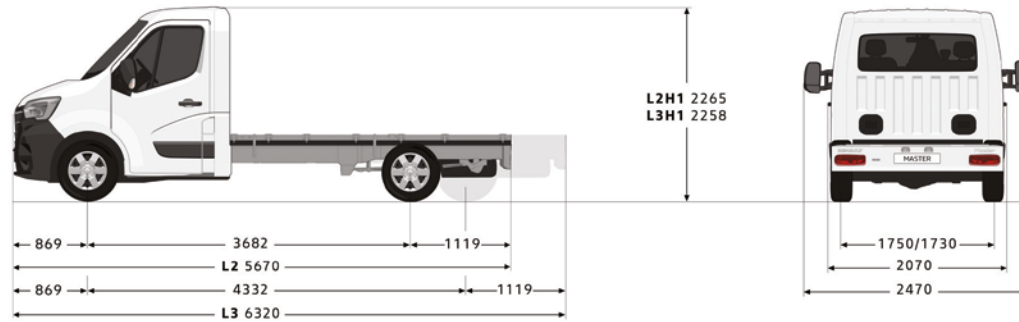

### REAR-WHEEL DRIVE

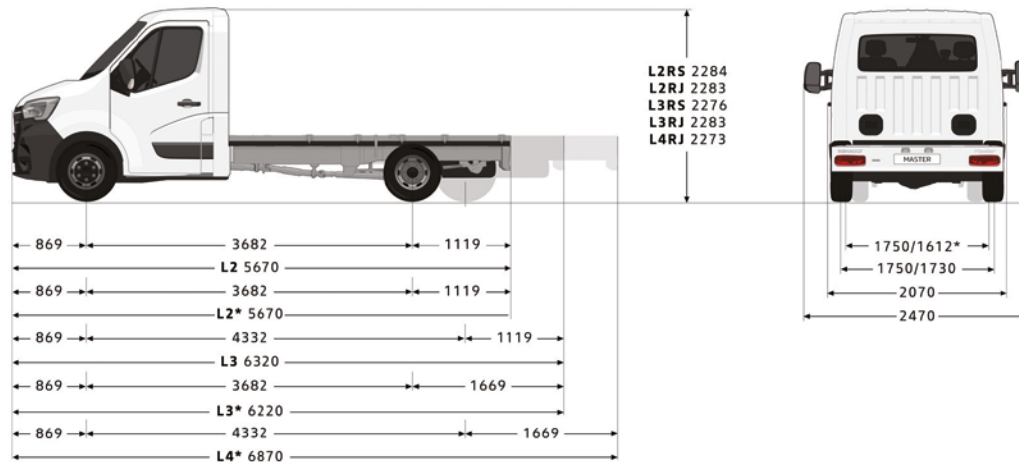

\* Twin wheels.

### WEIGHTS AND LOADS Chassis single cab (kg)

	Front-wheel drive			Rear-wheel drive							
	L2	L3	L2 SW	L2 TW	L3 SW	L2 Long overhang TW	L2 Long overhang TW	L3 Long overhang TW	L3 Long overhang TW		
<b>GVW</b>	<b>3.5t</b>								<b>4.5t</b>	<b>3.5t</b>	<b>4.5t</b>
Min. kerb weight diesel/electric	1,786/1,880	1,807/1,900	1,899	2,080	1,950	2,090	2,090	2,095	2,095		
Max. payload diesel/electric	1,714/1,620	1,693/1,600	1,601	1,420	1,550	1,410	2,410	1,405	2,405		
Max. load on front axle diesel/electric	1,850/TBC										
Max. load on rear axle diesel/electric	2,100/TBC		2,300	2,620	2,300	2,620	3,200	2,620	3,200		
Max. towing weight braked/unbraked/electric	2,500/750/0			3,000/750	2,500/750	3,000/750					
Turning circle, kerb to kerb	13.6m	15.7m	13.6m					15.7m			
Turning circle, wall to wall	14.1m	16.2m	14.1m					16.2m			

### DIMENSIONS Chassis single cab (mm)

	Front-wheel drive			Rear-wheel drive				
	L2	L3	L2 SW	L2 TW	L3 SW	L2 Long overhang TW	L3 Long overhang TW	
Maximum body length	5,670	6,320	5,670	5,670	6,320	6,220	6,870	
Effective body length (min./max.)	3,184/ 3,466	3,834/ 4,840	3,184/ 4,295	3,184/ 4,276	3,834/ 4,926	3,734/ 4,275	4,384/ 5,470	
Side member sill height	735/ 740	736/ 741	771/ 774	784/ 787	771/ 775	784/ 787	786/ 789	
Width with extended door mirrors	2,654							
Max. effective body width (standard/extended repeaters)	2,170/2,350							
Ground clearance (min)	166							

(1) The kerb weight is the weight of the vehicle without the driver and with the fuel tank filled to 90%. This weight is given for the basic version and may vary according to the equipment and engine (by up to 330 kg). (2) The payload is calculated as the difference between the Gross Vehicle Weight (GVW) and the kerb weight. SW: single wheels. TW: twin wheels.

## Chassis double cab

### FRONT-WHEEL DRIVE

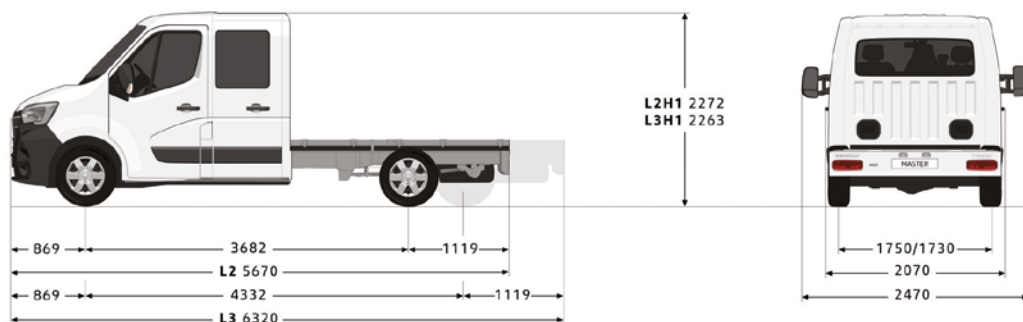

### REAR-WHEEL DRIVE

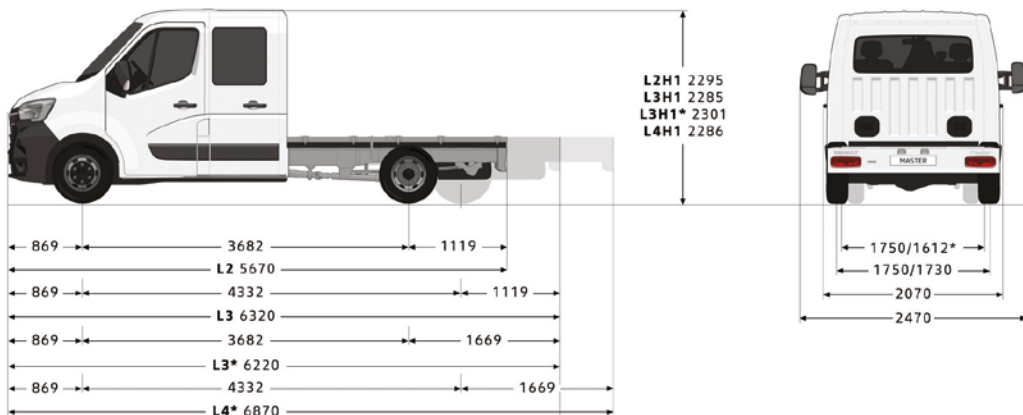

\* Twin wheels.

### WEIGHTS AND LOADS Chassis double cab (kg)

	Front-wheel drive		Rear-wheel drive	
	L2	L3	L3	L3 Long overhang
<b>GVW</b>	<b>3.5 t</b>			
Min. kerb weight <sup>(1)</sup>	1,971	1,979	2,245	2,294
Max. payload <sup>(2)</sup>	1,529	1,521	1,255	1,206
Max. load on front axle	1,850			
Max. load on rear axle	2,100		2,620	2,620
Max. towing weight braked/unbraked	2,500/750		3,000/750	
Turning circle, kerb to kerb	13.6 m	15.7 m	13.6 m	15.7 m
Turning circle, wall to wall	14.1 m	16.2 m	14.1 m	16.2 m

### DIMENSIONS Chassis double cab (mm)

	Front-wheel drive			
	L2	L3	L3 TW	L3 Long overhang TW
Maximum body length	5,670	6,320	6,220	6,870
Effective body length (min./max.)	2,434/ 2,516	3,084/ 4,044	2,985/ 3,416	3,635/ 4,436
Side member sill height (min./max.)	727/732	731/736	775/780	778/781
Width with extended door mirrors	2,654			
Maximum effective body width (with standard/extended repeater)	2,170/2,350			
Ground clearance (min)	169		167	

(1) The kerb weight is the weight of the vehicle without the driver and with the fuel tank filled to 90%. This weight is given for the basic version and may vary according to the equipment and engine (by up to 330 kg). (2) The payload is calculated as the difference between the Gross Vehicle Weight (GVW) and the kerb weight. SW: single wheels, TW: twin wheels.

# Dimensions

## Platform cab

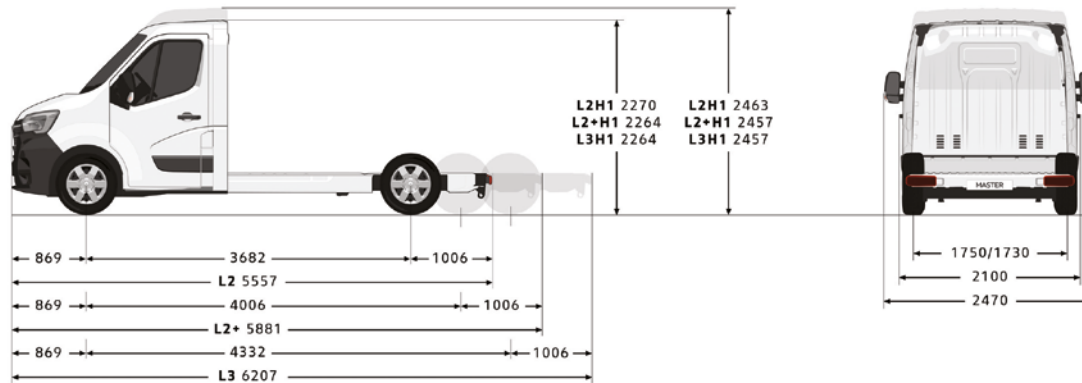

### WEIGHTS AND LOADS Platform cab (kg)

	E-Tech electric L2H1 Front-wheel drive	L2H1 Front-wheel drive	E-Tech electric L3H1 Front-wheel drive	L3H1 Front-wheel drive
<b>GVW</b>	3.1t	3.5t	3.1t/3.5t	3.5t
Min. kerb weight <sup>(1)</sup>	1,773	1,717	1795 / 1780	1,725
Max. payload <sup>(2)</sup>	1,327	1,783	1305 / 1720	1,775
Max. load on front axle	1,700	1,850	1700 / TBC	1,850
Max. load on rear axle	1,900	2,100	1900 / TBC	2,100
Max. towing weight braked/unbraked	0/0	2,500/750	0/0	2,500/750
Turning circle, kerb to kerb	13.6m	13.6m	15.7m	15.7m
Turning circle, wall to wall	16.2m	14.1m	16.2m	16.2m

### DIMENSIONS Platform cab (mm)

	L2H1	L3H1
Maximum body length	5,557	6,207
Effective body length (min./max.)	3,091/3,313	3,741/4,583
Maximum effective body width (with standard/extended repeater)	2,170/2,350	
Width with extended door mirrors	2,654	
Floor sill height (min./max.)	581/585	579/583
Ground clearance (min)	166	

(1) The kerb weight is the weight of the vehicle without the driver and with the fuel tank filled to 90%. This weight is given for the basic version and may vary according to the equipment and engine (by up to 330 kg). (2) The payload is calculated as the difference between the Gross Vehicle Weight (GVW) and the kerb weight.

## Luton Low Loader

### WEIGHTS AND LOADS Luton Low Loader (kg)

	L3H1 Front-wheel drive
<b>GVW</b>	3.5t
Min. kerb weight <sup>(1)</sup>	2,262
Max. payload <sup>(2)</sup>	1,238
Max. load on front axle	1,850
Max. load on rear axle	2,100
Max. towing weight braked/unbraked	2,500/750

### DIMENSIONS Luton Low Loader (mm)

	L3H1
Maximum body length	6,700
Maximum effective body width (without door mirrors)	2,070
Width with door mirrors	2,470
Interior height	2,200
Overall height (unladen)	2,840
Cargo area length	4,150
Maximum loading area width	2,036

(1) The kerb weight is the weight of the vehicle without the driver and with the fuel tank filled to 90%. This weight is given for the basic version and may vary according to the equipment and engine (by up to 330 kg). (2) The payload is calculated as the difference between the Gross Vehicle Weight (GVW) and the kerb weight.





MASTER

# Engines



## High-performance and more efficient engines

As part of the application of the Euro 6D-Full emission standard, Master has modernised its range of engines. Benefits: a 100% Twin Turbo range, more power (up to +10 hp), more torque (up to +40 Nm) for new driving pleasure and better acceleration. All of this significantly reduces fuel consumption and CO<sub>2</sub> emissions. Example: the dCi 135 hp Twin Turbo gains 5 hp, +40 Nm whilst reducing its consumption by up to 15% in combined cycle (NEDC-BT)<sup>(1)</sup> enabling a net improvement in the total cost of ownership.

### How do I choose?

- On rear-wheel drive models the Euro VI Emission standard engine range meets your expectations with the Blue dCi 145.
- On Front Wheel Drive models (non converted versions), the Blue dCi 150 and 180 versions can be combined with a 6-speed automatic gearbox.
- Let's also remind you of the electric engine of Master E-Tech electric, ideal for urban last mile delivery the last mile.

### "Twin Turbo" technology

It enables a diesel engine to combine torque at low speeds and high power with immediate benefit to driving pleasure. It incorporates two standard-mounted turbochargers:

- the first turbo provides high torque from low speeds to give you greater responsiveness when pulling away and restarting;
- the second turbo takes over at higher speeds, letting you use more power without running out of steam for smooth, steady, linear acceleration.

### Euro 6/VI and AdBlue®

The new range has the SCR (catalytic reduction system) enabling all of our engines to significantly reduce NO<sub>x</sub> emissions by injecting a liquid called AdBlue®. AdBlue® is a liquid, non-toxic, non-flammable and water-based solution, which is injected at the start of the exhaust system not line. This significantly reduces pollutant emissions while preserving the performance of our engines. The AdBlue® tank is located under the body at the front and is filled via a flap which is located on the right side of the vehicle (can be filled from a bottle, or HGV AdBlue® pump in service stations).

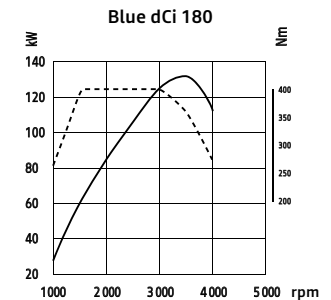
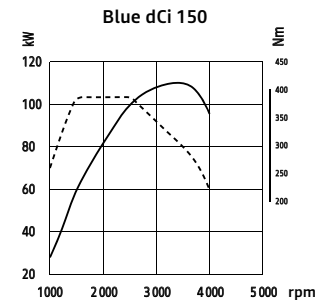
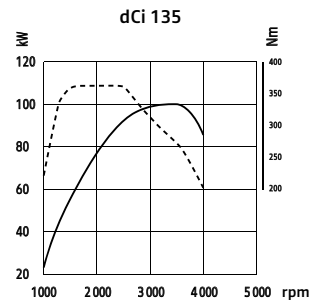

--- Torque (Nm)    — Power (hp)

# Technical specification

	dCi 110 BVM6 N1	dCi 135 BVM6 N1	BLUE dCi 150 BVM6/BVR6* N1		BLUE dCi 180 BVM6/BVR6* N1		E-Tech electric
Power (hp/kW)	110/81	135/100	150/110		180/132		76/57
Engine capacity (cc)	2298	2298	2298		2298		N/A
Stop & Start	No	No	Yes		No		No
Engine speed at max. power (rpm)	3,500	3,500	3,500		3,500		N/A
Torque (N.m)	330	360	385		400		225
Engine speed at max. torque (rpm)	1,500	1,500	1,500		1,500		N/A
Top speed (mph)	TBC	94	97		103		62
0-62 mph (s)	TBC	13.5	12.1		11.3		TBC
Fuel Tank Capacity - Gallons (l)			21.1 (80)				-
Battery Capacity (kWh)		-	-		-		33
AdBlue® Tank Capacity (l) <sup>(1)</sup>			22				-
BIO-fuel type			B7, B10, XTL				-
HVO type			HVO100 compliant				-
Type of bodywork	FWD vans, non-converted	FWD vans and crew vans, non-converted	Converted chassis cabs, tippers, dropside, platform cabs and FWD panel vans	FWD vans, non-converted	Converted chassis cabs, tippers, dropside, platform cabs and FWD panel vans	FWD vans, non-converted	FWD vans, non-converted
				BVM6 BVR6*		BVM6 BVR6*	
				WLTP <sup>(2)</sup>			
Combined fuel consumption (mpg)		TBC	TBC	TBC	TBC	TBC	245 kwh/mi
CO <sub>2</sub> emissions (g/km) (combined cycle)		TBC	TBC	TBC	TBC	TBC	0

(1) Actual fuel and AdBlue® consumption depends on vehicle use, equipment, the user's driving style and loading. (2) WLTP figures shown are for comparability purposes; only compare figures with vehicles tested to the same technical procedures. Actual real world driving results may vary depending on factors such as weather conditions, driving styles, vehicle load or any accessories fitted after registration. WLTP is a new test used for fuel consumption and CO<sub>2</sub> figures. Please visit [renault.co.uk/configure](http://renault.co.uk/configure) for WLTP figures for any selected options.

\*BVR6 automatic gearbox engine data.

	BLUE dCi 145	dCi 130	BLUE dCi 145	E-Tech electric
Type of bodywork	All FWD Vans and Conversions	RWD Conversions	All RWD Vans and Conversions	All FWD Vans and Conversions
Certification category	N1	N1	N1	N1
Wheels	SW	SW/TW	SW/TW	SW
Power (hp/kW)	145/107	130/96	145/107	76/57
Engine capacity (cc)	2298	2298	2298	N/A
Stop & Start	Yes	No	Yes	No
Engine speed at max. power (rpm)	3,500	3,500	3,500	N/A
Torque (N.m)	360	330	360	225
Engine speed at max. torque (rpm)	1,500	1,500	1,500	N/A
Top speed (mph)	95	92	93	62
Fuel Tank Capacity - Gallons (l)		21.1 (80)		-
Battery Capacity (kWh)	-	-	-	33
AdBlue® Tank Capacity (l) <sup>(1)</sup>		22		-
BIO-fuel type		B7, B10, XTL		
HVO type		HVO100 compliant		
			WLTP <sup>(2)</sup>	
Combined cycle consumption (mpg)	TBC	TBC	TBC	245 kwh/mi
CO <sub>2</sub> emissions (g/km) (combined cycle)	TBC	TBC	TBC	0

(1) Actual fuel and AdBlue® consumption depends on vehicle use, equipment, the user's driving style and loading. (2) WLTP figures shown are for comparability purposes; only compare figures with vehicles tested to the same technical procedures. Actual real world driving results may vary depending on factors such as weather conditions, driving styles, vehicle load or any accessories fitted after registration. WLTP is a new test used for fuel consumption and CO<sub>2</sub> figures. Please visit [renault.co.uk/configure](http://renault.co.uk/configure) for WLTP figures for any selected options.

^ All chassis comes with Rustproofing underneath the chassis - Cataphoresis (zinc phosphating paint bath), Mastic sealant & anti-gravel packing, Painting = primer + several layer painting.

# Master van pricing

## MASTER VAN - PANEL VAN

VERSIONS	WLTP CO <sub>2</sub> (g/km)*	Fuel Type	Combined fuel consumption (mpg)*	Load volume (m <sup>3</sup> )	Max. payload (kg)	VED 2021/22	Basic price (£)	VAT 20% (£)	Total retail price (£)*	On the road price*
<b>BUSINESS</b>										
<b>L1H1</b>										
FWD SL28 dCi 110 Business MY22	221	Diesel	33.6	8.0	873	£275	30,200	6,040	36,240	£37,270
FWD SL28 dCi 135 Business MY22	223	Diesel	33.2	8.0	873	£275	30,950	6,190	37,140	£38,170
FWD SL28 ENERGY dCi 150 Quickshift6 Business MY22	231	Diesel	32.1	8.0	873	£275	32,750	6,550	39,300	£40,330
<b>L1H2</b>										
FWD SM35 dCi 135 Business MY22	239	Diesel	31.0	9.0	1551	£275	33,450	6,690	40,140	£41,170
FWD SM35 ENERGY dCi 150 Quickshift6 Business MY22	248	Diesel	30.1	9.0	1551	£275	35,250	7,050	42,300	£43,330
<b>L2H2</b>										
FWD MM33 dCi 135 Business MY22	237	Diesel	31.4	10.8	1279	£275	33,550	6,710	40,260	£41,290
FWD MM35 dCi 110 Business MY22	233	Diesel	31.7	10.8	1479	£275	33,500	6,700	40,200	£41,230
FWD MM35 dCi 135 Business MY22	239	Diesel	31.0	10.8	1479	£275	34,250	6,850	41,100	£42,130
FWD MM35 ENERGY dCi 150 Business MY22	235	Diesel	31.7	10.8	1479	£275	35,300	7,060	42,360	£43,390
FWD MM35 ENERGY dCi 150 Quickshift6 Business MY22	249	Diesel	29.7	10.8	1479	£275	36,050	7,210	43,260	£44,290
<b>L2H3</b>										
FWD MH35 dCi 135 Business MY22	249	Diesel	29.7	12.3	1454	£275	35,450	7,090	42,540	£43,570
FWD MH35 ENERGY dCi 150 Business MY22	243	Diesel	30.4	12.3	1454	£275	36,500	7,300	43,800	£44,830
<b>L3H2</b>										
FWD LM35 dCi 110 Business MY22	235	Diesel	31.4	13.0	1384	£275	34,300	6,860	41,160	£42,190
FWD LM35 dCi 135 Business MY22	242	Diesel	30.7	13.0	1384	£275	35,050	7,010	42,060	£43,090
FWD LM35 ENERGY dCi 150 Business MY22	237	Diesel	31.4	13.0	1384	£275	36,100	7,220	43,320	£44,350
FWD LM35 ENERGY dCi 150 Quickshift6 Business MY22	252	Diesel	29.4	13.0	1384	£275	36,850	7,370	44,220	£45,250
FWD LM35 dCi 180 Business MY22	244	Diesel	30.4	13.0	1384	£275	36,900	7,380	44,280	£45,310
FWD LM35 dCi 180 Quickshift6 Business MY22	257	Diesel	28.8	13.0	1384	£275	37,650	7,530	45,180	£46,210
<b>L3H3</b>										
FWD LH35 dCi 135 Business MY22	251	Diesel	29.7	14.8	1377	£275	36,250	7,250	43,500	£44,530
FWD LH35 ENERGY dCi 150 Business MY22	245	Diesel	30.4	14.8	1377	£275	37,300	7,460	44,760	£45,790
FWD LH35 ENERGY dCi 150 Quickshift6 Business MY22	261	Diesel	28.5	14.8	1377	£275	38,050	7,610	45,660	£46,690
<b>L3H2 LONG OVERHANG</b>										
RWD LML35 ENERGY dCi 145 Business MY22	351	Diesel	21.1	14.9	1157	£275	38,070	7,614	45,684	£46,714
RWD LML35TW ENERGY dCi 145 Business MY22	359	Diesel	20.6	14.9	1061	£275	39,070	7,814	46,884	£47,914
RWD LML45TW ENERGY dCi 145 Business MY22	359	Diesel	20.6	14.9	1061	£165	40,820	8,164	48,984	£49,904
<b>L3H3 LONG OVERHANG</b>										
RWD LHL35 ENERGY dCi 145 Business MY22	351	Diesel	21.1	17.00	1110	£275	39,270	7,954	47,124	£48,154
RWD LHL35TW ENERGY dCi 145 Business MY22	359	Diesel	20.6	17.00	990	£275	40,270	8,054	48,324	£49,354
RWD LHL45TW ENERGY dCi 145 Business MY22	359	Diesel	20.6	17.00	1990	£165	42,020	8,404	50,424	£51,344
<b>BUSINESS+</b>										
<b>L1H1</b>										
FWD SL28 dCi 135 Business+ MY22	224	Diesel	33.2	8.00	848	£275	32,250	6,450	38,700	£39,730
<b>L2H2</b>										
FWD MM33 dCi 135 Business+ MY22	239	Diesel	31.0	10.8	1254	£275	35,050	7,010	42,060	£43,090
FWD MM35 dCi 135 Business+ MY22	241	Diesel	30.7	10.8	1454	£275	35,750	7,150	42,900	£43,930
FWD MM35 ENERGY dCi 150 Business+ MY22	236	Diesel	31.4	10.8	1454	£275	36,800	7,360	44,160	£45,190
FWD MM35 ENERGY dCi 150 Quickshift6 Business+ MY22	251	Diesel	29.7	10.8	1454	£275	37,550	7,510	45,060	£46,090
<b>L3H2</b>										
FWD LM35 dCi 135 Business+ MY22	244	Diesel	30.4	13.00	1359	£275	36,550	7,310	43,860	£44,890
FWD LM35 ENERGY dCi 150 Business+ MY22	239	Diesel	31.0	13.00	1359	£275	37,600	7,520	45,120	£46,150
FWD LM35 ENERGY dCi 150 Quickshift6 Business+ MY22	254	Diesel	29.1	13.00	1359	£275	38,350	7,670	46,020	£47,050

## MASTER CREW VAN - 6 SEATS

VERSIONS	WLTP CO <sub>2</sub> (g/km)*	Fuel Type	Combined fuel consumption (mpg)*	Load volume (m <sup>3</sup> )	Max. payload (kg)	VED 2021/22	Basic price (£)	VAT 20% (£)	Total retail price (£)*	On the road price*
<b>BUSINESS</b>										
<b>L3H2</b>										
FWD LM35 dCi 135 Business Crew Van MY22	248	Diesel	30.1	9.00	1180	£275	£37,430	£7,486	£44,916	£45,946
<b>BUSINESS+</b>										
<b>L3H2</b>										
FWD LM35 dCi 135 Business+ Crew Van MY22	249	Diesel	29.7	9.00	1155	£275	£38,930	£7,786	£46,716	£47,746

## MASTER E-TECH ELECTRIC PANEL VAN - BUSINESS - BATTERY FULL PURCHASE

VERSIONS	WLTP CO <sub>2</sub> (g/km) <sup>†</sup>	Power unit output kW (bhp)	Load volume (m <sup>3</sup> )	Max. payload (kg)	Basic price (£)	VAT 20% (£)	Total retail (£)*	Government grant (£)	Basic price after PiVG** exc VAT	Total retail price after PiVG***	On the road price after PiVG****
<b>L1H1</b>											
FWD SL31 E-Tech electric Business MY21	0	57 (76)	8.0	1078	tbc	tbc	tbc	tbc	tbc	tbc	tbc
<b>L1H2</b>											
FWD SM31 E-Tech electric Business MY21	0	57 (76)	9.0	1050	tbc	tbc	tbc	tbc	tbc	tbc	tbc
FWD SM35 E-Tech electric Business MY21	0	57 (76)	9.0	1425	tbc	tbc	tbc	tbc	tbc	tbc	tbc
<b>L2H2</b>											
FWD MM31 E-Tech electric Business MY21	0	57 (76)	10.8	1006	tbc	tbc	tbc	tbc	tbc	tbc	tbc
FWD MM35 E-Tech electric Business MY21	0	57 (76)	10.8	1381	tbc	tbc	tbc	tbc	tbc	tbc	tbc
<b>L3H2</b>											
FWD LM31 E-Tech electric Business MY21	0	57 (76)	13.0	925	tbc	tbc	tbc	tbc	tbc	tbc	tbc
FWD LM35 E-Tech electric Business MY21	0	57 (76)	13.0	1300	tbc	tbc	tbc	tbc	tbc	tbc	tbc

\*All prices shown are the manufacturer's recommended retail prices. The "On The Road" Price includes delivery to the dealer premises, number plates and a four-litre starter pack of AdBlue including funnel, 12 months government road fund licence at £275 (or £165 for vans with a GVW of more than 3.5 tonnes) and the First Registration Fee of £55. Other goods or services supplied by agreement between the customer and the dealer are not included. <sup>†</sup>Payload equals the Maximum Operating Mass (Gross Vehicle Mass or GVW) less the Kerb Mass. Kerb Mass is the weight of the complete vehicle including coolant, oil, a 90% full fuel tank, a 100% full AdBlue tank, spare wheel and jack, but excluding driver and crew. All Kerb Masses, and therefore Payloads quoted are subject to a 5% manufacturing tolerance and are based on the base level model. Any additional equipment added (options or accessories), or the selection of a higher trim level, could result in a higher Kerb Mass and a reduced Payload, and may increase CO<sub>2</sub> and decrease MPG figures. <sup>†</sup> WLTP figures shown are for comparability purposes; only compare figures with vehicles tested to the same technical procedures. Actual real world driving results may vary depending on factors such as weather conditions, driving styles, vehicle load or any accessories fitted after registration. WLTP is a new test used for fuel consumption and CO<sub>2</sub> figures. Please visit [renault.co.uk/configure](http://renault.co.uk/configure) for WLTP figures for any selected options. \*\* PiVG - Plug-in Van Grant. \*\*\* All prices shown are the manufacturer's recommended retail prices. i - Indicates with full battery purchase. \*\*\*\* For full terms and conditions visit [www.renault.co.uk/warranty](http://www.renault.co.uk/warranty). The "On The Road" price includes delivery to the dealer premises, 35% PiVG (up to a maximum of £5,000 for large vans weighting between 2.5-3.5 tonnes), number plates, 12 months government road £0 for Master E-Tech electric and First Registration Fee at £55. Other goods or services supplied by agreement between the customer and the Dealer are not included.

### LCV SERVICE PLAN

5 Years / 66,000 miles

**MRRP (inc VAT)**

£700

[5 Years / 66,000 miles - Master E-Tech electric](#)

£750

### LCV EXTENDED WARRANTY

5 Years / 100,000 miles

**MRRP (inc VAT)**

£785

[5 Years / 96,000 miles - Master E-Tech electric](#)

£630

**Service Plan Terms & Conditions** The Service Plan offer is available on all LCV's. Valid at participating Renault dealers only and may be purchased up to 12 months after registration or before the first service (whichever is sooner). Vehicles must be ordered between 01 December 2021 and 31 March 2022 and registered by 30 June 2022.

The Renault Service plan covers the manufacturer's minimum maintenance programme requirements for the term of the Service Plan purchased (refer to the Warranty and Service sheet in the Handover Document wallet for details). The plan ends when you reach the age or mileage limit (whichever comes first). Services must be carried out in line with the manufacturer's minimum maintenance programme requirements and servicing intervals within +/- 1 month or 1,000 miles of the service interval and can only be carried out at a Renault Approved outlet. Service plans do not cover wear and tear items such as (but not limited to) tyres, wiper blades or brakes. For Service plan full Terms & Conditions visit [www.renault.co.uk/owners](http://www.renault.co.uk/owners). Cannot be part exchanged, refunded or transferred. All prices quoted are MRRP.

**Extended Warranty Terms & Conditions** The Extended Warranties are available on all LCV's (excluding ZOE Van). Valid at participating Renault dealers only and are available to purchase from first date of registration and may be purchased up to 12 months after registration. For full Extended Warranty Terms and Conditions visit [www.renault.co.uk/extensions-of-warranties](http://www.renault.co.uk/extensions-of-warranties)

# Master options pricing

	Panel Diesel	Business Panel E-Tech electric	FWD Crew	Business+ Panel	Crew	RWD Business Panel	Basic price (£)	VAT 20% (£)	MRRP*
<b>BASICS</b>									
Air suspension <sup>(6) (18) (27)</sup>	o	-	-	o	-	-	2,000.00	400.00	£2,400.00
Battery interface	o	o	●	o	o	o	10.00	2.00	£12.00
CAN interface unit	o	-	o	o	o	o	85.00	17.00	£102.00
Digital Tachograph and CAN interface unit <sup>(7)</sup>	o	-	o	o	o	o	650.00	130.00	£780.00
Engine speed limiter (56mph/90kmh OR 62mph/100kmh OR 68mph/110kmh OR 81mph/130kmh) <sup>(8)</sup>	o	-	o	o	o	o	65.00	13.00	£78.00
Fuel tank - 105 litres	o	-	o	o	o	o	100.00	20.00	£120.00
Key - additional (third) key	o	o	o	o	o	o	55.00	11.00	£66.00
Key - 2 button hands free key	o	o	o	o	o	o	250.00	50.00	£300.00
Key - 3 button key	o	o	o	●	●	o	55.00	11.00	£66.00
Locking differential	-	-	-	-	-	o	570.00	114.00	£684.00
Mudflaps (front and rear)	o	o	o	o	o	o	60.00	12.00	£72.00
Power take off - engine <sup>(1) (9)</sup>	o	-	o	-	-	o	130.00	26.00	£156.00
Power take off - gearbox <sup>(10)</sup>	-	-	-	-	-	o	400.00	80.00	£480.00
Rear step	o	o	o	o	o	●	360.00	72.00	£432.00
Reinforced Battery <sup>(11)</sup>	o	●	o	o	o	o	100.00	20.00	£120.00
Smoker pack	o	o	o	o	o	o	20.00	4.00	£24.00
Tyre repair kit (replaces spare wheel)	o	●	o	o	o	-	No cost option		
<b>CONNECTIVITY</b>									
MediaNav Evolution multimedia system: 7" touchscreen, Navteq navigation, FM/AM/DAB tuner, 2x20W speakers, Bluetooth® hands-free calls, USB and AUX sockets, compatible with Apple CarPlay™ and Android Auto™ <sup>(2)</sup>	o	-	o	o	o	o	420.00	84.00	£504.00
<b>COMFORT</b>									
Cruise control with speed limiter	o	o	o	o	o	o	280.00	56.00	£336.00
Driver's seat - fully adjustable suspension type <sup>(13) (24)</sup>	o	o	o	●	o	o	250.00	50.00	£300.00
Electric front windows (driver's side 'one touch' descending)	o	o	o	●	●	o	50.00	10.00	£60.00
Kompo upholstery	o	o	o	-	-	-	50.00	10.00	£60.00
Manual air conditioning with pollen filter	£850	£2,000	£850	●	●	£850	2,000.00	400.00	£2,400.00
Passenger's seat - height-adjustable single seat with armrest	o	o	o	o	o	o	850.00	170.00	£1,020.00
Passenger's seat - height-adjustable with lumbar adjustment single seat <sup>(21)</sup>	o	o	o	o	o	o	60.00	12.00	£72.00
Pivoting seatback table <sup>(13) (22)</sup>	o	o	o	o	o	o	110.00	22.00	£132.00
Pivoting seatback table with dual split underseat storage compartment <sup>(13) (22)</sup>	o	o	●	-	-	o	50.00	10.00	£60.00
Pivoting seatback table with dual split underseat storage compartment <sup>(13) (22)</sup>	o	o	o	●	●	o	200.00	40.00	£240.00
Pollen filter	o	●	o	●	●	o	50.00	10.00	£60.00
Driving pack: Cruise control with speed limiter, Air conditioning with pollen filter, One touch electric front windows	o	-	o	-	-	o	950.00	190.00	£1,140.00
<b>PROTECT</b>									
Airbag - front passenger	o	o	o	o	o	o	235	47	£282.00
Airbag - front passenger, front lateral curtain (driver and passenger) and single passenger seat (height adjustable) with lumbar adjustment <sup>(5)</sup>	o	o	-	o	-	o	800	160	£960.00
Advanced Emergency Braking System <sup>(23)</sup>	o	-	o	o	o	o	490.00	98.00	£588.00
2 Additional anchorage points in loading area, weight allowed per anchorage point: approximately 500kg	o	o	o	o	o	o	75.00	15.00	£90.00
Blind Spot Warning <sup>(20) (26) (29)</sup>	o	-	o	-	-	o	250.00	50.00	£300.00
Bulkhead - full steel with glazing	o	-	-	o	-	o	100.00	20.00	£120.00
LED loadspace lighting	o	o	o	o	o	o	100.00	20.00	£120.00
Rear parking camera with rear parking sensors	o	o	o	o	o	o	550.00	110.00	£660.00
		£550		£330		£550	330.00	80.00	£480.00
Front parking sensors (Inc. rear sensors)	o	o	o	o	o	o	420.00	84.00	£504.00
		£420		£200		£420	200.00		
Front parking sensors (Inc. rear sensors) with rear parking camera	o	o	o	o	o	o	750.00	150.00	£900.00
		£750		£530		£750	530.00		
Parking Pack 1: front & rear parking sensors plus cruise control & wide view mirror	o	-	o	-	-	o <sup>(8)</sup>	570.00	114.00	£684.00
Parking Pack 2: front & rear parking sensors, rear parking camera plus cruise control & wide view mirror	o	-	o	-	-	o <sup>(8)</sup>	900.00	180.00	£1,080.00
Parking Pack 3: front & rear parking sensors plus cruise control, wide view mirror & blind spot warning <sup>(30)</sup>	o	-	o	-	-	o <sup>(8)</sup>	700.00	140.00	£840.00
Parking Pack 4: front & rear parking sensors, rear parking camera plus cruise control, wide view mirror & blind spot warning <sup>(30)</sup>	o	-	o	-	-	o <sup>(8)</sup>	1,000.00	200.00	£1,200.00

	Panel Diesel	Business Panel E-Tech electric	FWD Crew	Business+ Panel	Business+ Crew	RWD Business Panel	Basic price (£)	VAT 20% (£)	MRRP*
Rear parking sensors <sup>(29)</sup>	○	○	○	●	●	○	220.00	44.00	£264.00
Resin coated plywood floor	○	○	○	○	○	○	300.00	60.00	£360.00
Rear View Camera Assist (Does not function when vehicle is reversing)	○	-	○	○	○	○	800.00	160.00	£960.00
Ply lining - full height ply lined side panels and floor - ply lined with resin coating <sup>(3)</sup>	○	-	○	○	○	○	900.00	180.00	£1,080.00
Ply lining - half height ply lined side panels <sup>(6)</sup>	○	○	○	○	○	○	100.00	20.00	£120.00
Towing capacity - twin wheel heavy duty option : Increase to 3,500 Kg <sup>(8)(17)</sup>	-	-	-	-	-	○	350.00	70.00	£420.00
Tyre pressure monitoring system	○	○	○	○	○	-	100.00	20.00	£120.00
Wide view mirror	○	○	○	●	●	○	50.00	10.00	£60.00
4x4 <sup>(4)</sup>	-	-	-	-	-	○	25,000.00	5,000.00	£30,000.00
Lane departure warning system & automatic headlight high/ low beam <sup>(25)(26)(31)</sup>	○	-	○	○	○	○	435.00	87.00	£522.00
<b>STYLE</b>									
16" alloy wheels <sup>(19)</sup>	○	-	○	○	○	-	425.00	85.00	£510.00
16" steel wheels with large wheel stylers <sup>(15)</sup>	○	○	○	●	●	○	50.00	10.00	£60.00
All-weather tyres <sup>(6)(16)</sup>	○	-	○	○	○	○	300.00	60.00	£360.00
Metallic paint	○	○	○	○	○	○	650.00	130.00	£780.00
Tow bar (13-pin plug, 9 wired)	○	-	○	○	○	○	300.00	60.00	£360.00
Front fog lights	○	○	○	○	○	-	160.00	32.00	£192.00
<b>ELECTRIC</b>									
EVSE Cable for 10 amp charging using domestic 3-pin plug	-	○	-	-	-	-	414	82.80	£496.80
My E.V. Connect - 3 year renewal subscription (one year free subscription) <sup>(13)</sup>	-	○	-	-	-	-	64	12.80	£76.80

●= Standard (therefore no cost) ○= Optional - = Not available #Manufacturer's recommended retail prices.

(1) RWD and FWD 135, 150 and 170 versions must be taken with manual air conditioning. (2) For list of compatible Bluetooth devices visit <https://www.renault.co.uk/services/multimedia/bluetooth-compatibility.html> (3) Not available with Glazing Pack or with LML and LHL versions if not twin wheel variant (4) Must be ordered with a locking differential and is not available with Power take off, MediaNav, Lane departure warning, Automatic high-low beam or 4.5T versions. Due to the weight of the 4x4 system selecting this option will reduce your payload. (5) Front lateral airbag covers thorax only (6) Not available on SWB versions (7) Standard on 4.5T and needs to be calibrated by the dealership on hand-over (8) Not available on 4.5T versions (9) Must be taken with battery interface (10) Not available with increase idle speed. Not available on Quickshift (11) Not available on Blue or Quickshift engines (12) Cannot be taken with Airbag - front passenger (13) Not available with front lateral curtain airbag (14) Not available with Power take off - gearbox (15) Not available on twin RWD versions (16) Not compatible with Alloy wheels (17) Only available on Twin RWD versions (18) Requires battery interface and Can interface unit (19) Not available with All-weather tyres (20) Must be ordered with Rear parking sensors (21) Standard on LWB Crew Van Versions (22) Not available on LWB Crew Van Versions: single passenger seat is standard (23) Cannot be ordered with Front parking sensors (24) Not available on 3.1T E-Tech electric versions (25) Must be ordered with Blind Spot Warning on Quickshift engines (26) Not available with MediaNav on Quickshift engines (27) Not compatible with Glazed side loading doors (28) Must be taken with MediaNav multimedia system (29) Standard on 180 QuickShift versions (30) Not available on 180 QuickShift versions (31) Lane Departure Warning standard on 180 QuickShift versions

# Doors, windows and bulkheads pricing

	PANEL	CREW	Basic price (£)	VAT 20% (£)	MRRP*
<b>DOORS, WINDOWS &amp; BULKHEADS</b>					
Right side loading door - unglazed <sup>(4)</sup>	○	-	300	60	£360
Glazing for side loading doors / right hand panel - non-opening windows <sup>(4)</sup>	○	●	150	30	£180
Opening windows in glazed side loading doors <sup>(1)</sup>	○	○	150	30	£180
Rear doors - glazed, 180°	○	○	130	26	£156
Rear doors - glazed 270° <sup>(2)(3)</sup>	○	-	390	78	£468
Rear doors - unglazed, 270° <sup>(2)</sup>	○	○	280	56	£336
Heated Rear Window	○	○	110	22	£132
Glazing pack - Left side loading door - glazed with non opening window, Right side panel - glazed with non opening window, Rear doors - glazed, 180°, Left and right quarter panels - glazed	○	-	390	78	£468

●= Standard (therefore no cost) ○= Optional - = Not available

# Manufacturer's Recommended Retail Price (1) Must be taken with glazed sides (2) Not available on SWB versions (3) Not compatible with door ladder (4) Not compatible with Driver's seat - fully adjustable suspension type

# Master Conversions pricing

## MASTER CONVERSIONS

VERSIONS	WLTP CO <sub>2</sub> (g/km)*	Fuel Type	Combined fuel consumption (mpg)*	Load volume (m <sup>3</sup> )	Max. payload (kg)	VED 2021/22	Basic price (£)	VAT 20% (£)	Total retail price (£)*	On the road price*
<b>CHASSIS CAB SINGLE CAB</b>										
<b>L2H1</b>										
Chassis Cab FWD ML35 ENERGY dCi 145 Business MY22	336	Diesel	22.1	-	1714	£275	£32,230	£6,446	£38,676	£39,706
Chassis Cab RWD ML35 dCi 130 Business MY22	351	Diesel	21.1	-	1601	£275	£33,400	£6,680	£40,080	£41,110
Chassis Cab RWD ML35TW dCi 130 Business MY22	354	Diesel	20.9	-	TBC	£275	£34,400	£6,880	£41,280	£42,310
<b>L2H1 LONG OVERHANG</b>										
Chassis Cab RWD MLL45TW ENERGY dCi 145 Business MY22	tbc	Diesel	tbc	-	2410	£165	£37,750	£7,550	£45,300	£46,220
<b>L3H1</b>										
Chassis Cab FWD LL35 ENERGY dCi 145 Business MY22	336	Diesel	22.1	-	1693	£275	£34,080	£6,816	£40,896	£41,926
Chassis Cab RWD LL35 dCi 130 Business MY22	351	Diesel	21.1	-	1550	£275	£34,200	£6,840	£41,040	£42,070
<b>L3H1 LONG OVERHANG</b>										
Chassis Cab RWD LLL35TW ENERGY dCi 145 Business MY22	359	Diesel	20.6	-	1405	£275	£37,050	£7,410	£44,460	£45,490
<b>CHASSIS CAB DOUBLE CAB</b>										
<b>L3H1</b>										
Chassis Double Cab FWD LL35 ENERGY dCi 145 Business MY22	336	Diesel	22.1	-	1521	£275	£35,330	£7,066	£42,396	£43,426
<b>L3H1 LONG OVERHANG</b>										
Chassis Double Cab RWD MLL35TW ENERGY dCi 145 Business MY22	359	Diesel	20.6	-	TBC	£275	£37,500	£7,500	£45,000	£46,030
<b>PLATFORM CAB</b>										
<b>L3H1</b>										
Platform Cab FWD LL35 ENERGY dCi 145 Business MY22	336	Diesel	22.1	-	1775	£275	£34,380	£6,876	£41,256	£42,286
<b>DROPSIDE SINGLE CAB</b>										
<b>L2H1 (REAR CORNER PILLARS)</b>										
Chassis Cab Dropside (incl. Rear Corner Pillars) FWD ML35 ENERGY dCi 145 Business MY22	336	Diesel	22.1	-	1399	£275	£35,330	£7,066	£42,396	£43,426
<b>L3H1 (REAR CORNER PILLARS)</b>										
Chassis Cab Dropside (incl. Rear Corner Pillars) FWD LL35 ENERGY dCi 145 Business MY22	336	Diesel	22.1	-	1333	£275	£37,180	£7,436	£44,616	£45,646
Chassis Cab Dropside (incl. Rear Corner Pillars) RWD LL35 dCi 130 Business MY22	351	Diesel	21.1	-	1190	£275	£37,300	£7,460	£44,760	£45,790
<b>L3H1 LONG OVERHANG (REAR CORNER PILLARS)</b>										
Chassis Cab Dropside (incl. Rear Corner Pillars) RWD LLL35TW ENERGY dCi 145 Business MY22	359	Diesel	20.6	-	945	£275	£40,150	£8,030	£48,180	£49,210
<b>L2H1 (TAIL LIFT)</b>										
Chassis Cab Dropside (incl. Tail Lift) FWD ML35 ENERGY dCi 145 Business MY22	336	Diesel	22.1	-	1234	£275	£40,330	£8,066	£48,396	£49,426
<b>L3H1 (TAIL LIFT)</b>										
Chassis Cab Dropside (incl. Tail Lift) FWD LL35 ENERGY dCi 145 Business MY22	336	Diesel	22.1	-	1168	£275	£42,180	£8,436	£50,616	£51,646
Chassis Cab Dropside (incl. Tail Lift) RWD LL35 dCi 130 Business MY22	351	Diesel	21.1	-	1025	£275	£42,300	£8,460	£50,760	£51,790
<b>L3H1 LONG OVERHANG (TAIL LIFT)</b>										
Chassis Cab Dropside (incl. Tail Lift) RWD LLL35TW ENERGY dCi 145 Business MY22	359	Diesel	20.6	-	780	£275	£45,150	£9,030	£54,180	£55,210
<b>DROPSIDE DOUBLE CAB</b>										
<b>L3H1 (REAR CORNER PILLARS)</b>										
Chassis Double Cab Dropside (incl. Rear Corner Pillars) FWD LL35 ENERGY dCi 145 Business MY22	336	Diesel	22.1	-	1206	£275	£38,430	£7,686	£46,116	£47,146
<b>L3H1 (TAIL LIFT)</b>										
Chassis Double Cab Dropside (incl. Tail Lift) FWD LL35 ENERGY dCi 145 Business MY22	336	Diesel	22.1	-	1041	£275	£43,430	£8,686	£52,116	£53,146
<b>TIPPER SINGLE CAB</b>										
<b>L2H1</b>										
Tipper Single Cab FWD ML35 ENERGY dCi 145 Business MY22	336	Diesel	22.1	-	1217	£275	£36,230	£7,246	£43,476	£44,506
Tipper Single Cab RWD ML35 dCi 130 Business MY22	351	Diesel	21.1	-	1104	£275	£37,400	£7,480	£44,880	£45,910
Tipper Single Cab RWD ML35TW dCi 130 Business MY22	tbc	Diesel	tbc	-	934	£275	£38,400	£7,680	£46,080	£47,110
<b>TIPPER DOUBLE CAB</b>										
<b>L3H1</b>										
Tipper Double Cab RWD LL35 ENERGY dCi 145 Business MY22	tbc	Diesel	tbc	-	890	£275	£40,500	£8,100	£48,600	£49,630
<b>L2H1 LONG OVERHANG</b>										
Tipper Double Cab RWD MLL35TW dCi 130 Business MY22	tbc	Diesel	tbc	-	825	£275	£41,250	£8,250	£49,500	£50,530
<b>ALUMINIUM TIPPER SINGLE CAB</b>										
<b>L2H1</b>										
Aluminium Tipper Single Cab FWD ML35 ENERGY dCi 145 Business MY22	336	Diesel	22.1	-	1314	£275	£37,730	£7,546	£45,276	£46,306
Aluminium Tipper Single Cab RWD ML35 dCi 130 Business MY22	351	Diesel	21.1	-	1201	£275	£38,900	£7,780	£46,680	£47,710
Aluminium Tipper Single Cab RWD ML35TW dCi 130 Business MY22	354	Diesel	20.9	-	1020	£275	£39,900	£7,980	£47,880	£48,910
<b>ALUMINIUM TIPPER DOUBLE CAB</b>										
<b>L3H1</b>										
Aluminium Tipper Double Cab RWD LL35 dCi 130 Business MY22	351	Diesel	21.1	-	953	£275	£40,950	£8,190	£49,140	£50,170
Aluminium Tipper Double Cab RWD LL35TW ENERGY dCi 145 Business MY22	359	Diesel	20.6	-	808	£275	£43,800	£8,760	£52,560	£53,590



## MASTER CONVERSIONS

VERSIONS	WLTP CO <sub>2</sub> (g/km) <sup>†</sup>	Fuel Type	Combined fuel consumption (mpg) <sup>†</sup>	Load volume (m <sup>3</sup> )	Max. payload (kg)	VED 2021/22	Basic price (£)	VAT 20% (£)	Total retail price (£)*	On the road price*
<b>LUTON LOW LOADER</b>										
L3H1										
Luton Low Loader FWD LL35 ENERGY dCi 145 Business MY22	336	Diesel	22.1	19.0	1238	£275	£43,080	£8,616	£51,696	£52,726
<b>LUTON BOX VAN</b>										
L3H1										
Luton Box Van 20M <sup>3</sup> FWD LL35 ENERGY dCi 145 Business MY22	336	Diesel	22.1	20.0	1204	£275	£38,280	£7,656	£45,936	£46,966
Luton Box Van 20M <sup>3</sup> RWD LL35 dCi 130 Business MY22	351	Diesel	21.1	20.0	1061	£275	£39,450	£7,890	£47,340	£48,370
<b>L3H1 (TAIL LIFT)</b>										
Luton Box Van 20M3 (incl. Tail Lift) FWD LL35 ENERGY dCi 145 Business MY22	336	Diesel	22.1	20.0	1064	£275	£42,030	£8,406	£50,436	£51,466
Luton Box Van 20M3 (incl. Tail Lift) RWD LL35 dCi 130 Business MY22	351	Diesel	21.1	20.0	921	£275	£43,200	£8,640	£51,840	£52,870

## MASTER E-TECH ELECTRIC CONVERSIONS - BATTERY FULL PURCHASE

VERSIONS	WLTP CO <sub>2</sub> (g/km) <sup>†</sup>	Power Unit Output kW (bhp)	Load volume (m <sup>3</sup> )	Max. payload (kg)	Basic Price (£)	VAT 20% (£)	Total Retail (£)*	Government Grant (£)	Basic Price after PiVG** exc VAT	Total Retail Price after PiVG***	On The Road Price after PiVG****
<b>L3H1 PLATFORM CAB</b>											
Platform Cab FWD LL31 E-Tech Business MY21	0	57 (76)	-	1305	tbc	tbc	tbc	tbc	tbc	tbc	tbc
Platform Cab FWD LL35 E-Tech Business MY21	0	57 (76)	-	1720	tbc	tbc	tbc	tbc	tbc	tbc	tbc
<b>L3H1 LUTON LOW LOADER</b>											
Luton Low Loader FWD LL31 E-Tech Business MY21	0	57 (76)	19	768	tbc	tbc	tbc	tbc	tbc	tbc	tbc
Luton Low Loader FWD LL35 E-Tech Business MY21	0	57 (76)	19	1183	tbc	tbc	tbc	tbc	tbc	tbc	tbc
<b>L2H1 CHASSIS CAB</b>											
Chassis Cab FWD ML35 E-Tech Business MY21	0	57 (76)	-	1620	tbc	tbc	tbc	tbc	tbc	tbc	tbc
<b>L3H1 CHASSIS CAB</b>											
Chassis Cab FWD LL35 E-Tech Business MY21	0	57 (76)	-	1600	tbc	tbc	tbc	tbc	tbc	tbc	tbc

\*All prices shown are the manufacturer's recommended retail prices. The "On The Road" Price Includes delivery to the dealer premises, number plates and a four-litre AdBlue® starter kit, 12 months government road fund licence at £275 (or £165 for vans with a GVW of more than 3.5 tonnes) and First Registration Fee at £55. Other goods or services supplied by agreement between the customer and the Dealer are not included. No CO<sub>2</sub> or MPG data published for base Platform Cab as the final kerb weight of the vehicle is not defined until the body is fitted. \*\* PiVG - Plug In Van Grant \*\*\* All prices shown are the manufacturer's recommended retail prices. † - Indicates with full battery purchase. \*\*\*\*On the road Price is less expensive than the total retail price due to the PiVG Government Grant. To benefit from PiVG for incomplete vehicles, the 3rd party converter must register for PiVG. ^Payload equals the Maximum Operating Mass (Gross Vehicle Mass or GVW) less the Kerb Mass. Kerb Mass is the weight of the complete vehicle including coolant, oil, a 90% full fuel tank, a 100% full AdBlue® tank, spare wheel and jack, but excluding driver and crew. All Kerb Masses, and therefore Payloads quoted are subject to a 5% manufacturing tolerance and are based on the base level model. Any additional equipment added (options or accessories), or the selection of a higher trim level, could result in a higher Kerb Mass and a reduced Payload, and may increase CO<sub>2</sub> and decrease MPG figures. † WLTP figures shown are for comparability purposes; only compare figures with vehicles tested to the same technical procedures. Actual real world driving results may vary depending on factors such as weather conditions, driving styles, vehicle load or any accessories fitted after registration. WLTP is a new test used for fuel consumption and CO<sub>2</sub> figures. Please visit [renault.co.uk/configure](http://renault.co.uk/configure) for WLTP figures for any selected options.

### LCV SERVICE PLAN

5 Years / 66,000 miles

**MRRP (inc VAT)**

£700

5 Years / 66,000 miles - Master E-Tech electric

£750

### LCV EXTENDED WARRANTY

5 Years / 100,000 miles

**MRRP (inc VAT)**

£785

5 Years / 96,000 miles - Master E-Tech electric

£630

**Service Plan Terms & Conditions** The Service Plan offer is available on all LCV's. Valid at participating Renault dealers only and may be purchased up to 12 months after registration or before the first service (whichever is sooner). Vehicles must be ordered between 01 December 2021 and 31 March 2022 and registered by 30 June 2022.

The Renault Service plan covers the manufacturer's minimum maintenance programme requirements for the term of the Service Plan purchased (refer to the Warranty and Service sheet in the Handover Document wallet for details). The plan ends when you reach the age or mileage limit (whichever comes first). Services must be carried out in line with the manufacturer's minimum maintenance programme requirements and servicing intervals within +/- 1 month or 1,000 miles of the service interval and can only be carried out at a Renault Approved outlet. Service plans do not cover wear and tear items such as (but not limited to) tyres, wiper blades or brakes. For Service plan full Terms & Conditions visit [www.renault.co.uk/owners](http://www.renault.co.uk/owners). Cannot be part exchanged, refunded or transferred. All prices quoted are MRRP.

**Extended Warranty Terms & Conditions** The Extended Warranties are available on all LCV's (excluding ZOE Van). Valid at participating Renault dealers only and are available to purchase from first date of registration and may be purchased up to 12 months after registration. For full Extended Warranty Terms and Conditions visit [www.renault.co.uk/extensions-of-warranties](http://www.renault.co.uk/extensions-of-warranties)

# Master Conversions options pricing

	CHASSIS				PLATFORM		DROPSIDE				TIPPER			LUTON LOW LOADER		LUTON BOX VAN		Basic price (£)	VAT 20% (£)	MRRP*
	SINGLE CAB		DOUBLE CAB		SINGLE CAB		SINGLE CAB		DOUBLE CAB		SINGLE CAB		DOUBLE CAB	LUTON LOW LOADER		LUTON BOX VAN				
	FWD	RWD	E-Tech electric	FWD	FWD	E-Tech electric	FWD	RWD	FWD	RWD	FWD	RWD	RWD	FWD	E-Tech electric	FWD	RWD			
<b>BASICS</b>																				
Air suspension <sup>(16)</sup> (20)	o	-	-	o	o	-	o	-	o	-	o	-	-	o	-	o	-	2,000	400	£2,400
B-pillar wiring connection point <sup>(6)</sup>	o	o	o	-	o	o	o	-	o	-	o	-	-	●	o	-	-	60	12	£72
Battery interface	o	o	-	o	o	-	●	●	●	●	●	●	●	o	-	o	o	10	2	£12
CAN interface unit	o	o	-	o	o	-	o	o	o	o	o	o	o	o	-	o	o	85	17	£102
Digital tachograph and CAN interface unit <sup>(5)</sup>	o	o	-	o	o	-	o	o	o	o	o	o	o	o	-	o	o	650	130	£780
Engine speed limiter - 56mph/90kmh (to meet legal requirement) <sup>(5)</sup>	o	o	-	o	o	-	o	o	o	o	o	o	o	o	-	o	o	60	12	£72
Engine speed limiter (56mph/90kmh or 62mph/100kmh or 68mph/110kmh) <sup>(6)</sup>	o	o	-	o	o	-	o	o	o	o	o	o	o	o	-	o	o	65	13	£78
Fuel tank - 105 litres <sup>(7)</sup>	o	o	-	o	o	-	o	o	o	o	o	o	o	o	-	o <sup>(11)</sup>	o <sup>(11)</sup>	100	20	£120
Key - 2 button hands free key	o	o	o	o	o	o	o	o	o	o	o	o	o	o	o	o	o	250	50	£300
Key - additional (third) key	o	o	o	o	o	o	o	o	o	o	o	o	o	o	o	o	o	55	11	£66
Locking differential <sup>(17)</sup>	-	o	-	-	-	-	o	-	o	-	o	-	o	-	-	-	o	570	114	£684
Long wiring loom	o	o	-	o	o	-	-	-	-	o	o	o	o	o	-	-	-	15	3	£18
Power take off - engine	-	-	-	-	-	-	-	-	-	o	-	-	-	-	-	-	-	120	24	£144
Power take off - engine, and manual air conditioning with pollen filter <sup>(8)</sup> (9)	-	o	-	-	-	-	o	o	-	o	o	o	o	-	-	-	o	920	184	£1,104
Power take off - engine, battery interface and air conditioning with pollen filter <sup>(8)</sup> (9)	o	-	-	o	o	-	-	-	-	-	-	-	-	o	-	o	-	930	186	£1,116
Power take off - engine and converter pack 1 <sup>(3)</sup> (8)(9)(18)(19)	o	o	-	-	o	-	-	-	-	-	-	-	-	-	-	-	-	205	41	£246
Power take off - engine and converter pack 2 <sup>(3)</sup> (8)(9)(18)	o	o	-	o	o	-	-	-	-	-	-	-	-	o	-	-	-	145	29	£174
Power take off - gearbox <sup>(8)</sup> (9)(11)(17)	-	o	-	-	-	-	o	-	o	-	o	-	o	-	-	-	o	400	80	£480
Reinforced battery <sup>(9)</sup> (12)(23)	o	o	●	o	o	●	o	o	o	o	o	o	o	o	●	o	o	100	20	£120
Smoker pack	o	o	o	o	o	o	o	o	o	o	o	o	o	o	o	o	o	12	2.40	£14.40
Towing twin wheel heavy duty option: increase to 3,500 Kg <sup>(6)</sup> (9)(10)	-	o	-	-	-	-	o	-	o	-	o	-	o	-	-	-	o	350	70	£420
Tyre repair kit (replaces spare wheel)	o	-	●	o	o	●	o	-	o	-	o	-	-	-	o	●	-	No cost option		
Converter pack 1: Battery interface, B pillar wiring connection point, long wiring loom	o	o	-	-	o <sup>(23)</sup>	-	-	-	-	-	-	-	-	o <sup>(23)</sup>	-	o	-	85	17	£102
Converter pack 2: CAN interface unit, battery interface, long wiring loom	o	o	-	o	o	-	-	-	-	-	-	-	-	o	-	o	-	100	20	£120
Converter pack 3: CAN interface unit, battery interface, B pillar wiring connection point, long wiring loom	o	o	-	-	o <sup>(23)</sup>	-	-	-	-	-	-	-	-	o <sup>(23)</sup>	-	o	-	160	32	£192
<b>CONNECTIVITY</b>																				
MediaNav Evolution multimedia system: 7" touchscreen, Navteq navigation, FM/AM/DAB tuner, 2x20W speakers, Bluetooth® hands-free calls, USB and AUX sockets, compatible with Apple CarPlay™ and Android Auto™ <sup>(2)</sup>	o	o	-	o	o	-	o	o	o	o	o	o	o	o	-	o	o	420	84	£504
<b>COMFORT</b>																				
Cruise control with speed limiter	o	o	o	o	o	o	o	o	o	o	o	o	o	o	o	o	o	280	56	£336
Driver's seat - fully adjustable suspension type <sup>(13)</sup> (24)	o	o	o	o	o	o	o	o	o	o	o	o	o	o	o	o	o	250	50	£300
Electric front windows - driver's side one-touch descending	o	o	o	o	o	o	o	o	o	o	o	o	o	o	o	o	o	50	10	£60
Manual air conditioning with pollen filter																		850	170	£1,020
	£850	£2,000		£850	£2,000					£850				£2,000		£850	2,000	400	£2,400	
Passenger's seat - height-adjustable with lumbar adjustment single seat	o	o	o	o	o	o	o	o	o	o	o	o	o	o	o	o	o	110	22	£132
Passenger's seat - height-adjustable single seat <sup>(14)</sup>	o	o	o	o	o	o	o	o	o	o	o	o	o	o	o	o	o	60	12	£72
Pivoting seatback table <sup>(15)</sup>	o	o	o	o	o	o	o	o	o	o	o	o	o	o	o	o	o	50	10	£60
Pivoting seatback table with dual split underseat storage compartment <sup>(15)</sup>	o	o	o	o	o	o	o	o	o	o	o	o	-	o	o	o	o	80	16	£96
Pollen filter	o	o	o	o	o	o	o	o	o	o	o	o	o	o	o	o	o	50	10	£60
Driving Pack: Manual air conditioning with pollen filter, Electric front windows - driver's side one-touch descending, Cruise control with speed limiter	o	o	-	o	o	-	o	o	o	o	o	o	o	o	-	o	o	950	190	£1,140
<b>PROTECT</b>																				
Airbag - front passenger	o	o	o	o	o	o	o	o	o	o	o	o	o	o	o	o	o	235	47	£282
Airbag - front passenger and front lateral curtain (driver and passenger), and single passenger seat (height adjustable) with lumbar adjustment	o	o	o	o	o	o	o	o	o	o	o	o	o	o	o	o	o	800	160	£960
Advanced emergency braking system <sup>(25)</sup>	o	o	-	o	o	-	o	o	o	o	o	o	o	o	-	o	o	490	98	£588
Automatic high/low beam and front fog lights (4.5T versions only)	-	o	-	-	-	-	-	-	-	-	-	-	-	-	-	-	-	350	70	£420
Front fog lights	o	o	o	o	o	o	o	o	o	o	o	o	o	o	o	o	o	160	32	£192
Wide view mirror	o	o	o	o	o	o	o	o	o	o	o	o	o	o	o	o	o	50	10	£60
4x4 <sup>(4)</sup>	-	o	-	-	-	-	-	o	-	o	-	o	-	-	-	-	-	25,000	5,000	£30,000

STYLE	CHASSIS				PLATFORM		DROPSIDE				TIPPER			LUTON LOW LOADER		LUTON BOX VAN		Basic price (£)	VAT 20% (£)	MRRP*
	SINGLE CAB		DOUBLE CAB		SINGLE CAB		SINGLE CAB	DOUBLE CAB		SINGLE CAB	DOUBLE CAB		FWD	E-Tech electric	FWD	RWD				
	FWD	RWD	E-Tech electric	FWD	FWD	E-Tech electric	FWD	RWD	FWD	RWD	FWD	RWD	RWD	FWD	E-Tech electric	FWD	RWD			
16" alloy wheels <sup>(16)(24)</sup>	o	-	-	o	o	-	o	-	o	-	o	-	-	o	-	o	-	425	85	£510
16" steel wheels with large wheel stylers <sup>(12)</sup>	o	o	o	o	o	o	o	o	o	o	o	o	o	o	o	o	o	50	10	£60
All-weather tyres <sup>(16)</sup>	o	o	-	o	o	-	o	o	o	o	o	o	o	o	-	o	o	215	43	£258
Dropside - tool compartment and ladder rack <sup>(21)(22)</sup>	-	-	-	-	-	-	o	o	o	o	-	-	-	-	-	-	-	200	40	£240
Extended door mirror arms	o	o	o	o	o	o	o	o	o	o	o	o	o	o	o	o	o	50	10	£60
Metallic paint <sup>(1)</sup>	o	o	o	o	o	o	o	o	o	o	o	o	o	o	o	o	o	650	130	£780
Mudflaps (front and rear)	o	o	o	o	o	o	o	o	o	o	o	o	o	o	o	o	o	60	12	£72
Tow bar (13-pin plug, 9 wired) <sup>(7)</sup>	o	o	-	o	o	-	o	o	o	o	o	o	-	o	-	o	o	300	60	£360
<b>ELECTRIC</b>																				
EVSE Cable for 10 amp charging using domestic 3-pin plug	-	-	o	-	-	o	-	-	-	-	-	-	-	-	o	-	-	414	82.80	£496.80
Type 2 Mennekes charging cable 32A (IEC - 629196) 6m	-	-	o	-	-	o	-	-	-	-	-	-	-	-	o	-	-	75	15	£90

● = Standard (therefore no cost) o = Optional - = Not available #Manufacturer's recommended retail prices.

(1) On the Box Van and Luton Low Loader versions, only the base chassis is painted. The box will remain white. If your box is required to be painted, please contact your local dealer to get a quote. (2) For list of compatible Bluetooth devices visit <https://www.renault.co.uk/services/multimedia/bluetooth-compatibility.html> (3) On FWD 135, 150 and 180 versions must be ordered with air conditioning. Not available on Quickshift engines. (4) Not available on twin wheel Double Cab or Steel Tipper versions. Must be ordered with a locking differential and is not available with Power take off, MediaNav, Lane departure warning, Automatic high-low beam or 4.5T versions. Due to the weight of the 4x4 system selecting this option will reduce your payload. (5) Standard on 4.5T versions and the digital tachograph needs to be calibrated by the dealership on hand-over (6) Not available on 4.5T versions (7) Not available on Factory Steel Tipper (8) Increase idle speed and Power take off - gearbox cannot be ordered together (9) Not available on Quickshift versions (10) Only available on Twin RWD Versions (11) Not compatible with ECO Mode and Increased idle speed (12) Not available on twin RWD versions (13) Cannot be ordered with front passenger airbag or front lateral curtain airbag (14) Standard on Double Cab Factory Tipper and LWB Twin Rear Wheel Dropsides. Still optional on Aluminium Tippers (15) Cannot be ordered with Front lateral curtain airbag (16) Not available on RWD (17) Not available on FWD (18) Requires to be taken with Long wiring loom and Battery interface (19) Requires to be taken with B-Pillar wiring connect point (20) Requires Battery Interface and CAN Interface Unit (21) Not compatible with Air suspension (22) Requires Battery interface (23) Not compatible with Start & Stop Blue engines (24) Not compatible with All-weather tyres (25) Cannot be ordered with Front parking sensors (26) Not available on 3.1T E-Tech electric versions (27) Must be taken with MediaNav multimedia system

# Accessories

---



**1. Roof bars:** Very practical for transporting professional equipment and all other bulky loads. These roof bars meet all safety and quality standards and are available in either a set of 2 bar (maximum load: 89.5kg) or 4 bars (maximum load: 181.5kg).

**2. Rubber floor mats:** These waterproof and easy-to-maintain mats ensure total protection for the floor of your Master. They are quick to attach using 2 safety clips and come in packs of 2 or 4.

**3. Loading pack\*:** Essential for easy access to the roof. Pack includes the steel ladder, mounted inside the door for a better hold, and the aluminium roof rack, supplied with rear roller for easy loading.

**4. Kenwood Dashcam:** The Kenwood DVR-A501W dashcam is a great addition for added security and reassurance on the road. The on-board camera automatically starts recording as soon as the vehicle ignition is switched on. The dashcam is designed to give drivers peace of mind, as video footage is widely accepted and used for insurance claims. The pack includes a GPS integrated dashboard camera, touch panel control and parking mode recording.

**5. Sortimo racking:** Ready4Work and SR5 ranges. Pre-selected and bespoke racking solutions available giving you more room & more space for what matters.

\*All accessories are available to order individually.

Some accessories require the vehicle to be registered before fitment. Your local dealer will be able to offer further advice and supply a dealer fitted price for vehicles already in dealer stock. Accessories are fitted post production and may have an impact on real world fuel (actual) consumption and CO<sub>2</sub> figures.

For more information and additional accessories, consult the Master accessories brochure.

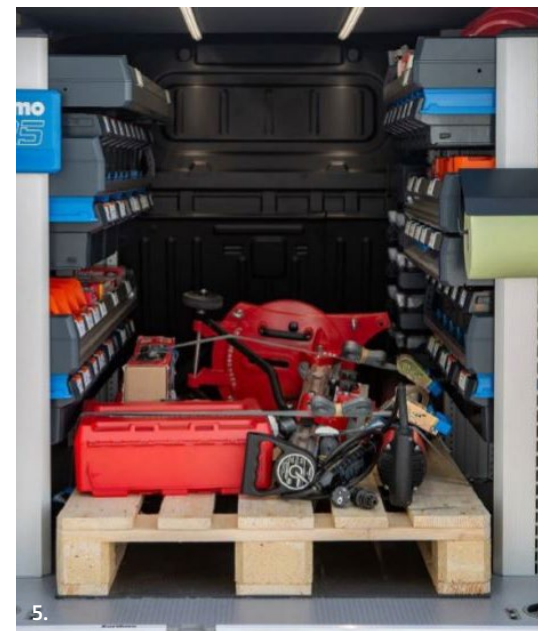

# Master accessory pricing

	Basic price (£)	MRRP*
<b>CHEVRONS</b>		
Master 60 full rear chevron (medium roof)	400	£480
Master full rear chevron (medium roof)	375	£485
Master without window (medium roof)	350	£420
Window only	225	£270
Lower half height	225	£270
1/4 Height	200	£240
<b>PROTECTION</b>		
Technology pack - reversing camera and alarm	433.33	£500
Ply lining - Master SWB	174.17	£209
Ply lining - Master MWB	190.83	£229
Ply lining - Master MWB crew van	199.17	£239
Ply lining - Master LWB	190.83	£229
Ply lining - Master LWB crew van	232.50	£279
Rear body coloured parking sensors	240	£288
Textile mats	33.33	£40
Rubber mats	54.17	£60
Rear protective window grills	104.17	£125
Reversing camera and screen	257.50	£310
Heavy duty seat covers in black, front seats	108.33	£130
<b>TRANSPORT &amp; TOWING</b>		
Loading pack L2H2	750	£900
Loading pack L3H2	812.50	£1,070
Loading pack L4H2	966.67	£1,159
Aluminium walkway - L2	275	£340
Aluminium walkway - L3	275	£320
Aluminium walkway - L4	275	£276
Transversal roof bars	216.67	£260
Towing pack FWD	370	£445
Towing pack RWD	395	£475
Towing pack RWD twin wheels	390.83	£470
<b>SORTIMO RACKING</b>		
Ready 4 Work range - pre-selected and bespoke packages		Ask for a personalised quote
SR5 range - pre-selected & bespoke packages		Ask for a personalised quote
<b>SAFETY</b>		
Master rear step	368.33	£442
Master rear step with sensors	458.33	£550
Deadlock kit-front door	150	£180
Deadlock kit-passenger front door	150	£180
Deadlock kit-sideloadng door	150	£180
Deadlock kit-passenger sideloadng door	150	£180
Deadlock kit-rear door	150	£180
Obd port protector-kit	200	£240
Deadlock 4 door set-driver,passenger,side loading, rear barn	408.33	£490
Deadlock 2 door set-side loading, rear barn	266.67	£320
Slamlock 2 door set-side loading, rear barn	266.67	£320
Protektaplate 4 door set-driver,passenger, side loading, rear barn	400	£480
Protektaplate 2 door set-side loading, rear barn	250	£300
Armourshell 2 door standard set- side loading, rear barn - black	400	£480
Catalytic converter protector fwd	125.83	£151
Alarm - Thatcham Category 1	200	£240
Kenwood dashcam	208.33	£245

\* Manufacturer's Recommended Retail Price, prices include parts and fitting, accessory prices shown are only valid for vehicles which will have the accessories fitted at the manufacturers import centre. Your local dealer will be able to offer further advice and supply a dealer fitted price for vehicles already in dealer stock. Accessories are fitted post-production, and may have an impact on real world fuel (actual) consumption and CO<sub>2</sub> figures.

# Further information

Vehicle	Classed As	Delivery to Dealer and Number Plates*	Vehicle Excise Duty	First Registration Fee	Total
Master Van	LCV	£636	£275	£55	£966
Master 4.5t versions	HGV	£636	£165	£55	£856

Information correct at time of publication \* Inc VAT † WLTP figures shown are for comparability purposes; only compare figures with vehicles tested to the same technical procedures. Actual real world driving results may vary depending on factors such as weather conditions, driving styles, vehicle load or any accessories fitted after registration. WLTP is a new test used for fuel consumption and CO2 figures. Please visit [renault.co.uk/configure](http://renault.co.uk/configure) for WLTP figures for any selected options.

## Renault Pro+, the specialist brand



You're the expert in your field and at Renault Pro+ we're here to guide you through ours. We're passionate about delivering products and services to move your business forward. So when you choose to partner with Renault Pro+ you can expect:

### Specialist network

Renault Pro+ Centres have a dedicated commercial vehicle specialist. So whatever you're seeking advice on, there's always someone to help.

### Business Commitment

Come rain or shine, we have a set of commitments in place to help maximise uptime and minimise downtime.

### The future today - 100% electric

Renault Pro+ has been building, selling and maintaining electric vans since 2011. So when you're looking to make the switch, you know who to speak to.

### A tailored approach

Your vehicles are as unique as your business. That's why we have a programme of conversions to deliver exactly the product you want. From 'off the shelf' conversions to a more bespoke approach. We'll guide you through.

# Renault services

## 3 Years Warranty

Your vehicle is covered by a warranty package for up to 3 years from date of first registration (unlimited mileage during the first 24 months, followed by a further 1 year limited to a total mileage of 100,000). Your Renault Dealer is able to repair or replace without charge, parts that are found to have a material or assembly defect that is recognised by Renault. The paintwork warranty runs for 3 years and the anti-corrosion warranty for 6 years.

For Warranty Terms and Conditions please visit [www.renault.co.uk/warranty](http://www.renault.co.uk/warranty).

## 3 Years Renault Assistance

Should you need it, we'll provide emergency roadside repairs or tow you to the nearest Renault Dealer. This service is available 24 hours a day and is provided for 36 months from the date of first registration (unlimited mileage for first 24 months, then limited to a total of 100,000 miles or 3 years, whichever comes first). Assistance is provided within the UK & Northern Ireland only at roadside, home and includes national recovery and onward travel. Assistance applies to mechanical or electrical defects which are covered by warranty.

For Renault Assistance Terms and Conditions please visit [www.renault.co.uk/assistance](http://www.renault.co.uk/assistance).

## LCV Service Plans & Extended Warranties

Renault's LCV Service Plans are the ultimate package to provide care free servicing for your new Renault LCV.

It really is the hassle free way to take care of your Renault and benefits from;

- Inflation Proof Servicing - You know exactly what you'll pay and there are no hidden costs
- Peace of Mind - No matter where life takes you, we'll be there in over 5000 workshops across Europe
- Renault Expertise & Quality - Our highly trained technicians know your Renault inside out

The Renault LCV Service Plan contains Renault services in-line with the manufacturer's service schedule, plus comes with a complimentary vehicle safety check to ensure your Renault is in the best condition possible.

Renault LCV Extended Warranty enhancements also available. Refer to the Price Guide for more details.

## Service Intervals

Master E-Tech electric Service: Year 1 / 12,000 miles, Year 2 / 24,000 miles and then every 2 years / 24,000 miles thereafter

Master all other engines and versions: 24,000 miles / 2 years

## Renault Network Services

No-one is better placed than Renault to maintain, fit and repair your Renault, fast. The Renault Minute (maintenance and repair with no appointment necessary) and Renault Rapide Bodycare (bumper scuffs, dings and dents, windscreen, stone chips and interior repairs...) services deliver the highest level of repair and maintenance and offer a full year's guarantee on original Renault parts. Don't forget to have a look at our wide range of additional equipment and accessories!

## Renault iCare

Is an innovative Service, Maintenance & Repair product that supplies Business customers with a fully supported, managed hassle free service and maintenance package.

Renault iCare is a "Pay-As-You-Go" product that insures your vehicle is maintained by Renault technical experts when work is required.

iCare provides the following benefits:

- Full Service, Maintenance & Repair cover in the Renault Dealer Network
  - Tyres can be included within the contract at an additional fixed cost
  - Ancillary equipment can also be included (at an additional fixed monthly cost)
  - Excludes: Damage/Neglect/Abuse/Glass & Bulbs
- A fixed, pre agreed pence per mile rate
- No excess mileage charges at the end of the contract
- No pooled mileage administration
- Minimalise downtime

For more information and to obtain a quote based on your requirements, please speak to your local Renault Business dealer or visit [www.renault.co.uk/icare](http://www.renault.co.uk/icare)

## Customer Relations

Renault knows the value of communicating with its customers and we have established effective ways to keep in touch with you. If, after speaking to your local Renault dealership, you are not completely satisfied, please contact the Renault UK Customer Relations Team on 0344 3350000\* (Mon-Fri 8.00am to 6.00pm, Closed on Bank Holidays. Live Chat Mon-Fri 8.00am to 9.00pm). You can also visit our website [www.renault.co.uk](http://www.renault.co.uk) or write to us at: Renault UK Ltd, The Rivers Office Park, Denham Way, Maple Cross, Rickmansworth, Hertfordshire, WD3 9YS.

## Finance options\*

There are numerous ways that you can finance your new vehicle with Renault. Whether you are a fleet or a private buyer, Renault Finance allows you to tailor your payment plan to your needs and circumstances.





Continue the Renault **Master** experience  
at [www.renault.co.uk](http://www.renault.co.uk)



Although every effort has been made to ensure that the information contained within this brochure is as accurate and up to date as possible, Renault U.K. reserves the right to modify its models without notice, including their characteristics, specifications, equipment and accessories. Brochures inevitably become out of date or inaccurate in some respects, in that such characteristics, specifications equipment, or accessories may be changed after the publication date given below and can differ from the descriptions given or the photos displayed. It is therefore necessary to check with your Renault Dealer before purchasing any product that the characteristics, specifications, equipment or accessories of the vehicle on order are as advertised.

Renault recommends 

Prodigious Photo credits: J.B. Lemal, P. Curtet, T. Motta, W. Crozes - Mathématique - © Renault Marketing 3D - Commerce - 7701 380 809 - March 2022.