

THE ART OF AUTOMOTIVE EXCELLENCE

 **HONDA**





PRELUDE – A PROMISE

The promise of Honda Prelude is a simple one – it offers the discerning motorist a unique and pleasurable driving experience. An experience which will be enjoyed for many years to come.

A simple promise perhaps but one only made possible by the enormous technological achievements embodied in new Honda Prelude.

From any angle, Prelude is a dynamic, forceful looking vehicle but it also has the understated elegance of a luxury sedan, with smooth, flowing lines that put it in the forefront of style and aerodynamic efficiency.

Immense care has been taken to ensure that the external areas of the body are free from unnecessary protrusions that generate noise and reduce efficiency. Even the huge single windscreen wiper has been concealed below the air-flow line of the bonnet.

Prelude is typically Honda in attention to detail too.

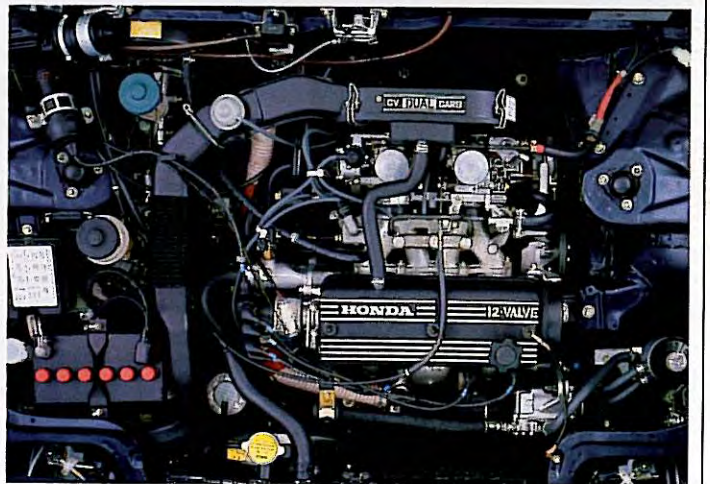
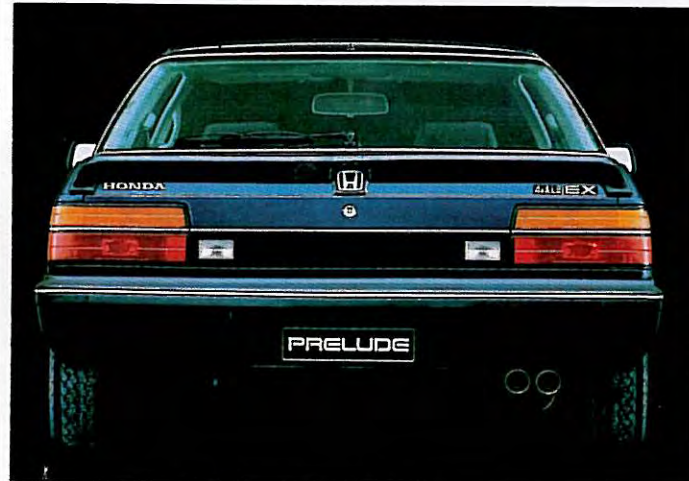
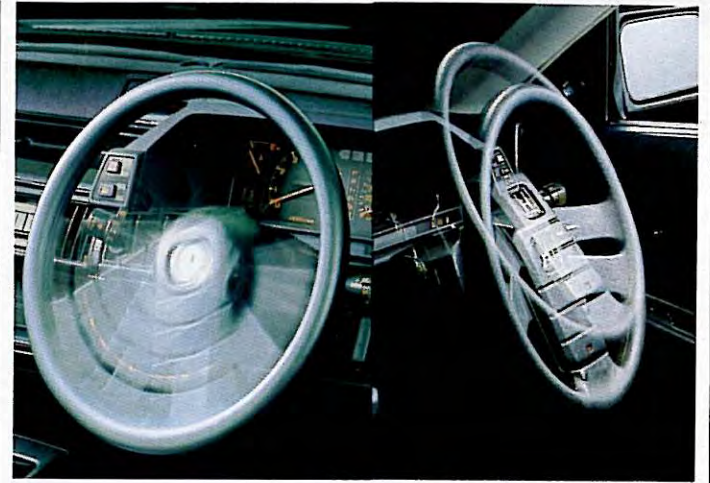



HONDA

ACCORD SALOON

In this brochure we proudly present new Honda Accord Saloon – the latest in a line of truly superb vehicles that have set new standards of luxury, design, performance, style and finish.

Even a quick glance at the smooth, flowing lines will tell you that this Accord Saloon is truly new, and yet, it still retains that distinctive tradition of excellence that has become a mark of the Honda automobile, a tradition that identifies the basic function of the modern car but then refines it to the point where each model takes on its own distinctive personality.

Perhaps the most significant example of this refinement process will only be revealed when you drive Accord Saloon because now, it's powered by a totally new 1.8 litre, 12 valve, cross-flow engine that offers more performance potential than ever before.

Coupled to a five-speed manual gearbox or the optional, new four-speed fully automatic with a special lock-up torque-converter.

As Honda owners have come to know well, owning an Accord Saloon can be an experience of discovery as much as an experience in driving pleasure.

As has often been said, the car offers very few options because most features are built-in as integral parts of the car from the very beginning.

Features like central locking, electric windows, speed-responsive power-steering and tinted window glass are but few of the many, many exciting, innovative and useful features you'll discover and use with pleasure in your Accord Saloon.

New 4AT Automatic Transmission

It's fully automatic and it's four-speed – fourth being an overdrive ratio – and it's one of the lightest and most compact systems available – A triumph for Honda engineering design.

The new system also features a lock-up torque converter system which eliminates

slippage in the torque converter when the vehicle is operating in fourth ratio at highway cruising speeds.

This increases the efficiency of the transmission and improves fuel economy.

Power Steering

Honda's advanced system again ensures that you get the best of both worlds – maximum assistance at low and parking speeds, decreasing gradually to the point where, on the highway, assistance is minimal and road feel is maximised.

Airconditioning

The most desirable option available for your Accord Saloon will almost certainly be Honda's fully integrated, all-year-round airconditioning system which allows you to control the temperature inside the cabin to your exact needs in all seasons.





Optional headlight protectors fitted to this model.

ACCORD HATCHBACK

Presenting Honda Accord Hatchback—a new model that is more than ever before the right car for today.

Honda Accord Hatchback's fast, free-flowing lines promise high-spirited performance and dashing excitement and the promise is more than fulfilled on the road but equally, Honda's traditions of total design excellence mean that Honda Accord is far more than a sporty hatchback.

It's a young family car or, at the touch of a button, a load carrying station wagon—Honda Accord Hatchback is an interstate tourer or a suburban commuter—its versatility allows it to be virtually anything you want it to be.

Now, Accord Hatchback is more powerful than ever before with a totally new 1.8 litre, 12 valve, cross-flow engine with immense potential for performance. Nevertheless, it's still one of the most economical under 2 litre vehicles available.

As would be expected, Honda Accord Hatchback is packed with features and innovations that continue the traditions of excellence and the standards of quality and finish that were set at the very beginning.

Power Steering

Speed-responsive, power-assisted steering makes parking and low speed manoeuvring almost fingertip easy but the system is designed in such a way that assistance decreases in proportion to road speed so that, at highway speeds, you get the driving benefit of good road feel. You stay in touch with the car and the surface it's on.

New 4AT Automatic Transmission

It's fully automatic and it's four-speed—fourth being an overdrive ratio—and it's one of the lightest and most compact systems available—A triumph for Honda engineering design.

The new system also features a lock-up torque-converter system which eliminates

slippage in the torque converter when the vehicle is operating in fourth ratio at highway cruising speeds.

This increases the efficiency of the transmission and improves fuel economy.

Airconditioning

Apart from the transmission option, you will want to consider airconditioning that lets you control the weather in the cabin. Push-button simple and fully integrated, Honda Accord Hatchback's airconditioning makes driving a comfortable pleasure in almost any conditions.





Optional Honda alloy wheels fitted to this model.

HONDA CIVIC WAGON

Versatile, changeable, adaptable, variable—there are not enough words to describe the way you can set up your Honda Civic Wagon.

It's a five-seater passenger vehicle with a huge luggage space, it's a two-seater with what looks like a football field of space behind, it's both those things and half of each, it's even a double bed sleeper if you like...

The Honda Civic Wagon is versatility beyond words and yet, it's also a Honda first, last and foremost because it provides the same standards of excellence that are the hallmark of every Honda vehicle.

The 12-valve, cross-flow engine is a masterpiece of performance and fuel-efficiency matched ideally to a five-speed manual gearbox or Honda's unique, optional Hondamatic transmission which includes an overdrive ratio with a torque converter lock-up to provide fuel efficiency comparable to that of a manual in fifth gear on the highway.

Throughout the Civic Wagon there are thoughtful and genuinely useable pockets and storage compartments which add another dimension to the meaning of the word utility.

The suspension incorporates anti-dive front and anti-lift rear technology for added handling and braking stability.

The versatility of the interior is repeated in individual seats with even the rear, split, passenger seat backs having three settings.

In terms of options and add-on extras, you are severely limited in Civic Wagon because virtually everything comes as standard. Apart from the Hondamatic transmission, you really only have to decide whether you want the added comfort of integrated airconditioning to complete what is one of the most remarkably versatile vehicles on the road today... A vehicle that could only be a Honda!

Honda... the Art of Automotive Excellence.





HONDA CIVIC SEDAN

To describe Honda Civic 4-door Sedan as a small luxury car is to damn it with faint praise indeed.

Rarely if ever before has a car which, by its external dimensions ranks as a small vehicle, offered so much in the way of internal comfort and style.

As Honda owners have come to know and expect, this 1985 model is indeed a refined version of its predecessor but those changes have been made for a purpose and are an admirable demonstration of Honda's philosophy of constant and meaningful improvement to the breed.

Inside the car, you'll find items such as a tilt-adjustable steering column, comprehensive instrumentation, cloth seats, handy pockets and coin trays and the like, all designed with your comfort in mind.

The inside is more than matched by the smooth, aerodynamically efficient and stylish outside.

Add to that the performance and efficiency of a 1.5 litre, 12-valve, cross-flow engine matched to the standard 5-speed gearbox and you have a vehicle with just about everything you could want built-in and that's why with Honda Civic Sedan you have virtually no options – the only "add-on" decisions you'll be called upon to make are whether you would like the extra comfort of fully integrated airconditioning and the convenience of Hondamatic transmission.

The most difficult problem you'll face is probably that of finding where to buy your Civic Sedan because, as with most new Honda cars, they can be hard to find at times.

That's because owning and driving a Honda is something very, very special.

Honda... The art of Automotive Excellence.





CIVIC GL HATCHBACK

As those who have come to know and enjoy the rare pleasure of owning and driving Honda Civic would expect, Honda Civic Hatchback GL for 1985 is not a totally new, all-different, all-extra story at all – rather, in keeping with Honda's design philosophy, it's a natural progression from what went before with small but significant changes and refinements to an already near-ideal motoring experience.

For 1985, there is dual remote control external rear-view mirrors and the upholstery is all cloth.

Perhaps more important is the fact that Civic Hatchback is still undeniably a Honda through and through with a standard of performance, fuel efficiency, handling and comfort unequalled by cars in any class.

The 12-valve, cross-flow engine is a power-house of smooth, flexible performance ideally suited to city or highway driving and it drives through a sporty 5-speed manual gearbox or optional Hondamatic transmission which features a unique, torque-converter lock-up system which operates on the overdrive ratio at highway cruising speeds to provide fuel economy comparable with a manual in fifth.

Honda Civic Hatchback occupies a unique and special place in the hearts of those that own and drive one – take a test drive and find out why.

Honda... the Art of Automotive Excellence.

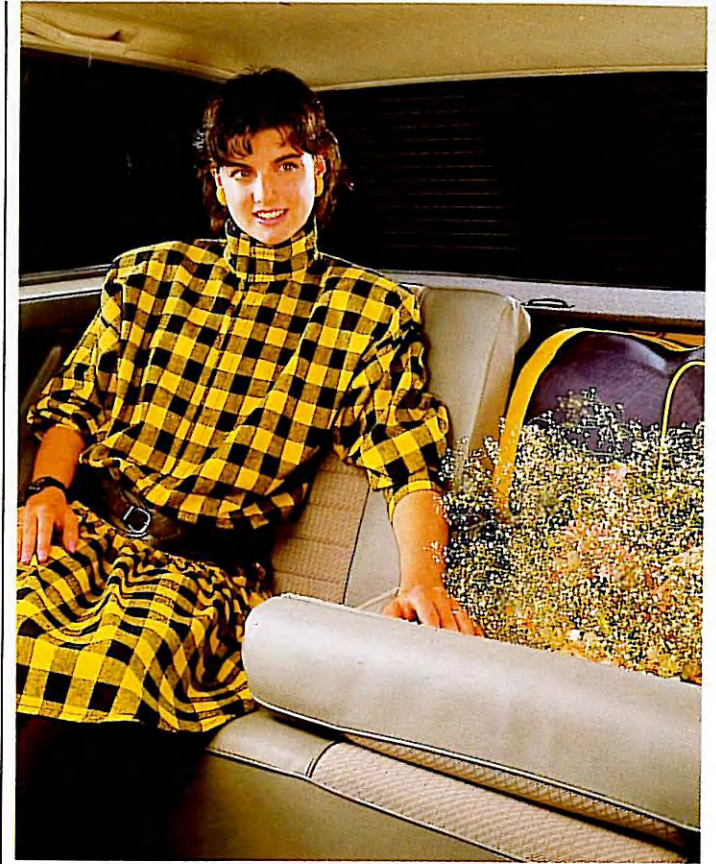



HONDA CIVIC HATCHBACK

Honda Civic Hatchback's smooth, sporting style promises road-going performance and handling that will set it above the competition and when you get behind the wheel and settle in to drive it, that promise is admirably fulfilled.

The 12-valve, cross-flow engine is a powerhouse of smooth, flexible performance ideally suited to city or highway driving and yet, as you'd expect with a Honda, the performance potential does not compromise remarkable fuel efficiency in any way.

As those who own Civic know, the Hatchback is a beautifully balanced and matched combination of performance, handling, comfort, style and economy, put together in a way that makes owning and driving Civic Hatchback a rare and pleasurable experience.

To find out what makes Honda Civic Hatchback so special, take a test drive as soon as you can.

Honda... the Art of Automotive Excellence.





Optional Honda alloy wheels and headlight protectors fitted to this model.

HONDA CITY

In these days when technological achievements and breakthroughs occur almost daily in one field or another, the word unique is over-used and often misapplied, but if ever a vehicle deserved the title, it's new Honda City. Honda City is truly unique – unlike anything you've ever seen, anything you've ever driven before.

Its very shape proves the point at first glance and that shape is worth discussing in some detail because it represents Honda's very latest aerodynamic developments in practical, working form.

Room To Spare

The shape of City gives a clue to the fact that inside there are enormous amounts of usable room for passengers and luggage thanks to the increased roof height and the brilliant use of space.

Additionally, there are a number of storage pockets and compartments built into the vehicle's interior to ensure that small items are stored securely and safely.

Instrumentation and major driving controls are all ideally placed to ensure maximum driver comfort and safety.

Performance To Spare And More

City's 1231 cc, 4 cylinder, OHC engine, producing around 41 kW and coupled to a five speed, all synchromesh gear-box, offers a level of performance and power that must be experienced to be fully appreciated. Acceleration is, to put it simply, quite startling for a vehicle of City's size and is due, in no small part, to the extensive use of weight reduction techniques.

The resultant high power to weight ratio produces excellent economy in all driving conditions, too.

Suspension To Match The Performance

Fully independent suspension all around gives City the sort of handling agility that would put many so-called sports cars to shame and

when it's combined with rack and pinion steering and steel belted radial ply tyres, you're looking at a combination that's as good as Honda's renowned technological skills can make it.

New for '85 – Hondamatic

The optional Hondamatic transmission features a petrol saving overdrive ratio that gives you the added economy of a manual gearbox at highway cruising speeds.

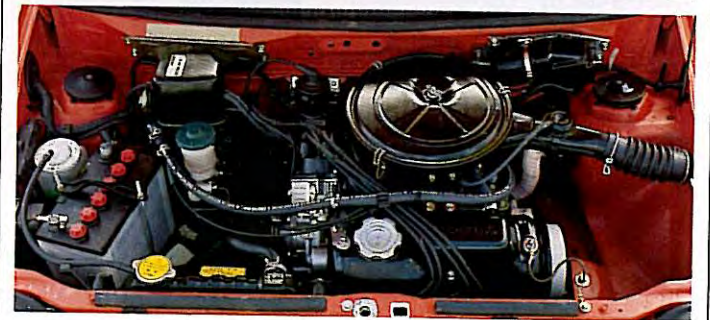

PRELUDE

TECHNICAL SPECIFICATIONS

ENGINE Liquid cooled, OHC, in line four cylinder 4-stroke with 3 valves per cylinder. Transverse mounted, FWD. Twin CV carburetors with auto choke.

DISPLACEMENT 1829 cc

BORE & STROKE 80 x 91 mm

COMPRESSION RATIO 9.1:1

HORSEPOWER

5 speed: 106 ps @ 5,500 rpm (78 kW) DIN
4 speed auto: 102 ps @ 5,500 rpm (74 kW) DIN

TORQUE

5 speed: 15.8 kg-m @ 4,000 rpm (155.1 Nm) DIN
4 speed auto: 15.6 kg-m @ 3,500 rpm (153.1 Nm) DIN

TRANSMISSION 5 speed manual synchromesh or optional 4 speed automatic

STEERING Speed responsive, power assisted rack and pinion with 4-stage steering wheel height adjustment with memory and collapsible column

SUSPENSION 4-wheel independent Front: Double wishbone with coil spring and stabiliser
Rear: MacPherson strut with coil spring and stabiliser

BRAKES 4-wheel discs with Honda anti-lock braking system. Front ventilated. Handbrake fully automatic adjustment

TYRES Michelin 185/70HR13 MXV steel-belted radial ply

WHEELS Cast machined aluminium alloy
L x W x H 4295 x 1690 x 1295 mm

WHEELBASE 2450 mm

TRACK Front - 1470 mm
Rear - 1470 mm

GROUND CLEARANCE 153 mm

FUEL TANK CAPACITY 60 litres

CURB WEIGHT Manual - 995 kg
Auto - 1005 kg

TURNING CIRCLE 11.2 metres at body

MAJOR FEATURES

▲ Retractable quartz-halogen headlamps.
▲ Sports-type single "wide-sweep" windscreen wiper. ▲ Integrated front air dam. ▲ Flexible rear spoiler. ▲ Laminated windscreen with band tint. Other glass smoke tinted. ▲ Side protector strips.
▲ Fully integrated year-round air conditioning: ▲ Full-flow heater/demister system with full front window demisting and "feather-touch" controls. ▲ Power operated glass sunroof with automatic wind deflector and sunshade. ▲ Power operated radio antenna. ▲ Power operated windows ▲ AM-FM stereo radio/cassette player. ▲ Rear window wiper/washer/demister systems.
▲ Remote controls for fuel-filler flap, boot release and driving mirrors. ▲ Door pockets. ▲ Fully reclining, rally-style front bucket seats. ▲ Full-width, fold-down rear seat. ▲ Velour cloth trim seats. ▲ Locking, illuminated glove compartment.
▲ Day/night rear view mirror. ▲ Full instrumentation includes speedometer with odometer and trip meter, tachometer, fuel gauge, temperature gauge, electronic mode indicator (automatic), safety indicator panel plus comprehensive driving and safety function warning light systems. ▲ Column mounted controls for headlamps, parking lights, overtaking flashers, hi-lo beam and front and rear wiper/washer systems.

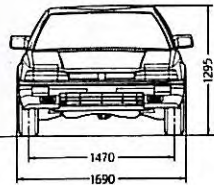
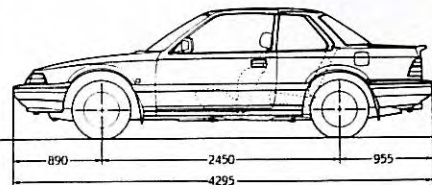
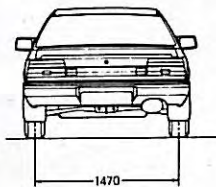

ACCORD SALOON

TECHNICAL SPECIFICATIONS

ENGINE Liquid-cooled, OHC, four-stroke, in-line four cylinder, transverse mounted. Front wheel drive.

DISPLACEMENT 1829 cc

BORE & STROKE 80 x 91 mm

COMPRESSION RATIO 9.1:1

HORSEPOWER 100 ps/5800 rpm

TORQUE 15 kg-m/3500 rpm

TRANSMISSION 5-speed manual synchromesh or optional 4-speed. Auto transmission with lock up.

STEERING Speed-responsive power-assisted rack and pinion with collapsible steering column.

SUSPENSION Four-wheel independent with MacPherson strut.

BRAKES Hydraulic, servo-assisted, ventilated discs front. Hydraulic, servo-assisted drums with PCV rear.

TYRES 185/70SR13 steel belted radial.

L x W x H 4455 x 1665 x 1375 mm

WHEELBASE 2450 mm

TRACK Front - 1445 mm
Rear - 1420 mm

GROUND CLEARANCE 165 mm

FUEL CAPACITY 60 litres

CURB WEIGHT 977 kg (Man.)
992 kg (Auto.)

TURNING RADIUS 5.7 m

MAJOR FEATURES

▲ Speed responsive power assisted rack and pinion steering. ▲ Full flow heater/demister with side window demist.
▲ Unique 'Multi-Flow' ventilation system.
▲ Rear passengers' heater ducts.
▲ Electric rear window defroster.
▲ Combination meters: ▲ Tachometer.
▲ Speedometer/odometer/trip meter.
▲ Water temperature/fuel gauges.
▲ Safety indicator panel. ▲ Service interval indicators. ▲ AM/FM radio/stereo cassette player. ▲ Electrically operated antenna.
▲ Digital quartz clock with date mode.
▲ Lockable, illuminated glove-box.
▲ Fully corded upholstered seats.
▲ Fully reclining front bucket seats.
▲ Rear fold down centre armrest with storage compartment. ▲ Central door locking system. ▲ Magazine pockets.
▲ Remote fuel filler flap opening.
▲ Remote control, lockable boot opener.
▲ Child-proof rear door locks. ▲ Remote control door mirrors. ▲ Fully carpeted throughout, including doors. ▲ Cloth headlining. ▲ Illuminated front ashtray.
▲ Illuminated cigarette lighter.
▲ Headlights 'left on' warning chime.
▲ Power operated windows.
▲ Seat tilt adjustment.

OPTIONS

▲ 4-speed fully automatic transmission with overdrive ratio and lock up. ▲ Year round, fully integrated air-conditioning.

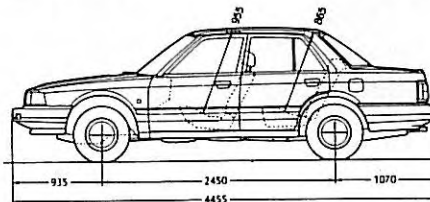
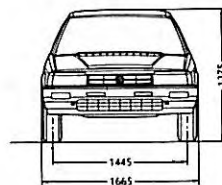

ACCORD HATCHBACK

TECHNICAL SPECIFICATIONS

ENGINE Liquid-cooled, OHC, four-stroke, in-line four cylinder, transverse mounted. Front wheel drive.

DISPLACEMENT 1829 cc

BORE & STROKE 80 x 91 mm

COMPRESSION RATIO 9.1:1

HORSEPOWER 100 ps/5800 rpm

TORQUE 15 kg-m/3500 rpm

TRANSMISSION 5-speed manual synchromesh or optional 4-speed. Auto transmission with lock up.

STEERING Speed-responsive power-assisted rack and pinion with collapsible steering column.

SUSPENSION Four-wheel independent with MacPherson strut.

BRAKES Hydraulic, servo-assisted, ventilated discs front. Hydraulic, servo-assisted drums with PCV rear.

TYRES 165/70 SR 13 steel belted radial.

L x W x H 4455 x 1665 x 1375 mm

WHEELBASE 2450 mm

TRACK Front - 1445 mm
Rear - 1420 mm

GROUND CLEARANCE 165 mm

FUEL CAPACITY 60 litres

CURB WEIGHT 977 kg (Man.)
992 kg (Auto.)

TURNING RADIUS 5.7 m

MAJOR FEATURES

▲ Speed responsive power assisted rack and pinion steering. ▲ Full flow heater/demister with side window demist.
▲ Unique 'Multi-Flow' ventilation system.
▲ Electric rear window defroster.
▲ Combination meters: ▲ Tachometer.
▲ Speedometer/odometer/trip meter.
▲ Water temperature/fuel gauges.
▲ Safety indicator panel. ▲ Service interval indicators. ▲ AM/FM radio/stereo cassette player. ▲ Digital quartz clock with date mode. ▲ Lockable, illuminated glove-box.
▲ Full tricotee upholstered seats.
▲ Fully reclining front bucket seats.
▲ Split rear seatback. ▲ Rear side pockets.
▲ Remote control door mirrors. ▲ Fully carpeted throughout. ▲ Remote tailgate release. ▲ Rear window washer/wiper.
▲ Illuminated front ashtray. ▲ Illuminated cigarette lighter. ▲ Headlights 'left on' warning chime. ▲ Removable folding rear shelf. ▲ Carpeted cargo deck with concealed jack and handle storage.
▲ 2 speed wiper/washer system with intermittent position.

OPTIONS

▲ 4-speed fully automatic transmission with overdrive ratio and lock up. ▲ Year round, fully integrated air-conditioning.

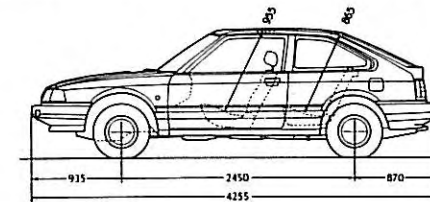
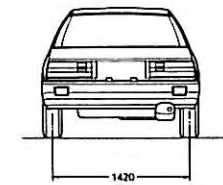
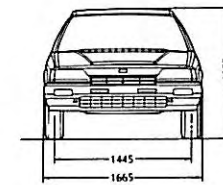

CIVIC WAGON

TECHNICAL SPECIFICATIONS

ENGINE Liquid-cooled, OHC, four-stroke in-line four-cylinder, transverse mounted. Front wheel drive.
DISPLACEMENT 1488 cc
BORE & STROKE 74 x 86.5mm
COMPRESSION RATIO 8.7:1
HORSEPOWER 85 ps @ 6,000rpm
TORQUE 12.8kg-m @ 3,500rpm
TRANSMISSION 5-speed manual or 3-speed Hondamatic with lock-up.
STEERING Rack and pinion
SUSPENSION Front - Independent strut with torsion bar. Rear - trailing link beam type.
BRAKES Front - Power assisted disc. Rear - Drum.
TYRES 175/70 SR-13 steel belted radials.
L x W x H 3990 x 1625 x 1490mm
WHEELBASE 2450mm
TRACK Front - 1400mm Rear - 1415mm
GROUND CLEARANCE 165mm
FUEL CAPACITY 46 litres
CURB WEIGHT 905kg (Manual) 920kg (Hondamatic)

MAJOR FEATURES

▲ Instrumentation: Speedometer, tachometer, odometer, trip meter, fuel gauge, water temperature gauge, warning lights for high beam, alternator, hazard lights, oil pressure, choke, brake fluid, parking brake. ▲ Full flow ventilation with side window demisting. ▲ Electric wiper/washer systems front and rear. ▲ Electric rear window demisting. ▲ Direct control driver and passenger door mirrors. ▲ AM/FM radio. ▲ Full cloth upholstery. ▲ Fully reclining front seats with head restraint. ▲ Eight-way adjustable rear seat with head cushions. ▲ Hatchback release from driver's seat. ▲ Cigarette lighter. ▲ Sunvisors. ▲ Coin tray. ▲ Quartz halogen headlamps. ▲ Laminated windscreen. ▲ Steel belted radial ply tyres. ▲ Child-proof rear door locks. ▲ "Headlight on" reminder.

OPTIONS

▲ Hondamatic transmission with lock-up.
▲ Year-round, fully integrated air-conditioning.

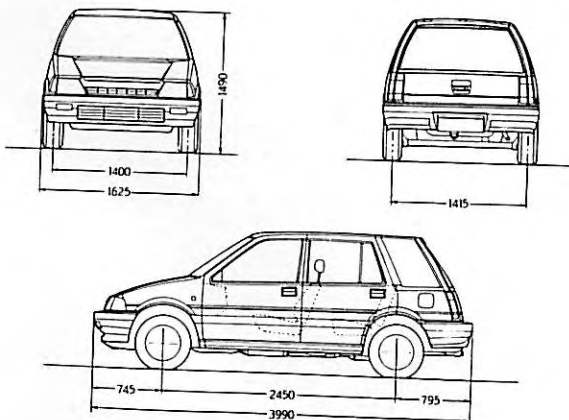

CIVIC SEDAN

TECHNICAL SPECIFICATIONS

ENGINE Liquid-cooled, OHC, four-stroke, in-line four-cylinder, transverse mounted. Front wheel drive.
DISPLACEMENT 1488 cc
BORE & STROKE 74 x 86.5mm
COMPRESSION RATIO 8.7:1
HORSEPOWER 85 ps @ 6,000rpm
TORQUE 12.8kg-m @ 3,500rpm
TRANSMISSION 5-speed manual or 3-speed Hondamatic with lock-up.
STEERING Rack and pinion with steering column height adjustment.
SUSPENSION Front - independent with torsion bar and strut. Rear - trailing arm beam axle with Panhard rod and coil springs.
BRAKES Hydraulic, servo-assisted, discs front. Hydraulic, servo-assisted, drums, rear.
TYRES 165/70 SR-13 steel belted radials.
L x W x H 4145 x 1630 x 1385mm
WHEELBASE 2450mm
TRACK Front - 1400mm Rear - 1415mm
GROUND CLEARANCE 165mm
FUEL CAPACITY 46 litres
CURB WEIGHT 865kg (Manual) 880kg (Hondamatic)
TURNING RADIUS 5.0 m

MAJOR FEATURES

▲ Instrumentation: Speedometer, tachometer, odometer, trip meter, fuel gauge, water temperature gauge, warning lights for high beam, alternator, hazard lights, oil pressure, choke, brake fluid, parking brake. ▲ Full flow ventilation with side window demisting. ▲ Electric wiper/washer systems on front. ▲ Electric rear window demisting. ▲ Direct control driver and passenger door mirrors. ▲ AM/FM radio. ▲ Full cloth upholstery. ▲ Fully reclining front seats with head restraint. ▲ Trunk lid opener. ▲ Cigarette lighter. ▲ Sunvisors. ▲ Coin tray. ▲ Quartz halogen headlamps. ▲ Laminated windscreen. ▲ Steel belted radial ply tyres. ▲ Child-proof rear door locks. ▲ Tilt adjustable steering. ▲ "Headlight on" reminder.

OPTIONS

▲ Hondamatic transmission with lock-up.
▲ Year-round, fully integrated air-conditioning.

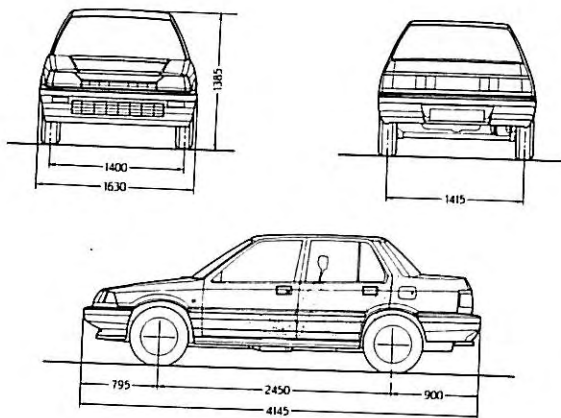

CIVIC GL HATCHBACK

TECHNICAL SPECIFICATIONS

ENGINE Liquid-cooled, OHC, four-stroke in-line four-cylinder, transverse mounted. Front wheel drive.
DISPLACEMENT 1488 cc
BORE & STROKE 74 x 86.5mm
COMPRESSION RATIO 8.7:1
HORSEPOWER 85 ps @ 6,000rpm
TORQUE 12.8kg-m @ 3,500rpm
TRANSMISSION 5-speed manual or 3-speed Hondamatic with lock-up.
STEERING Rack and pinion with steering column height adjustment.
SUSPENSION Front - independent with torsion bar and strut. Rear - trailing arm beam axle with Panhard rod and coil springs.
BRAKES Hydraulic, power-assisted, discs front. Hydraulic, power-assisted, drums, rear.
TYRES 165/70 SR-13 steel belted radials.
L x W x H 3810 x 1635 x 1340mm
WHEELBASE 2380mm
TRACK Front - 1400mm Rear - 1415mm
GROUND CLEARANCE 165mm
FUEL CAPACITY 46 litres
CURB WEIGHT 825kg (Manual) 840kg (Hondamatic)
TURNING RADIUS 4.9 m

MAJOR FEATURES

▲ Instrumentation: Speedometer, tachometer, odometer, trip meter, fuel gauge, water temperature gauge, warning lights for high beam, alternator, hazard lights, oil pressure, choke, brake fluid, parking brake. ▲ Full flow ventilation with side window demisting. ▲ Electric wiper/washer systems on front and rear. ▲ Electric rear window demisting. ▲ Direct control driver and passenger door mirrors. ▲ AM/FM radio. ▲ Full cloth upholstery. ▲ Fully reclining front seats with head restraint. ▲ Split folding rear seat. ▲ Hatchback release from driver's seat. ▲ Cigarette lighter. ▲ Sunvisors. ▲ Coin tray. ▲ Quartz halogen headlamps. ▲ Laminated windscreen. ▲ Steel belted radial ply tyres. ▲ Rear parcel shelf. ▲ Tilt adjustable steering. ▲ "Headlight on" reminder.

OPTIONS

▲ Hondamatic transmission with lock-up.
▲ Year-round, fully integrated air-conditioning.

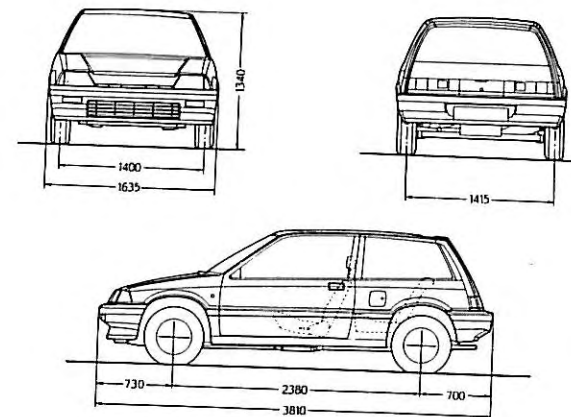

CIVIC HATCHBACK

TECHNICAL SPECIFICATIONS

ENGINE Liquid-cooled, OHC, four-stroke in-line four-cylinder, transverse mounted. Front wheel drive.

DISPLACEMENT 1488 cc

BORE & STROKE 74 x 86.5mm

COMPRESSION RATIO 8.7:1

HORSEPOWER 85 ps @ 6,000rpm

TORQUE 12.8kg-m @ 3,500rpm

TRANSMISSION 5-speed manual.

STEERING Rack and pinion

SUSPENSION Front – independent with torsion bar and strut. Rear – trailing arm beam axle with Panhard rod and coil springs.

BRAKES Hydraulic, power-assisted, discs front. Hydraulic, power-assisted, drums, rear.

TYRES 165/70 SR-13 steel belted radials.

L x W x H 3810 x 1625 x 1340mm

WHEELBASE 2380mm

TRACK Front – 1400mm
Rear – 1415mm

GROUND CLEARANCE 165mm

FUEL CAPACITY 45 litres

CURB WEIGHT 825kg (Manual)

TURNING RADIUS 4.9m

MAJOR FEATURES

▲ Instrumentation: Speedometer, odometer, trip meter, fuel gauge, water temperature gauge, warning lights for high beam, alternator, hazard lights, oil pressure, choke, brake fluid, parking brake. ▲ Full flow ventilation with side window demisting. ▲ Electric wiper/washer systems on front. ▲ Electric rear window demisting. ▲ Direct control driver door mirror. ▲ Semi cloth upholstery. ▲ Fully reclining front seats with head restraint. ▲ Split folding rear seat. ▲ Cigarette lighter. ▲ Sunvisors. ▲ Coin tray. ▲ Quartz halogen headlamps. ▲ Laminated windscreen. ▲ Steel belted radial ply tyres. ▲ "Headlight on" reminder.

OPTION

▲ Year-round, fully integrated air-conditioning.

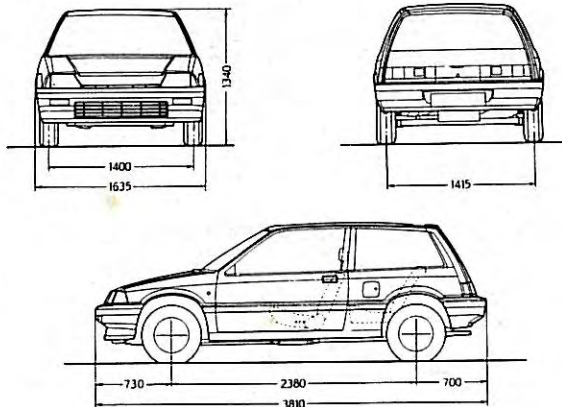

HONDA CITY

TECHNICAL SPECIFICATIONS

ENGINE Liquid-cooled OHC in line four. Transverse mounted FWD.

DISPLACEMENT 1231cc

BORE x STROKE 66 x 90 (mm)

COMPRESSION RATIO 10.2:1

HORSEPOWER 41 kW/5000 rpm

TORQUE 9.3 kg-m at 3500 rpm

TRANSMISSION 5-speed manual all synchromesh or optional 3-speed Hondamatic transmission.

STEERING Rack and pinion

SUSPENSION Front – McPherson strut. Rear – Strut with separately mounted coil spring.

BRAKES Front – Power assisted disc brakes. Rear – Drum.

TYRES 145 SR 12 steel belted radial.

L x W x H 3380 x 1570 x 1470mm

WHEELBASE 2220mm

TRACK Front – 1370mm
Rear – 1370mm

GROUND CLEARANCE 160mm

FUEL CAPACITY 41 litres

CURB WEIGHT 685kg

TURNING RADIUS 4.9m (at body)

MAJOR FEATURES

▲ Halogen headlights. ▲ Power assisted front disc brakes. ▲ Steel belted radial tyres. ▲ Remote control external rear view mirrors. ▲ 4 outlet heater/ventilator system. ▲ Front and side window demister with 3-speed fan. ▲ Fuel gauge. ▲ Temp. gauge. ▲ Warning lights for oil pressure, battery/charge, brake condition, parking brake, high beam. ▲ Dash illumination control. ▲ Cigarette lighter. ▲ Tricot covered, fully upholstered seats. ▲ Full carpeting throughout. ▲ Load restraining barrier. ▲ E.L.R seat belts. ▲ Concealed jack and handle stowage. ▲ Concealed rear wheel stowage. ▲ Soft padded sun visor. ▲ Full height rear opening door. ▲ Rear wiper/washer. ▲ Heated rear window.

Printed in Australia GNA H812 50m 3/85

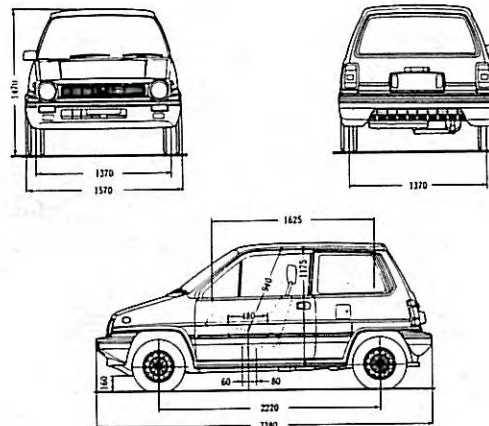

COLOURS

Select your Honda from the range of colours available. Due to shipping and freight uncertainties, some colour and model availabilities may vary time to time. Check with your Dealer for current information.

In the interests of product improvement, Honda Motor Co. Ltd. reserves the right to change the specifications contained herein at any time without prior notice.

ACCESSORIES & OPTIONS

There is a large range of factory-approved options available for your Honda. They provide you with extra comfort, convenience and safety.

 **HONDA**