

**H HONDA**

*Progress with Distinction.*



SEDAN & HATCHBACK  
**CIVIC**



# HATCHBACK



H/B. \$18500

Air 1250

4 door \$19500



There's a lot to admire about Honda Civic Hatchback GLI!

For a start, the smooth, elegant, European styling says a lot about your own personal style and taste... That you appreciate and understand the finer things... That given the choice between quality and show, you'll opt for quality every time! But there's a great deal more to Civic Hatchback than just stylish good looks...

---

**MODERN STYLE PLUS MORE**

---

It's a vehicle for people of the eighties who are looking for quality, value, comfort, style, performance, economy, durability and everything else that goes into making the modern motor car what it should be but, sadly, what it so often is not. Civic Hatchback is a vehicle for those who are not prepared to waste time and money adding-on features and options from a catalogue because Civic Hatchback is remarkably complete when it leaves the factory.



# HATCHBACK

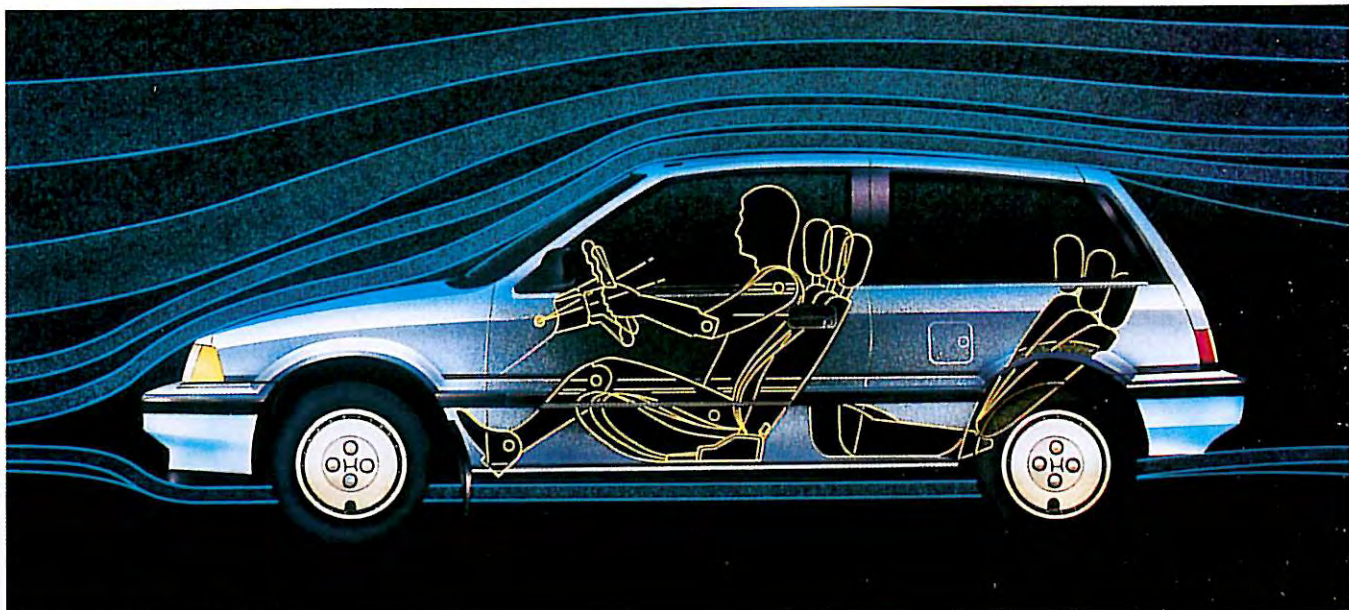

*Hatchback's low coefficient of drag of 0.34*



*Air conditioning optional at extra cost*



Spacious interior



Large rear wiper



Accurate quartz digital clock



Pioneer AM/FM stereo radio-cassette

## THE "EXTRAS" AREN'T EXTRA

The extras aren't extra at all! A quality sound system (AM/FM/Cassette player), electric wiper-washer systems at both front and rear, direct control external driving mirrors, tilt-adjustable steering column which when combined with a new and very adjustable driver's seat means that it's possible to set a superbly comfortable driving position... these features and many more, are just a part of the Civic Hatchback story of excellence.

## AND THE LIST GOES ON

There's a "headlights on" reminder chime, a digital clock, a split, fold-down rear seat, a neat coin tray for parking or emergency money and the hatchback can be opened from your driving position.

Perhaps, above everything else that impresses about Civic, is the amount of room for driver and passengers. Honda has always been noted for the intelligent use of interior space, but in Civic Hatchback, Honda has excelled even its own high standards.

## A JOY TO DRIVE

On the road, Civic Hatchback, with its superb handling, performance and economy matches or exceeds everything in its class for safety and comfort. Steady, smooth and sure on the highway for long-distance touring, it's equally at home in suburban traffic where its size, sparkling performance and extraordinary manoeuvrability make it ideal.

The optional automatic transmission - now 4-speed - has the unique, Honda torque converter "lock-up" which provides economy similar to that of manual transmission.

## A PLEASURE TO OWN

All-in-all, Honda Civic Hatchback is a fine car which combines the best of style, elegance and grace with remarkably efficient performance and economy. Above all, Honda's legendary attention to detail has produced an unusually rewarding car to own... An unusually pleasurable car to drive.



# SEDAN





Four-door convenience and usefulness with four-cylinder performance and economy... that's the basics of Honda Civic Sedan but, Honda Civic Sedan is anything but basic. It's unquestionably one of the best-appointed and most luxuriously comfortable, four-door sedans ever built... anywhere!

The level of luxury is astounding and is equalled only by the remarkable amount of room in what is, by its outside dimensions, a small, very manoeuvrable vehicle.

---

**LUXURY THAT'S BUILT IN**

---

But most important of all, the luxury appointments, the features and benefits are not add-ons, to be selected and paid for after you've decided to buy the car... They're all part of the rich and rewarding pleasure of owning and driving Honda Civic Sedan.



# SEDAN



Automatic with "Torque Converter" lock-up

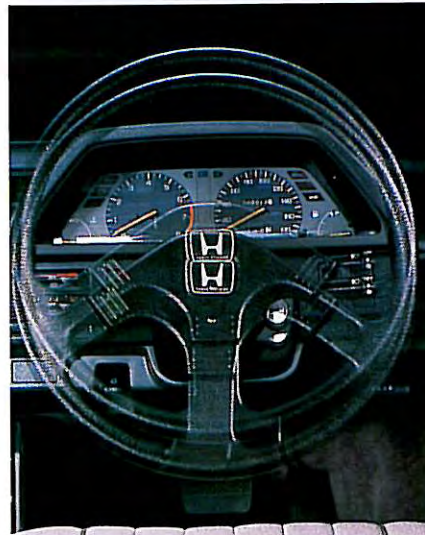

Adjustable steering wheel



Large comfortable interior.



Large interior controlled mirrors



Functional rear styling



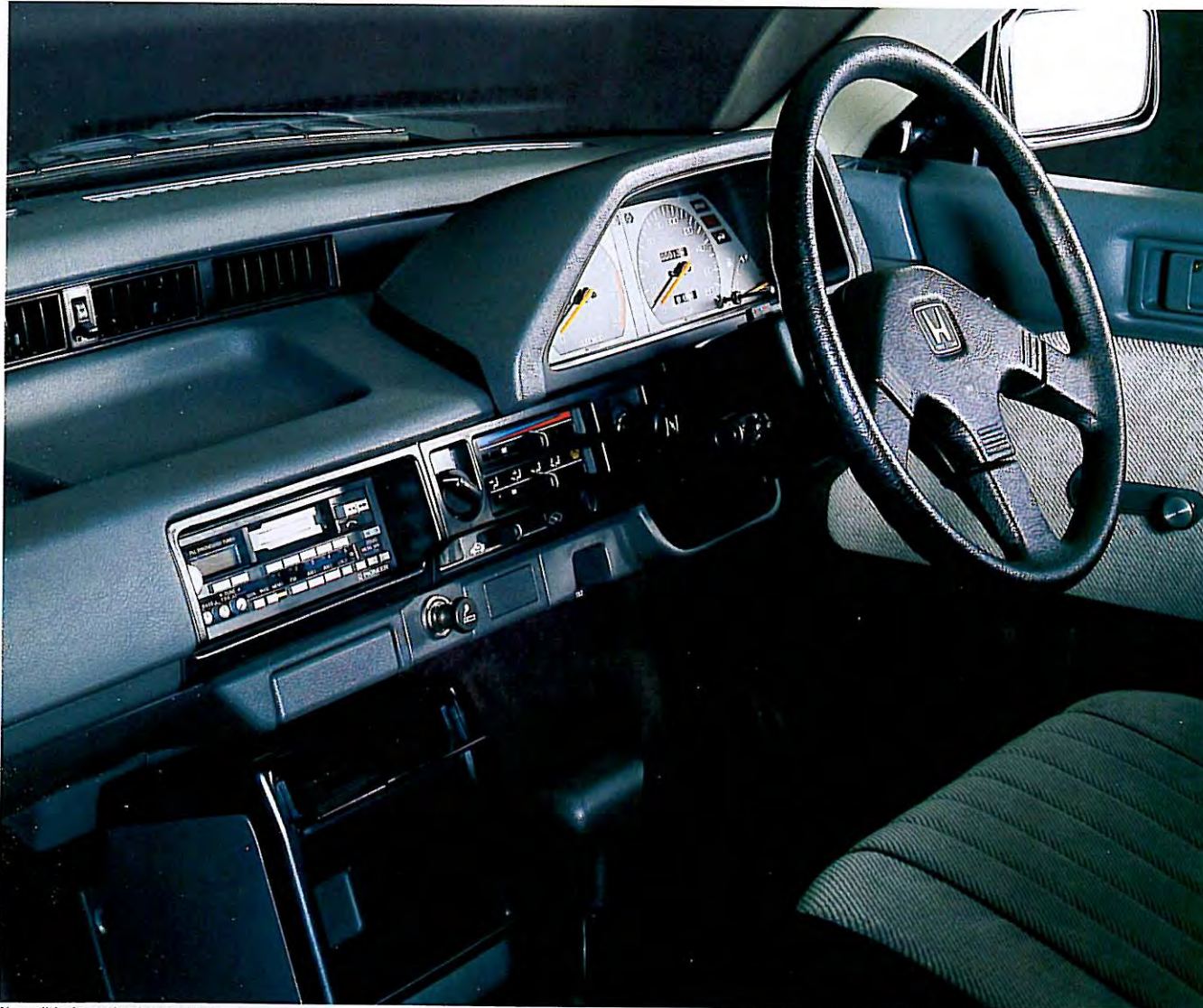

## A HOST OF FEATURES

Consider merely a few of these features: a top quality sound system (AM/FM/Cassette player), direct control driving mirrors on both doors, remote opening for the cavernous boot from your driving seat, full instrumentation including tachometer, full-flow ventilation and heating including side-window demisting, electric rear-window demisting, laminated windshield, childproof rear door locks, tilt-adjustable power steering, steel-belted radial ply tyres and many other thoughtful and genuinely useful features to make every trip in Honda Civic Sedan a genuine driving pleasure.

## A JOY TO DRIVE

And make no mistake, driving is exactly what Honda Civic Sedan is all about... On the highway or around town, Civic's comfort, handling and sparkling performance is a unique motoring experience.

Air conditioning optional at extra cost



Adjustable steering wheel



Pioneer AM/FM stereo radio-cassette

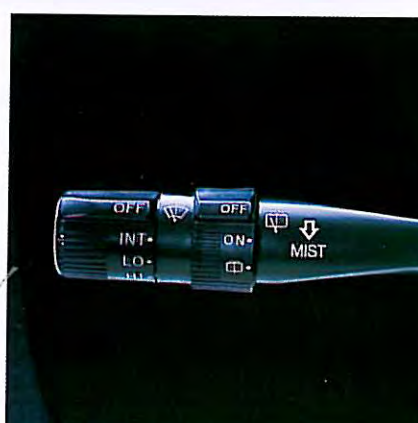

Stalk controls



## ENGINE

At the heart of every Honda Civic is the renowned, all-aluminium 4-cylinder, 12-valve, OHC, cross-flow engine, driving through the front wheels.

A product of many years of dedicated development technology, this 1.5-litre power plant produces remarkable power with quiet, economical efficiency. The 12-valve system, two intake and one exhaust per cylinder, offers the driver levels of flexibility and power that were simply inconceivable a few short years ago.

On the highway, the engine will cruise effortlessly and quietly at the legal limit all day and yet, in heavy suburban traffic, it has the kind of responsive power underfoot that's needed to stay in the clear and out of danger.

It's powerful, responsive and flexible but it's also supremely economical and efficient, so that driving pleasure can be enjoyed to the full. Naturally, and as you'd expect from a company which has been in the forefront of emission control technology for well over a decade, your Honda Civic runs exclusively on unleaded fuel!

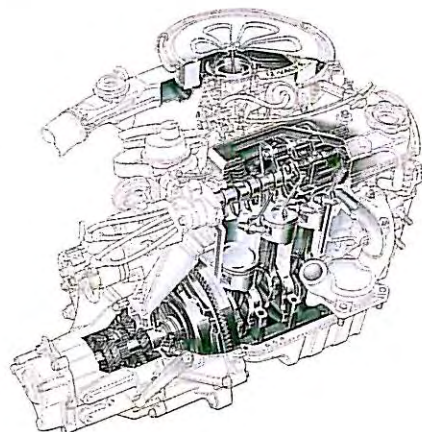

## SUSPENSION

As you'd expect from Honda, Civic suspension is a product of Honda's unswerving determination to design and produce the best possible system and then improve and refine it to even greater standards of effectiveness. It provides an ideal balance of comfort and smoothness with the sort of precision and accuracy that ensures the car behaves admirably even under difficult conditions. At the front, independent torsion-bar struts with a stabiliser feature anti-dive geometry for maximum effective control under braking. At the rear, a trailing-link beam incorporates a stabiliser and anti-lift geometry for additional safety and handling.

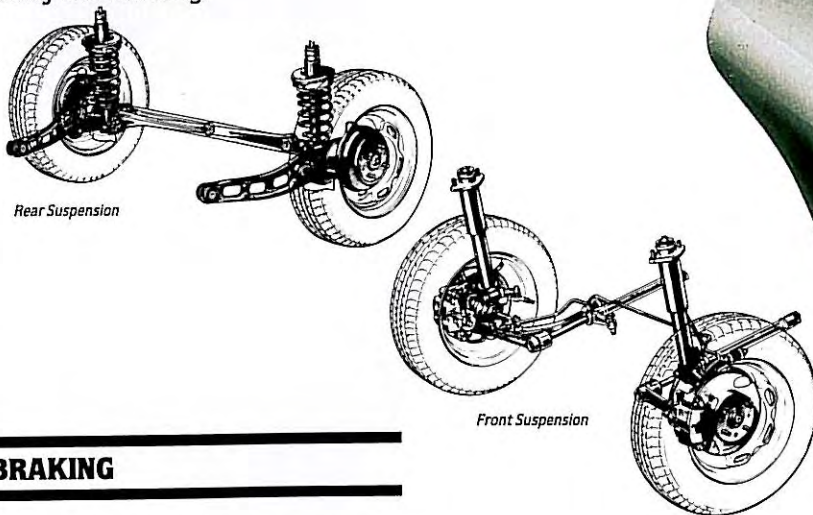

## BRAKING

Braking control and efficiency are ensured by large, servo-assisted front discs and leading/trailing shoe rear drums. The circuit is divided diagonally into two, for an extra margin of safety.

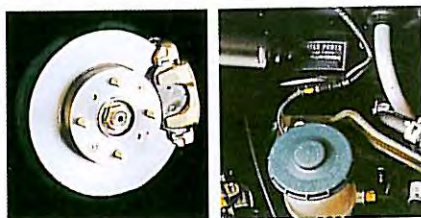

## TRANSMISSION

Standard on all Honda Civic models is a superbly smooth, 5-speed manual gearbox with brilliantly matched ratios to make driving in any conditions easy and rewarding.

As an option, you can select the exciting, four-speed Hondamatic transmission. This unique, Honda-developed system provides the driver with all the benefits and ease of fully-automatic gear-shifting.

## TORQUE CONVERTOR LOCK-UP

At highway speeds in fourth ratio, a special device locks the torque converter, effectively eliminating any slippage, providing economy similar to that of manual transmission.

## HONDAMATIC With Lockup Torque Converter

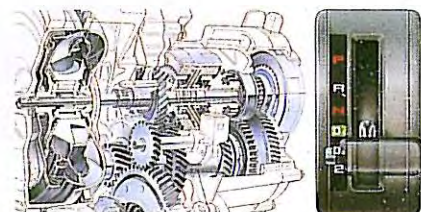

Automatic with "Torque Converter" lock-up

## CIVIC HATCHBACK GL

Overall length	3845mm
Overall width	1625mm
Overall height	1340mm
Wheelbase	2380mm
Track - Front	1400mm
Track - Rear	1415mm
Ground clearance	165mm
Transmission	5-speed manual or 4-speed Hondamatic with lock-up on 4th gear
Curb weight - Manual	860kg
Curb weight - Hondamatic	880kg
Fuel tank	45 litres
Engine type	Liquid cooled, OHC, four-stroke in-line four-cylinder, transverse mounted. Front wheel drive
Bore & Stroke	74x86.5mm
Displacement	1488cc
Compression ratio	8.7:1
Horsepower	85ps @ 6,000rpm
Torque	12.8 kg-m @ 3,500rpm
Steering	Rack & pinion with steering column height adjustment
Suspension - Front	Independent with torsion bar and strut
Suspension - Rear	Trailing arm beam axle with Panhard rod and coil springs
Tyres	165/70SR - 13 steel belted radials
Brakes - Front	Hydraulic servo-assisted discs
Brakes - Rear	Hydraulic servo-assisted drums

## MAJOR FEATURES

- ▲ Instrumentation: Speedometer, tachometer, odometer, trip meter, fuel gauge, water temperature gauge, warning lights for high beam, alternator, hazard lights, oil pressure, brake fluid, parking brake
- ▲ Full flow ventilation with side window demisting
- ▲ Electric wiper/washer systems on front and rear with intermittent and mist function
- ▲ Electric rear window demisting
- ▲ Direct control driver and passenger door mirrors
- ▲ AM/FM stereo radio-cassette player
- ▲ Full cloth upholstery
- ▲ Fully reclining front seats with head restraint
- ▲ Split folding rear seat
- ▲ Hatchback release from driver's seat
- ▲ Remote fuel filler release
- ▲ Cigarette lighter
- ▲ Sunvisors ▲ Coin tray
- ▲ Quartz halogen headlamps
- ▲ Laminated windscreen
- ▲ Steel belted radial ply tyres
- ▲ Rear parcel shelf
- ▲ Tilt adjustable steering
- ▲ "Headlight on" reminder

### MAJOR OPTIONS

- ▲ Fully automatic Hondamatic transmission with lock-up
- ▲ Year-round, fully integrated air-conditioning
- ▲ Aluminium alloy wheels

## CIVIC 4 DOOR SEDAN

Overall length	4145mm
Overall width	1625mm
Overall height	1385mm
Wheelbase	2450mm
Track - Front	1400mm
Track - Rear	1415mm
Ground clearance	165mm
Transmission	5-speed manual or 4-speed Hondamatic with lock-up on 4th gear
Curb weight - Manual	905kg
Curb weight - Hondamatic	925kg
Fuel tank	46 litres
Engine type	Liquid cooled, OHC, four-stroke in-line four-cylinder, transverse mounted. Front wheel drive
Bore & Stroke	74x86.5mm
Displacement	1488cc
Compression ratio	8.7:1
Horsepower	85ps @ 6,000rpm
Torque	12.8 kg-m @ 3,500rpm
Steering	Power assisted rack & pinion with steering column height adjustment
Suspension - Front	Independent with torsion bar and strut
Suspension - Rear	Trailing arm beam axle with Panhard rod and coil springs
Tyres	165/70SR - 13 steel belted radials
Brakes - Front	Hydraulic servo-assisted discs
Brakes - Rear	Hydraulic servo-assisted drums

## MAJOR FEATURES

- ▲ Instrumentation: Speedometer, tachometer, odometer, trip meter, fuel gauge, water temperature gauge, warning lights for high beam, alternator, hazard lights, oil pressure, brake fluid, parking brake
- ▲ Power steering
- ▲ Full flow ventilation with side window demisting
- ▲ Electric wiper/washer systems on front and rear with intermittent and mist function
- ▲ Electric rear window demisting
- ▲ Direct control driver and passenger door mirrors
- ▲ AM/FM stereo radio-cassette player
- ▲ Full cloth upholstery
- ▲ Fold down rear seat
- ▲ Fully reclining front seats with head restraint
- ▲ Boot lid opener
- ▲ Remote fuel filler release
- ▲ Cigarette lighter
- ▲ Sunvisors ▲ Coin tray
- ▲ Quartz halogen headlamps
- ▲ Laminated windscreen
- ▲ Steel belted radial ply tyres
- ▲ Child-proof rear door locks
- ▲ Tilt adjustable steering
- ▲ "Headlight on" reminder

### MAJOR OPTIONS

- ▲ Fully automatic Hondamatic transmission with lock-up
- ▲ Year-round, fully integrated air-conditioning
- ▲ Aluminium alloy wheels

## GENERAL VIEW

Unit: mm

### HATCHBACK GL

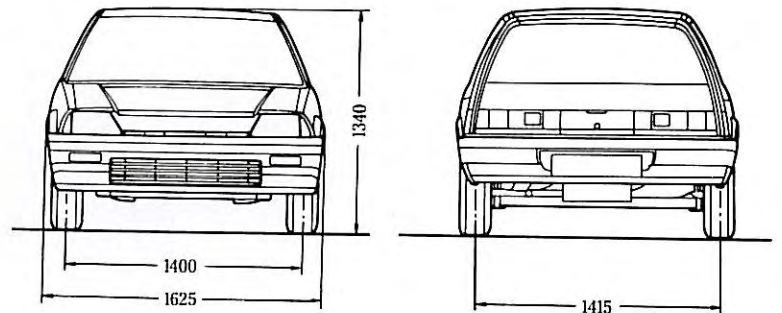
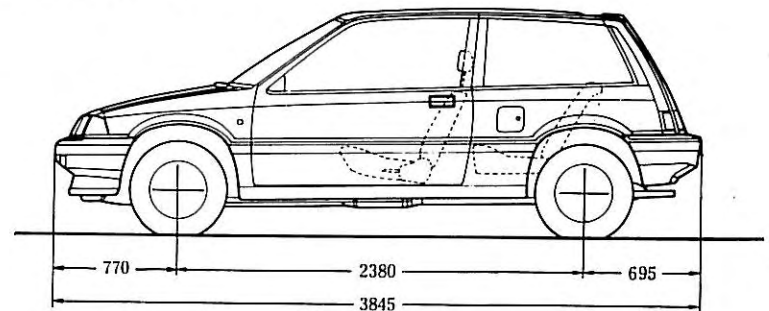

### 4 DOOR SEDAN

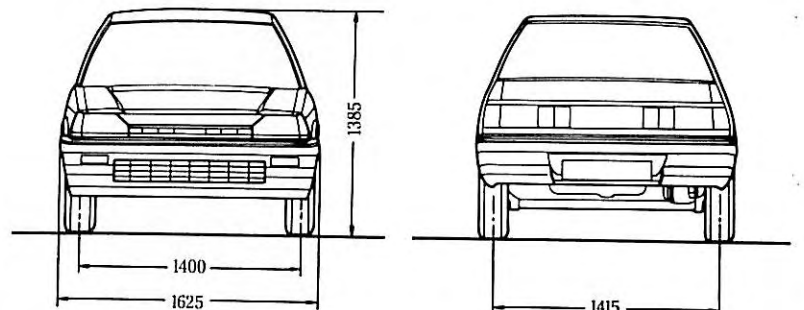
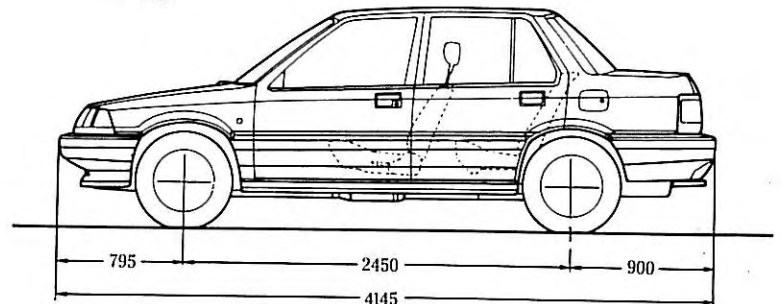

NOTE Due to shipping and freight uncertainties, some colour and model availabilities may vary from time to time. Check with your dealer for current information.

Honda Motor Co. Ltd. reserves the right to change or modify major features or specifications at any time without prior notice. Details, colors, descriptions and illustrations are for information purposes only. As specifications may vary in some states, please check with your Authorised Honda Automobile dealer.



**HONDA**