

HONDA HR-V



Introduction



Any car can get you from A to B.

But where's the fun in that?

For all you know, there could be an awesome adventure just waiting for you at C. Then there's that sensational piece of twisty blacktop on the way to S. And you know the snow's always brilliant at Q. And why don't you ever find an excuse to get up to Z any more?

It's with all these other letters in mind that Honda invented this unique four-wheel drive sports car: the HR-V. They'll tell you that stands for High Rider Vehicle. But what it really stands for is fun. You get a smile on your face just walking up to it. A smile that is guaranteed to grow bigger as you compare the HR-V's on road



performance against some sports coupes. Honda HR-V is the only sports coupe with the advantage of Honda's unique REALTIME 4WD, which operates only when you need more grip.

And, unlike any sports coupe you've ever seen, it has room for more than two collapsible toothbrushes. But we're only warming up.

HR-V is the first four-wheel drive Low Emission Vehicle, with exhaust emissions around 80% cleaner than the Australian standards.* The first four-wheel drive available with Honda's Multimatic CVT (Continuously Variable Transmission) and stepless gearing for super smooth acceleration. The first vehicle under \$50,000 fitted with seatbelt pretensioners and load limiters.

*Australian Design Rule 37/01.

It's the first in its class with anti-pinch electric windows that won't catch a protruding arm. Its got a myriad of storage compartments – you'll probably lose count at 20.

On top of all that, it protects the driver and the passenger with SRS airbags as standard, it surpasses all current and anticipated world safety standards and the frontal structure helps reduce the severity of injury to pedestrians. Not bad for the new kid on the block, hey?

At last someone's put the fun back into function. (Or have they simply put the 'ction' back onto 'fun'?)

Interior



5 door interior shown.



3 door seat colour.



5 door seat colour.



HR-V is active and smart in a way that is a Honda hallmark. It combines the handling of a coupe with great practicality and a distinctive look that sets it apart from anything else.

HR-V allows you to enjoy your lifestyle rather than compromise it. From the stylish exterior, the HR-V has a compact fun aspect. Step inside and you'll notice another surprising side of its character – spacious comfort.

The extra big front seats 'fit' the body. Multi-layered foam padding is contoured to provide ergonomic support and comfort. An overall fresh, youthful approach to the cockpit design makes for a particularly vibrant driving environment.

The sporty two tone dual-meter instrument panel and streamlined dashboard are designed for the driver's needs. Power door locks,

power windows and power adjustable door mirrors are all within easy reach.

The optional air conditioner is CFC-free and efficiently cools the cabin. This is aided by the heat-absorbing windows that reduce harmful UV rays.

Comfort



Door net pocket.

50/50 bifold rear seat (5 door interior shown).



5 door rear seat cup-holder.

When it's cold outside, a triple-dial heater control allows you to turn up the temperature to a toasty warmth.

Inside, the amount of space available is deceptive. There are around 20 storage compartments. Even the cargo space is very generous. There's room for two golf bags. Fold down the seats and you can conveniently stack two snowboards lengthways or, alternatively, up to three golf bags or even two eskies.

The interior of the HR-V is as flexible as you want it to be, while retaining all the superior comfort and visual appeal you've come to expect from a Honda. HR-V – the perfect partner for those on the move.



Technology

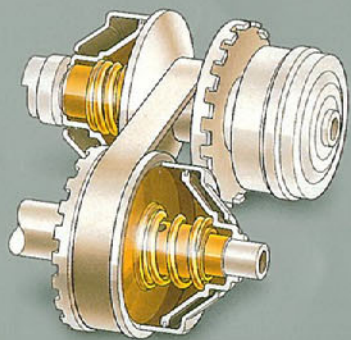

CVT (low transmission ratio).

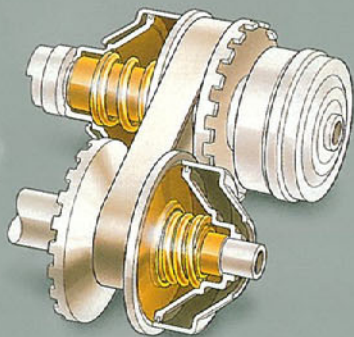

CVT (high transmission ratio).

LEV
LOW EMISSION VEHICLE

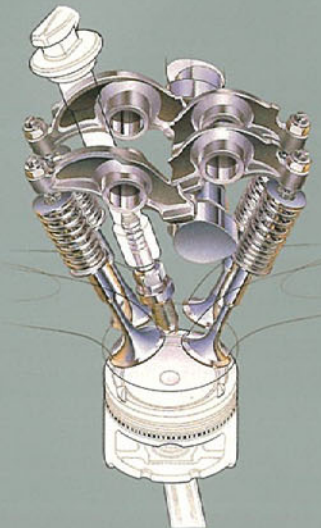

1.6 SOHC 16-valve engine.



HR-V 3 door model shown.

The HR-V is the essence of Honda engineering. To begin with, that means spirited performance. To this end, the HR-V is equipped with an exhilarating and responsive 1.6 litre, SOHC, 16-valve, four cylinder engine. The engine also utilises Honda's LEV (Low Emission Vehicle) technology. It ensures the HR-V produces exhaust emissions that are approximately 80% cleaner than the most stringent Australian standards*. The cleverness doesn't stop there. The HR-V comes with a choice of two transmission systems. Firstly, there's the 5-speed manual, designed to have a sporty feel. Secondly, the optional stepless Multimate CVT (Continuously Variable Transmission). It does away with gears and provides the

*Australian Design Rule 37/01.

'jet-feel' sensation of a smooth, efficient acceleration. An addition to this is Honda's Grade Logic Control that eliminates gear hunting when driving up or down hills.

Then, to handle changing road conditions, there's the Honda Dual Pump REALTIME 4WD system. It's a unique innovation that demonstrates uncanny intelligence when you need it most. The system can dynamically switch between two and four-wheel drive as conditions and traction demand.

For example, if the front wheels lose traction, hydraulic pressure is used to activate a multi-plate clutch transmitting torque to all four wheels simultaneously.

Once in motion, you'll experience HR-V's finely tuned balance of manoeuvrability and handling ease. To achieve this, Honda has

adopted a four-wheel suspension system to create a driving experience that is secure and solid.

That's another unique feature of the Honda HR-V. For a car with so much style, it's also packed with so much substance.

Safety

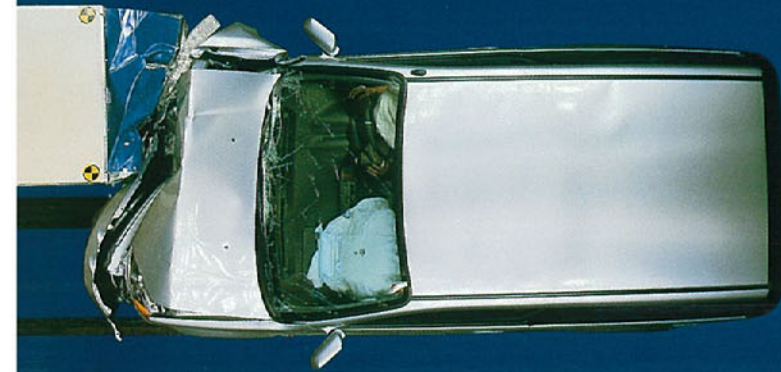

Offset crash test.



Computer designed monocoque body.

Style is not merely about form, it also has to do with function. And one of the most important functions of a car is to protect what is inside as well as what is outside.

The Honda HR-V is equipped with protection that surpasses even the most stringent regulations in the world.

A front crumple zone acts as a protective collision absorbing shield; the central side-pillars are joined in the middle of the floor to efficiently disperse lateral impact; door beams are added for rigidity and safety.

Inside you'll find dual air bags and three-point seat belts with pretensioners on the front belts that'll hug you safely in an emergency.

The Honda HR-V is also designed to protect pedestrians. If the unthinkable should happen, the HR-V structure is designed to help



reduce the chance of pedestrian head injuries. In the engine compartment, space between the engine and bonnet acts to cushion the force of impact.

And then, of course, there's the wider world and environment beyond. This is another area where the Honda HR-V displays its commitment to socially and environmentally responsible technology.

The advanced Low Emissions engine has been designed to help ensure the air you breathe stays clean for now and the future. While the HR-V's miserly fuel consumption preserves the planet's resources, the optional CFC-free air conditioning is kind to the ozone layer. Trichlorethane-free bumpers and a high percentage of components are designed to be recycled.

From the ground up, the Honda HR-V is designed to provide

a new kind of driving experience. It represents a new sense of exhilaration, a new sense of style, a new sense of responsibility.

Ultimately, it introduces a new sense of fun and intelligence that is the Honda HR-V.

Ownership



**The world's finest cars:
the world's finest after sales service.**

At Honda, providing the world's finest after sales service is just as important as building the world's finest cars. The entire Honda Dealer network is dedicated to keeping your new Honda at peak performance, so it gives you years of pleasure. Honda Dealer staff and technicians are factory trained and keep up to date with the most advanced technologies by attending an ongoing series of seminars and training courses. To ensure only the highest standards are maintained, we have strict requirements of a person or entity wishing to open a Honda Dealership.

Every Honda Dealer maintains a comprehensive inventory of Genuine Parts and has access to a central warehouse via the Hondanet computerised order/supply system. Genuine Parts can be delivered quickly anywhere in Australia. Nobody can service and

tune your car like we can. Our cars have such precise engineering that we use specialised, high-tech equipment, unique to Honda.

To maintain the value of your car it should always have regular services. And it always pays to insist on Honda Genuine Parts.

Every new Honda motor vehicle comes with our 3-year, 80,000km warranty. This includes a 3-year surface corrosion warranty and a 6-year rust perforation warranty. We are committed to providing prompt, courteous service in a professional manner at the time of purchase and throughout your ownership.

The Honda Way

"Our Pledge to a Unique Experience"

When you purchase a Honda, we dedicate ourselves to a standard of sales and after sales service that is consistent with the outstanding quality of our products.

Specifications

POWERTRAIN	3 DOOR	5 DOOR
Engine	Inline 4 cylinder SOHC	Inline 4 cylinder SOHC
Capacity	1.6litre – 1590cc	1.6litre – 1590cc
Max power	77kW @ 6200rpm	77kW @ 6200rpm
Max torque	138Nm @ 3400rpm	138Nm @ 3400rpm
Control system	Honda programmed	Honda programmed
	Fuel injection & ignition	Fuel injection & ignition
Emission standard	Low Emission Vehicle LEV	Low Emission Vehicle LEV
Manual transmission	5 speed	5 speed
Automatic transmission	CVT	CVT
	Grade Logic Control	Grade Logic Control
REALTIME 4WD	•	•
Fuel type	Unleaded – ULP	Unleaded – ULP
CHASSIS		
Body type	Monocoque	Monocoque
Front suspension	Macpherson strut	Macpherson strut
Rear suspension	De Dion	De Dion
Stabiliser bars	Front & rear	Front & rear
Power steering	•	•
Wheel type	Steel	Steel
Spare wheel type	Temporary	Temporary
Front brakes	Vented disc	Vented disc
Rear brakes	Drum	Drum
EXTERIOR		
Bumpers	Impact absorbing	Impact absorbing
Front wiper	2 speed & intermittent	2 speed & intermittent
Headlights	Halogen type	Halogen type
Keyless entry	•	•
Power door mirrors	•	•
Roof spoiler	•	•
Rear window demister	•	•
Rear wiper	•	•

Specifications

INTERIOR	3 DOOR	5 DOOR
Ashtray	Relocatable type	Relocatable type
Central locking	●	●
Cup holders	Front x2/Rear x3	Front x2/Rear x2
Dashboard warning lights	Comprehensive array	Comprehensive array
Door pockets	Front x2	Front x2
Driver's window	Auto up/down	Auto up/down
Front passenger seat	Walk through type	—
Glovebox	Dual type	Dual type
Head restraints – front	Adjustable	Adjustable
Head restraints – rear	Adjustable	Adjustable
Immobiliser system	Fully integrated	Fully integrated
Interior illumination	Cargo area	Cargo area
Interior illumination	Courtesy light x2	Courtesy light x2
Interior illumination	Map light	Map light
Lights-on warning	Chime	Chime
Low fuel warning	Light	Light
Power windows	●	●
Seats – front	Fully reclining	Fully reclining
Seats – rear	50/50 split fold down	50/50 split fold down
Seat back pockets	Passenger side	Passenger side
Steering column	Tilt adjustable	Tilt adjustable
Tachometer	●	●
Tripmeter	●	●
Vanity mirror	Driver's sunvisor	Driver's sunvisor
Windows	Heat absorbing	Heat absorbing
ACTIVE SAFETY		
Convex door mirror	Passenger side	Passenger side
Hazard warning lights	●	●
High mounted stop light	●	●
Rear view mirror	Day/night type	Day/night type
Seatbelt reminder	Driver	Driver
Suspension – front	Independent	Independent
Suspension – rear	De Dion type	De Dion type
Transmission shiftlock	Auto only	Auto only

● Standard Equipment — Not Available

Specifications

PASSIVE SAFETY	3 DOOR	5 DOOR
Airbag SRS	Driver & passenger	Driver & passenger
Child safety seat anchorages	x2	x2
Front windscreen	Laminated	Laminated
Fuel tank roll over valve	●	●
Monocoque body construction	●	●
Progressive crumple zones	Front & rear	Front & rear
Screw type fuel cap	●	●
Seatbelt pretensioners	Front seating positions	Front seating positions
Seatbelts – 3 point ELR	All seating positions	All seating positions
Side impact protection	●	●
Steering column	Energy absorbing type	Energy absorbing type
DIMENSIONS		
Length	4005mm	4105mm
Width	1695mm	1695mm
Height	1575mm	1580mm
Ground clearance – laden	175mm	175mm
Weight – tare – man	1152kg	1217kg
– auto	1177kg	1242kg
Turning circle	10.5m	10.8m
Fuel economy – city (litres/100km)	7.8 Man/8.0 Auto	7.8 Man/8.0 Auto
– highway (litres/100km)	6.8 Man/7.0 Auto	6.8 Man/7.0 Auto
Fuel tank capacity	55 litres	55 litres
Wheel size	15 x 5.5JJ	15 x 5.5JJ
Tyre size	195/70 R15 92S	195/70 R15 92S
Towing capacity – trailer with brakes	1200kg Man/800kg Auto	1200kg Man/800kg Auto
– trailer without brakes	500kg	500kg
Seating capacity	4	4
AUDIO		
AM/FM radio, stereo cassette	4 channel x 35 watts	4 channel x 35 watts
CD compatible	CD stacker optional	CD stacker optional
Front speakers	2 x 160mm	2 x 160mm
Rear speakers	2 x 160mm	2 x 160mm
Antenna	Micro type	Micro type



SUPER SONIC BLUE PEARL*



VOGUE SILVER METALLIC*



LIGHTNING SILVER METALLIC*



TAFFETA WHITE



RUBY RED PEARL*



SUNBURST YELLOW METALLIC*



FRESH COPPER METALLIC*

3 DOOR COLOURS

EXTERIOR	INTERIOR
Super Sonic Blue Pearl*	Blue
Vogue Silver Metallic*	Blue
Taffeta White	Blue
Ruby Red Pearl*	Blue
Sunburst Yellow Metallic*	Blue

5 DOOR COLOURS

EXTERIOR	INTERIOR
Super Sonic Blue Pearl*	Dark Blue
Lightning Silver Metallic*	Dark Blue
Taffeta White	Dark Blue
Ruby Red Pearl*	Dark Blue
Fresh Copper Metallic*	Dark Blue

3 DOOR AND 5 DOOR WARRANTY

3 year/80,000kms	●
3 year paint protection	●
6 year corrosion protection	●



Honda Australia Pty. Ltd. A.C.N. 004 759 611.

95 Sharps Road, Tullamarine, Victoria, 3043. Melbourne (03) 9285 5555.

Brisbane (07) 3260 4888. Sydney (02) 8748 3333. Perth (08) 9277 0444.

www.honda.com.au

The fuel consumption figures quoted in this brochure are based on AS2877-1986 test results. You may experience different results depending on driving conditions and the condition of the vehicle. The specifications and major features listed herein are accurate as at the date of printing (February 2000/00YM). However, Honda Australia Pty. Ltd. reserve the right to change or modify specifications and major features at any time without prior notice. Due to ordering, shipping and freight factors, some colour and model availabilities may vary from time to time. Check with your Honda Dealer for current information on availability. Only Genuine Honda Accessories are made to fit Honda vehicles. For a Genuine Honda Accessory brochure contact your Honda Dealer or Honda Australia on 1800 804 954.

APL HRV6066/10M

● Standard Equipment

— Not Available

*Additional Cost

Printed on recycled paper