

MAGNA

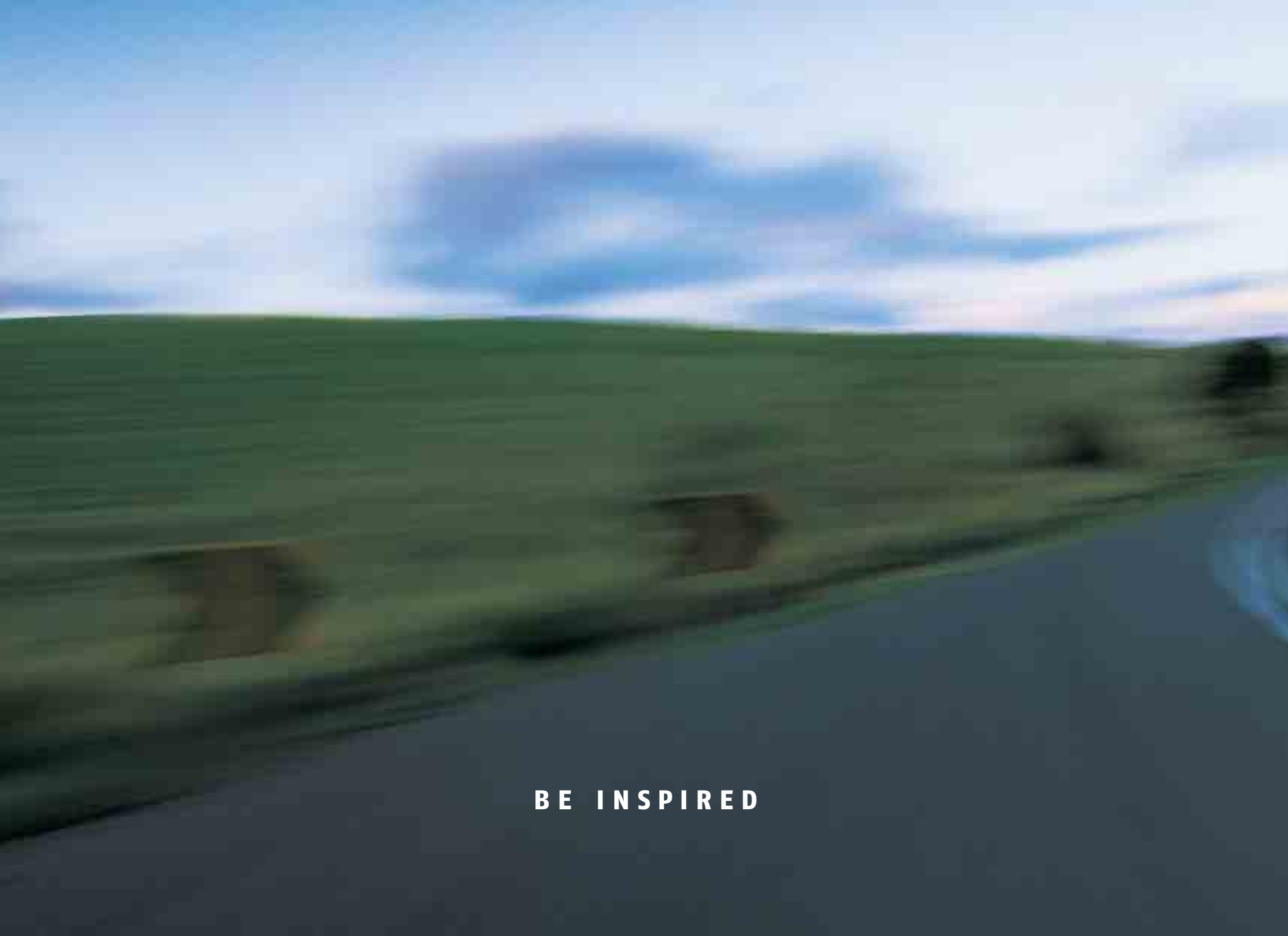



BE INSPIRED



DO ONE THING EVERY DAY THAT INSPIRES YOU

WITH OVER 250 CHANGES ACROSS THE VEHICLE, THE NEW MAGNA HAS BEEN CAREFULLY HONED FROM FRONT TO REAR. WORKING SIDE BY SIDE, MITSUBISHI'S DESIGNERS AND ENGINEERS SET OUT TO CREATE A NEW BENCHMARK IN THE AUSTRALIAN MARKET. THE RESULT IS A RANGE OF IMPROVEMENTS. SOME ARE ALMOST IMPOSSIBLE TO DETECT, WHILE OTHERS ARE INSTANTLY RECOGNISABLE, BUT ALL PLAY A VITAL ROLE IN MAKING THIS MAGNA THE BEST EQUIPPED, LOCALLY BUILT CAR. POWERED BY A 3.5 LITRE SOHC 24 VALVE V6 ENGINE WITH ELECTRONIC MULTI-POINT FUEL INJECTION, THE MAGNA LINE UP OF STANDARD FEATURES IS UNSURPASSED INCLUDING DRIVER, FRONT PASSENGER AND SIDE AIRBAGS, A SIX-WAY ADJUSTABLE POWER DRIVER'S SEAT, CRUISE CONTROL, AUTOMATIC CLIMATE CONTROL AIR CONDITIONING AND FRONT AND REAR POWER WINDOWS.





INSPIRATION IS EVERYWHERE

YOU DON'T HAVE TO LOOK FAR TO FIND INSPIRATION IN THE NEW MAGNA. STAY COOL WITH THE INTUITIVE AUTOMATIC CLIMATE CONTROL AIR CONDITIONING, WHICH IS STANDARD AND FEATURES PRESET TEMPERATURE CONTROL, FIVE SENSORS WHICH DETECT AND MAINTAIN CABIN COMFORT, PLUS REAR AIR CONDITIONING DUCTS FOR FASTER COOLING. YOU WILL ALSO FIND ALL THE SUPPORT YOU NEED IN THE NEWLY DESIGNED DRIVER AND PASSENGER SEATS, WHICH PROVIDE INCREASED LEG ROOM ALL ROUND. THE SPECIALLY CALIBRATED SUSPENSION DELIVERS SPIRITED DRIVING, RESPONSIVE HANDLING, GREATER STABILITY AND, OF COURSE, SUPERIOR RIDE COMFORT.

MAGNA VR-X & VR

POWER AT YOUR FINGERTIPS

The thrill of driving VR-X is enhanced by the tactile, embossed leather, motor sports style steering wheel and leather gear shift with chrome surround. Both VR-X and VR are driven by the 5 speed INVECS II 'Smart Logic' automatic transmission with 'SPORTS MODE' sequential gear shifting, smooth, powerful, convenient and fun.

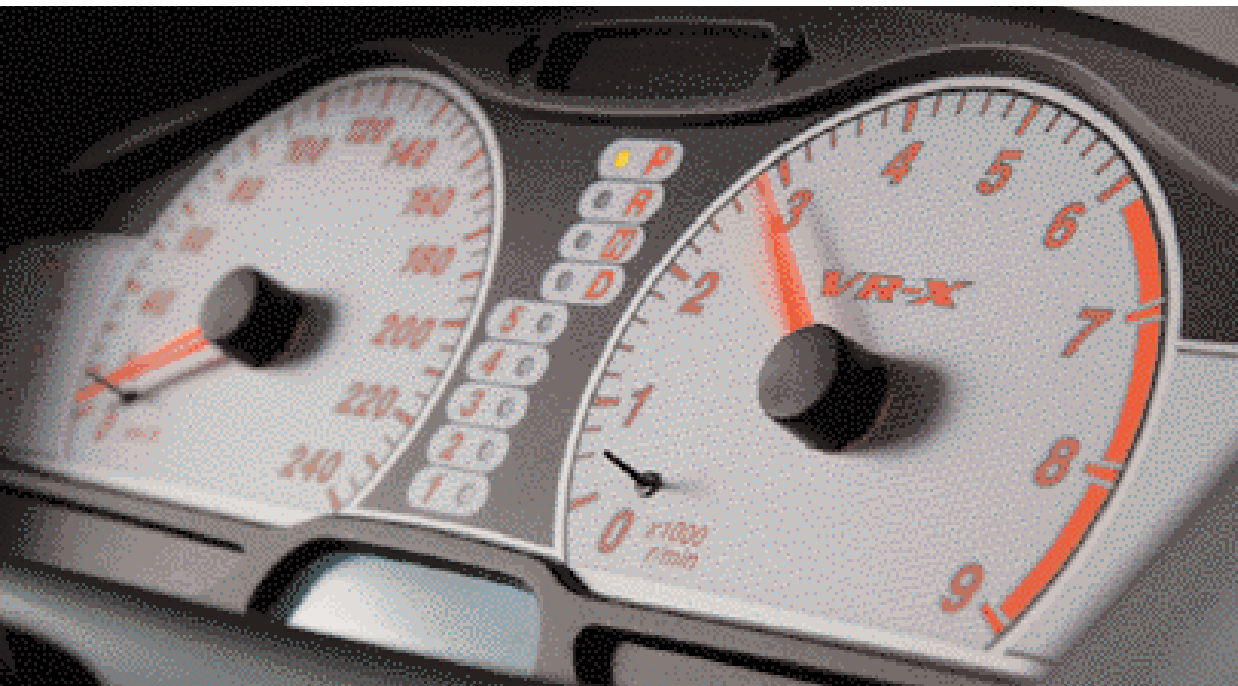

PERFORMANCE TO MATCH

Enhanced with a free flowing Australian designed exhaust system and unique engine calibration, VR-X and VR deliver 163kW of power at 5200rpm and 317Nm of torque at 4500rpm.

SMART ALLOY WHEELS

VR-X has bold five spoke 17" sports alloy wheels and low profile tyres so that the maximum amount of tread stays in contact with the road, delivering optimum handling and grip.



PLAN YOUR TRIP

The VR features graphite coloured highlights to the upper and lower console, plus a sporty leather wrapped steering wheel and gear shift. A 10 function trip computer is standard on all models and includes functions such as: speed alarm, average fuel consumption, distance to empty, distance travelled, service indicator and a rest reminder for those long trips.



BUILT IN SAFETY AND COMFORT

Side airbags are built into the front seats of all models to provide improved side impact protection for both the front passenger and driver. Driver comfort is further enhanced across the range by the six-way power driver's seat with slide, height and tilt adjustments. Sporty leather seats with the embroidered logo are optional in VR-X.



IN CHARGE

Power windows are standard in both the front and rear, with the master controls now centrally positioned for use by either the driver or front passenger.





BE COMFORTABLE

HIGHLIGHTS IN THE VR-X CENTRAL CONSOLE FEATURE A UNIQUE WARM SILVER FINISH WHICH IS COMPLEMENTED BY STRIKING, SPORTS STYLE INSTRUMENTS. GET BEHIND THE WHEEL OF VR-X AND EXPERIENCE THE EASE OF THE 5 SPEED MANUAL TRANSMISSION WHICH DELIVERS SUPER SMOOTH SHIFTING AND MORE TOP END POWER. FOR THOSE WHO LIKE A CHOICE, THERE IS THE GENIUS OF THE INVECS II 'SMART LOGIC' AUTOMATIC TRANSMISSION WITH 'SPORTS MODE' SEQUENTIAL GEAR SHIFTING. THIS TECHNOLOGY TEACHES THE ENGINE TO ANTICIPATE THE STYLE OF THE DRIVER AND THE ROAD CONDITIONS, TO AUTOMATICALLY ADOPT OPTIMUM GEAR CHANGE AND GEAR CHANGE TIMING. THEN, AT THE FLICK OF THE GEAR SHIFT, 'SPORTS MODE' LETS YOU TURN YOUR AUTOMATIC INTO A SPORTY CLUTCHLESS MANUAL FOR HANDS ON, OPEN ROAD DRIVING.

OPTIONAL LEATHER STEERING WHEEL SHOWN



SEE AIR BAG



P
R
M
D
5
4
3
2







BE IN CONTROL

THERE IS NOTHING LIKE FEELING THAT YOU ARE TOTALLY IN CONTROL, ESPECIALLY WHEN YOU COME ACROSS LESS THAN IDEAL DRIVING CONDITIONS. MAGNA'S ADVANCED TRACTION CONTROL* IS TRIGGERED BY SENSORS ON THE WHEELS WHICH WORK TO ACTIVELY MATCH ENGINE POWER TO WHEEL TRACTION. DESIGNED AND CALIBRATED ESPECIALLY FOR AUSTRALIAN ROADS, MITSUBISHI'S TRACTION CONTROL ALSO PROMOTES SMOOTHER, SAFER CORNERING BY MONITORING THE STEERING, ENGINE POWER AND SPEED. THE RESULT IS STABLE ACCELERATION AND CORNERING ON WINDING ROADS, ALLOWING YOU TO SAFELY AND CONFIDENTLY ENJOY MAGNA'S POWERFUL PERFORMANCE.

*NOT AVAILABLE ON AWD AND LPG MONOFUEL MODELS.

MAGNA LS & ES

SMART WORK

LS features the power, smoothness and convenience of Mitsubishi's 4 speed INVECS II 'Smart Logic' automatic transmission with 'SPORTS MODE' sequential gear shifting.

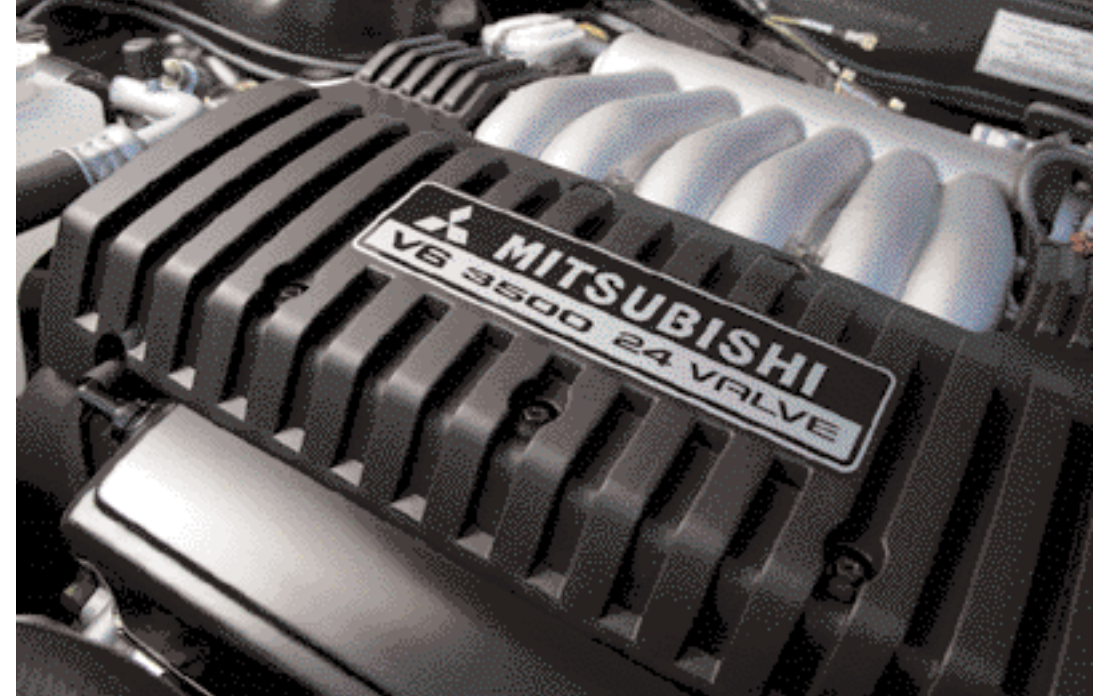

THE POWER AND THE GLORY

Both LS and ES engines have been finely tuned to deliver 155kW of power at 5250rpm and 316Nm of torque at 4000rpm.

A PLACE FOR EVERYTHING

The newly configured Magna interior incorporates a handy console box with a special mobile phone pocket and in built phone accessory socket. The design also perfectly accommodates 6 CDs and a tissue box.





POWER IS FREEDOM

The front and rear power windows on all Magna models are complemented by power mirrors and effortless power steering, for all round convenience.



GREEN MACHINE

The LS and ES models are also available with a purpose built Monofuel LPG system developed specifically for the technologically advanced Magna. So you have a high performance, fuel efficient, cost effective and environmentally friendly engine alternative.



COMFORT AND SAFETY ALL ROUND

The comfort of rear seat passengers is enhanced by rear seat air conditioning ducts, cupholders and extra leg room. Meanwhile, vehicle security is strengthened by standard features such as central locking, remote keyless entry with panic alarm, 2 stage door unlocking, automatic relocking and an engine immobiliser.

THE PERFECT CLIMATE
Ride comfort is even further enhanced in all weather conditions as the climate control air conditioning system maintains the interior temperature selected by the passenger or driver. Automatic sensors constantly monitor conditions inside and outside the car and adjust the fresh or recycled air accordingly.





BE RELAXED

SIT BACK AND LET THE TRIP UNFOLD WITH THE CONVENIENCE OF CRUISE CONTROL, WHICH LETS YOU ENJOY MAGNA'S EFFORTLESS PERFORMANCE ON LONG ROAD TRIPS WITHOUT TOUCHING THE ACCELERATOR. DRIVER COMFORT HAS ALSO BEEN ENHANCED ON ALL MODELS WITH THE INCLUSION OF A SIX-WAY POWER ADJUSTABLE DRIVER'S SEAT DESIGNED TO REDUCE FATIGUE AND INCREASE COMFORT. AND YOU CAN FILL THE CABIN WITH CLEAR, CRISP MUSIC FROM THE AM/FM RADIO AND SINGLE CD, PLUS 6 SPEAKERS IN ES AND 8 SPEAKERS IN LS.



ACC/RES ▲
ON-OFF →
COAST/SET ▼



TCL

MODE

L R

MAGNA AWD & VR AWD



STYLE SLIPS INTO HIGH GEAR

The sporty chrome shift surround is embossed with the AWD logo, while the acclaimed INVECS II 'Smart Logic' 5 speed automatic transmission is coupled with 'SPORTS MODE' sequential gear shifting.



A PRECISION BUILT PERFORMANCE

The Magna AWD range is driven by a powerful, yet fuel efficient, 3.5 litre SOHC 24 valve electronically injected V6 engine which has been designed to complement the QuadTec™ AWD system. The engine's torque and power characteristics have been perfectly matched to the drivetrain to virtually eliminate wheel spin, produce superior road grip and provide enhanced driver enjoyment.

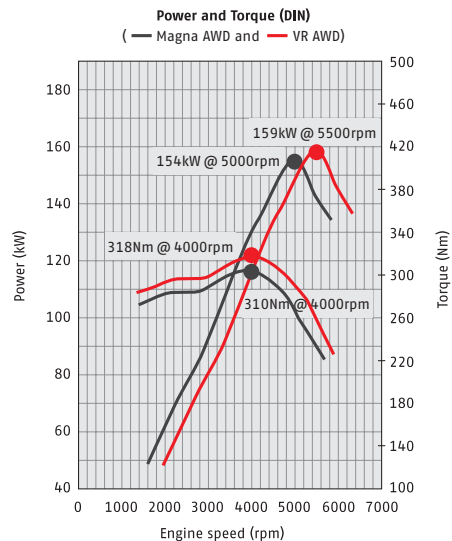

POWER TO PERFORM

Put your foot down and the Magna AWD engine rewards you with maximum power of 154kW at 5000rpm and maximum torque of 310Nm at 4000rpm, while the Magna VR AWD produces an impressive 159kW of power at 5500rpm and maximum torque of 318Nm at 4000rpm. The racy VR AWD also boasts sports suspension, a free flowing exhaust system and low line rear spoiler.



HIGH PERFORMANCE BRAKING

Improved brake stability is a result of the inclusion of high performance brakes featuring responsive 294mm ventilated discs at the front, with two-pot callipers and 284mm ventilated discs at the rear with single-pot callipers. Add Anti-lock Braking System (ABS) with Electronic Brake force Distribution (EBD) and you have a potent package which ensures superior fade free performance.



ALL CLEAR AHEAD

VR AWD features striking sports style instruments, with easy to read dials which minimise driver distraction. The grip of the leather wrapped steering wheel and leather gearshift knob add another dimension of style and driver confidence.



MAKING ITS MARK

The Magna AWD range carries Mitsubishi's new global styling including the distinctive Magna grille, sleek front end and rear tail light combination. The AWD range is distinguished by discreet badging on the front fenders and rear deck lid. Magna AWD features 16" x 6" alloy wheels with 215/60R Bridgestone tyres, while the sporty VR AWD boasts 16" x 7" alloys with Grid II's. Both models also feature unique 10-spoke designs, plus body coloured external mirrors and door handles.



CONFIDENCE IN ALL CONDITIONS

From icy mountain passes to unsealed country roads, the Magna AWD shines in even the most challenging, low traction conditions. Combined with exceptional internal safety features including front and side driver and passenger air bags, front seatbelt pretensioners and a reinforced body structure. Magna AWD offers superior driver confidence in all conditions.

ADVANCED MITSUBISHI QUADTEC™ AWD SYSTEM

THE NEW QUADTEC™ DRIVE TRAIN ENHANCES ACCELERATION, STRAIGHT LINE STABILITY AND MANOEUVRABILITY, WHILE ALSO ENABLING OUTSTANDING PERFORMANCE ON POOR ROAD SURFACES.

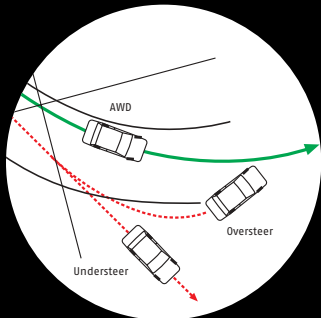
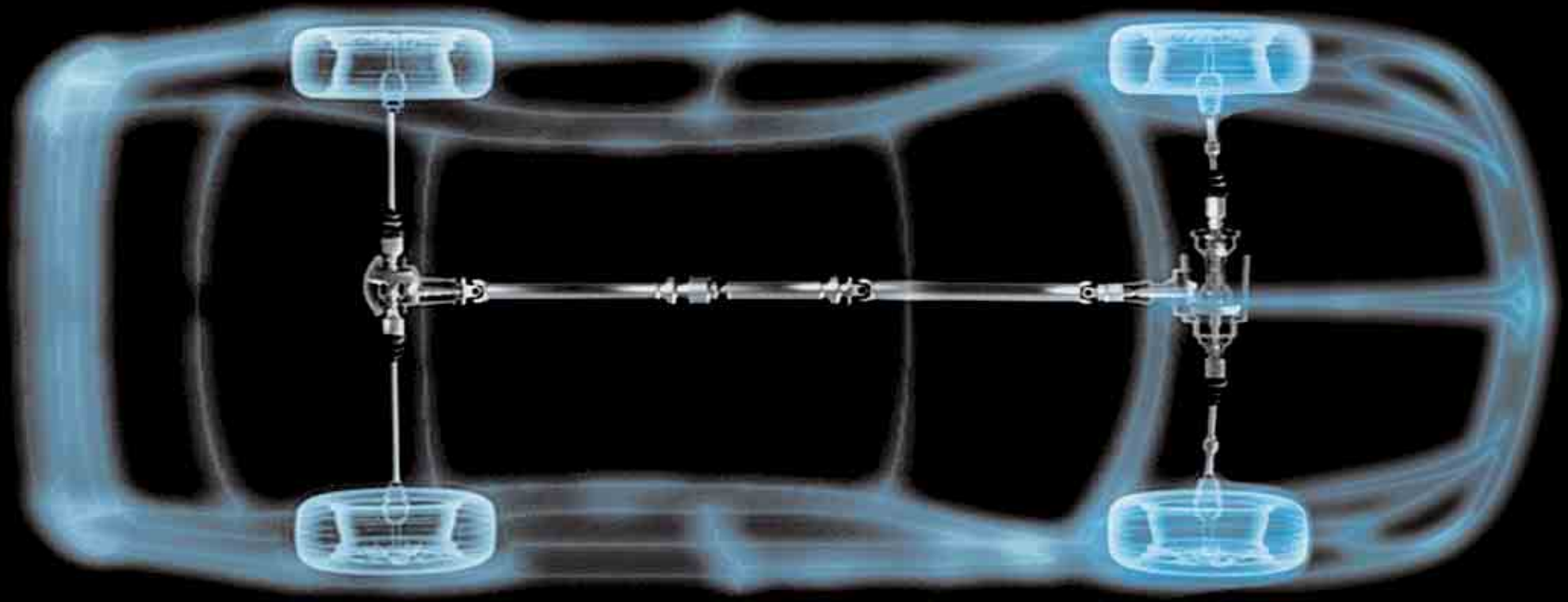

Using many elements from the famed Mitsubishi Lancer Evolution rally bred car, the QuadTec™ AWD system with Limited Slip Differential boasts superior roadholding and outstanding traction, which you can actually feel. This refined AWD system distributes torque evenly to all four wheels, however if it detects slip in any of the wheels the Viscous Coupling Unit automatically and optimally distributes torque to the front and rear wheels to ensure that the car continues to corner efficiently, maintaining stability and power.



Locally built and calibrated for Australian conditions, this intelligent system enhances drive away acceleration, overall stability, grip and cornering control for safer, more spirited driving. And to complement the QuadTec™ AWD system, the Magna AWD and VR AWD have improved high performance brakes, with bigger ventilated front and rear discs and front twin piston callipers.

'SPORTS MODE' SEQUENTIAL GEAR SHIFTING



'SPORTS MODE' makes the INVECS II 'Smart Logic' automatic transmission even more flexible. When the shift lever is moved sideways 'SPORTS MODE' is engaged letting the driver push the lever forward to go up a gear or pull it back to shift down a gear. So you can have the benefits of a normal automatic for around the city, with a more responsive clutchless manual for open road driving.

MAGNA LPG MONOFUEL ENGINE SYSTEM

Magna's 'green' Monofuel LPG system is available on selected, specially built LS and ES models. This system has been specifically designed to match the requirements of Magna's technologically advanced drive train, engine management systems and Mitsubishi's strict emissions standards. The result is a powerful engine that boasts excellent fuel efficiency, while delivering maximum power of 143kW at 5000rpm and maximum torque of 296Nm at 4000rpm. And because safety is always paramount, the LPG tank is positioned forward of the rear axle for protection in the event of a rear impact.

IMPRESSIVE POWER AND TORQUE

All Magna models are powered by a silky smooth 3.5 litre SOHC 24 valve V6 with electronic fuel injection. Magna ES and LS models benefit from 155kW offering enough power for all driving conditions while maintaining excellent fuel economy. The VR and VR-X uses the state of the art engine unit, coupled with a special exhaust system and unique engine calibration to provide even more impressive performance boasting 163kW at 5200rpm.

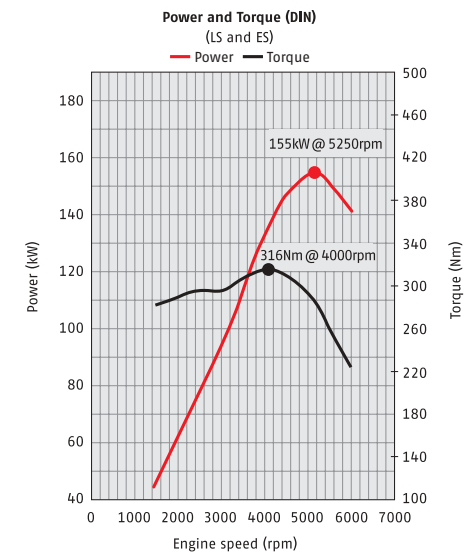
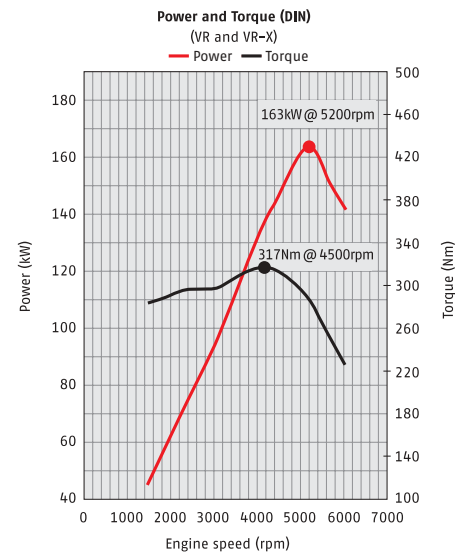

THE SAFEST MAGNA EVER BUILT

SAFETY HAS A FUNDAMENTAL ROLE TO PLAY IN ALL MAGNA MODELS. A SERIES OF NEW FEATURES HAVE BEEN IMPLEMENTED ACROSS THE RANGE FOLLOWING STRINGENT TESTING AND MODIFICATION. ELEMENTS SUCH AS SIDE AIRBAGS, CHILD PROOF REAR DOOR LOCKS AND PRETENSIONERS FOR ADDED SEATBELT SECURITY ENSURE PEACE OF MIND FOR BOTH THE DRIVER AND PASSENGERS.



New multi parabola headlamps deliver improved performance and better illumination in all conditions.



Driver and passenger airbags are complemented by side airbags in the front seats which provide additional occupant protection in the event of a side impact.



Rear passenger safety is further enhanced by lap-sash seatbelts and height adjustable front and integrated rear head restraints.



Driver and passenger fully height adjustable seatbelts are also fitted with pretensioners to secure passengers firmly in their seats in the event of a frontal impact.



Child proof rear door locks and child restraint anchor points, ensure small passengers are taken care of too.

STAY IN CONTROL

The intelligent Traction Control system utilises slip control and trace control technology to make it possible to drive the high performance Magna more confidently and safely, in all conditions. Optional on ES.

The 4 sensor, 4 channel Anti-lock Braking System (ABS) helps the driver maintain steering control, while Electronic Brakeforce Distribution (EBD) delivers braking to both front and rear wheels depending on wheelslip.

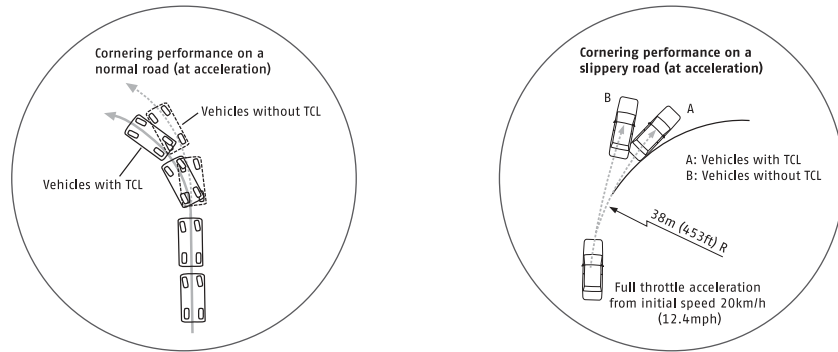

ABS Operation

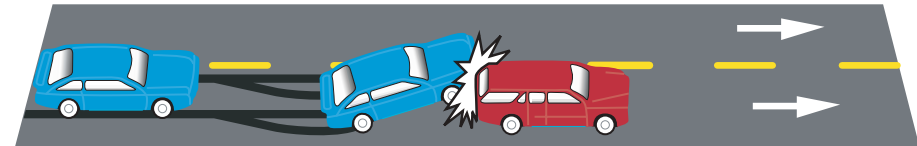

Vehicle without ABS and EBD – all wheels lock causing skidding and steering control is lost.

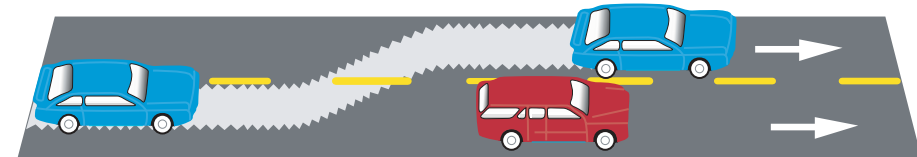

ABS and EBD is fitted to all Verada models – provides greater braking performance and ability to steer around vehicles or obstacles.

BODY OF EVIDENCE

The monocoque Magna body has been upgraded to provide even better frontal and side impact protection. The energy absorbing front section is combined with a stronger, more rigid passenger safety cell featuring thickened high strength steel panels, additional reinforcing panels and structural foams, extra welding and a second side intrusion bar in the front doors.

Upgraded safety means all models now meet the latest Offset Deformable Barrier (ODB) and Dynamic Side Impact requirements.

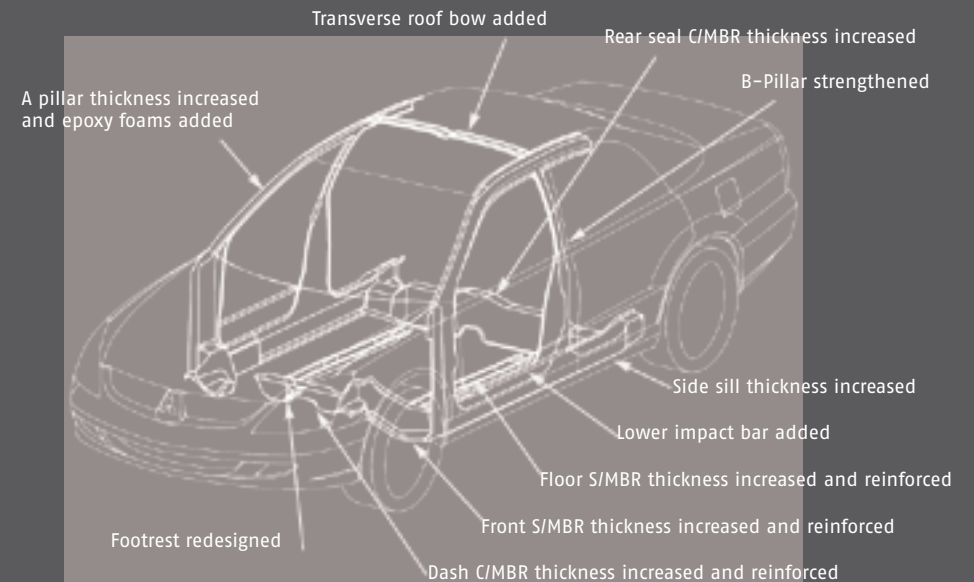

MAGNA VR-X

With its distinctive styling and powerhouse performance, the motorsport inspired VR-X is now better than ever. The full body kit including front air dam, side and rear skirts, rear deck lid spoiler and a large chrome exhaust is accentuated by new fog lamps and VR-X's own eye catching light assembly designed to enhance its different shaped bumper. The result is a smooth and integrated, but aggressive look.

Sports style radiator grille

Multi parabola headlamps

Leather trim option available



Shark eye style front fog lamps

Body coloured bumper bars

Low line rear deck spoiler

Chrome VR-X badging

Body coloured side protection mouldings



Chrome sports exhaust

Dark tint rear combination lamps

17" alloy wheels



AM/FM Radio, 6 disc in-dash CD stacker, 10 speakers.



Sports seats provide improved body support for both safety and comfort.



New, bold five spoke 17" x 7" alloy wheels.



VR-X features a full body kit and shark eye style front fog lamps.

MAGNA VR

Sleek and sporty, VR boasts a host of attention grabbing features including 16" alloy wheels, fog lamps, body coloured mirrors, body coloured side protection mouldings, splash protectors and a new design rear bumper. Inside, the new look and feel includes an improved sports style driver's seat which provides additional body support to enhance safety and all round comfort.

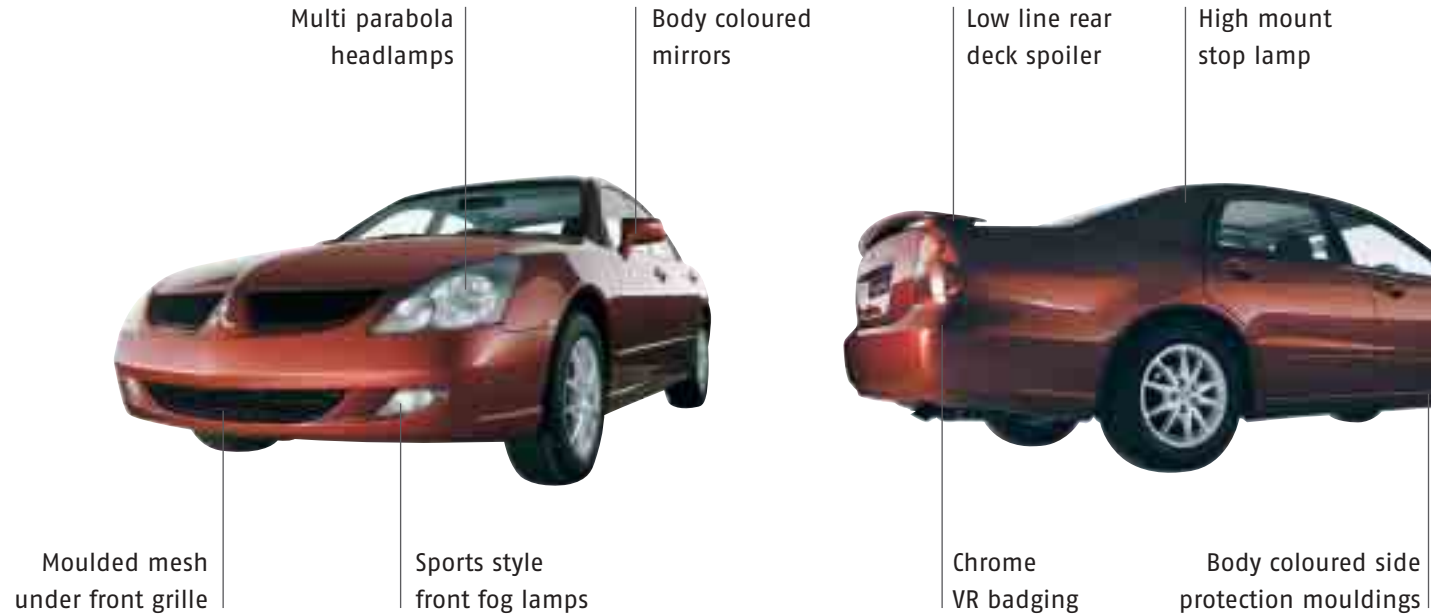

Ten spoke 16" x 7" alloy wheels.



Sophisticated and attractive new woven jacquard seat trim.



Sports style front fog lamps.



Graphite coloured highlights in the console panel.

MAGNA LS

LS offers a level of refinement which is instantly appealing. Inside the cabin you will find contemporary graphite coloured console highlights, new improved seats and a redesigned more user friendly layout including large audio and air conditioning controls. Meanwhile the 4 speed INVECS II 'Smart Logic' automatic transmission with 'SPORTS MODE' sequential gear shifting, is enhanced by the safety and performance benefits of Mitsubishi's Traction Control.



Five spoke 15" x 6" alloy wheels.



Soft and hard wearing two tone knit interior trim.



Multi parabola headlights with dual high beam.



AM/FM radio with in-dash CD and 8 speaker audio unit.

MAGNA ES

The ES is the entry level Magna model offering just about every feature you could ever wish for, as standard. Behind the sophisticated Euro look styling is a car boasting internal improvements in trim, ergonomics and passenger safety, plus fully independent suspension for improved handling. This sophisticated model delivers driver and front passenger side and front airbags, automatic climate control air conditioning, cruise control, front and rear power windows and Magna's legendary performance.

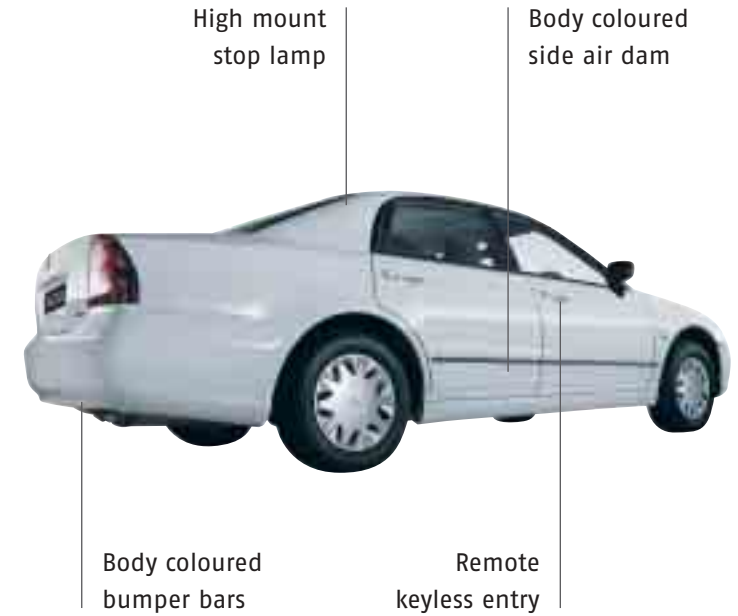

15" x 6" steel wheels with full cover.



Automatic climate control air conditioning.



Stylish two tone interior upholstery.



Side airbags standard across all models.

MAGNA WAGON

When it comes to interior room, safety, comfort and cargo space, Magna Wagon is in a class of its own. Improved seats for the driver and all passengers offer superior comfort, while the automatic climate control air conditioning keeps everyone at an ideal temperature. Stylish, fully integrated roof rails make it easy to add roof racks so you can easily transport all the family's gear and put the dog in the back. Magna Wagon is available in ES, LS and VR variants.



Climate easily controlled with simple three knob arrangement.



One piece fold down rear seat.

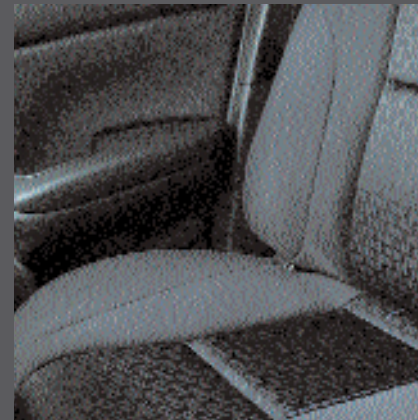

Six-way power adjustable driver's seat, with manual lumbar adjustment.



Body coloured roof spoiler on VR Wagon.

MAGNA SPECIFICATIONS

ENGINE						
3.5 litre V6, SOHC 24 valve with roller rockers and auto lash adjusters						
Bore x stroke	93.0 x 85.8mm					
Capacity	3497cc					
Compression ratio	9.0:1					
Fuel system	Electronically controlled multi-point injection					
PERFORMANCE						
	POWER			TORQUE		
ES and LS	155kW @ 5250rpm			316Nm @ 4000rpm		
VR and VR-X	163kW @ 5200rpm			317Nm @ 4500rpm		
ES and LS LPG	143kW @ 5000rpm			296Nm @ 4000rpm		
AWD	154kW @ 5000rpm			310Nm @ 4000rpm		
VR AWD	159kW @ 5500rpm			318Nm @ 4000rpm		
FUEL TANK CAPACITY						
	71 litres (2WD)		65 litres (AWD)		68 litres (wagon)	
FUEL CONSUMPTION (AS2877) L/100 KM						
	5 SPEED MANUAL		4 SPEED AUTO		5 SPEED AUTO	
	City	Highway	City	Highway	City	Highway
ES	10.5	7.4	11.0	7.0	-	-
LS	-	-	11.0	7.0	-	-
ES and LS LPG	-	-	14.5	9.0	-	-
VR	10.5	7.2	-	-	11.5	7.6
VR-X	10.5	7.4	-	-	11.5	7.6
AWD	-	-	-	-	11.5	7.2
VR AWD	-	-	-	-	12.0	7.6
ES WAGON	-	-	11.5	7.6	-	-
LS WAGON	-	-	11.5	7.6	-	-
VR WAGON	-	-	-	-	11.5	7.8
<small>These figures are obtained from controlled laboratory tests conducted by Mitsubishi Motors Australia Limited to Australian Standard AS2877 to meet Euro 2 emission standards and are provided to assist you in comparing the fuel consumption of Magna with other vehicles. The actual fuel consumption you achieve will depend, however, on many factors, including your driving habits, the prevailing conditions and your vehicle's equipment, condition and use.</small>						

TRANSMISSION			
Manual transmission	5 speed, all synchromesh, floor shift		
Auto transmission	4 speed INVECS II "Smart Logic" automatic transmission with 'SPORTS MODE' sequential gear shift		
	5 speed INVECS II "Smart Logic" automatic transmission with 'SPORTS MODE' sequential gear shift		
GEAR RATIOS			
	MANUAL	AUTOMATIC	AUTOMATIC
Ratio	5 speed	4 speed	5 speed
1st	3.333	2.842	3.789
2nd	2.105	1.495	2.057
3rd	1.407	1.000	1.421
4th	1.031	0.731	1.000
5th	0.804	-	0.731
Reverse	3.416	2.720	3.865
Final drive	3.736	3.269	3.684
AWD DRIVELINE RATIOS			
Transfer	0.301		
Centre differential	3.684		
Rear differential (LSD)	3.312		
BRAKES			
Power assisted four wheel discs			
Anti-lock Braking System (ABS) and Electronic Brakeforce Distribution (EBD)			
MAGNA ES, LS, VR, VR-X			
Front	276mm vented discs with single pot callipers		
Rear	258mm solid discs with single pot callipers		
MAGNA AWD and VR AWD – HIGH PERFORMANCE BRAKES			
Front	294mm vented discs with twin pot callipers (+18mm over standard)		
Rear	284mm vented discs with single pot callipers (+26mm over standard)		

MAGNA SPECIFICATIONS

SUSPENSION SEDAN	
Front	Independent McPherson strut with coil springs, lower A-arm and anti-sway bar
Rear	Independent multi-link with upper and lower control arms, coil springs, telescopic shock absorbers and anti-sway bar
WAGON	
Front	Independent MacPherson strut with lower A-arm and anti-sway bar
Rear	Tubular axle with four trailing arms, lateral locating rod, coil springs and telescopic shock absorbers
STEERING	
Power assisted rack and pinion	
TURNING CIRCLE	
11.2 metres	
DIMENSIONS INTERNAL (MM)	
Head room (front)	1001
Head room (rear)	952
Leg room (front)	1108
Leg room (rear)	947

TRUNK CAPACITY		
	470 litres (sedan)	2229 litres (wagon) ¹
KERB MASS KG		
	MANUAL	AUTOMATIC
ES	1508	1537
LS	–	1535
ES LPG	–	1538
LS LPG	–	1545
VR	1508	1547
VR-X	1532	1571
AWD	–	1648
VR AWD	–	1670
ES WAGON	–	1596
LS WAGON	–	1604
VR WAGON	–	1634
ELECTRICAL SYSTEM		
Battery	12V/430CCA	
Alternator	110A	
1. With seats folded down.		

DIMENSIONS EXTERNAL (MM)	ES	LS	VR	VR-X	AWD	VR AWD	LS WAGON	ES WAGON	VR WAGON	ES & LS LPG
Overall length	4860	4860	4860	4860	4860	4860	4846	4846	4846	4860
Overall width	1785	1785	1785	1785	1785	1785	1785	1785	1785	1785
Overall height	1435	1435	1422	1422	1435	1422	1497	1497	1497	1435
Wheelbase	2722	2722	2722	2722	2722	2722	2722	2722	2722	2722
Track										
front	1545	1545	1545	1545	1545	1545	1545	1545	1545	1545
rear	1535	1535	1535	1535	1535	1535	1505	1505	1505	1535
Ground clearance	158	158	158	165	158	158	165	165	165	158

MAGNA SPECIFICATIONS

MECHANICAL						
Power Train	ES	LS	AWD	VR	VR-X	VR AWD
3.5 litre V6 SOHC 24 valve MPI engine	•	•	•	•	•	•
Maximum power	155kW @ 5250 rpm	155kW @ 5250 rpm	154kW @ 5000 rpm	163kW @ 5200 rpm	163kW @ 5200 rpm	159kW @ 5500 rpm
Maximum torque	316Nm @ 4000 rpm	316Nm @ 4000 rpm	310Nm @ 4000 rpm	317Nm @ 4500 rpm	317Nm @ 4500 rpm	318Nm @ 4000 rpm
5 speed manual transmission (sedan only)	•	–	–	•	•	–
4 speed INVECS II 'Smart Logic' automatic transmission with 'SPORTS MODE' sequential gear shift	◦	•	–	–	–	–
5 speed INVECS II 'Smart Logic' automatic transmission with 'SPORTS MODE' sequential gear shift	–	–	•	◦	◦	•
LPG compatible engine	◦	•	–	–	–	–
Magna Monofuel LPG system ¹	◦	◦	–	–	–	–

1. Traction control is not available on AWD and LPG Monofuel models.

• standard ◦ optional – not available ◆ dealer fitted accessory

Mechanical	ES	LS	AWD	VR	VR-X	VR AWD
QuadTec™ AWD system	–	–	•	–	–	•
Traction and trace control with off switch ¹	–	•	–	•	•	–
Power assisted 4 wheel disc brakes Front – 276 mm vented disc with single pot callipers Rear – 258 mm solid disc with single pot callipers	•	•	–	•	•	–
Premium power assisted 4 wheel disc brakes Front – 294 mm vented disc with twin pot callipers Rear – 284 mm vented disc with single pot callipers	–	–	•	–	–	•
Anti-lock Braking System (ABS) with Electronic Brakeforce Distribution (EBD)	•	•	•	•	•	•
Limited slip differential	–	–	•	–	–	•
Automatic transmission and ignition interlock	–	–	•	–	–	•
Power assisted steering	•	•	•	•	•	•
Sports exhaust	–	–	–	•	•	•

MAGNA SPECIFICATIONS

MECHANICAL						
Suspension	ES	LS	AWD	VR	VR-X	VR AWD
Independent front suspension MacPherson strut with lower A-arm and anti-roll bar	•	•	•	•	•	•
Independent rear suspension – Independent multi-link with upper and lower control arms, coil springs and telescopic shock absorbers	•	•	•	•	•	•
Tubular axle with four trailing arms, lateral locating rod, coil springs and telescopic shock absorbers (wagon only)	•	•	–	•	–	–
Rear stabiliser bar	•	•	•	•	•	•
Sports tuned suspension	–	–	–	•	•	•
EXTERIOR						
Wheels	ES	LS	AWD	VR	VR-X	VR AWD
15" x 6" steel wheels. Full cover 205/65R15 95H Bridgestone RE92 tyres	•	–	–	–	–	–
15" x 6" five spoke alloy wheels 205/65R15 95H Bridgestone RE92 tyres	–	•	–	–	–	–
16" x 6" ten spoke alloy wheels 215/60R16 95H Turanza tyres	–	–	•	–	–	–
16" x 7" ten spoke alloy wheels 215/60R16 95H Turanza tyres	–	–	–	•	–	–
16" x 7" ten spoke alloy wheels 215/60R16 Grid II tyres	–	–	–	–	–	•
17" x 7" five spoke alloy wheels 225/50R17 Grid II tyres	–	–	–	–	•	–
Matching spare wheel	•	•	•	•	•	•

• standard ◦ optional – not available ♦ dealer fitted accessory

EXTERIOR CONTINUED						
Styling	ES	LS	AWD	VR	VR-X	VR AWD
Body coloured bumpers	•	•	•	•	•	•
Multi parabola headlamps	•	•	•	•	•	•
Door mirrors – electric (black)	•	–	–	–	–	–
Door mirrors – electric (body colour)	–	•	•	•	•	•
Outer door handles – body coloured	•	•	•	•	•	•
Radiator grille – sports style	–	–	–	–	•	–
Moulded mesh under grille	–	–	–	•	–	•
Steel wire mesh under grille	–	–	–	–	•	–
Body colour side protection mouldings	–	–	–	•	•	•
Chromed exhaust pipe	–	–	–	–	•	–
Mudflaps	♦	♦	♦	♦	♦	♦
Front fog lamps – sports style	–	–	–	•	–	•
Front fog lamps – shark eye style	–	–	–	–	•	–
Body kit – front, rear and side air dams	–	–	–	–	•	–
Deck lid spoiler – body colour	–	–	–	•	•	•
Tailgate air deflector (wagon only)	•	•	–	–	–	–
Roof spoiler – body colour (wagon only)	–	–	–	•	–	–
Roof rails (wagon only)	•	•	–	•	–	–
High mount stop lamp	•	•	•	•	•	•

MAGNA SPECIFICATIONS

INTERIOR						
Audio	ES	LS	AWD	VR	VR-X	VR AWD
AM/FM Radio/CD with security code and telephone mute ¹	•	•	•	•	–	•
AM/FM Radio, with in-dash 6 CD stacker, security code and telephone mute ¹	–	–	–	–	•	–
Satellite navigation system (sedan only)	◆	◆	◆	◆	◆	◆
Power antenna	•	•	•	•	•	•
Number of speakers (positions)	6 (4)	8 (6)	6 (4)	8 (6)	10 (8)	8 (6)
Styling						
Black surround on 'SPORTS MODE' automatic transmission gear shift	•	•	–	•	–	–
Chrome surround on 'SPORTS MODE' automatic transmission gear shift	–	–	–	–	•	–
Chrome surround on 'SPORTS MODE' automatic transmission gear shift with embossed AWD logo	–	–	•	–	–	•
Instrument meter – black dial	•	•	–	–	–	–
Instrument meter – black dial with AWD logo	–	–	•	–	–	–
Instrument meter – sports dial	–	–	–	•	–	–
Instrument meter – sports dial with VR-X logo	–	–	–	–	•	–
Instrument meter – sports dial with AWD logo	–	–	–	–	–	•
Warm silver centre console	–	–	–	–	•	–
'SPORTS MODE' indicator for automatic transmission	•	•	•	•	•	•

1. Telephone mute operational where hands-free phone kit accessories fitted.

INTERIOR CONTINUED						
Seating	ES	LS	AWD	VR	VR-X	VR AWD
Jacquard woven seat trim	•	–	•	–	–	–
Woven knit seat trim	–	•	–	–	–	–
Sporty Jacquard woven seat trim	–	–	–	•	–	•
Sporty Jacquard woven seat trim with metallic yarns featuring embroidered VR-X logo	–	–	–	–	•	–
Seat trim with black perforated leather back and cushion featuring embroidered VR-X logo and matching stitching	–	–	–	–	◦	–
Power driver's seat with slide, height and tilt adjustment	•	•	•	•	•	•
Driver's seat manual lumbar and recline adjustment	•	•	•	•	•	•
Passenger seat with manual slide and recline adjustment	•	•	•	•	•	•
Driver and passenger front seatbelt adjustable shoulder anchor	•	•	•	•	•	•
Height adjustable driver and passenger front seat head restraint	•	•	•	•	•	•
Integrated rear seat headrests	•	•	•	•	•	•
Seating capacity – five adults	•	•	•	•	•	•

• standard ◦ optional – not available ◆ dealer fitted accessory

MAGNA SPECIFICATIONS

INTERIOR CONTINUED						
Comfort	ES	LS	AWD	VR	VR-X	VR AWD
Automatic climate control air conditioning with rear outlets	•	•	•	•	•	•
Power windows front and rear. One touch down function on driver window.	•	•	•	•	•	•
Cruise control	•	•	•	•	•	•
Leather wrapped steering wheel	–	–	•	•	•	•
Two-tone embossed leather wrapped steering wheel ¹	–	–	–	–	◦	–
Leather wrapped gear shift	–	–	•	•	•	•
Rear seat centre armrest with boot access ²	•	•	•	•	•	•
Side window demisters in front doors	•	•	•	•	•	•
Electric glass sunroof (sedan only)	◦	◦	◦	◦	◦	◦
EZ-KOOL [®] tinted side and rear glass	•	•	•	•	•	•

1. Available only with leather option.
2. Boot access not available on Magna Monofuel models.

INTERIOR CONTINUED						
Safety	ES	LS	AWD	VR	VR-X	VR AWD
Driver SRS airbag in steering wheel	•	•	•	•	•	•
Front passenger SRS airbag	•	•	•	•	•	•
Driver and front passenger side SRS airbags	•	•	•	•	•	•
Driver and front passenger seatbelt pretensioners	•	•	•	•	•	•
Prismatic interior rear view mirror	•	•	•	•	•	•
Rear seat centre lap/sash seatbelt	•	•	•	•	•	•
Emergency door unlock – front and side impact	•	•	•	•	•	•
Child proof rear door locks	•	•	•	•	•	•
Child restraint anchor points	•	•	•	•	•	•
Rest reminder	•	•	•	•	•	•

• standard ◦ optional – not available ♦ dealer fitted accessory

MAGNA SPECIFICATIONS

INTERIOR CONTINUED						
Convenience	ES	LS	AWD	VR	VR-X	VR AWD
10 Function Trip Computer including: average speed, speed alarm, instant fuel consumption, average fuel consumption, total fuel used, distance to empty, time travelled, total distance travelled, rest reminder, service reminder	•	•	•	•	•	•
Electric door mirrors	•	•	•	•	•	•
Door courtesy lamps – front	–	•	–	•	•	•
Front map lamps and room lamp	–	•	–	•	•	•
Interior light activation on key removal	•	•	•	•	•	•
Vanity mirror – passenger	•	•	•	•	•	•
Six stage tilt adjustable steering column	•	•	•	•	•	•
Electric remote boot lid release for sedan	•	•	•	•	•	•
Remote fuel filler door release	•	•	•	•	•	•
Mobile phone preparation	•	•	•	•	•	•
Accessory socket	•	•	•	•	•	•
Variable instrument lighting dimmer	•	•	•	•	•	•
Tailgate assist handle (wagon only)	•	•	–	•	–	–
Convenience lamp in boot	•	•	•	•	•	•
Service reminder – appears 500 km before service is due	•	•	•	•	•	•

• standard ◦ optional – not available ♦ dealer fitted accessory

INTERIOR CONTINUED						
Security	ES	LS	AWD	VR	VR-X	VR AWD
Radio wave keyless entry featuring panic alarm	•	•	•	•	•	•
Central door locking (inc. tailgate on wagon)	•	•	•	•	•	•
Two stage door unlocking (first press opens driver's door only)	•	•	•	•	•	•
Cabin illumination for safe entry	•	•	•	•	•	•
Automatic relocking	•	•	•	•	•	•
Alarm – includes hood, trunk, tailgate and doors	•	•	•	•	•	•
Anti-theft encrypted immobilisation	•	•	•	•	•	•
Delayed headlamps off – programmable timer	•	•	•	•	•	•
Door lock in driver's door only	•	•	•	•	•	•
Steering lock	•	•	•	•	•	•
Flashing security lamp in radio	•	•	•	•	•	•
Storage						
Cup holder in console with lid (2)	•	•	•	•	•	•
Cup holder in rear armrest (2)	•	•	•	•	•	•
Passenger seat undertray	•	•	•	•	•	•
Glovebox with lamp	•	•	•	•	•	•
Cargo room lamp (wagon only)	•	•	–	•	–	–
Cargo floor carpet (wagon only)	•	•	–	•	–	–
One piece fold down rear seat (wagon only)	•	•	–	•	–	–

COLOUR RANGE

M = METALLIC P = PEARLESCENT Δ = ES AND LS ◇ = VR ∞ = VR-X



Mawson White Δ◇∞



Grange (M) Δ



Tanami (M) Δ



Pacific Blue (M) Δ



Kashmir (M) Δ



Sapphire Blue (P) Δ◇∞



Pewter (P) Δ \diamond ∞



Flame Red Δ \diamond ∞



Sienna Red (M) Δ \diamond ∞



Starlight (P) Δ



Sable (M) Δ \diamond ∞



Daintree Green (P) Δ \diamond ∞

MAGNA ACCESSORIES

Mitsubishi accessories add style, value and practicality to your vehicle. They're also a way of 'Adding your Spirit' by personalising your vehicle.

What's really important about Genuine Mitsubishi Accessories is that they're engineered and manufactured to the same exacting standards as your vehicle. The fit is precise and designed to complement your vehicle. It simply isn't worthwhile compromising your vehicle with imitations of Mitsubishi accessories.

Please check with your Mitsubishi dealer for specific model applications.



"Manta" – 15" Alloy Wheels



"Mako" – 16" Alloy Wheels



Five spoke 15" x 6" alloy wheels



Rainguards – sedan



Magna Sunguard – sedan



Satellite Navigation System – sedan

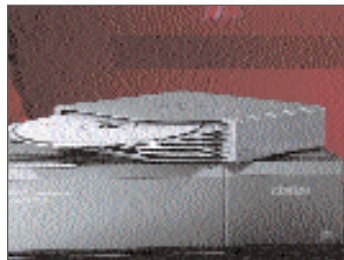

6 stacker CD – sedan



Performance Muffler – sedan



VR-X Style Spoiler – sedan



Sports Roof Racks – sedan



Parcel Net – sedan



Bootflap* – sedan

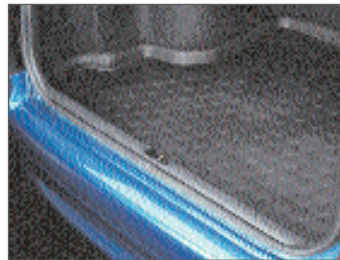

Plastic Bootliner – sedan



Floor Mats – VR-X sedan



Floor Mats – sedan and wagon

*Diamond Spectrum Accessories

Pictures are shown for illustration purposes and may not be product specific.



Floor Mats - VR -
sedan and wagon



Floor Mats - Ralliart - sedan



Floor Mats - AWD - sedan



Rubber Mats* - sedan and wagon

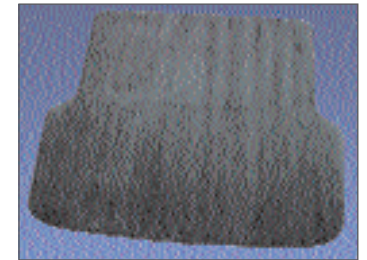

Rear Cargo Carpet Mat - wagon

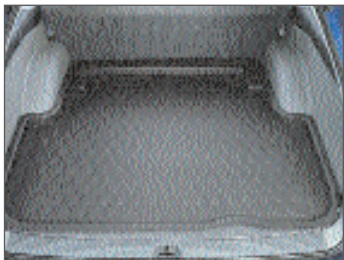

Rear Cargo Liner - wagon



Tie-down Net - wagon

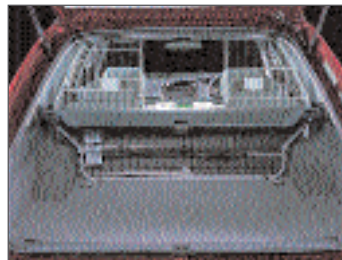

Cargo Barrier - wagon



Parcel Net - wagon



Cargo Blind - wagon

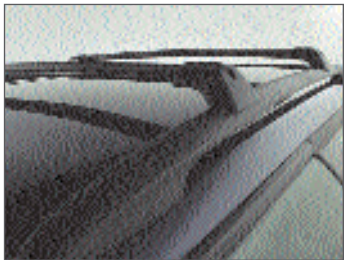

Roof Cross Bars - wagon



Locking Fuel Cap -
sedan and wagon



LPG Kit



Bonnet Protector -
sedan and wagon



Headlamp Protectors -
sedan and wagon

*Diamond Spectrum Accessories

MAGNA ACCESSORIES

Mitsubishi is committed to complete customer satisfaction. Therefore, when Genuine Mitsubishi Accessories are fitted to your new vehicle at time of delivery, they are covered by the Mitsubishi New Vehicle 3 year/ 100,000km Warranty. When they are fitted after you have purchased your new vehicle they are covered for the remainder of the new vehicle warranty or for 12 months/20,000km, whichever is the longer. In the case of Diamond Spectrum Accessories, the Warranty is 12 months/20,000km.

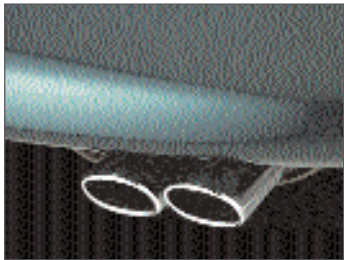

Chrome Exhaust Extensions* – sedan and wagon



Dash Mat* – sedan and wagon



Leather Steering Wheel – sedan and wagon



Mobile Phone Holder* – sedan and wagon



Ashtray – sedan and wagon



Standard towbar and towball 1500kg – sedan and wagon



Towbar and towball 1500kg – sedan and wagon (excl. VR-X)



Towbar and towball 1200kg – sedan and wagon

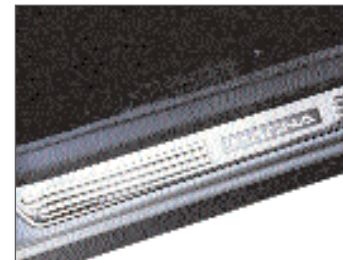

Scuff Plate* – sedan and wagon



Scuff Plate* – VR-X – sedan



Mudflaps – Front – sedan and wagon



Mudflaps – Rear – sedan and wagon



Locking wheel nuts* – sedan and wagon



Rola sports roof rack attachment* – sedan and wagon



Rola sports roof rack attachment* – bike carrier – sedan and wagon

*Diamond Spectrum Accessories

Pictures are shown for illustration purposes and may not be product specific.

MITSUBISHI RANGE



VERADA

The distinctive looking, new 2003 Verada continues to set the benchmark in quality and refinement. Verada comes with all the new features standard on Magna, plus a ten-way adjustable power driver's seat, traction control and a premium audio system with 6 disc, in-dash CD changer. Verada models include Ei (sedan and wagon), Xi, GTVi and AWD which boasts outstanding stability, superior roadholding and improved cornering control for safer, more spirited driving.



PAJERO

An undisputed offroad rally champion, Pajero delivers a powerful performance, renowned reliability, generous interior space and superior safety. Powered by a 3.8 litre V6 24 valve fuel injected engine, with the option of a 3.2 litre intercooled turbo direct injection diesel (Di-D), Pajero boasts a maximum towing capacity of 2500kg.



LANCER

The new CH Lancer takes Mitsubishi's rally-bred technology to the city streets in a distinct new look with a host of great features. The sporty VRX, with its bold rear spoiler and black interior, boasts 16" alloy wheels, a new strut brace for greater handling and 4 speed automatic transmission with 'SPORTS MODE' sequential gear shifting for hands on control from the new EVO type "Steer-matic" 3-spoke steering wheel.



CHALLENGER

A luxurious and sporty all terrain 4WD with advanced aerodynamic styling and superior ride comfort. Features a 3.0 litre V6, LPG compatible 24 valve multipoint fuel injected engine with an impressive maximum towing capacity of 2270kg. An undisputed offroad rally champion.



MIRAGE

This compact, 3 door hatch features a zippy 1.5 litre 12 valve, multi-point fuel injected engine. Available as a 5 speed manual or with INVECS II 'Smart Logic' 4 speed automatic transmission. Features include SRS driver's airbag, power steering, ample room and plenty of style.



OUTLANDER

A compact, 4WD offering a unique combination of sports styling, flexible interior space, ride comfort and unprecedented safety. Seats five people in comfort and features a range of cargo carrying options, while the automatic transmission boasts 'SPORTS MODE' sequential gear shifting.



NIMBUS

A stylish, award winning people mover. Nimbus comfortably seats seven adults with a variety of different seating and storage configurations. Powered by a 2.4 litre SOHC 16 valve, electronic multipoint fuel injected engine.



TRITON

A tough, hard working ute available in a range of powerful engine capacities and fuel types. The range of Triton models includes Cab Chassis, Double Cab and Club Cab.



EXPRESS

One of Australia's favourite light commercial vans, Express features petrol, LPG compatible and diesel engines in a choice of capacities. The range of body types includes Short Wheel Base (SWB), Medium Wheel Base (MWB), Window Van and Walk-Thru model (MWB).

Diamond Finance

Take the burden out of financing your new Mitsubishi vehicle with our competitive, reassuring and completely flexible range of finance products developed by Mitsubishi Motors Australia Ltd and St.George Motor Finance Limited.

Diamond Leasing

Our tailored fleet leasing services offer innovative, highly competitive features such as card purchasing, roadside assistance, specialist maintenance services, accident and claims management, optional insurance and more.

Diamond Road Side Assist

Peace of mind is guaranteed anywhere in Australia, 24 hours a day, 365 days a year with our fast, comprehensive, flexible roadside service offering assistance, repairs, towing and storage. Our Premium Roadside Assist clients also enjoy the added benefits of accommodation, medical and transport facilities.

Diamond Insurance

With the sound backing of Swann Insurance and Mitsubishi Motors Australia Ltd, Mitsubishi owners can choose between vehicle and personal protection solutions including motor vehicle, gapcover and loan protection insurance as well as a range of tailored warranty policies.

For more information on Diamond Products and Services contact your Mitsubishi Dealer.

Mitsubishi Motors Australia Ltd. offers a 3 year/100,000 kilometre New Vehicle Warranty and a 5 year Perforation Corrosion Warranty on Mitsubishi Magna. Always consult your authorised Mitsubishi Dealer for the latest details on specifications, options, prices, availability and conditions on New Vehicle Warranty. All product illustrations and specifications referred to herein are correct at the time of publication approval. Subject to any applicable Federal, State or Territory laws or ordinances which may apply from time to time. Mitsubishi Motors Australia Ltd. reserves the right, without notice or obligation, to discontinue or make changes to designs, specifications, colours and materials of the options and products referred to herein at any time without incurring any liability to any purchaser thereof. ©Mitsubishi Motors Australia Limited ABN 53 007 870 395 AUG '03 MMAL1639



