



MITSUBISHI
PAJERO



MITSUBISHI
MOTORS
engineered to excite



Australian Off Road
Championship
(Class 7)





TESTED BY THE BEST IN THE BUSINESS

At Mitsubishi our cars face the ultimate test - rally driving. The lessons learnt from driving on bone-shaking, suspension-shattering terrain gives all of our cars uncompromising durability and reliability. The Pajero is no exception.

Over forty years of rally championships around the world have become the testing grounds for production of Mitsubishi vehicles. Like the punishing desert terrain of the Dakar - the world's toughest off-road rally plus the Australian and World Rally Championships, where Mitsubishi vehicles have been consistent winners.

It's Mitsubishi's commitment to constantly evolving technology that has seen our cars win some of the world's toughest rally races time and time again. The Pajero is yet another chapter in a long-running history of performance vehicles that transcend the world of rally driving to excel at everyday motoring.



KING OFF-ROAD

Pajero innovations may start on the drawing board, but it's in the world's most impossible rally races that this legendary 4WD makes its greatest leaps forward. It has won the Dakar Rally an unequalled ten times in the last 20 years with its constantly evolving technology.

The lessons learnt give every Pajero its uncompromising toughness. Of course, Pajero has also triumphed on our native soil in the Australian Off Road Rally Championships. The only thing more terrifying than the competition is the harsh terrain of this world-famous series. The Pajero regularly chews up both and spits them out in its relentless ride to the chequered flag. It's a dirty job being the off-road champion, but someone has to do it.

PAJERO EXCEED

The Mitsubishi Pajero 4WD is fully equipped for your greatest adventure. Its power-plant is engineered for improved breathing efficiency, smoother performance and greater responsiveness. The 3.8 litre, Euro 3 compliant, 24-valve multi-point fuel injected V6 engine delivers superb power and torque when you need it. The 3.2 litre intercooled turbo-charged Direct Injection Diesel (Di-D) offers the raw power and effortless performance for any off-road adventure.

Pajero has the strength and safety of a one-piece shell monocoque body with integrated chassis, which is complemented with ABS brakes incorporating EBD.

The intelligent design within the cabin enables you to fold the 3rd row seats completely flat into the floor for uninterrupted rear visibility and greater luggage space.

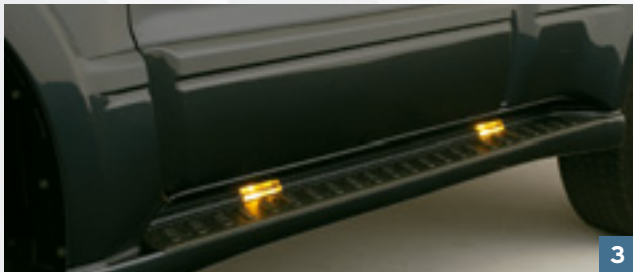

Or, if you prefer, remove the 3rd row to reveal a spacious hidden storage area. So, whether you are heading across the outback, or heading across town with the kids, the flexible passenger and cargo options ensure that everyone travels in safety and comfort.

The prestigious Pajero Exceed allows you to go anywhere in luxury. Additional exterior features include rear roof spoiler, a rear step integrated bumper and privacy glass.



- 1 Headlamp Washers
- 2 17" Alloy Wheels
- 3 Side Step Illumination







3:10
FUEL METER
1004 km
ALT METER
100 m
AUG. 06, 2005

WELLINGTON RD.
Wellington Rd/S18
W Proceed to Route

80 100 120 140 160 180 200



PAJERO EXCEED

Engineered for superior driver comfort, the Pajero Exceed features a sophisticated in-dash Multi-Media system. It includes satellite navigation, global positioning system (off-road mode), DVD, CD, MP3, TV tuner, rear reversing camera and a trip computer. Rear-seat passengers can enjoy their own entertainment system with a 7" full-colour screen and infra-red headphones, providing two distinct entertainment zones, so no passenger need compromise. Rear-seat passengers can also enjoy their own climate controls and roof-mounted air ducts to ensure complete passenger comfort.



The interior luxury and style are also enhanced by the leather-bound gearshift, transfer and parking brake lever, and a wood steering wheel with leather-bound panels. The Pajero Exceed's tilt-adjustable steering column and 8-way power-adjustable driver and passenger seats allow you to find your optimum driving position. Driver fatigue on those long journeys is lessened by effortless power steering and the cruise control features a convenient steering wheel mounted stalk. Not to mention the added safety of driver, passenger and side SRS airbags, so you can confidently focus on the adventure ahead.

- 1 Multi-Media
- Rear Reversing
Camera
- 2 Leather Seats
- 3 Multi-Media
- GPS
- 4 Multi-Media
- DVD/TV Tuner
- 5 Rear Seat DVD
Entertainment
System





PAJERO GLS

.....

The superbly engineered GLS also features colour-coded integrated side steps, chrome power door mirrors, body-coloured grille with chrome highlights, titanium-look dash with RV meter and privacy glass.

Safety is critical when travelling in the city and in the outback, which is why the GLS includes driver and passenger (side optional) SRS airbags, seatbelt pretensioners, 60:40 split 2nd row seats and lap sash seatbelt with headrests for all passengers.



- 1 Leather-bound Gearshifter and Transfer Lever
- 2 Rear Roof Spoiler
- 3 16" Alloy Wheels
- 4 Fog Lamps

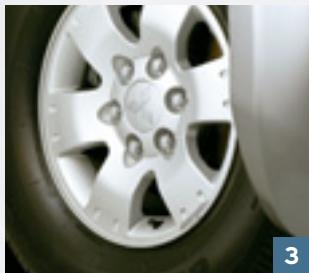







1

PAJERO GLX

Everyone in the family is looked after by the thoughtful features in the GLX, including driver and passenger (side optional) SRS airbags, seatbelt pretensioners, power steering, air conditioning, manual dual-height seat adjusters, power door mirrors and colour-coded bumpers.

Convenience and security are benefits on the GLX, with remote keyless entry, central locking and engine immobiliser, combined with child-protection locks on the rear doors. This quality package is complemented by the optional INVECS II 'Smart Logic' 5-speed automatic transmission with 'Sports Mode' sequential gearshifting, which is great for any adventure.



2

- 1 In-dash 6 CD Stacker
- 2 Third Row Seats Fold
- 3 Cruise Control
- 4 Power Windows



3



4

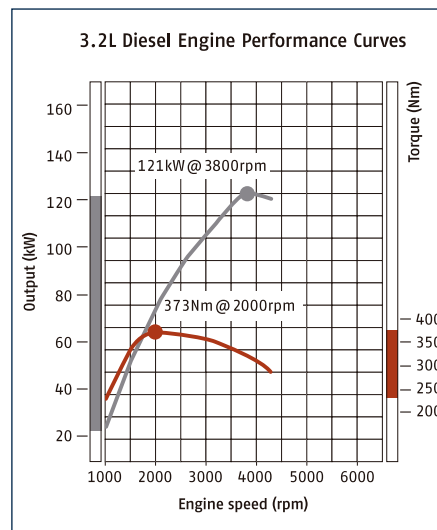

ENGINE POWER AND PERFORMANCE

UNCOMPROMISING DIESEL PERFORMANCE.

Pajero's 3.2 litre Turbo Direct Injection Diesel (Di-D) is the ultimate in off-road, heavy duty performance. The robust 3.2 litre Di-D DOHC 16-valve Intercooled Turbo Diesel engine optimises breathing efficiency to produce maximum torque of 373Nm at 2000rpm and power of 121kW at 3800rpm. It delivers all the inherent grunt of diesel for towing and low-end work plus satisfying power with low fuel consumption for cruising.

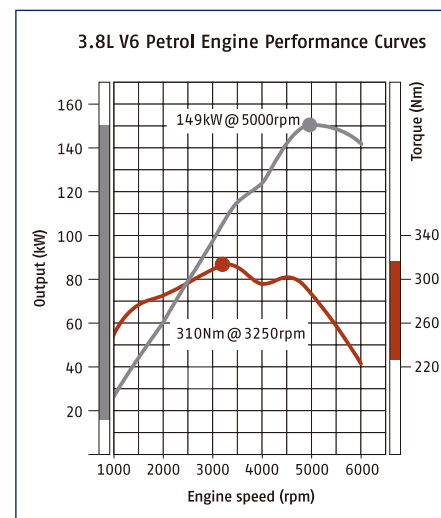
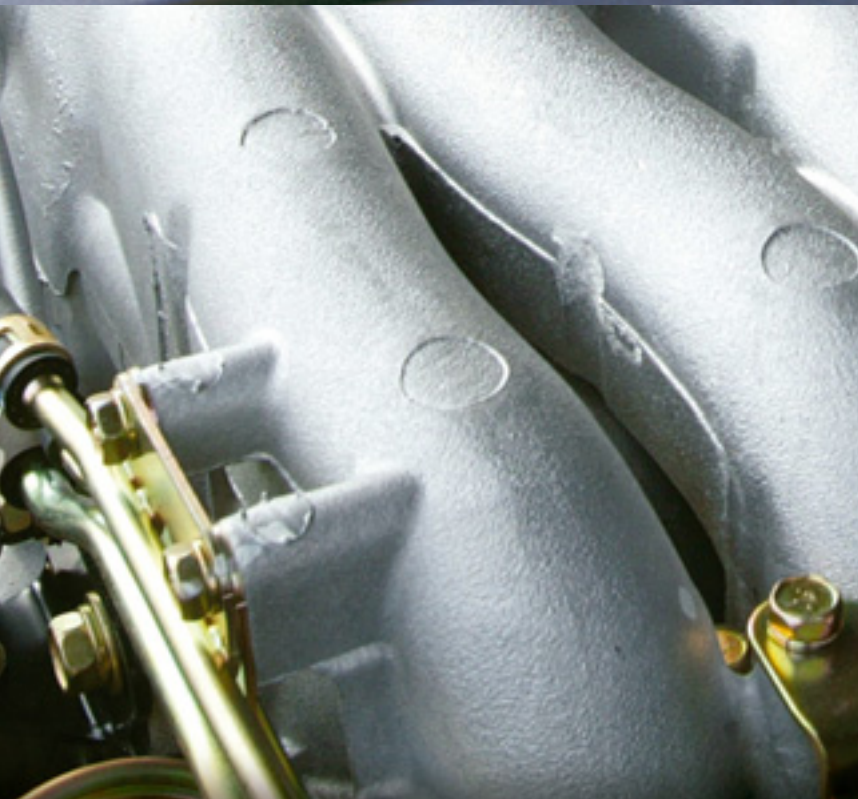

POWERFUL PETROL ENGINE.

The 3.8 litre, 24-valve multi-point fuel-injected V6 engine delivers smooth power and efficient fuel economy for cruising with plenty of torque for rugged, off-road driving. 149kW of power gives Pajero the muscle for easy overtaking on the highway, while a robust flat torque curve is maintained throughout the rev range peaking at 310Nm at a low 3250rpm.

MONOCOQUE BODY WITH INTEGRATED CHASSIS

Integral to Pajero is a Reinforced Impact Safety Evolution (RISE) monocoque body with integrated chassis that has come through the punishing ups and downs of the world's toughest rally like a true champion. It features a highly rigid cabin, impact-absorbing crushable zones, a lower centre of gravity and increased comfort.

The body structure is based around a one-piece shell with high levels of bending and torsional rigidity which provides a steel cage of safety for you and your passengers. With impact-absorbing crushable zones, the body is also reinforced at critical points delivering superior handling and performance.

Pajero's innovation offers the best of both worlds with a full-length chassis built into the super-strong body system. This ingenious design ensures you receive passenger car safety and handling with all the off-road prowess of a true rally champion.

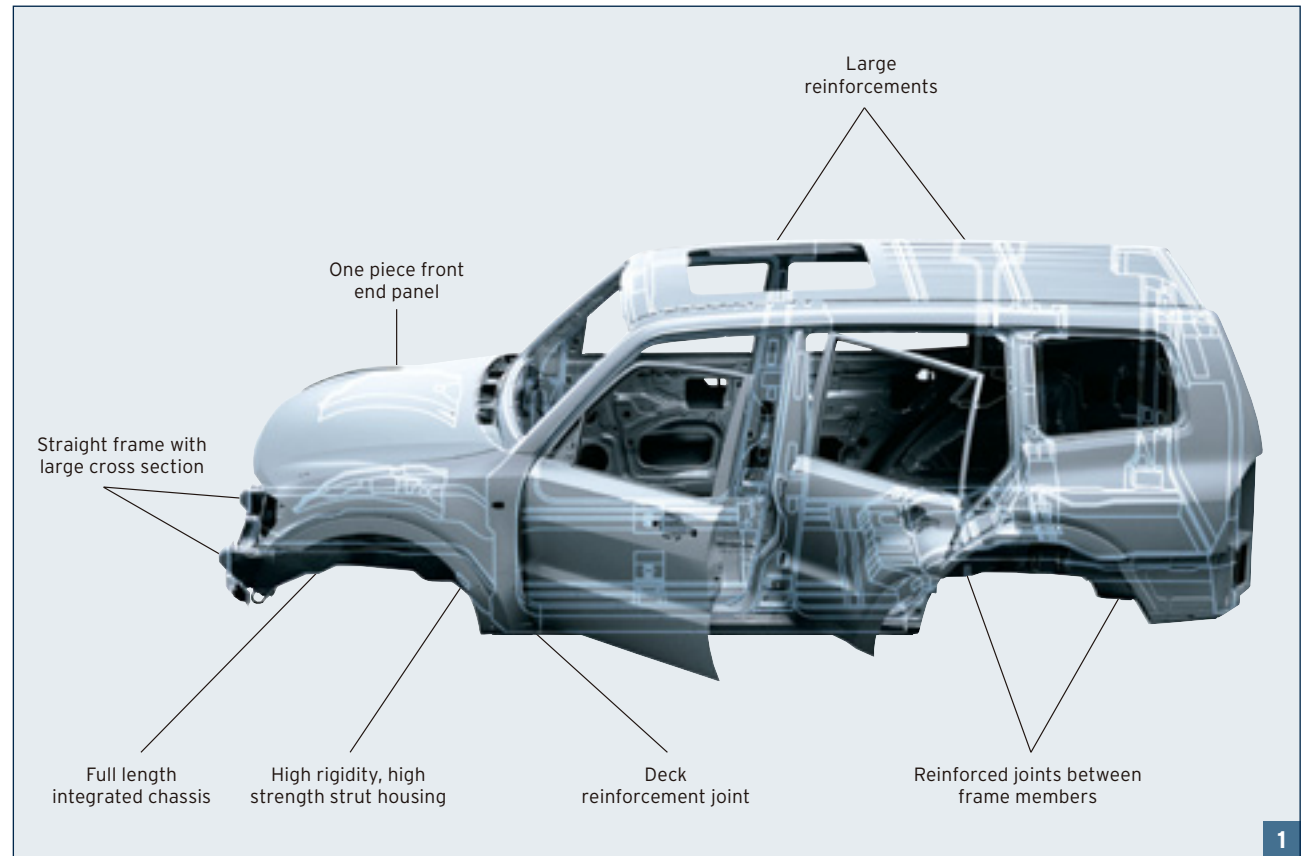

TECHNOLOGY AND SUSPENSION

Responsive handling, superior suspension, a super strong body design and outstanding ground clearance mean Pajero hugs windy country roads, easily ploughs through streams and safely traverses rocky terrain. It's this technology that has taken Pajero across the world's toughest finish lines in first place and tackles just about any adventure with ease.

- 1 Monocoque Body
- 2 4WD Ability
- 3 Suspension Frame
- 4 Front and Rear Suspension

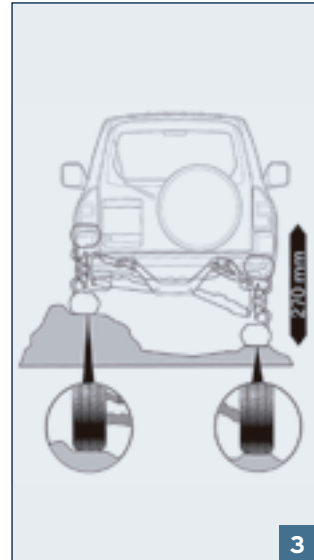
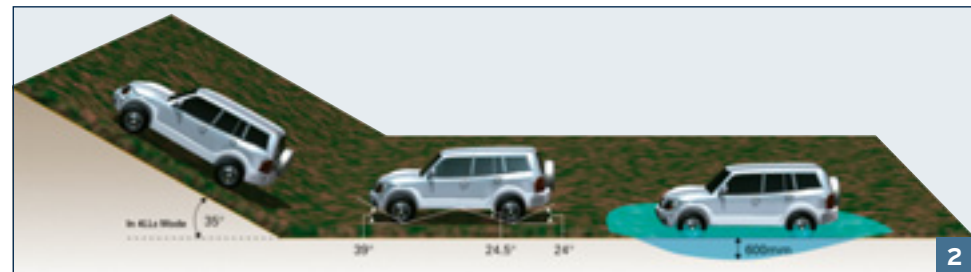

INDEPENDENT MULTI-LINK REAR SUSPENSION. For superior handling, Pajero boasts lighter independent multi-links with coil springs combined with increased suspension travel and track. This results in the uneven upper and lower arms delivering maximum tread contact on rough terrain, while minimising camber and track changes. The independent layout also reduces understeer and improves cornering stability to enhance ride comfort both on and off the road.

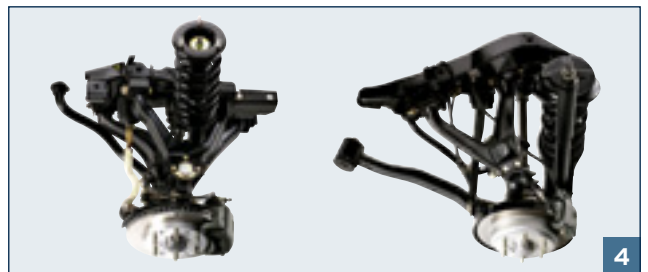



MITSUBISHI ALL TERRAIN TECHNOLOGY

Pajero has left the competition in the dust and continues to lead in safety and on- and off-road ability. The sophisticated MATT™ package, standard on all models, includes Multi-Mode Anti-Lock Braking System, Active Stability Control, Active Traction Control with Engine Brake Assist Control and Super Select II 4WD. With technology derived from testing and development on the torturous Dakar Rally and the ruthless Australian Off Road Rally Championship, MATT™ literally leaves no stone unturned to give you superior control.

SUPER SELECT II 4WD.

Super Select II offers full-time 4WD with selectable 2WD mode, which gives you the choice of efficient highway power and off-road traction whenever you want. This unique system allows you to alternate between 4WD and 2WD modes at speeds of up to 100km/h on any surface.



1

'SPORTS MODE'

AUTOMATIC TRANSMISSION.

When the 'Sports Mode' function is engaged the transmission computer monitors the engine speed to prevent potentially damaging or dangerous shifts, allowing drivers to manually shift gears without using a clutch. The advantage is that clutch-free operation reduces rev and torque loss usually associated with engaging and disengaging gears, maintaining precious momentum in off-road situations.

- 1 Super Select II 4WD
- 2 'Sports Mode' Shift Response Comparison
- 3 Multi-Mode ABS with EBD

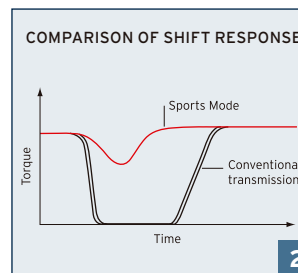

2

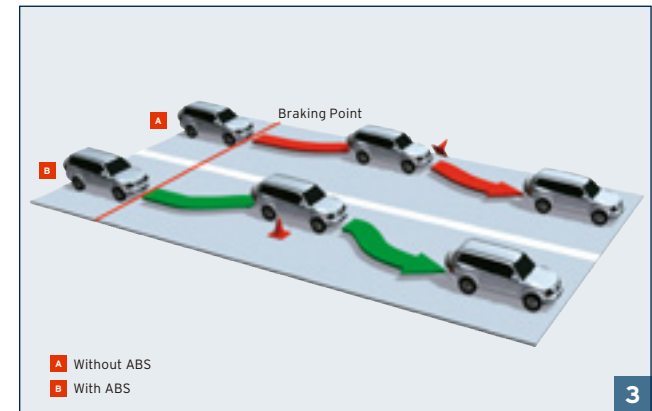

3

MULTI-MODE ABS WITH EBD.

Multi-Mode Anti-Lock Braking System (ABS) with Electronic Brakeforce Distribution (EBD). Large ventilated disc brakes front and rear give you maximum stopping power. You also have the reassurance of the multi-mode Anti-Lock Braking System (ABS) with Electronic Brakeforce Distribution (EBD).

This intelligent 4 channel, 4 sensor braking system monitors different wheel speeds and then activates the brakes to individual wheels when required to deliver superior control. The system is optimised for both 2WD and all 4WD modes.



2H (2WD HIGH RANGE)

For when you're cruising down the highway or just going across town, 2H mode shifts you into rear-wheel drive for smooth, quiet, fuel-efficient performance.



4H (FULL-TIME 4WD)

When the weather turns bad and the road gets rough, switch to 4H mode for added traction. The dynamic front/rear torque split adjusts between 33:67 and 50:50 to give you greater control for high-speed driving.



4HLc (4WD HIGH RANGE WITH LOCKED CENTRE DIFFERENTIAL)

Keeping you on track even in rugged or slippery conditions, the 4HLc mode distributes power equally to all four wheels for off-road excitement with a steady sense of control.



4LLc (4WD LOW RANGE WITH LOCKED CENTRE DIFFERENTIAL)

Switch to 4LLc when you need all the tractor-like crawling power Pajero is capable of. Maximised low-end torque pulls you through even the roughest terrain, stickiest mud and deepest snow.

ATC WITH EBAC.

Active Traction Control (ATC) with Engine Brake Assist Control (EBAC). No matter how slippery or rugged conditions get, stay in touch with Active Traction Control (ATC).

This intelligent system, which operates on all four wheels, replaces the need for a rear limited-slip differential by electronically sensing if one wheel is losing traction and then sending extra power to the other wheel with good traction - to keep you moving.

This system also includes Engine Brake Assist Control (EBAC) which ensures that engine braking and traction will not be lost due to spinning wheels when making a steep descent. This system works automatically when descending steep slopes in 4LLc mode.

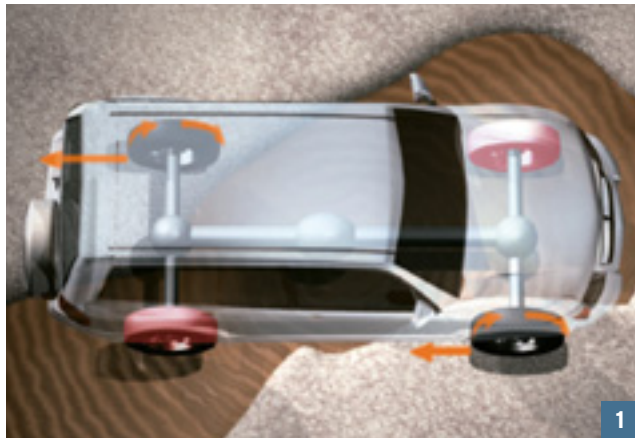

HILL HOLD CONTROL.

The hill hold function, which operates in 2nd gear, is a great assistance when tackling steep inclines. It enables the driver to stop on an incline without the risk of the vehicle rolling backwards or stalling, so you feel safer and more in control to carry on with your 4WD adventure.



INVECS II

ADAPTIVE SHIFT CONTROL GOING DOWNHILL

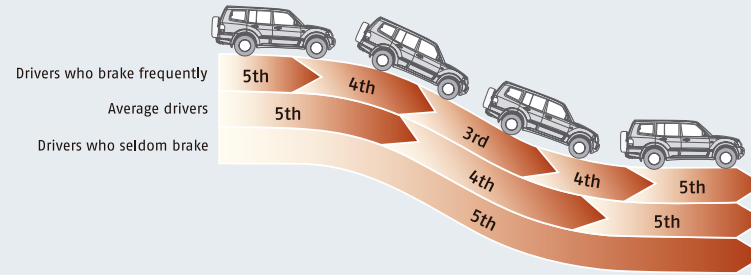

ADAPTIVE SHIFT CONTROL DURING ACCELERATION

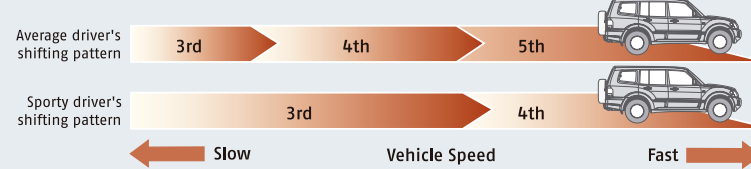

3

INVECS II 'SMART LOGIC' AUTOMATIC TRANSMISSION.

5-speed automatic with INVECS II 'Smart Logic'. To provide smoother shifting, the INVECS II 'Smart Logic' transmission system's on-board computer learns and adapts to each driver's preferences by recording engine and foot braking data. The control logic then adapts the gearshift timing to suit the driver's style while minimising torque fluctuation for effortless acceleration and a more predictable ride.

ASC.

Active Stability Control (ASC). ASC automatically recognises understeer or oversteer and applies braking to the diagonal wheel to keep you on line through corners. So you can confidently enjoy spirited driving while staying in complete control at every turn. The Active Stability Control (ASC) has an override switch for four-wheel driving in very sandy conditions.

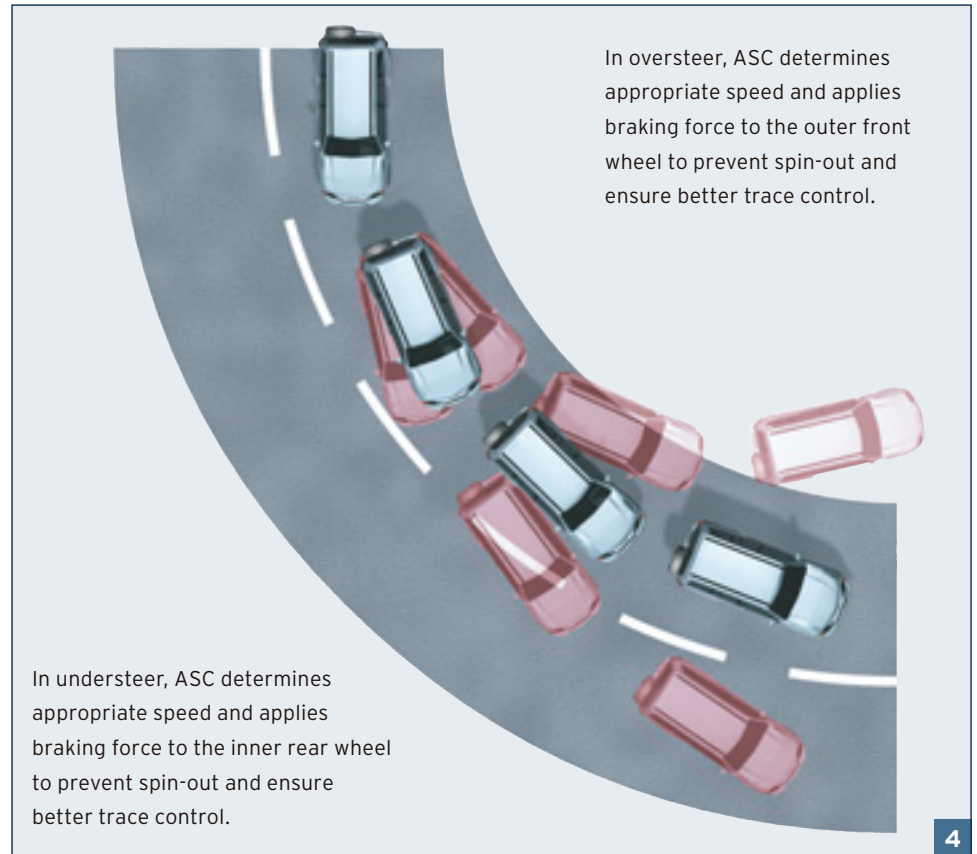

4

- 1 ATC with EBAC
- 2 Hill Hold Control
- 3 INVECS II
- 4 ASC

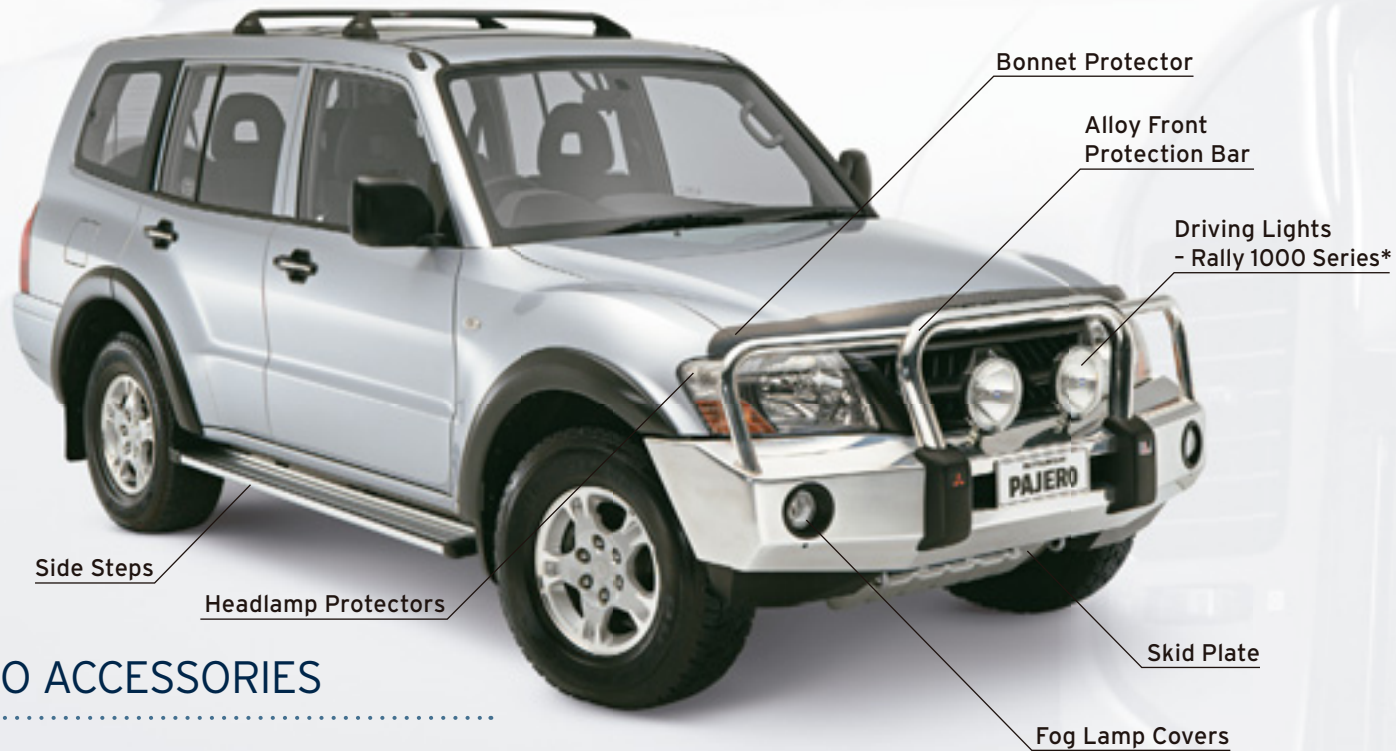

PAJERO ACCESSORIES

These are just some of the accessories available for your Pajero 4WD. For a complete list and further details of all accessories, contact your local Mitsubishi Dealer.

PAJERO ACCESSORIES INCLUDE:

- 1 Cargo Net
- 2 Cargo Carpet Mat
- 3 Cargo Liner
- 4 Cargo Barrier
- 5 Moulded Dash Mat*
- 6 Locking Wheel Nuts*
- 7 Door Handle Protectors
- 8 Grille Guard
- 9 Nudge Bar Alloy
- 10 Rear Extension Mirror
- 11 Driving Lights - Comet 500 Series*



1



2



3



4



5

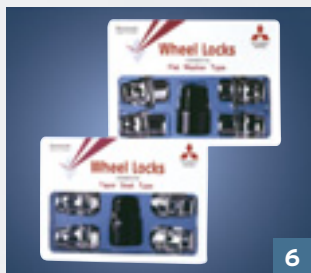

6



7



8



9



10



11

Rear Window Dust Deflector

Sports Roof Racks (60kg)

Towbar & Towball

Spare Wheel Cover Stainless*

Fender Flare

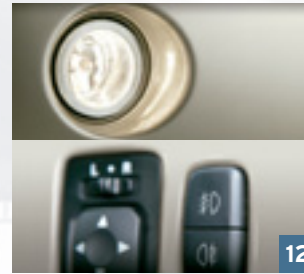

12



13



14



19



15



16



17



18



20



21



22



23



24



25

PAJERO ACCESSORIES INCLUDE:

- 12 Fog Lamp and Switch
- 13 Carpet Mat Set
- 14 Rubber Floor Mat Set*
- 15 Roof Rack Cross Bars (60kg)
- 16 Luggage Pod
- 17 Snorkel
- 18 Spare Wheel Cover Plastic - Colour-coded
- 19 Spare Wheel Cover Vinyl
- 20 Weathershield
- 21 Roof Spoiler
- 22 Front Scuff Plates*
- 23 Rear Scuff Plates*
- 24 Infrared Headphones
- 25 Rear DVD System

*Diamond Spectrum Accessories. Pictures are shown for illustration purposes and may not be product-specific. Please check with your Mitsubishi dealer for specific model applications. #Scheduled to be available October 2005.

PAJERO SPECIFICATIONS



PETROL ENGINE

3.8 litre, V6 SOHC 24-valve MPI	
Bore x stroke	95mm x 90mm
Capacity	3828cm ³
Compression ratio	9.5:1
Fuel system	ECI multi fuel inject - Euro 3 Compliant
Maximum power (DIN)	149kW @ 5000rpm
Maximum torque (DIN)	310Nm @ 3250rpm

DIESEL ENGINE

3.2 litre Di-D DOHC 16-valve Intercooled Turbo Diesel	
Bore x stroke	98.5mm x 105.0mm
Capacity	3200cm ³
Compression ratio	17.0:1
Fuel system	Electronic Direct Injection fuel pump Turbocharger with Intercooler
Maximum power	121kW @ 3800rpm
Maximum torque	373Nm @ 2000rpm

ELECTRICAL SYSTEM

	3.8L V6	3.2L Di-D
Battery	75D23L 520CCA/118RC	95D31L 622CCA/159RC
Voltage	12V	12V
Alternator	110 Amp	125 Amp
Starter motor	1.3kW (Manual) 1.4kW (Auto)	2.2kW

TRANSMISSION

5-speed manual transmission
5-speed automatic transmission with 'Sports Mode' sequential style shift change and INVECS II 'Smart Logic'

PETROL

	3.8L V6 Manual	3.8L V6 Auto
Ratios	First	4.234
	Second	2.238
	Third	1.398
	Fourth	1.000
	Fifth	0.819
	Reverse	3.553
Transfer ratio	High	1.000
	Low	1.900
Final drive		
Final gear ratio	4.300	4.300

DIESEL

	3.2L Di-D Manual	3.2L Di-D Auto
Ratios	First	4.234
	Second	2.238
	Third	1.398
	Fourth	1.000
	Fifth	0.760
	Reverse	3.553
Transfer ratio	High	1.000
	Low	1.900
Final drive		
Final gear ratio	4.100	3.917

CLUTCH

Manual	Single dry plate with hydraulic actuation
Automatic	3 element torque converter with lock-up

DRIVE TRANSFER SYSTEM

Type	"Super Select II" full-time 4WD system with selectable 2WD mode Auto front free-wheeling differential with synchromesh
------	---

BRAKES

Multi-mode Anti-lock Braking System (ABS) with Electronic Brakeforce Distribution (EBD)	
Front	Ventilated discs
Rear	Solid discs

SUSPENSION

Front	Independent - Double wishbone coil spring and stabiliser bar
Rear	Independent - Multi-link coil spring and stabiliser bar

STEERING

Type	Power-assisted rack and pinion
------	--------------------------------

WHEELS

GLX	16" x 7.0" alloy - 5-spoke
GLS	16" x 7.0" alloy - 6-spoke
EXCEED	17" x 7.5" alloy - 6-spoke
SPARE	Matching alloy spare wheel with wheel lock nut (mounted on rear tailgate)

TYRES*

GLX/GLS	265/70R-16 112S steel belted radial (HT)
Exceed	265/65R-17 112S steel belted radial (HT)

* The tyres fitted to Pajero as standard equipment are designed primarily for use on sealed roads. If your Pajero is to be driven primarily on unsealed roads, please consult your Mitsubishi dealer for advice on suitable tyre choices.

EXTERIOR DIMENSIONS (mm)

Overall height	1855	1855	1885
Overall length	4830	4830	4830
Overall width	1885	1895	1895
Track - front	1560	1560	1560
Track - rear	1560	1560	1560
Wheelbase	2780	2780	2780
Turning circle	11.4m	11.4m	11.4m

GROUND CLEARANCE (mm)

Ground clearance - V6 Petrol (unladen)	235	235	235
Ground clearance - Di-Diesel (unladen)	225	225	225
Fording depth	600	600	600
Approach angle	39.0°	39.0°	39.0°
Ramp breakover angle	24.5°	24.5°	24.5°
Departure angle	24.0°	24.0°	24.0°
Climbing angle	35.0°	35.0°	35.0°

INTERIOR DIMENSIONS (mm)

Front leg room	895	895	895
2nd row leg room	820	820	820
3rd row leg room	750	750	750
Front head room	950	950	950
2nd row head room	920	920	920
3rd row head room	860	860	860

LUGGAGE AREA (mm)

Length - 2nd row seat folded and 3rd row seat stowed	1495	1495	1495
Length - 2nd row seat upright and 3rd row seat stowed	845	845	845
Length - 2nd and 3rd row seat upright	205	205	205
Width	1405	1405	1405
Width at wheel arches	1030	1030	1030
Luggage area floor height	1105	1105	1105
Load floor height (from ground)	710	710	710



		GLX	GLS	EXCEED
CAPACITIES (kg)				
Gross vehicle mass	3.8L V6 Petrol (manual)	2760	2760	-
	3.8L V6 Petrol (auto)	2760	2760	2760
	3.2L Di-Diesel (manual)	2810	2810	-
	3.2L Di-Diesel (auto)	2810	2810	2810
Kerb mass	3.8L V6 Petrol (manual)	2085	2115	-
	3.8L V6 Petrol (auto)	2085	2115	2165
	3.2L Di-Diesel (manual)	2130	2170	-
	3.2L Di-Diesel (auto)	2130	2170	2220
Payload**	3.8L V6 Petrol (manual)	675	645	-
	3.8L V6 Petrol (auto)	675	645	595
	3.2L Di-Diesel (manual)	680	640	-
	3.2L Di-Diesel (auto)	680	640	590
Gross combination mass	3.8L V6 Petrol (manual)	5260	5260	-
	3.8L V6 Petrol (auto)	5260	5260	5260
	3.2L Di-Diesel (manual)	5310	5310	-
	3.2L Di-Diesel (auto)	5310	5310	5310
Maximum front axle load	All models	1200	1200	1200
Maximum rear axle load	All models	1650	1650	1650
Seating capacity	Front	2	2	2
	2nd row	3	3	3
	3rd row (70kg max per person)	2	2	2
	Total	7	7	7

** Payload includes occupants, fuel and fitted options (if any). The weight of these must be deducted from Payload to determine actual load-carrying capacity. Front and/or rear axle loads must not be exceeded.

MAXIMUM TOWING CAPACITY* (kg)				
With trailer brakes		2500	2500	2500
Without trailer brakes		750	750	750
Towball download		250	250	250

* Subject to State regulations and towbar designs. A Weight Distribution Hitch (WDH) is recommended for towball downloads exceeding 135kg. For further information refer to the Pajero Owner's Manual.

FUEL TANK CAPACITY				
Litres		90	90	90

FUEL CONSUMPTION				
(ADR81/01) (Litres per 100km)	3.8L V6 Petrol (manual)	13.6	13.6	-
	3.8L V6 Petrol (auto)	14.3	14.3	14.3
	3.2L Di-Diesel (manual)	9.6	9.6	-
	3.2L Di-Diesel (auto)	10.7	10.7	10.7

These figures are obtained from controlled laboratory tests conducted by Mitsubishi Motors to Australian Standard ADR81/01 and are provided to assist you in comparing the fuel consumption of Pajero with other vehicles. The actual fuel consumption you achieve will depend, however, on many factors, including your driving habits, the prevailing conditions and your vehicle's equipment, condition and use.



	GLX MANUAL	GLX AUTO	GLS MANUAL	GLS AUTO	EXCEED AUTO
MECHANICAL					
MATT™ (Mitsubishi All Terrain Technology)					
"Super Select II" full-time 4WD system inc. selectable 2WD mode	S	S	S	S	S
Synchronised auto front free-wheeling differential	S	S	S	S	S
Multi-Mode Anti-lock Braking System (ABS)					
with Electronic Brakeforce Distribution (EBD)	S	S	S	S	S
Active Traction Control	S	S	S	S	S
Active Stability Control	S	S	S	S	S
Engine Brake Assist Control	S	S	S	S	S
Hill Hold function (operates in 2nd gear)	-	S	-	S	S
ASC override switch	S	S	S	S	S
4WD modes 4H and 4HLc selectable at up to 100 km/h	S	S	S	S	S

SUSPENSION					
Independent - Double wishbone coil spring and stabiliser bar	S	S	S	S	S
Independent - Multi-link coil spring and stabiliser bar	S	S	S	S	S

EXTERIOR STYLING					
Front skid plate	S	S	S	S	S
Silver-coloured front skid plate	-	-	S	S	-
Fuel tank protector	S	S	S	S	S
Chrome power door mirrors	-	-	S	S	S
Body-coloured door handles	-	-	S	S	S
Windscreen wiper/washer with variable intermittent	S	S	S	S	S
Tailgate wiper/washer with fixed intermittent	S	S	S	S	S
Headlamp washers	-	-	-	-	S
Fog lamps (front)	A	A	S	S	S
Fog lamp (rear)	S	S	S	S	S
Front grille - body-coloured with chrome accents	-	-	S	S	S
Colour-coded front and rear bumper	S	S	S	S	S
Front (2) and rear (2) tow hooks	S	S	S	S	S
Colour-coded wheelarch flares	A	A	S	S	S
Colour-coded bodyside and tailgate cladding	-	-	S	S	S
Integrated side steps (colour-coded)	-	-	S	S	S
Side step illumination	-	-	-	-	S
Privacy glass (rear, quarter and tailgate windows)	-	-	S	S	S
Colour-keyed rear licence plate garnish	-	-	S	S	S
Rear roof spoiler	A	A	S	S	S
Roof rails	-	-	-	-	S
Roof racks	A	A	A	A	-
Roof rail cross bars	-	-	-	-	A
Front protection bar	A	A	A	A	A
Nudge bar	A	A	A	A	A
Driving lights	A	A	A	A	A



INTERIOR

	GLX MANUAL	GLX AUTO	GLS MANUAL	GLS AUTO	EXCEED AUTO
Audio					
Security coded AM/FM Radio with CD player	S	S	S	S	S
In-dash 6 CD stacker	S	S	S	S	-
Pillar mounted antenna	S	S	-	-	-
Power antenna with half-mast stop function	-	-	S	S	S
No. of speakers	4	4	4	4	6

MULTI-MEDIA

In-dash multi-function full-colour 6.5" media display screen	-	-	-	-	S
Satellite navigation***	-	-	-	-	S
Off-road navigation mode	-	-	-	-	S
Trip computer	-	-	-	-	S
Inclinometer	-	-	-	-	S
Rear-mounted reversing camera	-	-	-	-	S
TV tuner with glass-mounted antenna	-	-	-	-	S
DVD/VCD/MPEG player	-	-	-	-	S
MP3 compatible CD player	-	-	-	-	S
Multi-media remote control	-	-	-	-	S
Roof-mounted full colour 7" rear DVD screen (MP3, VCD & CD compatible)	A	A	A	A	S
Wireless headphones for rear DVD unit	A	A	A	A	S [^]
Remote rear DVD control	A	A	A	A	S
Rear television display	-	-	-	-	S

*** Satellite navigation mapping covers most established roads and highways as at software release date. Proposed and new road developments are not contained in the system software.

[^] 2 x Wireless headphones standard on Exceed.

INTERIOR STYLING

Leather-bound steering wheel	-	-	S	S	-
Wood and leather-bound steering wheel	-	-	-	-	S
Titanium look instrument panel and air conditioning outlets	-	-	S	S	-
Woodgrain look instrument panel and air conditioning outlets	-	-	-	-	S
Leather-wrapped gearshift knob, transfer lever and park brake lever	-	-	S	S	S
Titanium look gearshift and transfer lever panel surrounds	-	-	S	S	S
Instrument meters with twin digital trip meter, 4WD mode indicator, door ajar indicator	S	S	S	S	S
Digital clock (in dash)	S	S	-	-	-
RV meter - external temperature, digital clock, date, compass, barometer, altimeter	-	-	S	S	S
Climate control settings display in RV meter	-	-	-	-	S
Embroidered carpet mats (front and rear)	A	A	A	A	S
Stainless steel scuff plates	A	A	A	A	A

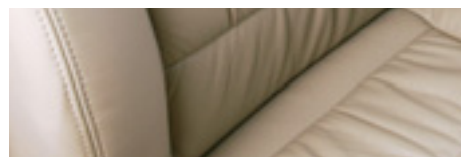



SAFETY

	GLX MANUAL	GLX AUTO	GLS MANUAL	GLS AUTO	EXCEED AUTO
Driver and front passenger SRS airbags	S	S	S	S	S
Side SRS airbags	O	O	O	O	S
3-point ELR seatbelts (all seating positions)	S	S	S	S	S
Seatbelt pretensioners (front) with load limiters	S	S	S	S	S
Day/night rear-view mirror	S	S	S	S	S
Side door impact beams	S	S	S	S	S
Childproof rear door locks	S	S	S	S	S
Child restraint anchor points	3	3	3	3	3
Rear-mounted reversing camera with in-dash display screen	-	-	-	-	S

SEATING

Cloth seat trim	S	S	-	-	-
Velour seat trim	-	-	S	S	-
Leather seating surfaces (leather look on 3rd row)	-	-	-	-	S
Front seats					
Dual height adjuster for driver's seat	S	S	S	S	-
Power driver and passenger seat with 8-way adjustment	-	-	-	-	S
Height adjustable seat belt anchors	S	S	S	S	S
Height and tilt adjustable see-through type headrests	S	S	S	S	S
Heated seat warmers	-	-	-	-	S
2nd row seats					
60:40 split folding function	S	S	S	S	S
Reclining adjuster and tumble type fold-up function	S	S	S	S	S
Height and tilt adjustable see-through type headrests in outboard positions (solid type in centre)	S	S	S	S	S
3rd row seats					
Front facing bench seat	S	S	S	S	S
Folding/stowable function (folds flat into underfloor compartment)	S	S	S	S	S
Removable from vehicle	S	S	S	S	S
Removable and height adjustable see-through type headrests	S	S	S	S	S

	GLX MANUAL	GLX AUTO	GLS MANUAL	GLS AUTO	EXCEED AUTO
COMFORT AND CONVENIENCE					
Air conditioning	S	S	S	S	S
Climate control air conditioning with display - dual zone (front & rear)	-	-	-	-	S
Rear climate controls and roof-mounted air ducts	-	-	-	-	S
Rear seat heater ducts	S	S	S	S	S
Power windows front and rear with driver auto down function and key off power delay	S	S	S	S	S
Cruise control	S	S	S	S	S
Power door mirrors	S	S	S	S	S
Tilt adjustable steering column	S	S	S	S	S
Interior lamp with time delay and front map lamps	S	S	S	S	S
Rear passenger reading lamps	S	S	S	S	S
Convenience lamp in luggage area	S	S	S	S	S
Front windscreen sunshade band	-	-	S	S	S
Door-mounted hazard lamps	S	S	S	S	S
Ignition key illumination	S	S	S	S	S
Variable instrument lighting dimmer	S	S	S	S	S
In-dash indicator for automatic transmission position	-	S	-	S	S
Headlamps "ON" - audible warning buzzer	S	S	S	S	S
Warning lamps include door/tailgate ajar, ATC wheel operation and low fuel	S	S	S	S	S
High-rise front centre armrest - with forward adjustable slide position (cloth trimmed)	S	S	S	S	-
High-rise front centre armrest - with forward adjustable slide position (leather trimmed)	-	-	-	-	S
Leather-bound glove box compendium	-	-	-	-	S
Accessory power sockets in front floor console and luggage area	S	S	S	S	S
Passenger-assist handles	5	5	5	5	5
Passenger grab handles	4	4	4	4	4
Sunvisor with ticket holder and vanity mirror	S	S	-	-	-
Sunvisor with extension, vanity mirror, lamp and lid - cloth-covered	-	-	S	S	S
Rear window demister	S	S	S	S	S
Remote fuel filler door release	S	S	S	S	S
Premium Diamond Road Side Assistance	A	A	A	A	S

	GLX MANUAL	GLX AUTO	GLS MANUAL	GLS AUTO	EXCEED AUTO
SECURITY					
Central door locking (incl. tailgate) with remote keyless entry and auto relock function	S	S	S	S	S
Cabin illumination on unlock	S	S	S	S	S
Automatic cabin illumination on key removal	S	S	S	S	S
Anti-theft encrypted engine immobilisation	S	S	S	S	S
Flashing security lamp in security-coded radio	S	S	S	S	-
Security-coded Multi-Media and rear entertainment system	-	-	-	-	S
STORAGE					
Cupholders	5	5	5	5	5
Driver and passenger seat back pocket	S	S	S	S	S
Front door trim map pockets	S	S	S	S	S
Upper glove box	S	S	S	S	S
Lockable lower glove box with illumination	S	S	S	S	S
Coin tray	S	S	S	S	-
Centre storage console with upper and lower compartments	S	S	S	S	S
Coat hooks	2	2	2	2	2
Mobile phone storage tray	S	S	S	S	S
Luggage tie-down hooks	4	4	4	4	4
Tailgate pocket with net	S	S	S	S	S
Luggage area storage compartment	S	S	S	S	S
Underfloor storage compartment	S	S	S	S	S
Fully trimmed cargo area and tailgate	S	S	S	S	S
Leather glove box compendium	-	-	-	-	S

COLOUR RANGE AND TRIM

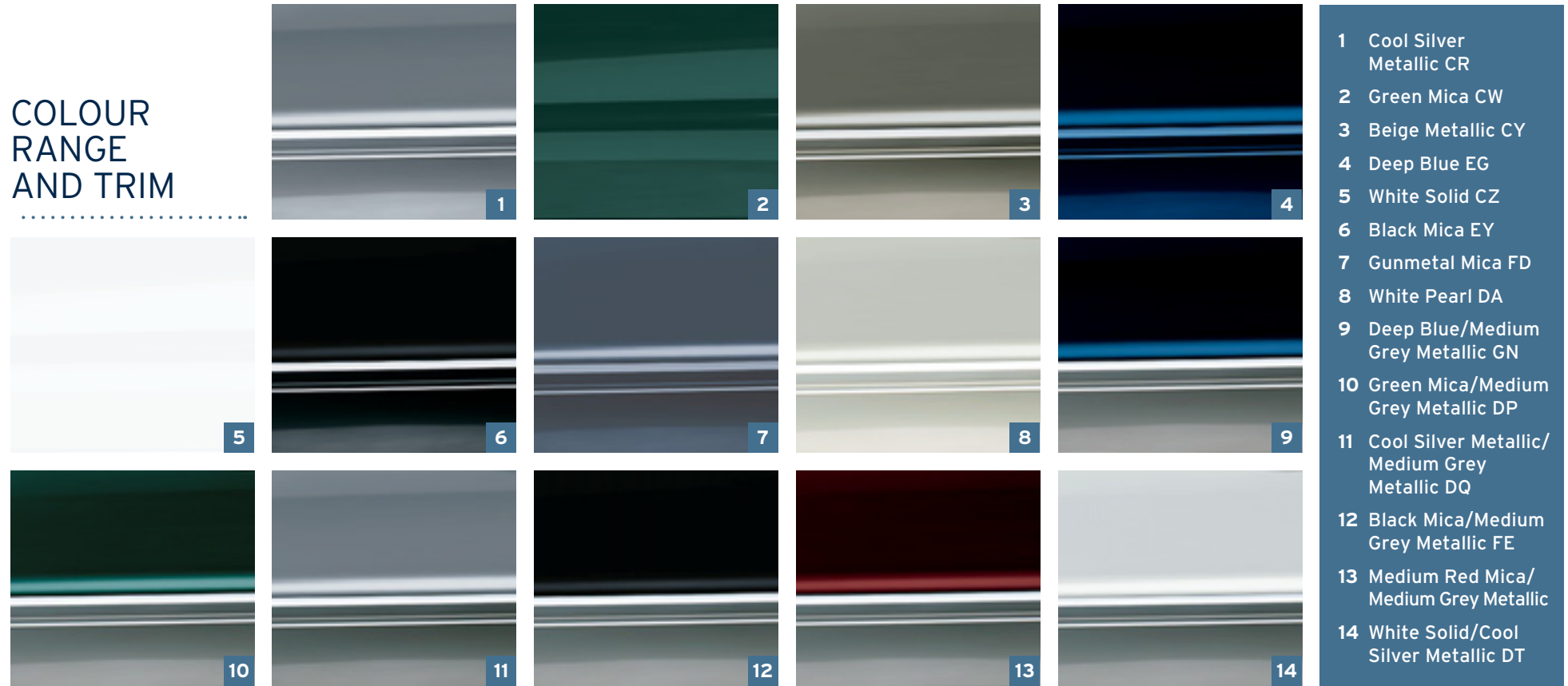

- 1 Cool Silver Metallic CR
- 2 Green Mica CW
- 3 Beige Metallic CY
- 4 Deep Blue EG
- 5 White Solid CZ
- 6 Black Mica EY
- 7 Gunmetal Mica FD
- 8 White Pearl DA
- 9 Deep Blue/Medium Grey Metallic GN
- 10 Green Mica/Medium Grey Metallic DP
- 11 Cool Silver Metallic/Medium Grey Metallic DQ
- 12 Black Mica/Medium Grey Metallic FE
- 13 Medium Red Mica/Medium Grey Metallic
- 14 White Solid/Cool Silver Metallic DT

- 1 GLX Cloth Blast Fabric/ Neo Backskin Knit
- 2 GLS Cloth Brook Fabric/ Neo Backskin Knit
- 3 EXCEED Leather Cool - Black Leather Inserts
- 4 EXCEED Leather Warm - Sandstone Leather Inserts

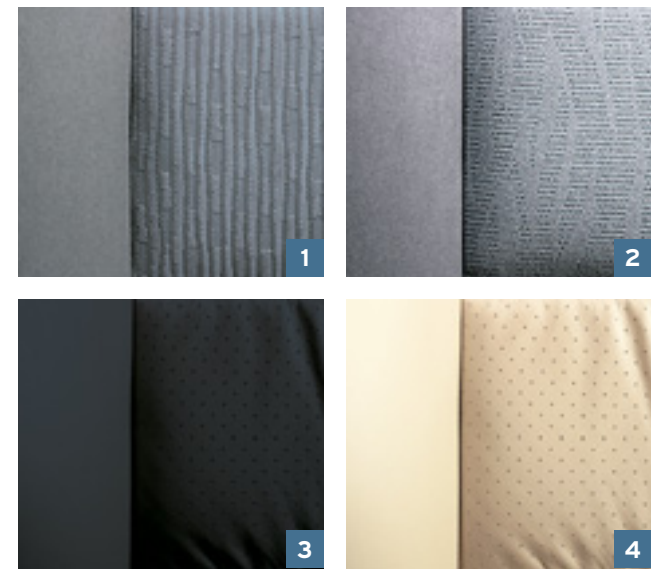

	CODE	GLX CLOTH	GLS CLOTH	EXCEED LEATHER COOL	EXCEED LEATHER WARM
MONOTONE COLOURS					
Cool Silver Metallic	CR	S	S	S	-
Green Mica	CW	S	S	S	S
Beige Metallic	CY	S	S	S	S
Deep Blue	EG	S	S	S	-
White Solid	CZ	S	-	-	-
Black Mica	EY	S	S	S	S
Gunmetal Mica	FD	S	S	S	-
White Pearl	DA	-	S	S	-
TWO-TONE COLOURS					
Deep Blue/Medium Grey Metallic	GN	-	S	S	-
Green Mica/Medium Grey Metallic	DP	-	S	S	S
Cool Silver Metallic/Medium Grey Metallic	DQ	-	S	S	-
Black Mica/Medium Grey Metallic	FE	-	S	S	S
Medium Red Mica/Medium Grey Metallic	DS	-	S	S	S
White Solid/Cool Silver Metallic	DT	-	S	S	S

Metallic and Pearlescent paints are optional extra. S : standard - : not available



BETTER BUILT
BETTER BACKED

Your Mitsubishi vehicle is manufactured using the latest automotive engineering techniques and the most advanced methods of quality control to provide you with many years of motoring enjoyment.

VEHICLE WARRANTY

Mitsubishi Motors Australia Limited offers a 5 year/130,000km* New Vehicle Warranty, a 10 year/160,000km* Powertrain Warranty† and a 5 year Perforation Corrosion Warranty on all Mitsubishi cars and light commercial vehicles.

ACCESSORIES WARRANTY

Mitsubishi Motors Australia is committed to complete customer satisfaction. Therefore, when Genuine Mitsubishi Accessories are fitted to your new vehicle at time of delivery, they are covered by the Mitsubishi 3 year/130,000km* Warranty. When they are fitted after purchase of your new vehicle they are covered for the remainder of the warranty or for 12 months/20,000km*. In the case of Diamond Spectrum Accessories, the Warranty is 12 months/20,000km*.

Diamond Finance

Take the burden out of financing your new Mitsubishi vehicle with our competitive, reassuring and completely flexible range of finance products developed by Mitsubishi Motors Australia Limited and St. George Motor Finance Limited.

Diamond Road Side Assist

Peace of mind is guaranteed anywhere in Australia, 24 hours a day, 365 days a year with our fast, comprehensive, flexible roadside service offering assistance, repairs, towing and storage. Our Premium Road Side Assist clients also enjoy the added benefits of accommodation, medical and transport facilities.

Diamond Leasing

Our tailored fleet leasing services offer innovative, highly competitive features such as card purchasing, roadside assistance, specialist maintenance services, accident and claims management, optional insurance and more.

Diamond Insurance

With the sound backing of Swann Insurance and Mitsubishi Motors Australia Limited, Mitsubishi owners can choose between vehicle and personal protection solutions including motor vehicle, gap cover and loan protection insurance as well as a range of tailored warranty policies.



CUSTOMER RELATIONS

Please contact Mitsubishi Motors Australia Customer Assistance Centre on 1300 13 12 11 for any further information or the location of your nearest Mitsubishi Dealer.

Always consult your authorised Mitsubishi Dealer for the latest details on specifications, options, prices, availability and conditions on New Vehicle Warranty. All product illustrations and specifications referred to herein are correct at the time of publication approval. Subject to any applicable Federal, State or Territory Laws or ordinances, which may apply from time to time, Mitsubishi Motors Australia Limited reserves the right, without notice, or obligation, to discontinue or make changes to designs, specifications, colours and materials of the options and products referred to herein at any time without incurring any liability to any purchaser thereof.
© Mitsubishi Motors Australia Limited. ABN 53 007 870 395. PAJNP0508

*Whichever occurs first. †Non-transferable.



**MITSUBISHI
MOTORS**
engineered to excite