



Audi

A6 allroad quattro





More beautiful.



Design.

How can a thing of beauty become even more beautiful?

By making it exceptional. With sporty elegant lines that make you think of an athlete at the peak of fitness. With a front whose distinctive single frame radiates self-confidence and assertiveness. With a robust stainless steel underride guard. With distinctive bumpers. With extra-wide wheel arches and accentuated door strips. In short, with the elegance of an Avant and the strength of character of an off-roader.





More flexible.

Higher.





Interior.

Bigger does not only mean "bigger". Bigger means more: more space. More flexibility. More possibilities. You can see this, for example, in the unique Falkirk Wheel in Scotland: a boat lift that rotates around its own axle and can lift up to eight boats at the same time.

Or in the Audi A6 allroad quattro which is not satisfied with just its impressive 1,600 litres of luggage space. It also has a flexible loading floor which can be set up, folded down to the rear or removed completely. A tailgate that can optionally be opened and closed automatically at the touch of a button. A track system with lashing eyes to hold the luggage. And – for even more space – roof rails for carrying bicycles, surfboards or other sports equipment.





Interior Details.

A beautiful room can be a pleasurable experience. So it is in the Audi A6 allroad quattro. This is created with wood, cloth, leather and alcantara trim. Controls that are both sporty and functional. The central MMI® operating concept with which you can control many of the car's systems as well as the communications and entertainment electronics comfortably at the touch of a button. And a range of equipment that makes the already high level of comfort even better. So that it will always be an experience when you get into the Audi A6 allroad quattro.



Safer.



In motorsport they put a safety car on the track when they have to reduce the risk in a potentially dangerous situation. On the road we are further than that – in the Audi A6 allroad quattro the safety is already in the car.

So, for example, active safety comes as standard with the Electronic Stabilization Programme ESP. The permanently active system improves roadholding by reducing the risk of skidding.





Further.

Model	A6 allroad quattro 3.2 FSI		A6 allroad quattro 4.2 FSI		A6 allroad quattro 2.7 TDI with/without diesel particulate filter		A6 allroad quattro 3.0 TDI with/without diesel particulate filter	
Engine type	V6-cylinder petrol engine with direct fuel injection		V8-cylinder petrol engine with direct fuel injection		V6-cylinder diesel engine with common rail injection system and exhaust gas turbocharger		V6-cylinder diesel engine with common rail injection system and exhaust gas turbocharger	
Displacement in cc (valves per cylinder)	3123 (4)		4163 (4)		2698 (4)		2967 (4)	
Max. output kW(hp) at rpm	188 (255)/6500		257 (350)/6800		132 (180)/3300–4500		171 (233)/4000	
Max. torque Nm at rpm	330/3250		440/3500		380/1400–3300		450/1400–3250	
Driveline/wheels								
Layout	quattro® permanent all-wheel drive		quattro® permanent all-wheel drive		quattro® permanent all-wheel drive		quattro® permanent all-wheel drive	
Transmission	6-speed manual transmission [6-speed tiptronic]		[6-speed tiptronic]		[6-speed tiptronic]		6-speed manual transmission [6-speed tiptronic]	
Wheels	Cast aluminium wheels, 8 J x 17		Cast aluminium wheels, 8 J x 18		Cast aluminium wheels, 8 J x 17		Cast aluminium wheels, 8 J x 17	
Tyres	225/55 R 17		245/45 R 18		225/55 R 17		225/55 R 17	
Weights/capacities								
Unladen weight¹ kg	1760	[1800]	[1880]	[1875]	1865	[1880]		
Gross vehicle weight kg	2390	[2430]	[2510]	[2505]	2495	[2510]		
Roof load/trailer nose weight kg	100/85		100/85		100/85		100/85	
Trailer weight² kg	unbraked	750	[750]	[750]	[750]	750	[750]	
	12% gradient	1900	[1900]	[2100]	[1900]	1900	[1900]	
	8% gradient	2100	[2100]	[2100]	[2100]	2100	[2100]	
Fuel tank approx. l	80		80		80		80	
Performance/consumption³								
Top speed km/h	242	[240]	[250] ⁴	[215]	231	[230]		
Acceleration 0-100 km/h in s	7.2	[7.7]	[6.3]	[9.3]	7.5	[7.8]		
Fuel grade	Super unleaded 95 RON ⁵		SuperPlus unleaded 98 RON ⁶		Diesel to EN 590		Diesel to EN 590	
Fuel consumption⁷ in l/100 Km	Urban	– ⁸	[–] ⁸	[–] ⁸	[–] ⁸	[–] ^{8, 10}	– ⁸	– ^{8, 10}
	Extra-urban	– ⁸	[–] ⁸	[–] ⁸	[–] ⁸	[–] ^{8, 10}	– ⁸	– ^{8, 10}
	Combined	11.2 ⁹	[11.0] ⁹	[11.2] ⁹	[8.7] ⁹	[8.6] ^{9, 10}	8.4 ⁹	8.3 ^{9, 10}
CO₂ emissions⁷ in g/km	Urban	– ⁸	[–] ⁸	[–] ⁸	[–] ⁸	[–] ^{8, 10}	– ⁸	– ^{8, 10}
	Extra-urban	– ⁸	[–] ⁸	[–] ⁸	[–] ⁸	[–] ^{8, 10}	– ⁸	– ^{8, 10}
	Combined	269 ⁹	[264] ⁹	[269] ⁹	[230] ⁹	[227] ^{9, 10}	221 ⁹	219 ^{9, 10}
Exhaust standard	EU4		EU4		EU4		EU4	

[] Information for tiptronic. Explanatory notes ¹ to ¹⁰ on page 47.

A6 allroad quattro

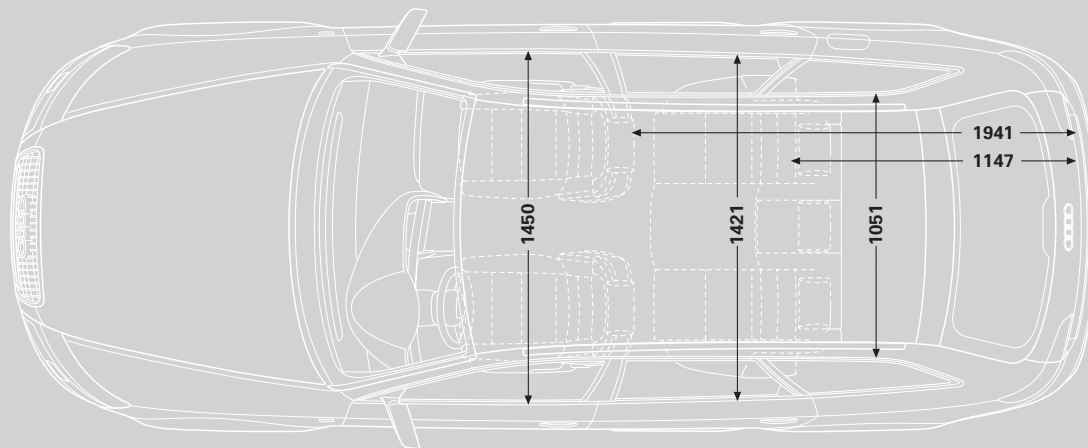
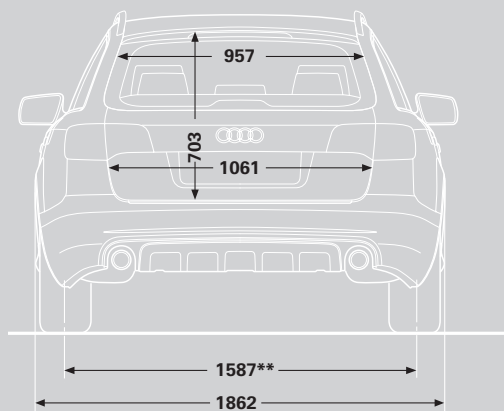
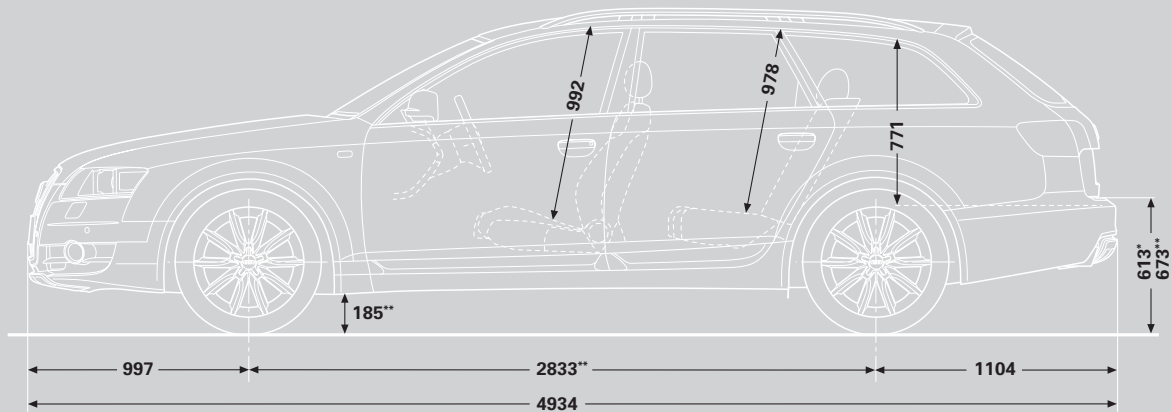
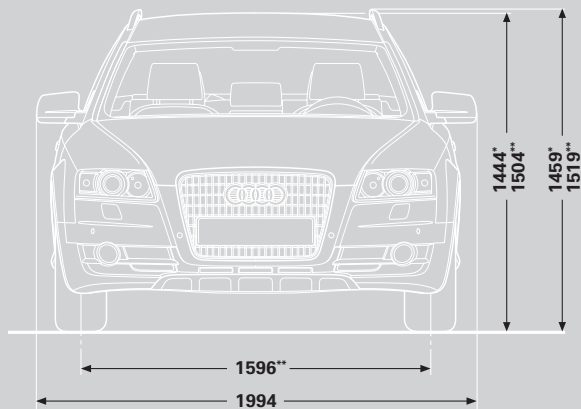

Dimensions in millimetres.

Dimensions measured with vehicle at unladen weight, ground clearance with vehicle carrying its maximum load

Luggage compartment volume 565 l, with rear seats folded and loaded to roof 1,660 l (measurement in accordance with VDA method with blocks of 200 x 100 x 50 mm edge length). Turning circle 11.9 m.

*dynamic mode.

**lift mode.