



Audi A8





*Discover the Audi A8.* We live in beautiful houses. We enjoy exquisite wines. We are inspired by cultural events. We travel to exotic countries. We have already experienced so much and seen almost everything there is to see. What is there left to surprise us? What still fills us with amazement? This catalogue gives you an insight into a very special car: the Audi A8. It gives impressive answers today to many of the questions that will be asked tomorrow.



You will be expecting a car in this class to be extremely comfortable. It will, however, come as somewhat of a surprise to find yourself looking forward to the first curve as soon as you get into a limousine of this kind. You are entitled to presume that we have built particularly powerful engines for the Audi A8. You will on the other hand be enthusiastic to experience the temperament and agility of the V6 and V8 engines. You have every right to assume that an Audi model will be packed with innovative technology.

You will, however, be astonished how easily this technology can be operated in the Audi A8. An elegant appearance is nothing unusual in the luxury class. The first impression becomes irresistible when a limousine has the attributes of a sports car at the same time. You are accustomed to getting up early every morning. You will on the other hand be startled to notice how much anticipation you feel in future when you do.

**Demonstration of superiority.** The Audi A8 diesel engine range is led by the 4.2 TDI quattro<sup>1</sup> with its impressive 240 kW. The V8 is one of the most powerful diesel engines available in the diesel limousines with this high capacity. It takes only 5.9 seconds to accelerate from 0 to 100 km/h as a result. The engine reaches its maximum torque of 650 Nm at only 1600 rpm and maintains this up to 3500 rpm. The engine's performance is boosted by two turbochargers with rotation speeds of up to 213000 rpm. Use of the latest common rail injection systems with piezo injectors guarantees high power combined with a reduction in fuel consumption and emission levels. The engine runs more smoothly and the acoustics are improved as well. The Audi A8 4.2 TDI quattro needs only 9.4 litres of fuel per 100 km.

**No doubt about it.** The Audi A8 3.0 TDI quattro<sup>1</sup> makes one thing clear right from the start too: sportiness and common sense are not mutually exclusive. The V6 with its direct injection system demonstrates its power in a thoroughly uncompromising way. There are never any doubts about the determination of its 171 kW. It responds eagerly with maximum torque of 450 Nm between 1400 and 3250 rpm. The latest generation of the common rail system is used in the 3.0 TDI too. The piezo injection technology increases the car's power and gives it an even smoother ride, while emissions are reduced at the same time.

Both engines are equipped with the 6-speed tiptronic as well. Like the Audi A8 4.2 TDI quattro, the 3.0 TDI quattro has a diesel particulate filter as standard and both meet the demands of the EU4 exhaust standard with no trouble at all.

<sup>1</sup> Fuel consumption and CO<sub>2</sub> emission figures can be found in the "Technical data" section starting on page 118.

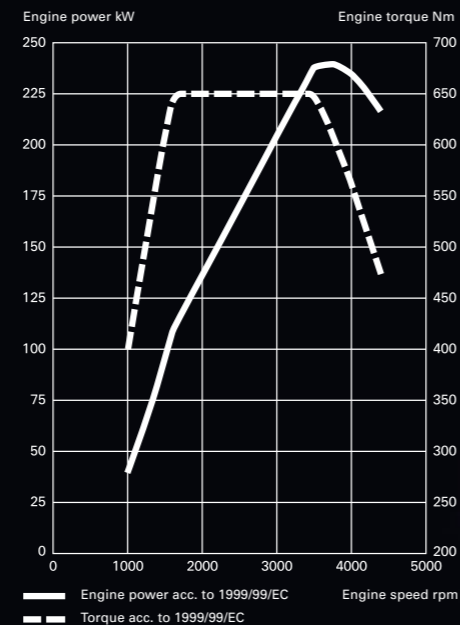

*The Audi A8. The only luxury limousine with quattro®.* The more powerful the engine, the more important the traction, i.e. direct application of the power to the road. So it goes without saying that we have combined the lively V8 engines and the pulling power of the V6 TDI® with permanent quattro® all-wheel drive as standard. quattro® is, however, more than just all-wheel drive. quattro® has symbolised the technical capabilities of the Audi marque for more than 25 years now and has already proved to be successful in numerous different models. With permanent quattro® all-wheel drive you enjoy the unique feeling of superiority, outstanding safety and dynamic performance every kilometre you travel.



The advantages of permanent quattro® all-wheel drive are felt not only on wet or snowy roads. quattro® gives the Audi A8 critical safety reserves on all road surfaces – in corners or on straights, up hills or along flat stretches. Because the driving forces of the engine are automatically distributed to all four wheels at all times with quattro® – in contrast to cars with single-axle drive. This improves traction and the power of the engine can be exploited more effectively.

If one of the wheels starts to spin, the driving force is automatically distributed to the axle with better grip. The effect: more dynamic driving, greater safety!

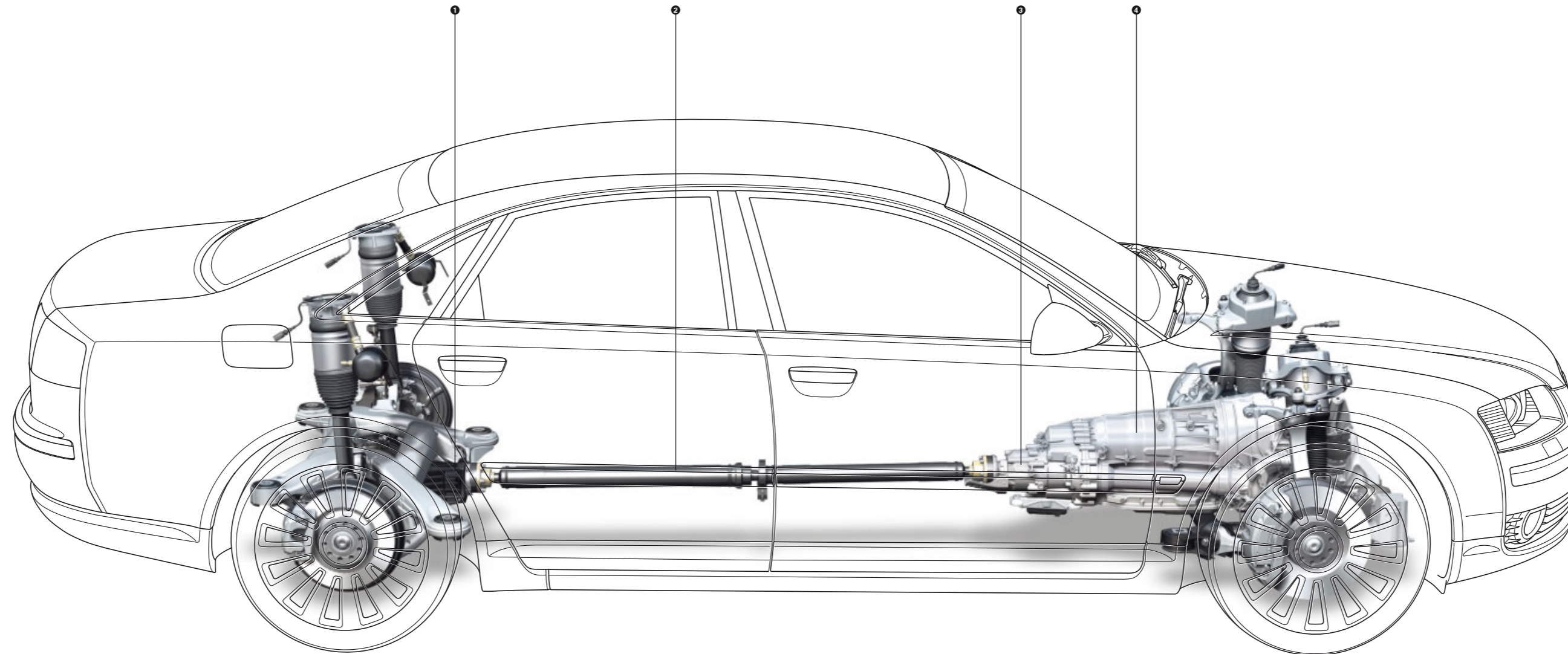

- ❶ Rear axle differential
- ❷ Cardan shaft
- ❸ Torsen centre differential
- ❹ 6-speed tiptronic with front axle differential

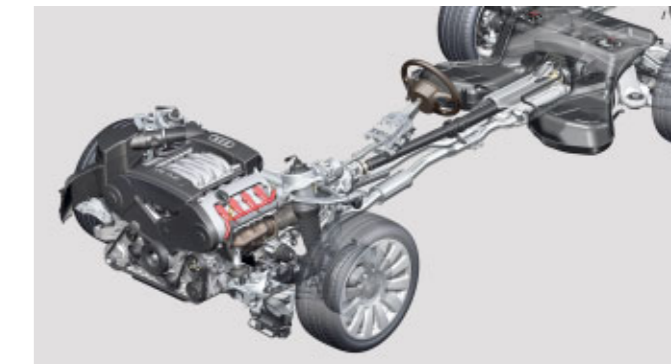

quattro® driveline – front axle.

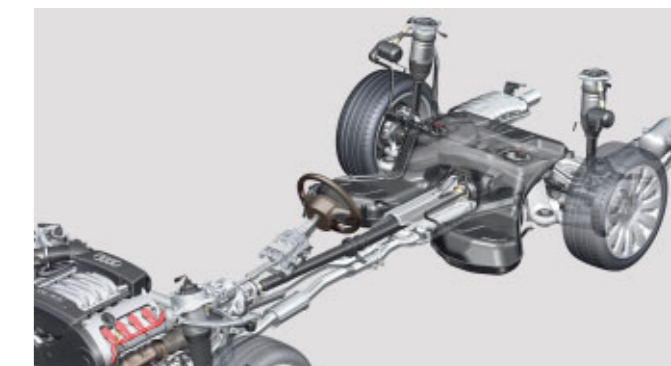

quattro® driveline – rear axle.



*A8 drivers demonstrate unerring style. Preferably their own.* You have furnished your home precisely the way you want it. Why should you not do the same with your Audi A8? With all the different options available to you, you have almost complete freedom to design the interior as you please: the elegant colour combinations do not exactly make it easy to choose. The A8 offers you even more freedom of choice than this, however. The inlay that graces the entire interior is divided up into two parts. It consists of a wide inlay made from the specific kind of wood you prefer. The narrower Micrometallic Platinum inlay is located directly beneath it.

Incidentally, the different types of wood available for the interior look just as impressive as they sound: Walnut Brown, Vavona wood Bernstein, fine grain birch wood grey and fine grain birch wood beige. We recommend our high-quality leather range for even more elegance. Here you have the choice between classically distinguished Valcona leather, superb natural leather, luxuriously elegant satin nappa leather or the Alcantara / leather combination, which gives your Audi A8 particular sports flair.

*Sit back and relax.* It is sheer pleasure to enjoy the unrestricted freedom of the A8 somewhat more extensively.

No problem at all here – our excellent seats meet even the most exacting of demands. There is a selection of luxurious seats such as the deluxe seat or the sports seat. The distinctive feature of the deluxe seat is softer upholstery. It is available with seat climate control and a massage function as an additional option. The sports seat has more highly contoured side sections which always guarantee good lateral support no matter how fast you corner. Both seats have electrical adjustment facilities at the top of the seat back as well. The passengers in the rear will find that their seats provide plenty of comfort and freedom too, however. Although the most exciting place in an Audi A8 is still the one behind the steering wheel.





**A8 L** *Higher. Faster. Further.* Performance requirements are increasing all the time. And people who have particularly demanding responsibilities face extremely high pressure too. We have developed the long-wheelbase version of the Audi A8 for them. A car that offers not just a perfect working environment but also maximum relaxation and, if you ever have the desire to take over the steering wheel yourself, a surprisingly enjoyable driving experience.



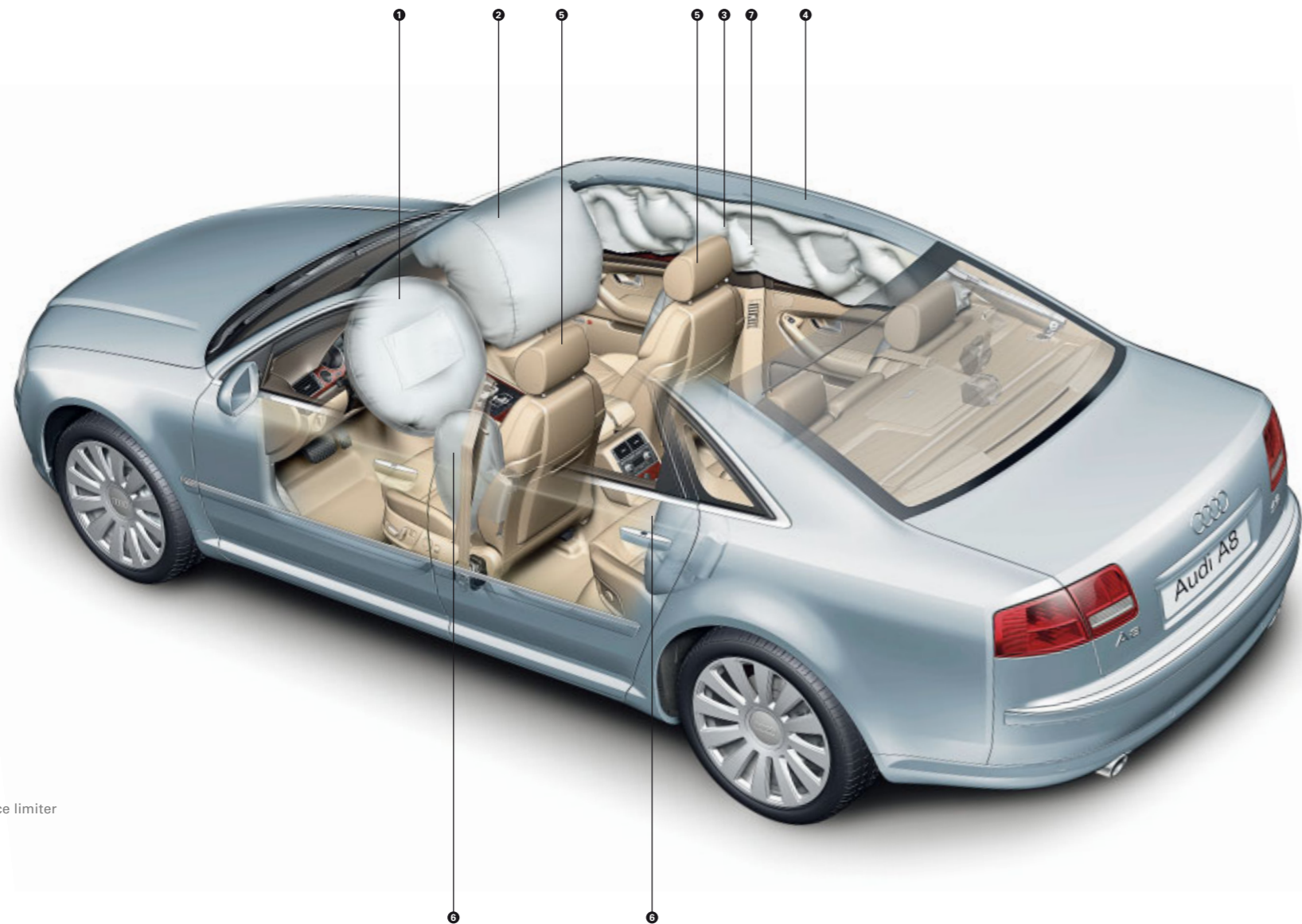

- ❶ Full-size airbag
- ❷ Full-size passenger airbag
- ❸ Belt system with tensioner and force limiter
- ❹ Audi Space Frame ASF®
- ❺ Audi backguard
- ❻ Side airbag
- ❼ Head-level airbag (sideguard)

**The advantage of computer crashes.** Car safety has been tested up to now in real collisions involving different prototypes. Our engineers adopted a new approach when developing the Audi A8: the entire car was reproduced as a virtual model and was subjected to every conceivable crash situation in a computer. This procedure produces even more informative results and makes it possible to carry out a considerably larger number of test series in a shorter time. The reliability of the passive safety systems of the Audi A8 was, for example, tested several thousand times in total, with further improvements being made all the time.

The safety of the Audi A8 was not checked in real crash tests as well until the virtual development work had been completed. The results were impressive and matched the computer simulations. This encouraging fact boosted our engineers' motivation and comforted them at the same time: the magnificent outcome of several years of development work was after all driven straight into a wall before their very eyes in the real-life crash tests.

**Every millisecond counts.** If the worst comes to the worst, everything has to go very quickly. The impact of a collision lasts only 100 milliseconds on average. This is how long it takes to bat an eyelid. However, the Audi A8 has even less time to identify the impact and to activate the appropri-

ate safety systems. We have therefore developed crash sensors. The system has several external sensors in the body, which react promptly when an accident occurs. They analyse the seriousness of the accident and initiate the relevant safety measures: the necessary airbags are inflated, belt tensioners are activated, the hazard warning lights are turned on, the central locking system is opened and the engine is switched off. And all of this is done faster than you can bat an eyelid!

**As safe as possible, as gentle as necessary.** It is, however, vital for an airbag to open not only quickly but also as gently as possible. This is true of the airbags for the driver and front-seat passenger as well as the head-level airbag system sideguard and the side airbags in the front and rear seat backs. What sounds incompatible turns out to be a convincing solution in our airbag system for the driver and front-seat passenger, which triggers in two stages. The airbags inflate either more or less according to the situation, so that the passengers face less strain while receiving the same protection.

The front seats are equipped with Audi backguard. If the car is hit from behind, the head restraints move forward mechanically and reduce the distance between the head and the head restraint. The particularly sensitive cervical verte-

brae are protected even more effectively as a result.

All of these safety features together with the rigid passenger compartment of the Audi Space Frame ASF® improve active and passive safety in the Audi A8.

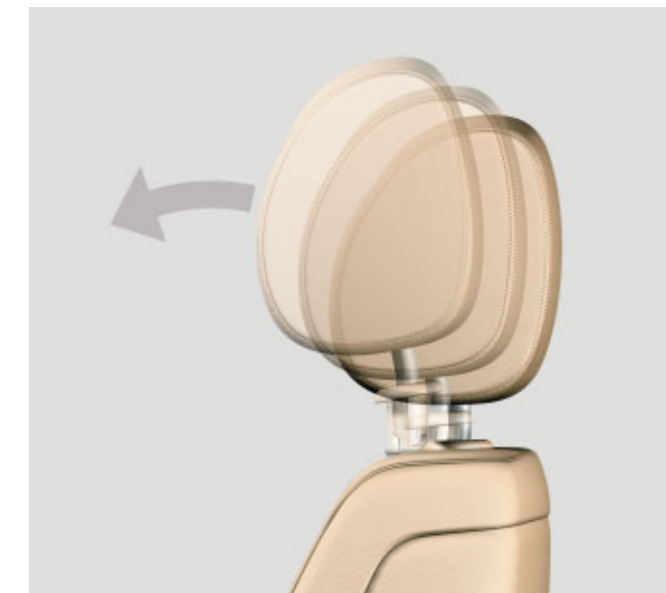

The front seats, which are fitted with Audi backguard as standard, minimise the distance between the head restraint and the head of the passenger when the car is hit from behind.



*What if your Audi A8 were as*

***u n i q u e***

*as you?*

*You have a distinct personality.* And you know how unique it makes you. The things around you are supposed to express your individuality. You will only rarely find your personal needs so perfectly satisfied as in your Audi A8. Because the extensive range of equipment available with it is designed specifically to match every single aspect of your personality, right down to the smallest detail. Which means that you can make the Audi A8 as unique as you yourself are.



**Audi exclusive refrigeration box with a bar compartment**  
Like the "Audi exclusive refrigeration box", with an additional bar compartment including two glasses with the Audi exclusive logo. Supplied by quattro GmbH



**Audi exclusive gear lever knob made of wood**  
In poplar saffron, fine grain maple copper, piano finish black, fine grain ash nougat, quilted maple gold, fine grain myrtle nutmeg or oak sepia. Supplied by quattro GmbH



**Cast aluminium wheels, 5-arm styling,**  
size 9 J x 19 with 255/40 R 19 tyres



**Forged aluminium wheels, 9-spoke styling,**  
high-gloss finish, one colour, size 9 J x 20 with 275/35 R 20 tyres, including the spare wheel that saves space



**Rear Seat Entertainment (RSE)**  
With two head restraint monitors with 6.5-inch LCD screens; DVD player with changer for 6 discs, two headphones and connections for external sources. Supplied by quattro GmbH

**Rear Seat Entertainment (RSE) plus**  
Same as RSE, with an additional connection to the car sound system and a TV connection. Supplied by quattro GmbH



**Individualised steering wheel rim with Audi exclusive wood and leather, in 3- or 4-spoke styling,**  
with full-size airbag; for operation of MMI®, radio and – if fitted – interactive voice system, telephone and Audi music interface, (with and without paddle switches for changing gear in manual mode). From quattro GmbH



**Cast aluminium wheels, 20-spoke styling,**  
in two parts, size 9 J x 19 with 255/40 R 19 tyres



**Forged aluminium wheels in 7-double-spoke styling,**  
polished, two-tone, size 9 J x 20 with 275/35 R 20 tyres, including space-saving spare wheel



**Audi exclusive charger**  
In the rear, for hands-free car phone headset. Supplied by quattro GmbH



**Cast aluminium wheels in 9-spoke styling,**  
size 8 J x 18 with 235/50 R 18 tyres



**Forged aluminium wheels, 9-spoke styling,**  
polished, two colours, size 9 J x 20 with 275/35 R 20 tyres, including the spare wheel that saves space



**Forged aluminium wheels, 7-double-spoke styling,**  
polished, two colours, size 9 J x 20 with 275/35 R 20 tyres, including the spare wheel that saves space



A8 in Night Blue, pearl effect.

Interior finishing: Valcona leather, amaretto brown, deep blue dashboard, Walnut Brown inlay, sports seats with memory function.



A8 in Silver, metallic.

Interior finishing: Valcona leather, black, black dashboard, fine grain birch wood grey inlay, deluxe seats with memory function.





**tiptronic, 6-speed**

For even more convenient and dynamic driving: the 6-speed automatic transmission with the Dynamic Shift Programme (DSP) allows you to choose between relaxed fully-automatic driving and active manual shifting, including an additional sports programme. (Not for the A8 3.2 FSI/A8 L 3.2 FSI)

**multitronic®**

Automatic transmission for comfortable, dynamic and satisfyingly smooth driving, including an additional sports programme; further choice between automatic transmission and 7-speed manual shifting. (For the A8 3.2 FSI/A8 L 3.2 FSI)

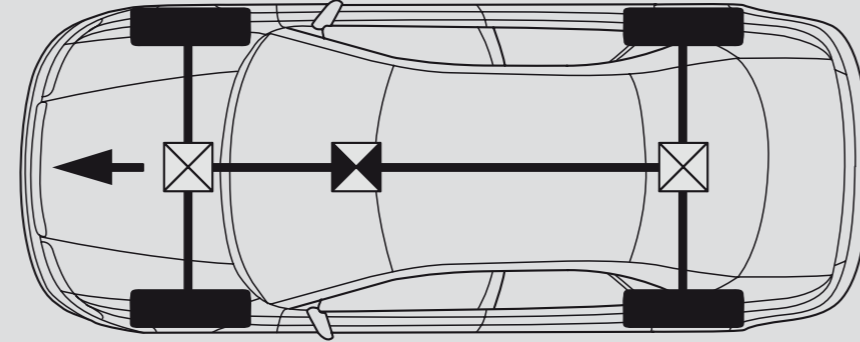

**quattro®, permanent all-wheel drive**

The infinitely variable distribution of the driving force and the automatic self-locking centre differential guarantee good traction

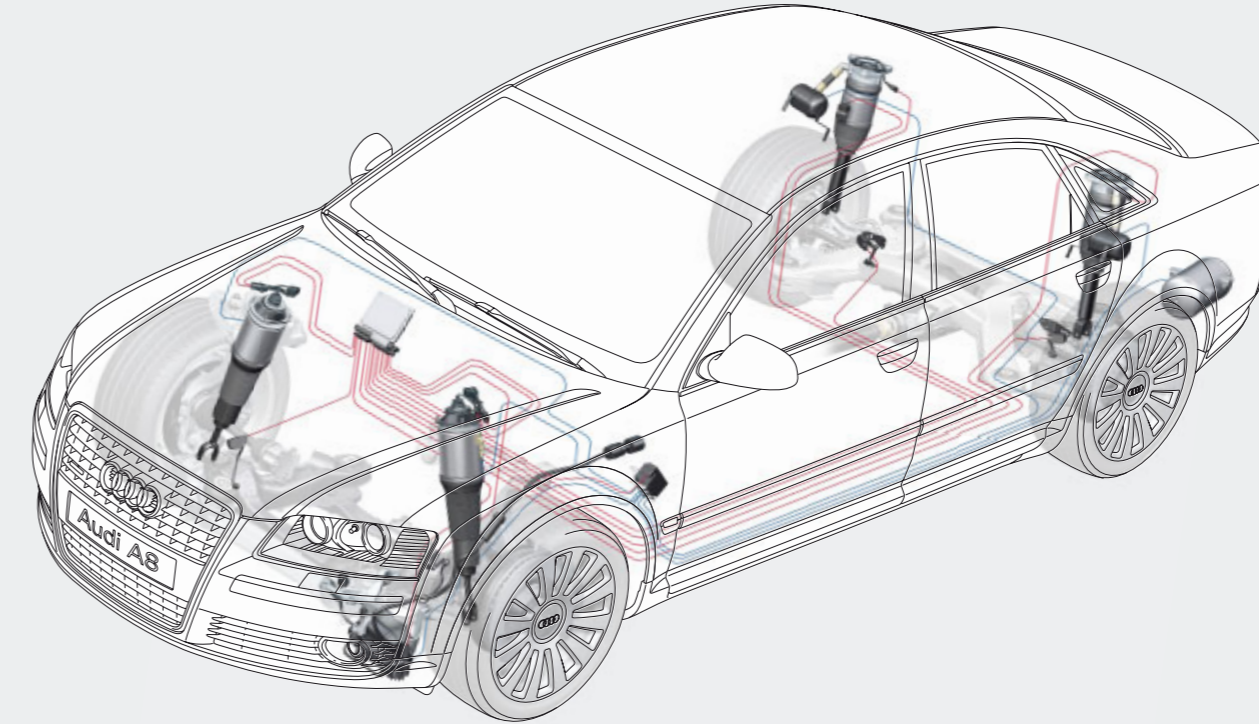

**adaptive air suspension**

Electronically controlled air suspension with an infinitely adaptive damping system on all four wheels, controls the car level and damping automatically; four modes (automatic, comfort, dynamic, lift), can be selected via the MMI®; including level control



**adaptive air suspension – sport**

Sports suspension based on the standard adaptive air suspension system; firmer damping, car level lowered by up to 20 mm according to the mode

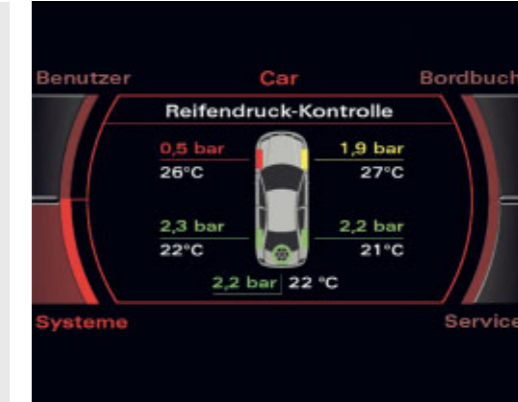

**Tyre pressure control system**

Monitors the air pressure level set for the wheels (including the spare wheel, if there is one) while the car is driving, including winter wheels supplied by the manufacturer; wheel air pressure and temperature levels can be displayed on the MMI

Model	A8 4.2 TDI quattro with standard diesel particulate filter	A8 L 4.2 TDI quattro with standard diesel particulate filter
<b>Engine type</b>	V8 turbocharged diesel engine with two VTG turbochargers, TDI® direct injection	V8 turbocharged diesel engine with two VTG turbochargers, TDI® direct injection
<b>Displacement, cc (valves per cylinder)</b>	4134 (4)	4134 (4)
<b>Max. output<sup>1</sup>, kW at rpm</b>	240/3750	240/3750
<b>Max. torque, Nm at rpm</b>	650/1600–3500	650/1600–3500
<b>Driveline/wheels</b>		
<b>Type</b>	Permanent quattro® all-wheel drive	Permanent quattro® all-wheel drive
<b>Transmission</b>	tiptronic	tiptronic
<b>Wheels</b>	8 J x 17 cast aluminium wheels	8 J x 17 cast aluminium wheels
<b>Tyres</b>	235/55 R 17	235/55 R 17
<b>Weights/capacities</b>		
<b>Unladen weight<sup>2</sup> in kg</b>	1945	1995
<b>Gross weight limit in kg</b>	2545	2595
<b>Roof load/nose weight limits in kg</b>	100/95	100/95
<b>Trailer weight limits<sup>3</sup> in kg</b>		
unbraked	750	750
braked, max. gradient 12%	2300	2300
braked, max. gradient 8%	2300	2300
<b>Approx. fuel tank capacity in l</b>	90	90
<b>Performance/consumption<sup>4</sup></b>		
<b>Top speed in km/h</b>	250 <sup>5</sup>	250 <sup>5</sup>
<b>Acceleration, 0–100 km/h in s</b>	5.9	6.1
<b>Fuel grade</b>	Diesel, EN 590	Diesel, EN 590
<b>Fuel consumption<sup>7</sup> in l/100 km</b>		
town	13.3	13.3
country	7.2	7.2
combined	9.4	9.4
<b>CO<sub>2</sub> emissions<sup>7</sup> in g/km</b>		
town	352	352
country	191	191
combined	249	249
<b>Exhaust standard</b>	EU4	EU4

**Notes**

- <sup>1</sup> This figure was determined by the specified measuring process (current version of RL 80/1269/EEC).
- <sup>2</sup> Unladen weight without driver (determined in accordance with the current version of RL 92/21/EEC). Optional extras may increase the unladen weight and the aerodynamic drag coefficient of the car, in which case the payload limit and top speed will be reduced accordingly.
- <sup>3</sup> The engine's power output always goes down at increasing altitudes. At 1000 metres above sea level and for every additional 1000 m, deduct 10% from the weight of the outfit (trailer weight limit + gross weight limit of the towing vehicle).
- <sup>4</sup> The fuel consumption and CO<sub>2</sub> emissions of a car depend not only on efficient use of the fuel by the car but also on driving style and other non-technical factors. CO<sub>2</sub> is the greenhouse gas that is mainly responsible for global warming.
- <sup>5</sup> Controlled top speed.
- <sup>6</sup> The use of Super (premium), unleaded fuel (95 RON) is recommended. If unavailable: regular grade, unleaded fuel (91 RON) can be used with a slight reduction in the car's performance.
- <sup>7</sup> The figures indicated were determined by the specified measuring process (current version of RL 80/1268/EEC). The figures do not relate to a single car and are not part of the offer made; their sole purpose is to facilitate comparison between the different car models.
- <sup>8</sup> The use of SuperPlus, unleaded fuel (98 RON) is recommended. If unavailable: Super (premium), unleaded fuel (95 RON) can be used with a slight reduction in the car's performance.

**Important note**

Inspections are due as indicated by the service display in the car.

**Dimensions – Audi A8**

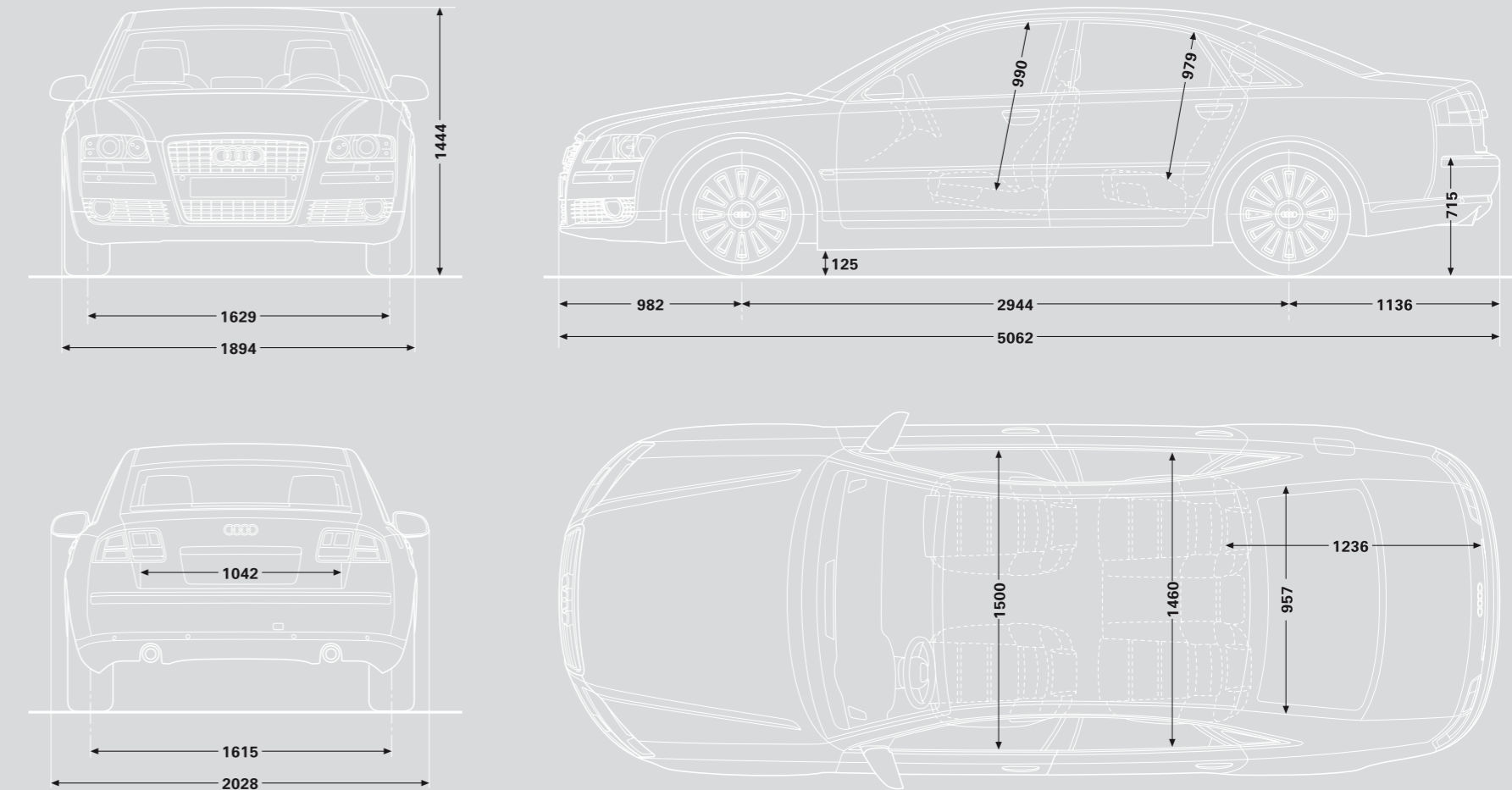

**Figures in millimetres.**

The dimensions indicated relate to the unladen car; the road clearance figures apply to a car with the maximum load. Luggage capacity in l: 500 (measured according to the VDA test method, using 200 x 100 x 50 mm blocks). Turning circle about 12.1 m.