



Audi

Audi Q7



**As far as this is concerned,
nothing's changed.**

Harald Demuth covered a distance of 78 m in his Audi 100 quattro® in 1986. Just a short distance. But long enough to engrain the fascination for the quattro® drive into the consciousness of an entire generation. Because these 78 m were not exactly easy going. The German rally master of 1982 and 1984 not only had to command the 37-degree incline and a snow-covered ground, but also himself. Never before had a person climbed a snowed-over ski jump in a car. Harald Demuth kept cool. And the Audi quattro® too. Powerfully and impressively it mastered the 80 percent incline of the jump in Kaipola, Finland. A few seconds of driving, which were beamed all around the world and made not only quattro® but also the fundamental Audi principle famous to everybody: Vorsprung durch Technik.

Once again, with the Audi Q7, Audi succeeds in astonishing the world and demonstrating exactly what Vorsprung durch Technik means. The Audi Q7 takes the successful quattro® drive idea forwards and into a new dimension. With a sporty design and powerful engines it's showing off its original roots: driving enjoyment, power and dynamism. It sets new benchmarks with exceptional comfort and a generous amount of space. A car, which confidently takes you to any destination. Which is at home on any road. And also where there aren't any.







Whether on winding mountain roads or flat freeways, the Audi Q7 is distinguished by its overwhelming urge to push forward. The 6-stage automatic transmission with tiptronic assists you in bringing as much power to the road as possible, all the time. The transmission is designed especially for high-torque engines and directly assists you when driving in tricky terrains by converting engine power quickly and effectively into driving power. Not only its high degree of efficiency but also the reduced weight of the automatic transmission ensure more dynamics. Because of the transmission's smaller size it is very light. Another reason for the low power-to-weight ratio of the Audi Q7.

Where there's an Audi Q7 there's a way. With the optionally available adaptive air suspension it gives you even more independence. This directly intervenes in damping the individual wheels. By eliminating permanent car body movements and automatically reducing rolling or pitching motions when cornering, braking or starting up it ensures a comfortable driving feeling and more grip.

Adaptive air suspension gives the Audi Q7 the variable ground clearance, which defines an SUV. At the same time, it combines the sporty driving character of a Coupé with the excellent suspension comfort of a saloon, by enabling damping and vehicle height to be variably regulated. The damper adjustment and height, and with this the handling, can be individually controlled in five stages. With just one move of the hand you can switch between automatic, comfort, dynamic, off-road and lift modes using the MMI.

The optional comfort and dynamic settings ensure excellent driving comfort or improved handling. In all stages the adaptive air suspension independently lowers the body appropriately for the speed and adjusts the dampers accordingly. Lowering the vehicle height at greater speeds creates a lower centre of gravity, noticeably increasing the driving stability. The off-road mode raises the trims by 25 mm, allowing off-road driving at up to 100 km/h. On impracticable terrain or when slowly driving over large obstacles the lift setting assists you by raising the trims by 60 mm. Alongside these diverse characteristics, adaptive air suspension also works as classic height regulation. It keeps the trims in a constant position, independent of load.





See and be seen – that isn't just a question of design, but of the right lighting system especially. On the Audi Q7, the optionally available Xenon Plus headlights with a light colour resembling daylight ensure very good visibility with a low dazzling effect. The brightly illuminating headlights emphasise the powerful pointed shape of the front and exude self-confidence, not just at night time.

You can assess what's going on around you with a confidence as great as that exuded by the Audi Q7's appearance. Its optionally available dynamic cornering light, adaptive light, not only illuminates straight ahead, but also swivels in the direction of driving and according to the steering angle, speed and vehicle inclination. In this way, bends are thus illuminated better when steering into them. This helps you to recognise hazards and other drivers in good time. This supports an anticipatory driving style.



Multifunctionality doesn't have to be complicated. The Audi Multi Media Interface MMI takes care of this. Just one move of the hand and the central control system in the Audi Q7 gives you rapid access to important vehicle information and functions: depending on equipment, radio, CD, Audi music interface or TV, your telephone as well as traffic announcements and the navigation system. It is controlled via the MMI terminal with function keys and the central control button. The MMI display is located in the centre of the dashboard and shows the requested information.

The Audi Q7 is fitted with MMI basic as standard, which includes radio and CD functions as well as basic vehicle settings. The optionally available MMI basic plus extends the basic equipment to include the option of saving radio traffic announcements and a DSP sound system with eleven loud speakers. The MMI top version offers a colour 7-inch display and an MP3-capable CD changer. If required, it is also available with a DVD navigation system, amongst other things.

The Audi music interface is provided to run portable MP3 players such as the iPod (generation 4 and higher). This interface allows you to control the player's function both via the MMI and using the multi-function steering wheel. Please contact your Audi partner for information on the compatibility of MP3 players produced by other manufacturers.

The Audi Q7 gives everything it has to make its operation as straightforward as possible for you. This begins as soon as you get in. With the optionally available advanced key the Audi Q7 automatically recognises you and unlocks itself as soon as you activate the door or tailgate. You can also start and stop the engine just as conveniently without having to insert the key in the ignition: a single press of the start/stop button in the centre console is all it takes.

The Audi Q7 will even help you with parking. The Audi parking system warns you acoustically when it recognises obstacles behind the vehicle. The optionally available Audi parking system plus also keeps an eye on the area in front of the Audi Q7 and warns you by means of both an acoustic signal and visually via the MMI. In the top version Audi parking system advanced, the Audi Q7 is additionally equipped with a reversing camera. The display appears on the MMI screen. Guidelines are incorporated into the camera image; parking and hitching trailers is easier than it has ever been.



Seats with seat covers in black/magnolia two-tone look in Fine Nappa leather.



Steering wheel rim with coloured seam.



Tamo ash dark brown decorative inlay.



Gear lever gaiter with coloured seam.

Audi exclusive line

Black interior (including black attachments)

Headlining black cloth

Two-tone seat covers (seat side bolsters black/seat centre panel optionally in white, silver or Cognac) in Fine Nappa Leather (standard seats); optional: sports seats

Door panel inserts (corresponding to seat centre panel)

Audi exclusive sill trims

Brushed aluminium matt decorative inlay; optional: Tamo ash dark brown

Floor mats with coloured piping (corresponding to seat centre panel)

Multi-functional sports leather steering wheel in 4-spoke styling, with coloured seam (corresponding to seat centre panel), optional: multi-functional sports leather steering wheel in 3-spoke design with additional switches with coloured seam (corresponding to seat centre panel)

Side bolsters, head restraints, steering wheel trim and gear lever gaiter with coloured seam (corresponding to seat centre panel)



Audi Q7 in Silver Metallic with contrasting paint in Platinum Grey Matt; with polished, cast aluminium wheels in 5 double-spoke styling, two-colour, size 9 J x 20 with 275/45 R 20 tyres.
"Sport" equipment design package: Sports seats in black Alcantara/leather, decorative inlays in Aluminium Marlin Silver, black dashboard, multi-function 3-spoke sports leather steering wheel.



Audi Q7 in Lava Grey pearl effect with contrasting paint in Platinum Grey Matt; with cast aluminium wheels in 7-arm structure styling, size 8.5 J x 19 with 265/50 R 19 tyres.
"Leather plus" equipment design package: Standard seats in Verano Cardamom Beige leather, Tamo Dark Brown decorative inlays, black/Borneo Green dashboard, multi-function 3-spoke sports leather steering wheel.





Multi-function sports leather steering wheel
in 3-spoke styling, full-size airbag and perforated leather, to operate the MMI system, radio, speech dialogue system and telephone or mobile phone (if also fitted); optionally available with gearshift paddle switches behind the steering wheel for gear changing

Safety steering column
increases the safety potential of the seat belts and airbags

Electric steering wheel adjustment
adjustable in height and reach, with automatic entry and exit function – so that you can comfortably set your desired driving position



Sports leather steering wheel
in 3-spoke styling, full-size airbag and perforated leather; with gearshift paddle switches behind the steering wheel for gear changing



Multi-function leather steering wheel
in 4-spoke styling and full-size airbag, to operate the MMI system, radio, speech dialogue system and telephone or mobile phone (if also fitted); optionally heated (can be switched off)



Leather steering wheel
in 4-spoke styling and full-size airbag, manually adjustable for height and reach



3rd row of seats
2 seats in the back with folding headrests and 2 additional ISOFIX child seat mountings, can be split and folded flat to provide a flat loading floor, for persons up to 1.60 m in height, with easy entry and longitudinal adjustment for the 2nd row of seats. The car then provides space for up to 7 persons. Optionally with two comfort seats in the 2nd row of seats



Automatic comfort air conditioning

with sunlight-dependent control, separate temperature and air distribution for driver's and front passenger's side, indirect ventilation, air conditioning of the rear via air vents in the B-pillars and rear centre console, automatic air recirculation control using an air quality sensor, rapid defrost button, combined pollutant and pollen filter, key recognition

Manual air conditioning system

cools or heats the vehicle interior, air vents in the dashboard, the rear centre console, footwell vents front & rear and defroster vents for windscreen and side windows, with manual air recirculation mode, combined pollutant and pollen filter, infinitely-variable fan and manual air distribution. (Not available in conjunction with parking heater/ventilation)

Parking heater/ventilation

with timer and separate radio remote control with function feedback; provides pleasant ambient conditions in your vehicle, even when you're not moving; the heating warms up the interior and keeps the windows free from ice, the parking ventilation supplies fresh air and reduces the interior temperature

Instrument cluster

with adjustable lighting; dials for rev counter, electronic speedometer, coolant temperature display and fuel gauge; time and date display, mileage and trip odometer, warning and telltale lamps, maintenance interval display (in connection with driver information system, display of radio frequency, outside temperature and fuel tank range)



Four-zone automatic comfort air conditioning

in addition to the automatic comfort air conditioning features, separate temperature adjustment and air distribution for the left and right hand sides at the rear, air vents in the C-pillar, air conditioning controls for the rear in the rear centre console; rear functions can also be adjusted from the front air conditioning controls, including additional air conditioning unit in the luggage compartment side panel



MMI basic

integrated control concept, includes MMI terminal (control unit) and MMI display (monochrome 6.5 inch screen in the dashboard), extra display in combination instrument panel, basic personalisation of vehicle functions, integrated radio; single CD player in the dashboard (single CD player under the centre armrest in conjunction with optional CD changer)

MMI basic plus

integrated control concept, includes MMI terminal and MMI display (monochrome 6.5 inch screen) with upgraded radio TA memory (automatically saves traffic announcements); DSP sound system (7-channel amplifier, 11 loudspeakers with exceptional sound, 180 watts total output)

MMI

integrated control concept, includes MMI terminal and MMI display (high-definition 7 inch colour screen), upgraded radio with twin-tuner (searches for alternative frequencies for the same station simultaneously); DSP sound system and 6-disc CD changer (MP3 and WMA-capable) replace single CD player. Music files with digital rights management (DRM) cannot be played

Driver information system

provides you with information from the trip computer via a display, auto-check control system, clock and display range of MMI system



Driver information system

with colour display, high-resolution, good clarity thanks to colour display, navigation system can be displayed in 3D

Audi Q7 5-seater

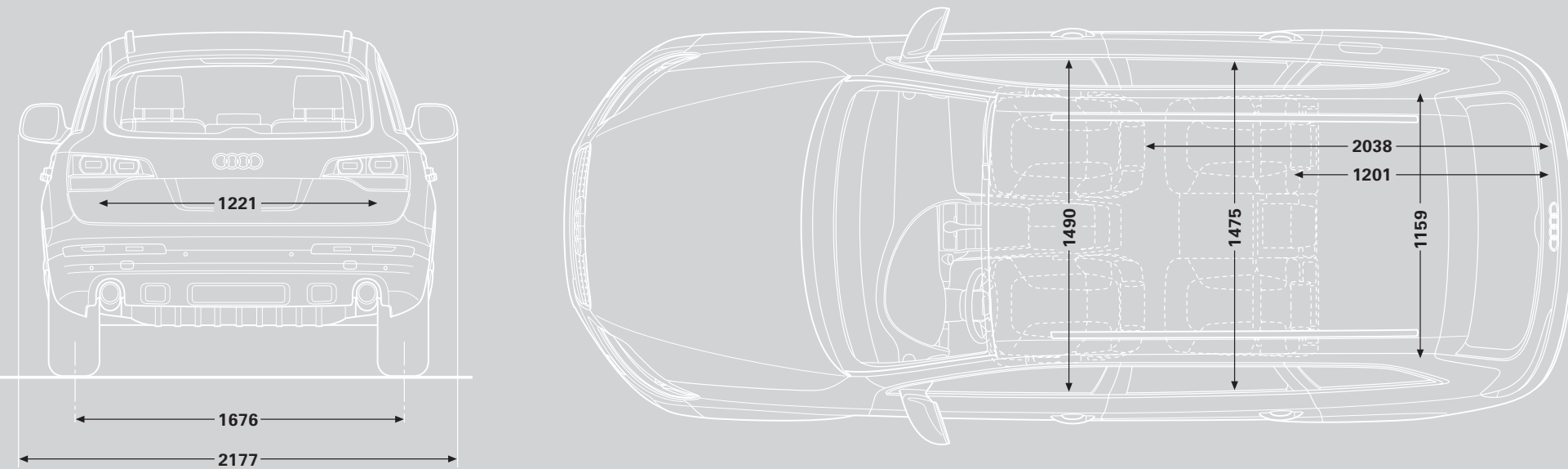
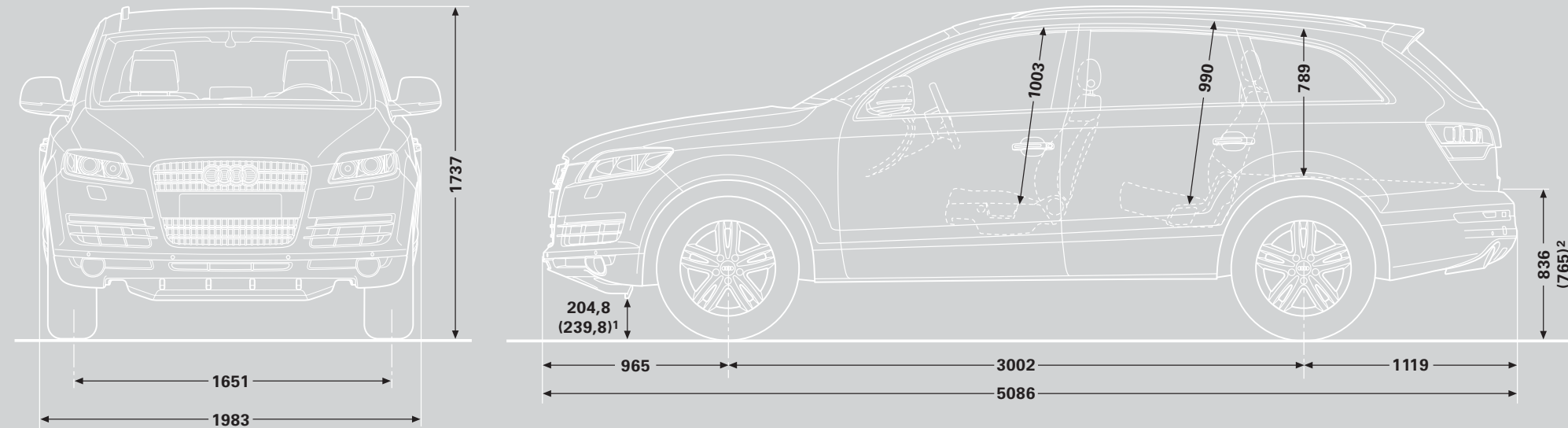

Dimensions in millimetres.

Dimensions were measured with vehicle at unladen weight, ground clearance measured with vehicle carrying its maximum load
Luggage load area in l: 775/2035 (Measured by the VDA standard test method using 200 x 100 x 50 mm blocks.
Second value is with the rear seat folded down and the vehicle loaded up to roof height). Turning circle approx 12 m.

¹ With optional air suspension, in lift mode.

² With optional air suspension, in loading level.

Audi Q7 7-seater

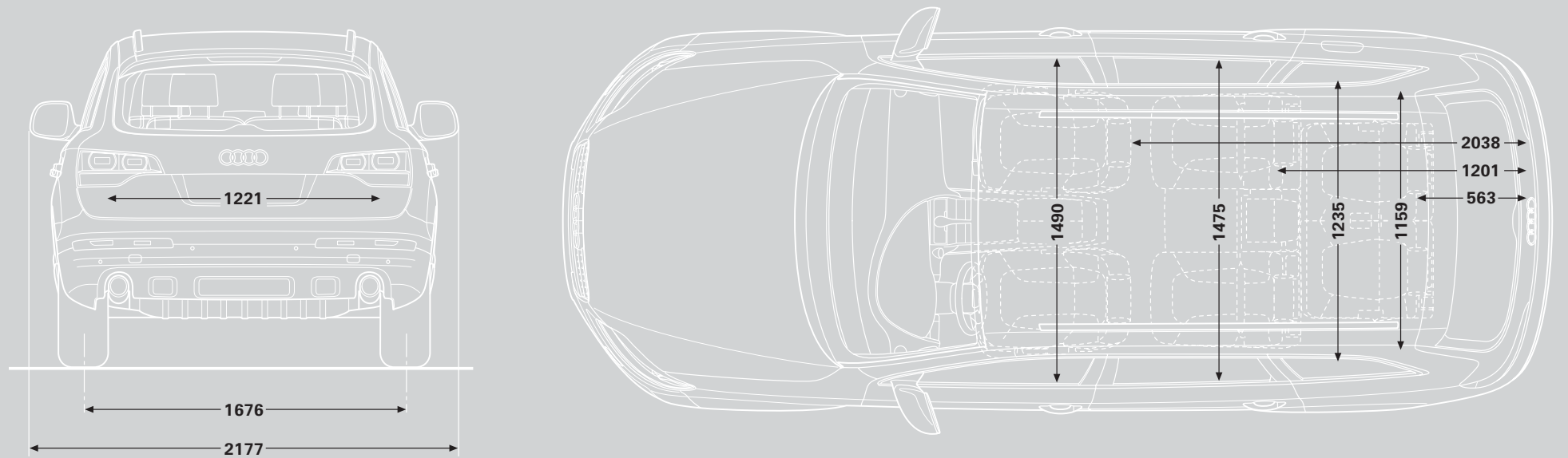
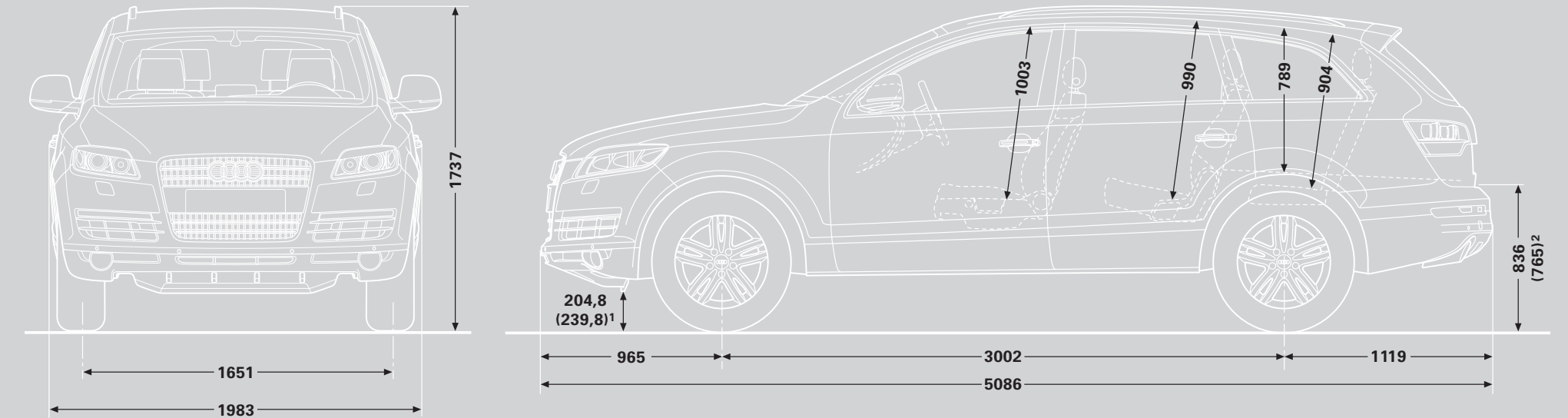

Dimensions in millimetres.

Dimensions were measured with vehicle at unladen weight, ground clearance measured with vehicle carrying its maximum load
Luggage load area in l: 775/2035 (Measured by the VDA standard test method using 200 x 100 x 50 mm blocks.
Second value is with the rear seat folded down and the vehicle loaded up to roof height). Turning circle approx 12 m.

¹ With optional air suspension, in lift mode.

² With optional air suspension, in loading level.



You've only just set off
and already you've arrived:
dynamics that thrill.