



Audi

TT



Pure design.



The Audi TT is a design icon. And design icons are untouchable. But we've done it anyway – we've changed the TT. We've re-defined it. Reinterpreted it. To make the icon even more resolute in its second generation. Form that flows from function – that's the new Audi TT Coupé.



TT lines. Pure character since the first design study. The roof line extends like a cupola over the low-slung cabin. And opens out into the powerful shoulder line. As well as the flared wheelarches, the twin tailpipe, the wide track. A clear message: The new Audi TT Coupé is a sports car.



The new Audi TT Coupé – completely captivating inside and out. Inlays in Aluminium Laser give a sporty accent if desired. Sports leather steering wheel with flattened base, ergonomically-formed sports seats with integrated head restraints. Pure sporting elegance.



S line – Redefining sportiness.

Experience the TT Coupé all over again. The S line exterior package and S line sports package emphasise the dynamic presence of the TT Coupé and make the car even more fun to drive. This is assured by the sports seats in an attractive combination of cloth and leather and a luxurious sports leather steering wheel with silver-coloured stitching detail. On the outside, the TT Coupé displays its athletic side, with sporty, powerful bumpers. A range of exclusive wheels is also available for the TT Coupé. Relish the thrilling overall impression your car will make. Give your TT Coupé a whole new sportier look.

adaptive light

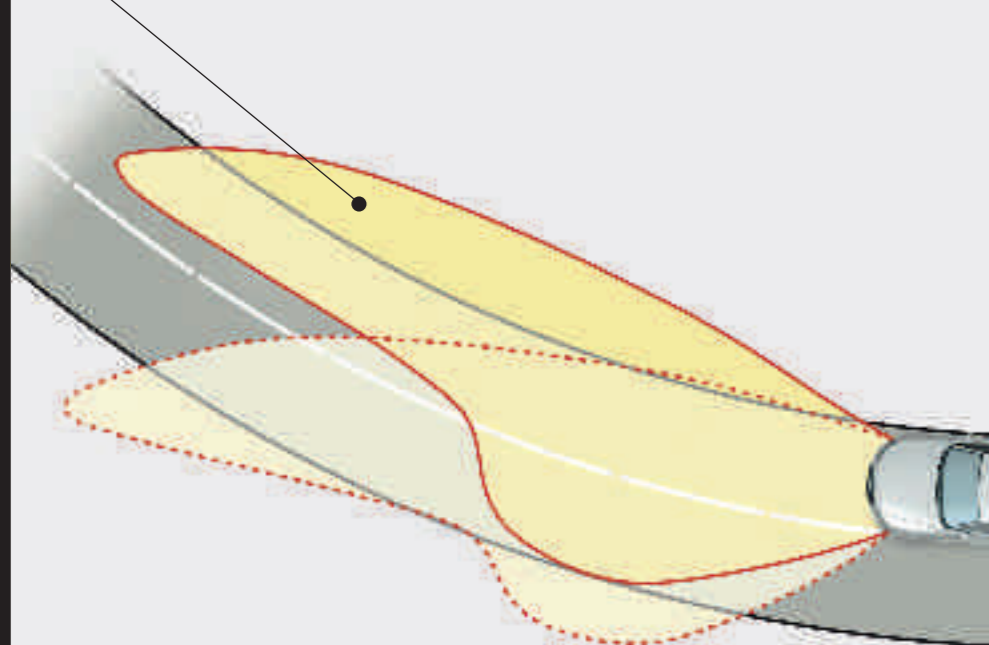
**adaptive light**

available in conjunction with Xenon plus; when cornering, dynamic light is provided by pivoting headlights for better cornering visibility

Gas struts

for engine compartment and tailgate

Exhaust tailpipes

double tailpipe on left (2.0 TFSI)
twin pipes, left and right (3.2 quattro)

tire mobility system

12 V compressor and tyre sealant in luggage compartment, maximum speed 80 km/h
(not available in conjunction with wheels with run-flat properties)

Anti-theft wheel bolts

can only be loosened with the supplied adapter

Vehicle jack**17" and 18" wheels**

with optional run-flat properties

**Dark-grey painted brake callipers****Wheels/tyres**

Cast aluminium wheels
in 10-spoke star styling,
size 7.5 J x 16 with 225/55 R 16 tyres



Cast aluminium wheels
in 5-arm trapezoidal styling,
size 8 J x 17 with 225/50 R 17 tyres



Cast aluminium wheels
in 10-spoke styling,
size 9 J x 18 with 245/40 R 18 tyres



Cast aluminium winter wheels
in 10-spoke star styling,
size 7 J x 16 with 225/55 R 16 H tyres,
permitted top speed 210 km/h



Lightweight forged aluminium wheels
in 7-Y-spoke styling,
size 8.5 J x 17 with 245/45 R 17 tyres



Aluminium-Gussräder
in 10-spoke styling,
size 9 J x 18 with 245/40 R 18 tyres,
polished, two-tone



Lightweight forged aluminium winter wheels
in 7-Y-spoke styling,
size 7 J x 17 with 225/50 R 17 H tyres,
permitted top speed 210 km/h



Cast aluminium wheels in 7-arm styling,
size 9 J x 18 with 245/40 R 18 tyres



Cast aluminium winter wheels
in 10-spoke styling,
size 9 J x 18 with 245/40 R 18 V tyres,
permitted top speed 240 km/h



Audi TT Coupé in Petrol Blue pearl effect, with cast aluminium wheels in 10-spoke styling, polished, two-tone. Sports seats in stone blue Athlete leather, enhanced colour leather package, enhanced aluminium look in interior.



Audi TT Coupé in Silver metallic, with cast aluminium wheels in 7-arm styling. Sports seats in black Alcantara/Leather, enhanced leather package, enhanced aluminium look in interior.



**Alcantara/Leather combination**

head restraints, seat and side bolsters in leather; seat centre panels and door trim in Alcantara

Valetta leather

head restraints, seat and side bolsters, seat centre panels in Valetta leather

Fine Nappa leather

head restraints, seat and side bolsters, seat centre panels in Fine Nappa leather

Leather package

handbrake grip, additional centre console armrest, door closing handles in black leather. (Can only be ordered in conjunction with Leather or Alcantara/Leather trim)

Sports seats at front

with pronounced side bolsters for better support while cornering; manual front/back, head restraint and seat back angle adjustment; seat height adjustment for both driver and front passenger seats

Lumbar support

electric four-way adjustment for the front seats

Electric seat adjustment for the front seats

including lumbar support, electric front/back, seat height, seat and backrest angle adjustment

Seat heaters for the front seats

with three settings, also heat side bolsters

Athlete leather trim

seat and side bolsters, head restraints, door trim in stone blue Fine Nappa leather; steering wheel rim, gear lever knob and gear lever gaiter in black leather with colour stitch detail; also includes the features from the leather package in the following styles: door closing handles in stone blue Fine Nappa leather; handbrake grip, additional centre console armrest in black Fine Nappa leather with colour stitch detail

Seat covers with special TT seam design

in Tetris cloth

**Enhanced colour leather package**

handbrake grip, additional centre console armrest, instrument panel cover in black leather; centre console trim, door armrests, door closing handles in coloured leather (to match colour of seat covers). (Can only be ordered in conjunction with Leather or Alcantara/Leather trim)

Enhanced leather package

handbrake grip, additional centre console armrest, door closing handles, instrument panel cover, centre console trim, door armrests in black leather. (Can only be ordered in conjunction with Leather or Alcantara/Leather trim).

**Rear seat backrest**

50:50 split and folding

Rear seats

two seats in rear, approved for persons up to 1.50 m tall or children up to 12 years old and 1.25 m tall in child seats

ISOFIX child seat mounting

for front passenger seat, mounting for attaching child seats in accordance with ISO standard

ISOFIX child seat mounting and rear bench seat with Group III child seat approval

ISOFIX child seat mounting for the two rear seats and the front passenger seat, mounting for attaching child seats in accordance with ISO standard; rear bench seat with Group III child seat approval (in accordance with ECE R44). For information on when this feature will be available, please contact your Audi partner.

Power steering

electromechanical, speed-sensitive power steering, with active reset assistance, automatic straight-line running correction, e.g. in side winds or roads with adverse camber; energy-saving operation, damping of road-induced interference

Traction control (ASR)

reduces spin at the drive wheels by reducing engine power – providing better traction and stability on the road surface

Safety steering column

adds to the protection potential offered by the seat belt and airbag; with mechanical inclination and axial adjustment

Sports suspension

with dynamically tuned springs and shock absorbers

S line sports suspension from quattro GmbH

with more dynamic chassis tuning and body lowered by 10 mm

Tyre pressure monitoring system

during the journey monitors the tyre pressures set and transferred to the system by the driver; should one or more of the tyres lose air, the tyre pressure monitor uses the difference in the rotational speed and the natural frequency of the wheels to calculate the air loss and gives the driver a visual and audible warning; the position of the affected wheel is shown in the driver information system display. The system is not intended as an alternative to carrying out regular tyre pressure checks.

Anti-theft alarm system

includes interior monitoring and tow-away protection provided by an angle of inclination sensor; can be switched off; horn works independently of vehicle electrical system; monitors engine compartment, luggage compartment, doors and interior

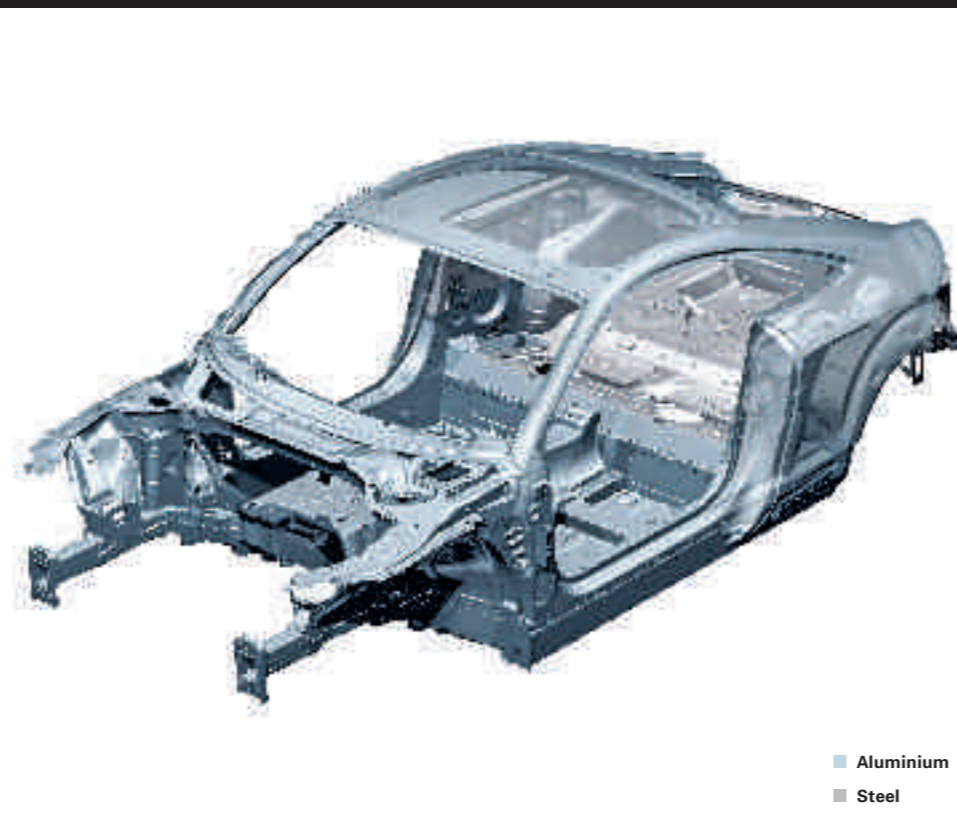
**Body****Audi Space Frame ASF® construction**

innovative combination of aluminium and steel, offering a high-level of stiffness for more dynamic handling, driving stability and enhanced safety

**Audi magnetic ride**

adaptive damper system; chassis setting (normal/sport mode) can be individually selected from button on front centre console; improves ride comfort and handling by regulating the damping forces according to the prevailing driving conditions

**S tronic**

6-speed twin-clutch transmission, electrohydraulically actuated

6-speed manual transmission

synchromesh on all gears

Gear lever knob

with leather gear lever gaiter and aluminium trim ring

Short-throw gear change

reduced shift travel; short, sporty gear lever. For information on when this feature will be available, please contact your Audi partner.

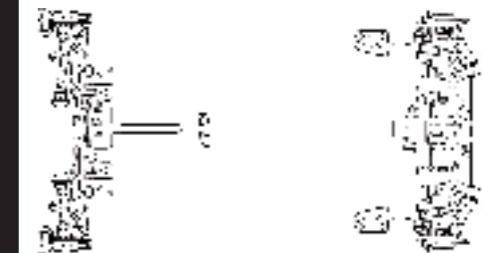
**quattro®**

permanent all-wheel drive for more traction and increased safety (3.2 quattro)

Model	TT 2.0 TFSI	TT 2.0 TFSI S tronic	TT 3.2 quattro	TT 3.2 quattro S tronic
Engine type	In-line 4-cylinder petrol engine with petrol direct injection and exhaust gas turbocharging	In-line, 4-cylinder petrol engine with petrol direct injection and exhaust gas turbocharging	V6 petrol engine with intake manifold injection	V6 petrol engine with intake manifold injection
Displacement, cc (valves per cylinder)	1984 (4)	1984 (4)	3189 (4)	3189 (4)
Max. output¹, kW, at rpm	147/5100–6000	147/5100–6000	184/6300	184/6300
Max. torque, Nm, at rpm	280/1800–5000	280/1800–5000	320/2500–3000	320/2500–3000
Transmission/wheels				
Type of drive	Front-wheel drive	Front-wheel drive	quattro® permanent all-wheel drive	quattro® permanent all-wheel drive
Transmission type	6-speed manual transmission, synchromesh on all gears	6-speed S tronic, electrohydraulically actuated	6-speed manual transmission, synchromesh on all gears	6-speed S tronic, electrohydraulically actuated
Wheels	Cast aluminium wheels, 7.5 J x 16	Cast aluminium wheels, 7.5 J x 16	Lightweight forged aluminium wheels, 8.5 J x 17	Lightweight forged aluminium wheels, 8.5 J x 17
Tyres	225/55 R 16	225/55 R 16	245/45 R 17	245/45 R 17

Weights/capacities

Unladen weight² in kg	1260	1260	1410	1430
Gross vehicle weight in kg	1660	1660	1810	1830
Roof load in kg	75	75	75	75
Fuel tank capacity in l	55	55	60	60

Performance/consumption³

Top speed in km/h	240	240	250 (regulated)	250 (regulated)
Acceleration 0–100 km/h in s	6.6	6.4	5.9	5.7
Fuel grade	Super unleaded 98 RON ⁴	SuperPlus unleaded 98 RON ⁴	SuperPlus unleaded 98 ROZ ⁴	SuperPlus unleaded 98 ROZ ⁴
Fuel consumption⁵ in l/100 km	urban	10.7	10.6	14.7
	extra-urban	6.0	6.0	7.8
	combined	7.7	7.7	10.3
CO₂ emission⁵ in g/km	urban	255	252	352
	extra-urban	143	143	187
	combined	183	183	247
Emissions standard	EU4	EU4	EU4	EU4

See page 81 for notes ¹ to ⁵.**Notes**

- ¹ The figure given has been calculated in accordance with the specified measuring procedure (current version of Directive 80/1269/EEC).
- ² Vehicle unladen weight without driver (calculated in accordance with the current version of Directive 92/21/EEC). Optional equipment may increase the car's unladen weight and drag coefficient, whereby the possible payload limit and top speed will be reduced accordingly.
- ³ The fuel consumption and CO₂ emissions of a vehicle depend not only on the efficient utilisation of the fuel by the vehicle, but also on driving behaviour and other non-technical factors. CO₂ is the greenhouse gas that is primarily responsible for global warming.
- ⁴ If this is not available, use Super unleaded (95 RON); power output will be slightly reduced.
- ⁵ The figures given have been calculated in accordance with the specified measuring procedures (current version of Directive 80/1268/EEC). The figures do not refer to one individual vehicle and do not form part of any offer, but rather should be used purely for purposes of comparison between the different vehicle models.

Important note

Inspections are due as shown on the service display.

Audi TT Coupé

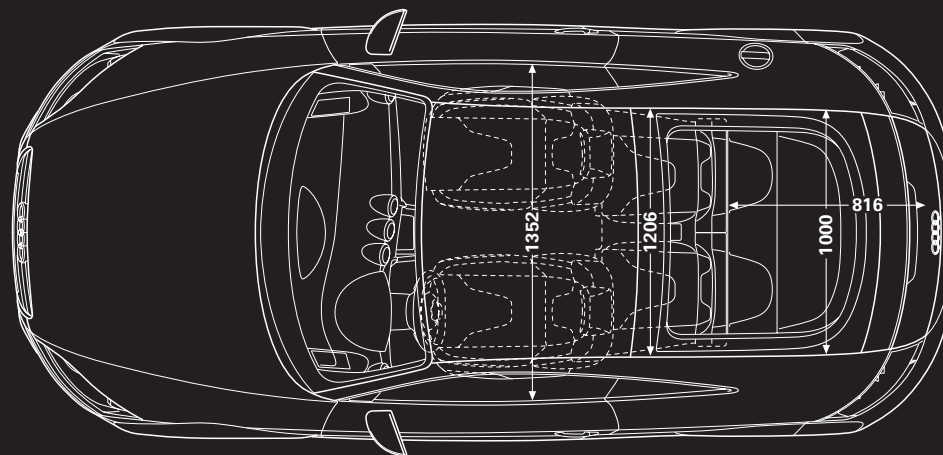
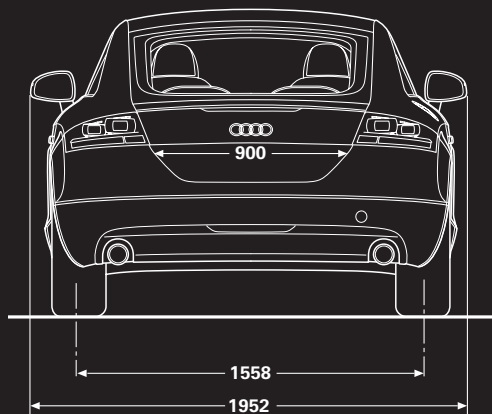
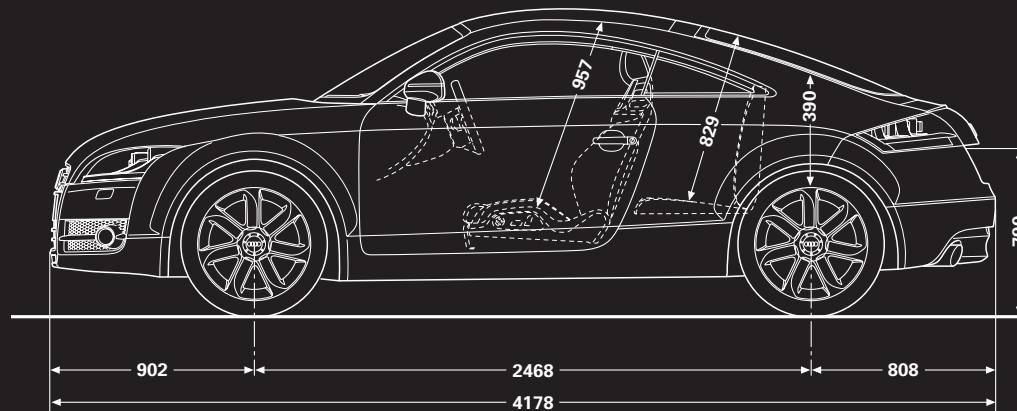
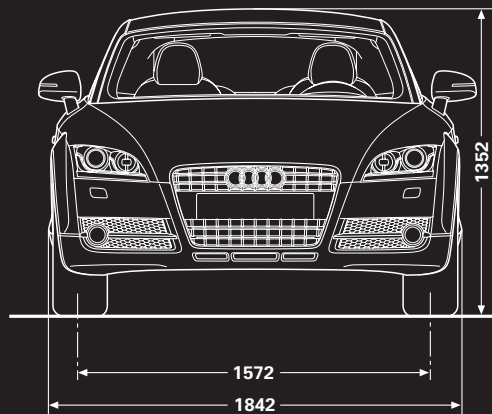
**Dimensions in millimetres.**

Dimensions were measured at unladen weight.

Luggage compartment volume 290/700 l (measured in accordance with the VDA method using 200 x 100 x 50 mm blocks; second figure: with rear seat folded down and the vehicle loaded up to roof height). Turning circle approx. 10.9 m.