



Audi A4





In the future there will be

a car.



Like there has
never been before.
The new Audi A4.

We have been building cars for more than 100 years. A lot has changed in this time. Cars have become more intelligent, safer and more elegant, and provide ever increasing levels of comfort. Can the present-day automobile still spring a surprise? We think it can.

The new Audi A4 is more than an updated development based on many years of experience in the automobile industry. It sets new standards for the rest. Never before have there been so many innovations to make driving more pleasurable and yet more exciting at the same time. Never before have you had so much room in an A4. Never before have you had the opportunity to personalise your car to this extent.

The new Audi A4 is the car of the future. But you can drive it right now.





The new A4.

Unmistakably an Audi – unmistakably a personality. The lively body lines define the classic saloon silhouette. The continuous shoulder line and long bonnet lend a stretched appearance to the car, whilst also giving a dynamic feel to the design. The powerful body, with large-diameter wheels and short front overhang, sends a signal of self-assured sportiness, whilst the extended roof line emphasises its elegance. Discover its character.

The striking face of the new Audi A4.

The V-shaped line of the bonnet culminates in the singleframe radiator grille; the side air intakes blend in harmoniously. The slimline optional Xenon headlights not only look good, but also feature sophisticated technology, a strip of 14 LED lights performing the daytime running light function. LED lights use considerably less energy than normal dipped headlights and have a much longer working life.









The quattro® permanent all-wheel drive in the Audi A4 distributes the driving force dynamically and asymmetrically to all four wheels. If one of the wheels threatens to lose grip, the quattro® system balances this irregularity by re-distributing the forces. The Electronic Stabilization Programme (ESP) ensures greater stability at all speeds through targeted braking of individual wheels and careful intervention in the engine management system.

A detailed view of the front interior of an Audi A4 Quattro. The image shows the driver's side, including the leather-upholstered front seat with perforated Milano leather, the steering wheel with the Audi logo, the dashboard, and the center console with the gear shifter. The car is parked on a road overlooking a scenic landscape with mountains and a body of water under a clear sky.

Take a seat – and enjoy the spacious interior of the A4, whether you sit up front or in the rear. At the front, the optional climate-controlled comfort seats, with their soft-feel design and shaped side bolsters, convey a feeling of luxurious comfort and offer good lateral support. (The seat areas are covered in perforated Milano leather and the seat and backrest surfaces are ventilated and heated. The seat areas of the non-ventilated outer rear seats are also covered in perforated Milano leather.) The climate-controlled comfort seats require the convenient electric seat adjustment facility. This allows you, amongst other things, to adjust the height and angle of the seat cushion and backrest to suit your particular requirements. Excellent comfort is provided by a four-way lumbar support, which is also operated electrically.

The rear seat passengers have it easy too – and not just thanks to their comfortable seating positions, either. The optional three-zone deluxe automatic air conditioner has separate air and temperature controls for the driver, front passenger and for the rear of the cabin. A sensor measures the amount of sunlight falling onto the car and adapts the control accordingly. An activated carbon filter cleans the incoming air of pollutants and pollen and improves the atmosphere in the cabin, whilst a sensitive moisture detector reduces window misting.



The revised cockpit provides a wealth of information. The gear display in the optional driver information system helps you choose the right gear, so that you can actively save fuel; the tyre pressure monitor display warns of any drop in pressure. You can personalise vehicle functions using the Car Menu; and adjust the brightness of the display, the exterior lighting and many other settings to suit your particular needs. The optional Bang & Olufsen Sound System will keep you well entertained, delivering 505 watts of music power through ten channels and fourteen speakers – in surround sound, of course. The standard electro-mechanical parking brake and the high quality screen mounted above the centre console, also fitted as standard, provide greater comfort and convenience. The screen allows you to keep a constant eye on all the information – and is really something quite special in a vehicle of this class.



Cast aluminium wheels, 6-spoke design,
size 7.5 J x 17 with 225/50 R 17 tyres



Cast aluminium wheels, 5-spoke star design,
size 8 J x 18 with 245/40 R 18 tyres



Steel winter wheels including full wheel covers,
size 7 J x 16 with 205/60 R 16 tyres,
suitable for snow chains



Cast aluminium winter wheels,
size 8 J x 18 with 245/40 R 18 tyres,
not suitable for snow chains



Cast aluminium wheels, 7-arm structure design,
size 7.5 J x 17 with 225/50 R 17 tyres

Wheel bolts
with anti-theft locks, can only be loosened using adapter provided

tire mobility system
with 12 volt compressor and tyre sealant

Jack
in the luggage compartment



Lightweight forged aluminium winter wheels, 6-arm design,
size 7 J x 16 with 225/55 R 16 tyres,
suitable for snow chains



Cast aluminium wheels, 10-spoke star design,
size 8 J x 17 with 245/45 R 17 tyres

Vehicle tool kit
in the luggage compartment

Tyre pressure monitoring system
visual and acoustic warning if the pressure drops in one or more tyres; the position of the tyre affected is displayed in the driver information system

Spare wheel, space-saving
including jack, located in the luggage compartment



Cast aluminium winter wheels, 7-arm structure design,
size 7 J x 17 with 225/50 R 17 tyres,
suitable for snow chains



A4 in Meteor Grey pearl effect with cast aluminium wheels with 10-spoke star styling. Equipment: climate-controlled comfort seats in Milano leather cardamom beige, dashboard in tan beige, inlays in Laurel nutmeg, DVD navigation system with MMI, Bang & Olufsen Sound System.



A4 in Aruba Blue pearl effect with cast aluminium wheels with 6-spoke styling.
Equipment: standard seats in Arkana cloth pale grey, dashboard in graphite grey, inlays in Walnut brown, symphony radio with Audi sound system.

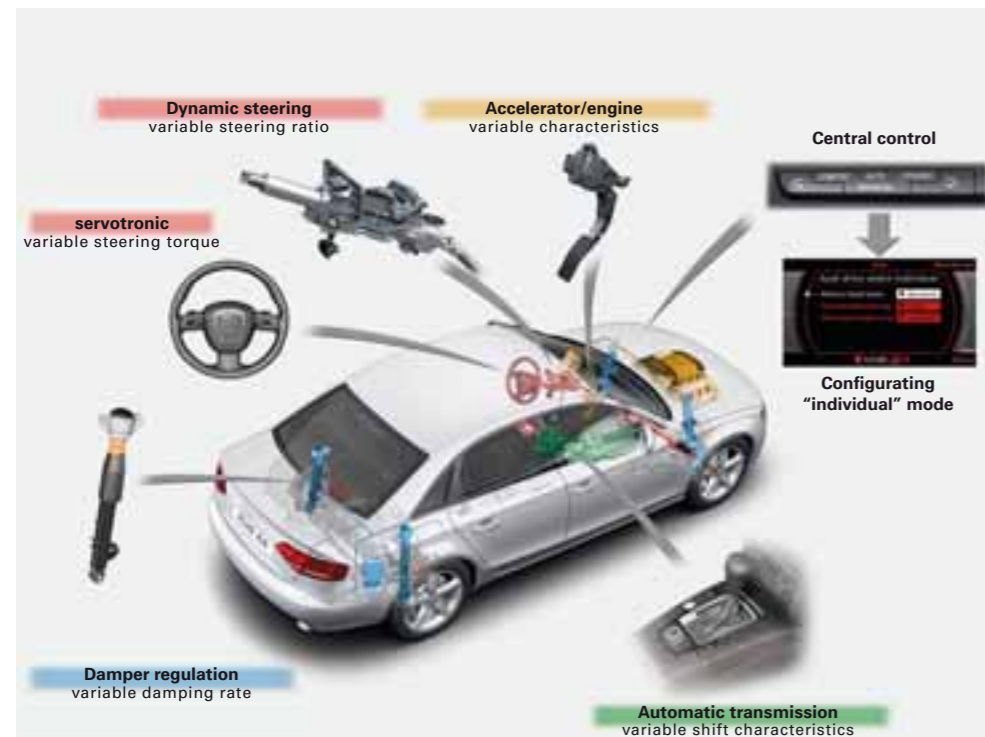

**Audi drive select**

vehicle settings can be changed by selecting one of three modes (comfort, auto and dynamic), or the additional "individual" mode via the MMI. (Can only be ordered with dynamic steering and/or damper regulation)

Dynamic steering

when changing lanes, parking and cornering, this system improves comfort and handling by dynamically regulating steering effort and steer angle according to the driving situation. (Can only be ordered in conjunction with Audi drive select and for 140 kW and higher engine versions)

Damper regulation

superbly adapts the suspension to different driving situations and road surface conditions; vehicle can be lowered by a further 20 mm. (Can only be ordered in conjunction with Audi drive select)

Braking system

dual-circuit, diagonally split braking system, anti-lock braking system (ABS) with electronic brake force distribution (EBD), Electronic Stabilization Programme (ESP) with Brake Assist, tandem brake booster, disc brakes front/rear, ventilated at front

Brake pad wear indicator, front

shown in the centre display

Dynamic suspension

combining outstanding handling with exceptional levels of comfort; five-link light-weight front suspension, tubular anti-roll bar; trapezoidal-link rear axle with independent suspension; twin-tube gas-filled shock absorbers and coil springs, rebound buffer springs, front axle carrier rigidly fixed to the bodywork, flexibly-mounted sub-frame at rear

Sports suspension

lowers vehicle by 20 mm and features stiffer spring and damper tuning for more direct contact with the road and sporty handling; includes suspension brace

S line sports suspension

featuring dynamic suspension tuning; lowers vehicle by a further 10 mm compared with sports suspension. From quattro GmbH

Electromechanical parking brake

includes parking brake function when stationary, drive-off assistance function through automatic release when driving away and emergency braking function whilst driving through action on all four wheels

**Airbags**

Full-size airbags for driver and front-seat passenger with seating position detection; adaptive airbags for driver and front-seat passenger, **sideguard head airbag system, side airbags** (thorax/pelvis airbags at front)

Side airbags, at rear (optional), to supplement side impact protection in the doors

Traction control (ASR)

for excellent traction, prevents the drive wheels from spinning

Audi backguard

in the event of a rear-end collision, the design of the seats restrains the upper torso and supports the head at an early stage of the process. This increases the level of protection and reduces the risk of a whiplash injury

Audi hold assist

holds the vehicle stationary for unlimited periods after stopping, including on uphill and downhill gradients. The system is activated by push-button and allows the driver to drive away smoothly without having to operate the handbrake

Electronic differential lock (EDL)

on roads with varying levels of grip, this drive-off assistant automatically brakes the drive wheels on the surface that is too slippery, thereby ensuring smooth, powerful progress; operates at speeds up to approx. 100 km/h

Audi lane assist

the system uses a front-mounted camera and steer angle sensor to create a virtual driving lane; if there is a danger of the vehicle leaving the lane and the indicator has not been actuated, the driver is warned in the form of steering wheel vibrations. (The grey-coloured strip along the windscreen is omitted; can only be ordered with light/rain sensor and 4-spoke multifunction leather steering wheel)

Audi side assist

at speeds of 60 km/h and above, this system uses radar technology to monitor the area behind and next to the vehicle as it drives along, and informs the driver via an LED display in the exterior mirror if a vehicle is in the blind spot or is approaching from the rear

Audi parking system at rear

makes reverse parking easier by indicating acoustically how far away the vehicle is from an obstacle; measurement is by ultrasonic sensors concealed in the bumpers

Audi parking system plus

acoustic and visual parking aid for front and rear, with display on the screen

**Audi parking system advanced**

acoustic and visual parking aid for the front and rear, image of area behind the vehicle displayed on the screen, reversing camera concealed in the tailgate. (Can only be ordered in conjunction with DVD navigation system with MMI)



100% Audi. 100% service.

Whether midday or midnight. The Audi Service Hotline is open for you round the clock. And thanks to our dense network of Audi partners, help is also quickly at hand. Our services include maintenance and inspection, a courtesy car in the event of your vehicle being off the road, professional repair of accident damage and the comprehensive warranty insurance option Audi CarLife Plus.

Mobility guarantee¹

Free immediate assistance in the event of a breakdown or accident. Your Audi partner will give you a mobility guarantee valid for all new vehicles for two years from time of delivery; can be extended with each inspection carried out by an Audi partner for a maximum of two years. For more information, please contact your Audi partner.

Round-the-clock assistance

In the event of a breakdown you can reach us free-of-charge². For more information and the telephone number for your country, please contact your Audi partner.

Pick-up and delivery service

Pick-up and delivery service for workshop appointments. Your vehicle will be picked up and returned to you by your Audi partner. Prices and conditions vary depending on distance from dealership. For more information, please contact your Audi partner.

Audi CarLife Plus³

A comprehensive follow-up guarantee insurance policy for mechanical and electrical parts is available for your Audi A4 - for the lifetime of your vehicle if you desire it.

Audi Genuine Parts®

Audi Genuine Parts® is a registered trademark. Original Audi design, safety tests and strict process controls during the entire production process ensure a high standard of quality.

¹ Your Audi partner will be happy to inform you whether mobility guarantee is available in your country.

² Your Audi partner will be happy to inform you whether the hotline can be contacted free-of-charge in your country.

³ Your Audi partner will be happy to inform you whether Audi CarLife Plus is available in your country.

Model	A4 1.8 TFSI (88 kW)		A4 1.8 TFSI (118 kW)		A4 3.2 FSI quattro		A4 2.0 TDI (105 kW) with diesel particulate filter	
Engine type	4-cylinder inline petrol engine with direct fuel injection and exhaust-gas turbo-charger		4-cylinder inline petrol engine with direct fuel injection and exhaust-gas turbo-charger		V6 petrol engine with direct fuel injection and Audi valvelift system		4-cylinder inline diesel engine with common rail injection system and exhaust-gas turbocharger	
Displacement in cc (valves per cylinder)	1798 (4)		1798 (4)		3197 (4)		1968 (4)	
Max. output ¹ in kW at rpm	88/3650–6200		118/4500–6200		195/6500		105/4200	
Max. torque in Nm at rpm	230/1500–3650		250/1500–4500		330/3000–5000		320/1750–2500	
Power transmission/wheels								
Type of drive	Front-wheel drive		Front-wheel drive		quattro® permanent all-wheel drive		Front-wheel drive	
Transmission	6-speed manual transmission		6-speed manual transmission [multitronic®]		6-speed manual transmission [tiptronic]		6-speed manual transmission [multitronic®]	
Wheels	Steel wheels with full wheel covers, 7 J x 16		Steel wheels with full wheel covers, 7 J x 16		Forged lightweight wheels, 7.5 J x 16		Steel wheels with full wheel covers, 7 J x 16	
Tyres	205/60 R 16		205/60 R 16		225/55 R 16		205/60 R 16	
Weights/capacities								
Unladen weight ² in kg	1410		1410 [1450]		1580 [1610]		1460 [1495]	
Gross vehicle weight in kg	1960		1960 [2000]		2130 [2160]		2010 [2045]	
Roof load/trailer nose weight in kg	90/80		90/80		90/80		90/80	
Trailer load limit ³ in kg	unbraked	720	740	[750]	750	[750]	750	[750]
	12% gradient	1300	1300	[1300]	1900	[1900]	1700	[1700]
	8% gradient	1500	1500	[1500]	2100	[2100]	1900	[1900]
Fuel tank capacity, approx. in l	65		65		64		65	
Performance/consumption⁴								
Top speed in km/h	208		225 [218]		250 (regulated) [250] (regulated)		215 [210]	
Acceleration 0–100 km/h in s	10.5		8.6 [8.6]		6.2 [6.4]		9.4 [9.4]	
Fuel grade	Super unleaded 95 RON ⁵		Super unleaded 95 RON ⁵		Super unleaded 95 RON ⁵		Diesel in accordance with EN 590	
Fuel consumption ⁶ in l/100 km	urban	9.9	9.9	[10.4]	13.5	[13.6]	7.5	[7.8]
	extra-urban	5.5	5.5	[5.7]	6.7	[6.8]	4.3	[4.7]
	combined	7.1	7.1	[7.4]	9.2	[9.3]	5.5	[5.8]
CO ₂ emissions ⁸ in g/km	urban	236	236	[248]	321	[322]	195	[205]
	extra-urban	131	131	[136]	159	[161]	114	[124]
	combined	169	169	[174]	219	[220]	144	[154]
Emissions standard	EU 4		EU 4		EU 4		EU 4	

[] Data for multitronic® and tiptronic. Explanatory notes ¹ to ⁷ on page 103.

Audi A4

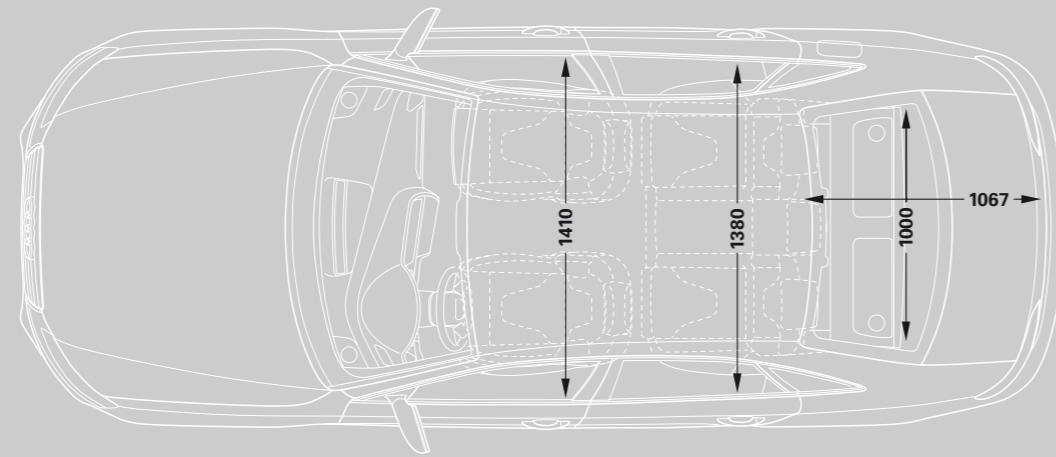
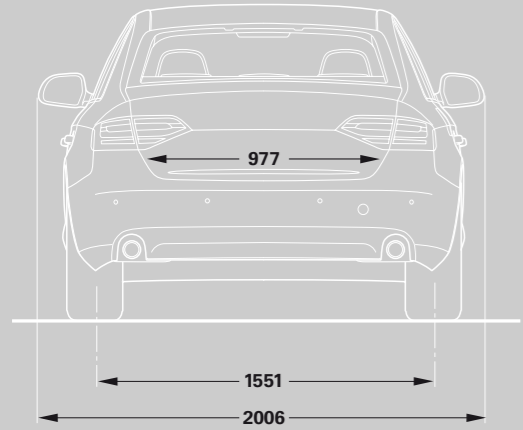
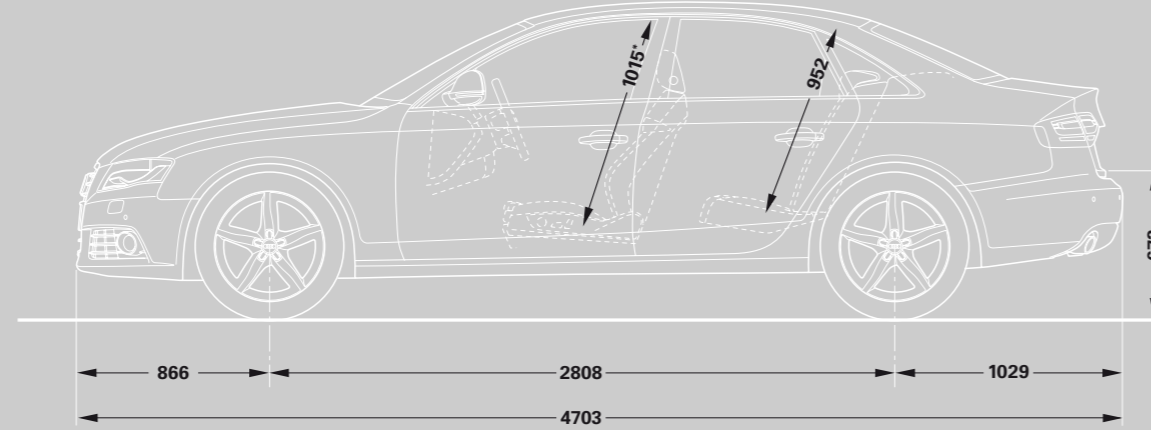
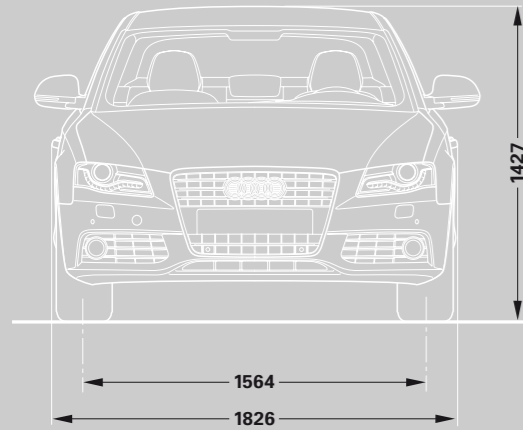

Dimensions in millimetres.

Dimensions are for vehicle at unladen weight.

Luggage compartment volume 480/962 litres (measured by the VDA method, using 200 x 100 x 50 mm blocks; second value with rear seat back folded down and vehicle loaded up to the rear parcel shelf).

Turning circle approx. 11.5 m.

*Maximum headroom.

Vorsprung durch Technik www.audi.com.au

The models and equipment versions illustrated and described in this brochure and some services listed are not available in all countries. Some of the cars illustrated are equipped with optional equipment for which an extra charge is made. Details concerning the delivery specifications, appearance, performance, dimensions and weights, fuel consumption and running costs of the vehicle were correct to the best of our knowledge at the time of going to press. There may be some variations between the Australian vehicle specifications and those manufactured for other markets. Please speak to your Audi Dealer should you have any questions. Deviations from the colours and shapes shown in the illustrations may occur. No liability is accepted for errors and printing errors. The right to introduce modifications is reserved. Not to be reproduced, including in part, without the written approval of Audi AG.

This brochure is printed on paper made from pulp bleached without the use of chlorine.

AUDI AG
85045 Ingolstadt
www.audi.com
Valid from November 2007

Printed in Germany
733/1204.46.18