



Audi Q7



**As far as this is concerned,
nothing's changed.**

Harald Demuth covered a distance of 78 m in his Audi 100 quattro® in 1986. Just a short distance. But long enough to engrain the fascination for the quattro® drive into the consciousness of an entire generation. Because these 78 m were not exactly easy going. The German rally master of 1982 and 1984 not only had to command the 37-degree incline and a snow-covered ground, but also himself. Never before had a person climbed a snowed-over ski jump in a car. Harald Demuth kept cool. And the Audi quattro® too. Powerfully and impressively it mastered the 80 percent incline of the jump in Kaipola, Finland. A few seconds of driving, which were beamed all around the world and made not only quattro® but also the fundamental Audi principle famous to everybody: Vorsprung durch Technik.

Once again, with the Audi Q7, Audi succeeds in astonishing the world and demonstrating exactly what Vorsprung durch Technik means. The Audi Q7 takes the successful quattro® drive idea forwards and into a new dimension. With a sporty design and powerful engines it's showing off its original roots: driving enjoyment, power and dynamism. It sets new benchmarks with exceptional comfort and a generous amount of space. A car, which confidently takes you to any destination. Which is at home on any road. And also where there aren't any.





The Audi Q7 shows its urge to push forward from the back as well. Its rear is puristic and succinct at the same time. One innovation in the SUV segment is the encompassing tailgate, which lends dynamism to the rear. It is separated from the body by a distinctive S-joint, which emphasises the expression of high performance and completely integrates the continuous rear lights into the tailgate. The high bumper lends the Audi Q7 a robust and powerful appearance.



Where there's an Audi Q7 there's a way. With the optionally available adaptive air suspension (standard for 4.2 TDI) it gives you even more independence. This directly intervenes in damping the individual wheels. By eliminating permanent car body movements and automatically reducing rolling or pitching motions when cornering, braking or starting up it ensures a comfortable driving feeling and more grip.

Adaptive air suspension gives the Audi Q7 the variable ground clearance, which defines an SUV. At the same time, it combines the sporty driving character of a Coupé with the excellent suspension comfort of a saloon, by enabling damping and vehicle height to be variably regulated. The damper adjustment and height, and with this the handling, can be individually controlled in five stages. With just one move of the hand you can switch between automatic, comfort, dynamic, off-road and lift modes using the MMI.

The optional comfort and dynamic settings ensure excellent driving comfort or improved handling. In all stages the adaptive air suspension independently lowers the body appropriately for the speed and adjusts the dampers accordingly. Lowering the vehicle height at greater speeds creates a lower centre of gravity, noticeably increasing the driving stability. The off-road mode raises the trims by 25 mm, allowing off-road driving at up to 100 km/h. On impracticable terrain or when slowly driving over large obstacles the lift setting assists you by raising the trims by 60 mm. Alongside these diverse characteristics, adaptive air suspension also works as classic height regulation. It keeps the trims in a constant position, independent of load.



As well as driving stability, the Electronic Stabilization Programme ESP also takes care of the braking process. With its numerous functions the system assists the large-dimensioned braking system. Its drying function removes water from the brake discs if the road is wet and considerably improves the braking effect. If the driver doesn't push the brake pedal hard enough in an emergency braking situation the ESP's hydraulic Brake Assist recognises the attempt to brake fully and gives the signal for full brake pressure. During the full braking process, the reliable anti-lock braking system ABS then provides control and increases the tractability. The aerodynamics of the Audi Q7 on the other hand reduce the thermal load on the brakes. Channels under the vehicle divert the air flow past the brake discs, ensuring cooling.

Numerous passive systems round off the Audi Q7's safety concept. The rigid and stable passenger cell fulfils all current crash standards. The standard driver and passenger airbags activate in the event of a collision in about 40 milliseconds – in two stages and adjusted to the severity of the collision. In addition, side airbags at the front and the side-guard head airbag system are included in the Audi Q7 as standard. sideguard works from the first to the third row of seats and covers almost the entire side window area. Extra side airbags for the second row of seats are available if desired.





Multifunctionality doesn't have to be complicated. The Audi Multi Media Interface MMI takes care of this. Just one move of the hand and the central control system in the Audi Q7 gives you rapid access to important vehicle information and functions: depending on equipment, radio, CD, Audi music interface or TV, your telephone as well as traffic announcements and the navigation system. It is controlled via the MMI terminal with function keys and the central control button. The MMI display is located in the centre of the dashboard and shows the requested information.

The Audi Q7 is fitted with MMI basic as standard, which includes radio and CD functions as well as basic vehicle settings. The optionally available MMI basic plus extends the basic equipment to include the option of saving radio traffic announcements and a DSP sound system with eleven loud speakers. The MMI top version offers a colour 7-inch display as well as a CD changer compatible with MP3 and WMA formats. If required, it is also available with a DVD navigation system, amongst other things.

The Audi music interface is provided for running portable MP3 players such as the iPod (generation 4 and higher). This interface allows you to control the player's function both via the MMI and using the multi-function steering wheel. Please contact your Audi partner for information on the compatibility of MP3 players produced by other manufacturers.

The Audi Q7 gives everything it has to make its operation as straightforward as possible for you. This begins as soon as you get in. With the optionally available advanced key the Audi Q7 automatically recognises you and unlocks itself as soon as you activate the door or tailgate. You can also start and stop the engine just as conveniently without having to insert the key in the ignition: a single press of the start/stop button in the centre console is all it takes.

The Audi Q7 will even help you with parking. The Audi parking system warns you acoustically when it recognises obstacles behind the vehicle. The optionally available Audi parking system plus also keeps an eye on the area in front of the Audi Q7 and warns you by means of both an acoustic signal and visually via the MMI. In the top version Audi parking system advanced, the Audi Q7 is additionally equipped with a reversing camera. The display appears on the MMI screen. Guidelines are incorporated into the camera image; parking and hitching trailers is easier than it has ever been.

Sometimes you just can't decide what to take with you. This is why, with up to 28 possible seating and loading configurations, the Audi Q7 grants you all the freedom you could require. Unique in its class, it offers a 775 litre boot volume behind the second row of seats and the loading space comprises a whole 330 litres when there are seven people in the vehicle. By tilting the rear seats (all rear seats can be lowered level to the loading area) the loading volume can be increased by up to 2,035 litres as standard. The generous loading width of 1.22 metres is unique in its class and offers room for four golf bags lying sideways, for instance. There is a large through-loading facility located in the second row of seats as standard. If these are folded down, the loading area offers enough space to stow, for example, snowboards or skis, quickly and with ease. The optional reliable Audi securing rail system offers even more transportation options. With telescopic bars and an adjustable fastening belt you can divide the luggage compartment as you require and fix objects securely.

The Audi Q7 helps out when loading and unloading with the optionally available adaptive air suspension: the loading sill can be lowered at the touch of a button in the luggage compartment. It is even more convenient to load luggage with the optionally available electric tailgate with programmable opening angle. This can be comfortably operated with one hand.

The Audi Q7 also offers plenty of storage space for the many small things which you like to have around you when out and about. CDs or street maps can be stowed away with no problem in the various storage areas, in the drawer beneath the passenger seat and in the large pockets in the doors. Drinks can be kept in the bottle holders, which even take 1.5 litre bottles, or in the numerous drinks holders. There is even an extra storage compartment for sunglasses. And anything messy or dirty can be stowed away in the dirt tray in the luggage compartment.





Seats with seat covers in black/magnolia two-tone look in Fine Nappa leather.



Steering wheel rim with coloured seam detail.



Tamo ash dark brown inlay.



Gear lever gaiter with coloured seam detail.

Audi exclusive line

Black interior (including black attachments)

Headlining in black cloth

Two-tone seat covers (seat side bolsters black/seat centre panel optionally in magnolia, silver or cognac) in Fine Nappa leather (standard seats); optional: sports seats

Door panel inserts (to match seat centre panels)

Audi exclusive sill trims

Matt brushed aluminium inlay;
optional: Tamo ash dark brown or Piano finish black

Floor mats with coloured piping (to match seat centre panels)

Comfort centre armrest trimmed in leather

Multifunction leather steering wheel in 4-spoke styling, with coloured seam detail (to match seat centre panels),
optional: multifunction sports leather steering wheel in 3-spoke styling, with gearshift function and coloured seam detail (to match seat centre panels)

Seat side bolsters, head restraints, steering wheel rim and gear lever gaiter with coloured seam detail (to match seat centre panels)



S line – Experience sportiness.

Take the Audi Q7 to even sportier dimensions – with the two S line packages. The S line exterior package, with striking sporty body-coloured bumper and lower door cover strips, plus radiator grille painted in Brilliant Black, lend your Audi Q7 an athletic look. Even more driving enjoyment can be had with the S line sports package. This is assured by the attractive 20-inch cast aluminium wheels, the S line sports suspension and, in the interior, by the Alcantara/Leather black or black Verano leather sports seats with S line emblem, an S line multifunction sports leather steering wheel with contrasting seams and matt brushed aluminium inlays. Still can't decide? Why not simply combine both S line packages.



Audi Q7 in Ice Silver metallic with contrasting paint in Platinum Grey matt; with cast aluminium wheels in polished two-tone 5-double-spoke styling, size 9 J x 20 with 275/45 R 20 tyres. Sport design package: sports seats in Alcantara/Leather black, Aluminium Marlin silver inlays, black dashboard, multifunction sports leather steering wheel in 3-spoke styling.



Audi Q7 in Lava Grey pearl effect with contrasting paint in Platinum Grey matt; with cast aluminium wheels in 7-arm structure styling, size 8.5 J x 19 with 265/50 R 19 tyres. Leather plus design package: standard seats in cardamom beige Verano leather, Tamo ash dark brown inlays, black/borneo green dashboard, multifunction sports leather steering wheel in 3-spoke styling.



Model	AUDI Q7 3.6 FSI quattro	AUDI Q7 3.6 FSI quattro	AUDI Q7 4.2 FSI quattro
Engine type	V6 petrol engine, direct fuel injection	V6 petrol engine, direct fuel injection	V8 petrol engine, direct fuel injection
Displacement in cc (valves per cylinder)	3597 (4)	3597 (4)	4163 (4)
Max. output¹ in kW at rpm	206/6200	206/6200	257/6800
Max. torque in Nm at rpm	360/2500–5000	360/2500–5000	440/3500

Power transmission/wheels

Type of drive	quattro®	quattro®	quattro®
Transmission type	6-speed manual transmission	6-speed tiptronic	6-speed tiptronic
Wheels	Aluminium 7.5 J x 18	Aluminium 7.5 J x 18	Aluminium 8 J x 18
Tyres	235/60 R 18	235/60 R 18	255/55 R 18

Weights/capacities

Unladen weight² in kg	2195	[2225]	2205	[2235]	2240	[2270]	
Gross weight³ in kg	2890	[3020]	2900	[3030]	2935	[3065]	
Roof load/trailer nose weight in kg	100/140	[100/130]	100/140	[100/130]	100/140	[100/130]	
Trailer load limit⁴ in kg	750		750		750		
	unbraked		unbraked		unbraked		
	12% gradient	3500	[3200]	3500	[3200]	3500	[3200]
	8% gradient	3500	[3200]	3500	[3200]	3500	[3200]
Fuel tank capacity, approx. l	100		100		100		

Performance/consumption⁵

Top speed⁶ in km/h	225/230 ⁷	225/230 ⁷	244/248 ⁷	
Acceleration 0–100 km/h in s	8.3	8.5	7.4	
Fuel grade	SuperPlus 98 RON ⁸	SuperPlus 98 RON ⁸	SuperPlus 98 RON ⁸	
Fuel consumption⁹ in l/100 km	urban	18.1	17.8	19.5
	extra-urban	10.0	9.8	10.2
	combined	12.9	12.7	13.6
CO₂ emission⁹ in g/km	urban	432	425	468
	extra-urban	239	235	245
	combined	309	304	326
Emissions standard	EU4	EU4	EU4	

Off-road properties

Climbing ability as %	60	60	60
Ground clearance in mm	204.8/239.8 ⁷	204.8/239.8 ⁷	204.8/239.8 ⁷
Approach angle in °	front	21.9/max. 24.0 ⁷	21.9/max. 24.0 ⁷
	rear	23.4/max. 25.4 ⁷	23.4/max. 25.4 ⁷
Ramp breakover angle in °	21.1/23.8 ⁷	21.1/23.8 ⁷	21.1/23.8 ⁷
Fording depth in mm	500/535 ⁷	500/535 ⁷	500/535 ⁷

[] Data for 6 and 7-seater versions.

Model	AUDI Q7 3.0 TDI quattro	AUDI Q7 4.2 TDI quattro
Engine type	V6 diesel engine with turbocharging and common rail technology	V8 diesel engine with turbocharging and common rail technology
Displacement in cc (valves per cylinder)	2967 (4)	4134 (4)
Max. output¹ in kW at rpm	171/4000	240/3750
Max. torque in Nm at rpm	500/1750–2750	760/1800–2500

Power transmission/wheels

Type of drive	quattro®	quattro®
Transmission type	6-speed tiptronic	6-speed tiptronic
Wheels	Aluminium 7.5 J x 18	Aluminium 8 J x 18
Tyres	235/60 R 18	255/55 R 18

Weights/capacities

Unladen weight² in kg	2295	[2325]	2420	[2450]	
Gross weight³ in kg	2990	[3120]	3115	[3245]	
Roof load/trailer nose weight in kg	100/140	[100/130]	100/140	[100/130]	
Trailer load limit⁴ in kg	750		750		
	unbraked		unbraked		
	12% gradient	3500	[3200]	3500	[3200]
	8% gradient	3500	[3200]	3500	[3200]
Fuel tank capacity, approx. l	100		100		

Performance/consumption⁵

Top speed⁶ in km/h	210/216 ⁷	236 ⁷	
Acceleration 0–100 km/h in s	8.5	6.4	
Fuel grade	Diesel to EN 590	Diesel to EN 590	
Fuel consumption⁹ in l/100 km	urban	14.6	14.9
	extra-urban	8.3	8.9
	combined	10.5	11.1
CO₂ emission⁹ in g/km	urban	392	393
	extra-urban	223	236
	combined	282	294
Emissions standard	EU4	EU4	

Off-road properties

Climbing ability as %	60	60
Ground clearance in mm	204.8/239.8 ⁷	239.8 ⁷
Approach angle in °	front	21.9/max. 24.0 ⁷
	rear	23.4/max. 25.4 ⁷
Ramp breakover angle in °	21.1/23.8 ⁷	23.8 ⁷
Fording depth in mm	500/535 ⁷	535 ⁷

[] Data for 6 and 7-seater versions.

Notes

¹ The value stated has been calculated using the specified measuring procedure (current applicable version of Directive 80/1269/EEC).

² Weight of car, unladen, without driver (calculated in accordance with the current applicable version of Directive 92/21/EEC). Optional equipment may increase the car’s unladen weight and drag coefficient, whereupon the possible payload limit and the top speed will be reduced accordingly.

³ The payload increases by 100 kg for 6 and 7-seaters.

⁴ The engine’s power output always goes down with increasing altitude. At 1000 m above sea level, and for every additional 1000 m, deduct 10% from the weight of the outfit (trailer load limit + gross weight of the towing vehicle). Value applies to trailer load for factory-fitted trailer towing hitch.

⁵ A vehicle’s fuel consumption and CO₂ emissions do not just depend on how efficiently the vehicle uses the fuel but are also affected by driving behaviour and other non-technical factors. CO₂ is the greenhouse gas primarily responsible for global warming.

⁶ Top speed is achieved in 6th gear.

⁷ Value applies to air suspension.

⁸ We recommend using SuperPlus unleaded with 98 RON. If this is not available, use super unleaded (95 RON); power output will be slightly reduced.

⁹ The values stated have been calculated using the specified measuring procedure (current applicable version of Directive 80/1268/EEC). The figures do not refer to one individual vehicle and do not form part of any offer, but rather should be used purely for purposes of comparison between the different vehicle models.

Important note

Inspections are due as shown on the service display.

Audi Q7 5-seater

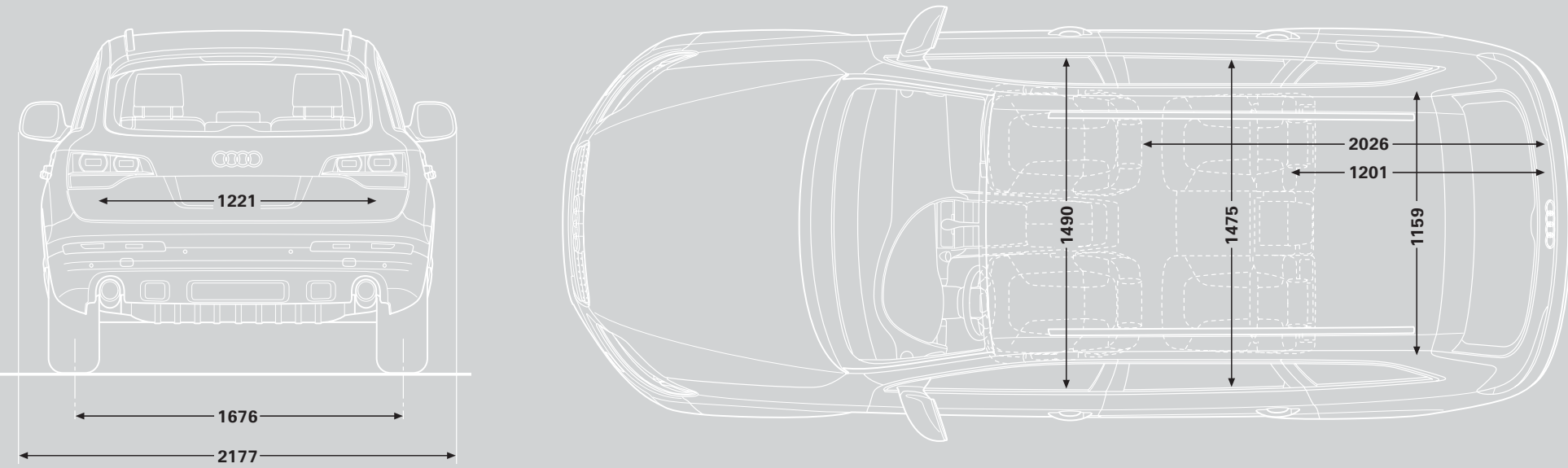
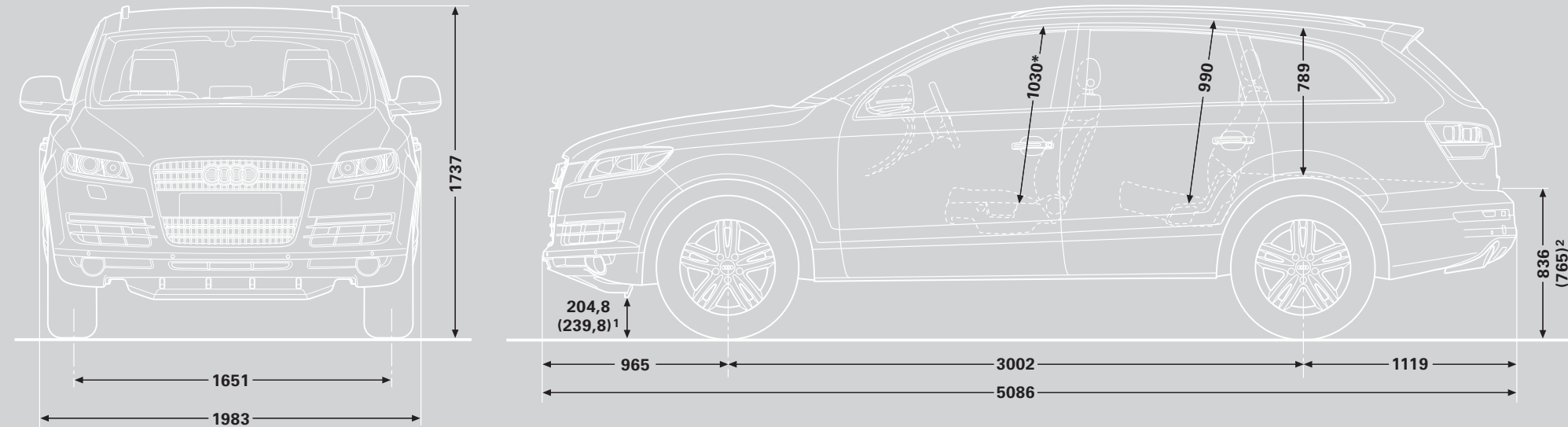

Dimensions in millimetres.

Dimensions were measured with vehicle at unladen weight, ground clearance measured with vehicle carrying its maximum load. Luggage compartment volume in l: 775/2035 (measured by the VDA standard test method using 200 x 100 x 50 mm blocks. Second value is with the rear seat folded down and the vehicle loaded up to roof height). Turning circle approx 12 m.

* Maximum headroom.

¹ With optional air suspension, in lift mode.

² With optional air suspension, at loading level.

Audi Q7 7-seater

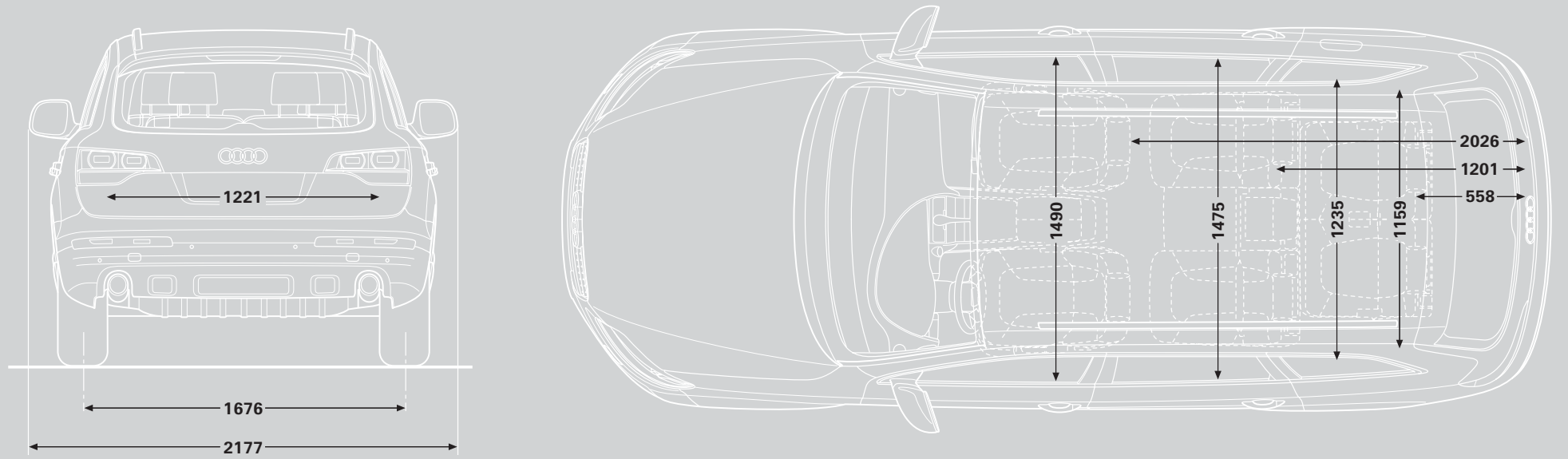
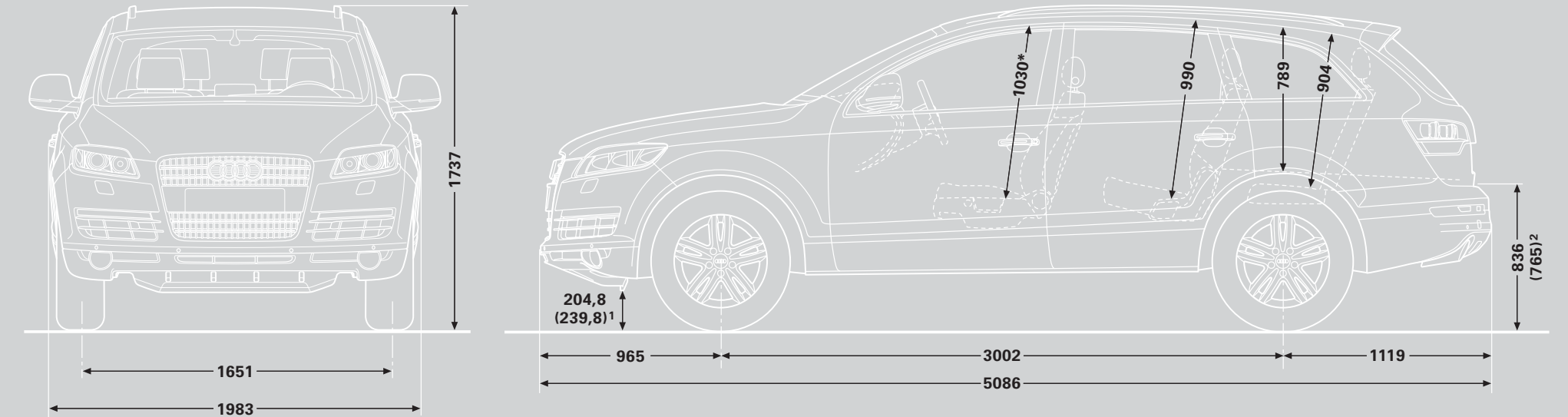

Dimensions in millimetres.

Dimensions were measured with vehicle at unladen weight, ground clearance measured with vehicle carrying its maximum load. Luggage compartment volume in l: 775/2035 (measured by the VDA standard test method using 200 x 100 x 50 mm blocks. Second value is with the rear seat folded down and the vehicle loaded up to roof height). Turning circle approx 12 m.

* Maximum headroom.

¹ With optional air suspension, in lift mode.

² With optional air suspension, at loading level.

Vorsprung durch Technik www.audi.com.au

The models and equipment versions illustrated and described in this brochure and some services listed are not available in all countries. Some of the cars illustrated are equipped with optional equipment for which an extra charge is made. Details concerning the delivery specifications, appearance, performance, dimensions and weights, fuel consumption and running costs of the vehicle were correct to the best of our knowledge at the time of going to press. There may be some variations between the Australian vehicle specifications and those manufactured for other markets. Please speak to your Audi Dealer should you have any questions. Deviations from the colours and shapes shown in the illustrations may occur. No liability is accepted for errors and printing errors. The right to introduce modifications is reserved. Not to be reproduced, including in part, without the written approval of Audi AG.

Valid from April 2007

Printed in Germany

733/1104.70.18