



Audi

S6



*To know your limits,  
you have to overcome them.*

S. A letter that at Audi stands for “Sport” – and for much more besides.

A letter that has inspired many sensational moments since time immemorial. Whether in motor racing or in production. But S is also the Audi philosophy of venturing along paths where no one has gone before. Reaching limits and going beyond them. Innumerable motor racing victories are witness to that. The Audi S1 was the first Audi to bear an S in its name. And it is one of the most powerful rally cars of all time. It is the only car to have won the feared Pikes Peak Colorado race three times in succession.

But the story doesn't end there. On the contrary. It is just about to begin one of its most exciting chapters: in the Audi S6. Learn more about this breathtaking letter.





*We can only guess what drives you.  
You can feel what drives the S6.*

An idea that has been a success story from the very beginning can sometimes even be too successful. Hence, since 1992, Audi has not been permitted to use the quattro® drive in the German Touring Car Championship. For our engineers both praise and frustration at the same time. But above all an extreme incentive to continue to build cars that set standards. The result is the Audi S6. Thanks to this car, the sensation of quattro® permanent all-wheel drive can be felt by everyone – even outside the race track. Improved handling and power distribution to the front and rear axles, as required by the driving situation, give you more traction on almost any road surface and let you enjoy the convincing power of the V10 FSI® high-performance engine. Particularly where other vehicles lack propulsion. An advantage that is great fun.

Fuel consumption and CO<sub>2</sub> emissions figures can be found on page 43.





Challenges are the most wonderful thing in the world for engineers. Particularly when the goal in mind is to develop such an exceptional car as the Audi S6. So the task of how to transfer the power of the Audi S6 onto the road was a tricky one. The quattro® permanent all-wheel drive renders an indispensable service. But a suspension especially tuned to the power characteristics of the Audi S6 gives the driver that special driving sensation. Thanks to the sports suspension, undesirable longitudinal and lateral movements of the body when starting off, braking or during load changes are for the most part avoided. Directional stability is also assisted as is steering response in interaction with servotronic. The result is a pure experience. Agility and sporty driving in its very own form, combined with the comfort of a luxury saloon car. Anyone driving the Audi S6 will certify with an enthusiastic smile that the engineers have mastered all their challenges.

Sporty ambition simply cannot be stopped. In that, the people driving the Audi S6 feel exactly the same as those who developed it. And only with this motivation has the Audi S6 become what it is today: a sports saloon that brings forth enthusiasm from the very first second. One reason for that is, amongst others, the brake system, which is at least as important as the power and the torque of the engine. Because the facts of the Audi S6 are just as impressive as the acceleration values when it comes to braking. The 18-inch high-performance braking system slows down its 320 kW at any desired moment. Technology that ensures the same driving enjoyment as the acceleration.

***Sporty ambition: unstoppable.***

***For everything else: the 18-inch braking system.***



*A design that lets you experience real sportiness.*

Figures and data underline what a power package the Audi S6 is. But what about its design? Its shape? Its impact? These are things you have to experience with all your senses - quite literally. That is exactly the reason why the Audi A6 has so many details and features that just have to be mentioned. The wider front wings and the special S front-end design, including the S6 emblem, are particularly striking. Let your eyes follow the line till they meet a quintessential feature: the strip of LED daytime running lights along the top edge of the side air inlets. Equally distinctive, and worthily underlining the sporty character of the Audi S6, are the aluminium-look exterior mirrors with integral LED indicators. The V10 emblem on the side gives a hint of the engine's performance: a statement, that almost rivals the black painted brake callipers, the front ones bearing the S6 emblem. Not to mention the four oval tailpipes of the Audi S6, which together with the rear diffuser round off the sporty design and perfectly harmonise with the rear spoiler. As you can see, the Audi S6 demands all your senses.











*Trust the power of your imagination. The Audi S6.*



**Dimensions S6**

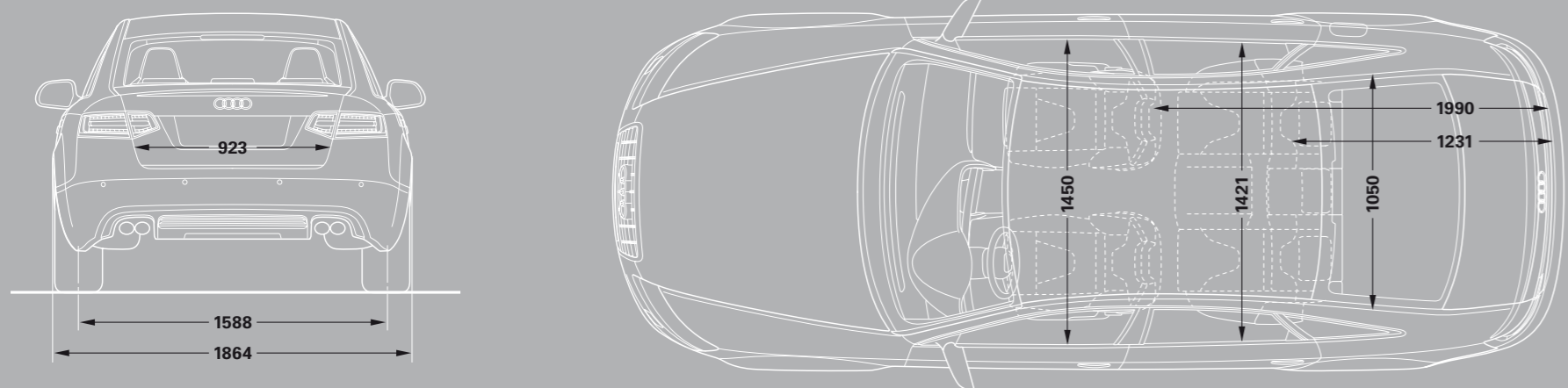
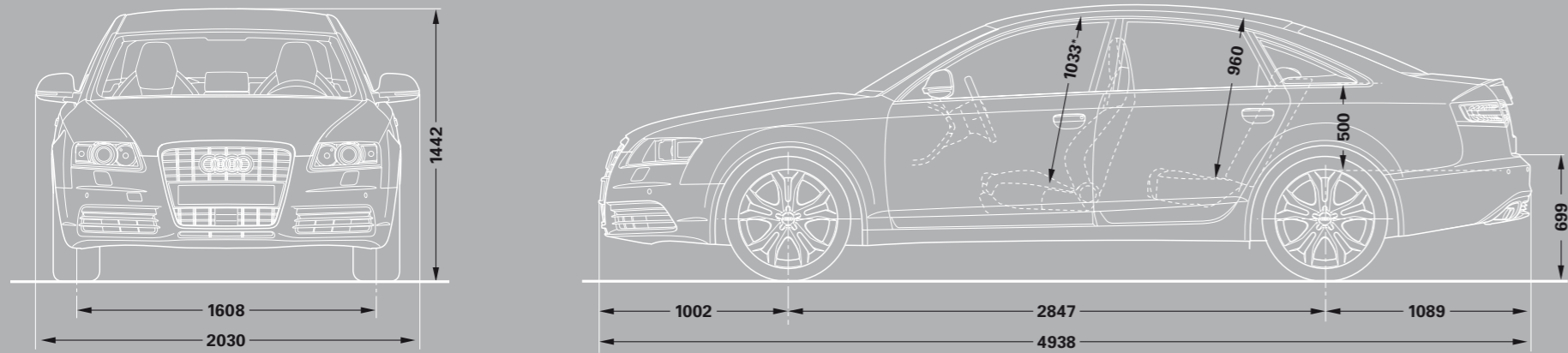

**Dimensions in millimetres.**

Dimensions were measured with vehicle at unladen weight, ground clearance measured with vehicle carrying its maximum load.  
 Luggage compartment volume 546 l (measured by the VDA method using 200 x 100 x 50 mm blocks).  
 Turning circle approx. 11.9 m  
 \*Maximum headroom.

**Dimensions S6 Avant**

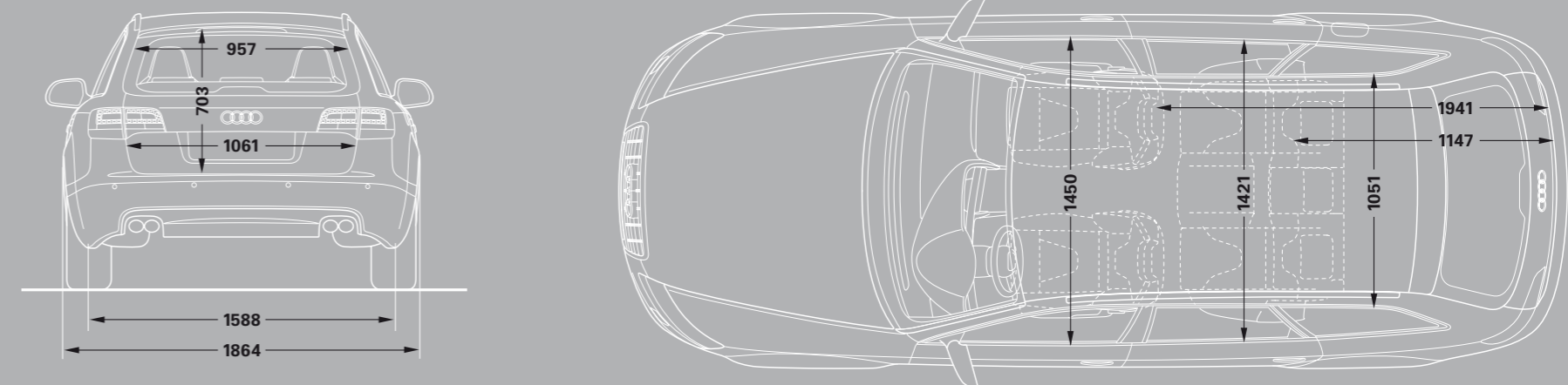
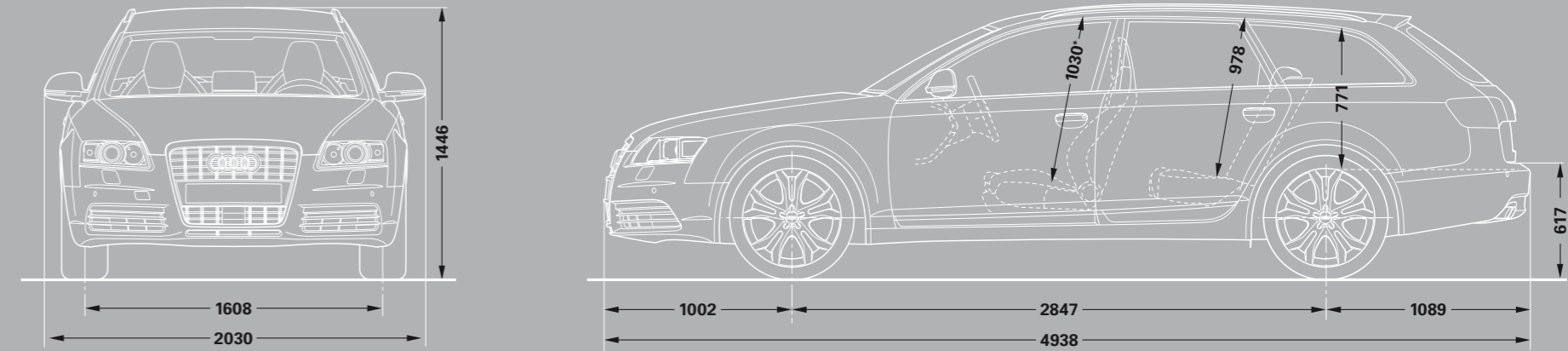

**Dimensions in millimetres.**

Dimensions were measured with vehicle at unladen weight, ground clearance measured with vehicle carrying its maximum load.  
 Luggage compartment volume 565 l; 1,660 l with seat backrests folded down and vehicle loaded up to roof height  
 (measured by the VDA method using 200 x 100 x 50 mm blocks). Turning circle approx. 11.9 m.  
 \*Maximum headroom.

The models and equipment versions illustrated and described in this brochure and some services listed are not available in all countries. Some of the cars illustrated are equipped with optional equipment for which an extra charge is made. Details concerning the delivery specifications, appearance, performance, dimensions and weights, fuel consumption and running costs of the vehicle were correct to the best of our knowledge at the time of going to press. There may be some variations between the Australian vehicle specifications and those manufactured for other markets. Please speak to your Audi Dealer should you have any questions. Deviations from the colours and shapes shown in the illustrations may occur. No liability is accepted for errors and printing errors. The right to introduce modifications is reserved. Not to be reproduced, including in part, without the written approval of Audi AG.