



Audi TT





Pure design.



The Audi TT is a design icon. Since pen was first put to paper, a single rule has prevailed: form follows function. This rule is expressed in every line of the TT. As a result, the TT simply takes your breath away.



Short overhangs at the front and rear and a broad track. Impressive looks, an impressive stance.
A sports car with a captivating design. A design that makes the concept of sportiness tangible.



TT lines. The TT's character was clear right from the first design study. The roof line spans the flat passenger compartment like a cupola. Flowing into the powerful shoulder line. To this are added the flared wheel arches, the twin tailpipes and the wide track.



The message: the Audi TT is a real sports car. Its powerful lines speak a captivating form language. From its athletic side lines to its muscular rear-end design, it radiates pure self-confidence.



The Audi TT Roadster is the epitome of open-top driving enjoyment. Optional extras include the fully-automatic hood and an electrically extendable anti-buffet screen – feel the wind in your hair in just 12 seconds. The fully-automatic hood retracts completely. So handling the hood is equally a pure pleasure.



Purism in its most beautiful form. Functional design meets timeless aesthetics.



Flowing transition from the outside to the inside. The statement of the TT shoulder line, the round air vents, the sports leather steering wheel with flat base. Clear instruments. Clear forms, clear statements. Nothing to distract from the absolutely essential. Even the cockpit is driver-centred.

Pure driving pleasure.

While you steer your TT, your TT steers the lights. The optional adaptive light system for the Audi TT lights up corners and bends as you approach them instead of waiting till you are driving through them. The Audi TT handles corners at high speeds thanks to its outstanding road holding. Choose from two engine variants. Torquey, dynamic, powerful.



**Manual hood**

Made from insulated 3-layer fabric, including integrated, manually-operated cover flaps. (For TT Roadster only)

**Fully automatic hood**

Made from insulated 3-layer fabric providing improved noise and thermal insulation for the interior; includes integrated, fully automated cover flaps, hood headlining in black; hood opens in 12 seconds. (For TT Roadster only)

Anti-theft alarm

Including interior monitoring and anti-tow away function using angle of inclination sensor, can be deactivated; horn operates independently of vehicle electrical system; monitors engine and luggage compartments, doors and interior

Fitting for locating assistant

Fitting for connecting a locating assistant, with which the vehicle can be located if stolen

Radio remote control

For central locking incorporated into the vehicle key, with one touch of the button the system opens and locks doors, windows and luggage compartment – with variable code

Garage door opener (HomeLink)

Programmable radio remote control, controls integrated into the interior light module; can be used to open and close garage doors and exterior gates; can be used to control security and lighting systems. For more information, please contact your Audi partner.

Gas strut

For engine compartment and tailgate

Windscreen with grey strip

Along top edge

Rear window, heated

With timer switch. Integral window aerial. (For TT Coupé only)

Windscreen cleaning system

Two speeds, 4-speed adjustable intermittent wipe, flick-wipe function, automatic wash/wipe, automatic wiping after the last wash/wipe process

Heat-insulating glass

Green-tinted, windscreen made of laminated glass

Dark-tinted windows (privacy glazing). The following windows are dark-tinted: rear side windows and rear window. From quattro GmbH

**Rear spoiler**

can be extended electrically depending on vehicle speed; automatically extends at 120 km/h, retracts at 80 km/h; can also be controlled manually using a button in the centre console

Radiator grille

Painted in Grey (four-cylinder models)
Painted in highly polished Black (3.2 quattro)

Exhaust tailpipes

Twin tailpipe on left (four-cylinder models)
Dual-branch tailpipes, left and right (3.2 quattro)

TT logo

On rear and in rev counter

Bumpers

Plastic-covered, body-coloured

Tyre repair kit

12V compressor and tyre sealant in luggage compartment, maximum speed 80 km/h. (Not available in conjunction with wheels with run-flat tyres)

Jack**Vehicle tool kit**

In the luggage compartment

**Aluminium tank cap**

With embossed TT logo

Wheel bolts, anti-theft

Can only be loosened using adapter provided

Run-flat tyres

Continuation of the journey without changing the tyre is possible with a flat tyre up to an emergency range of 50 km, at a maximum speed of 80 km/h

Tyre pressure monitoring system

Monitors the tyres throughout the journey based on the air pressures set and programmed into the system by the driver; if one or more tyres start to deflate, the tyre pressure monitor uses the difference in the rotational speed and the natural frequency of the wheels to calculate the air loss and gives the driver a visual and audible warning; if a driver information system is fitted, the position of the tyre in question will be displayed. The system is not intended as an alternative to carrying out regular tyre pressure checks



Audi exclusive cast aluminium wheels, 5-spoke design,
size 9 J x 18 with 245/40 R 18 tyres.
From quattro GmbH



Audi exclusive cast aluminium wheels, 7-double-spoke design,
size 9 J x 19 with 255/35 R 19 tyres.
From quattro GmbH



Audi exclusive cast aluminium wheels, 10-spoke design,
size 9 J x 18 with 245/40 R 18 tyres.
From quattro GmbH



Audi exclusive cast aluminium wheels, 7-double-spoke design, titanium-look,
size 9 J x 19 with 255/35 R 19 tyres.
From quattro GmbH



Audi exclusive cast aluminium wheels in 20-spoke design, two-piece,
size 9 J x 19 with 255/35 R 19 tyres.
From quattro GmbH



Audi exclusive cast aluminium wheels, 5-segment spoke design,
size 9 J x 19 with 255/35 R 19 tyres.
From quattro GmbH

Paints

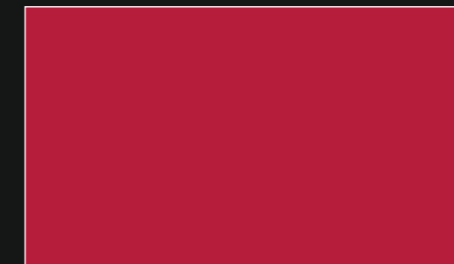

Brilliant Red C8

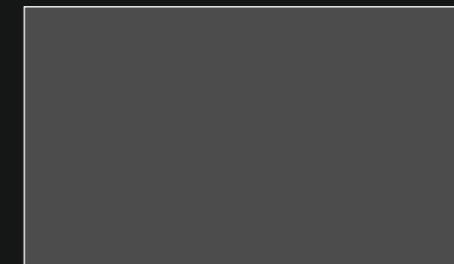

Ice Silver, metallic P5

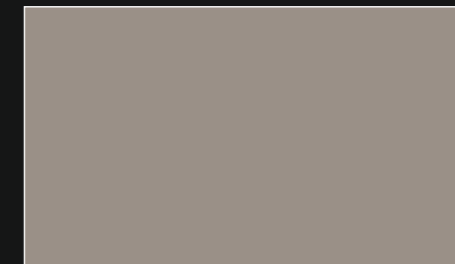

Sahara Silver, metallic 9T

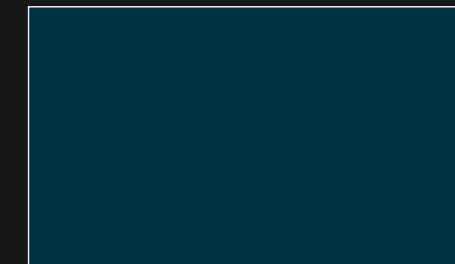

Petrol Blue, pearl effect M7

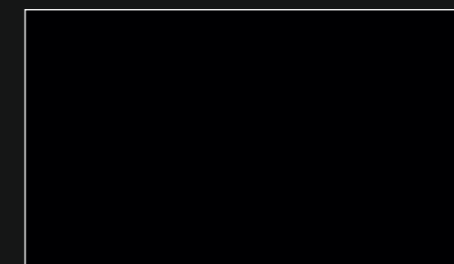

Brilliant Black A2

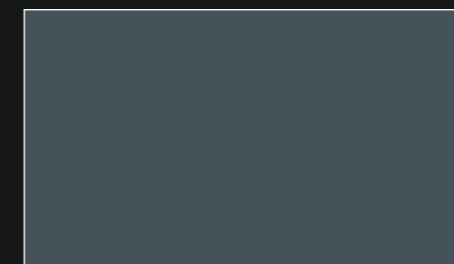

Condor Grey, metallic 5Q

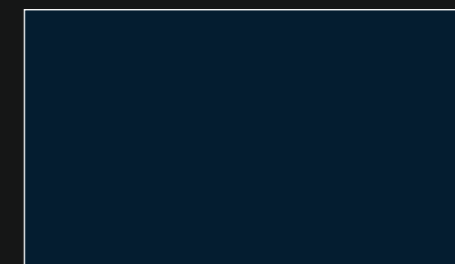

Meteor Grey, pearl effect X5

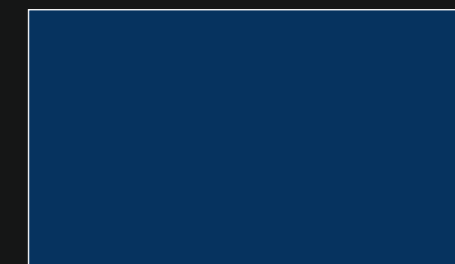

Aruba Blue, pearl effect 09

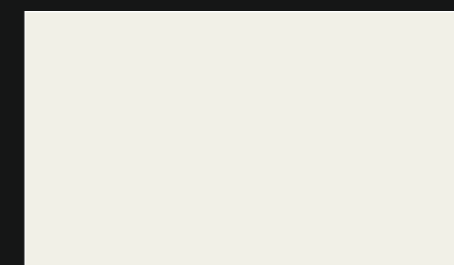

Ibis White T9

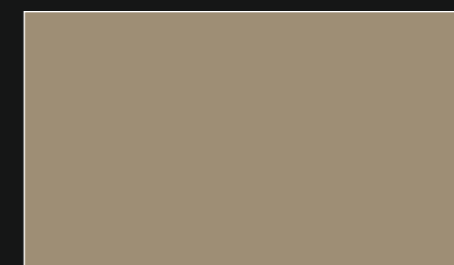

Dakar Beige, metallic 9X

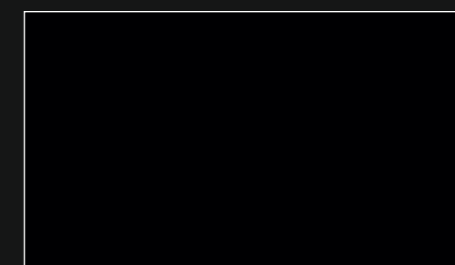

Phantom Black, pearl effect L8

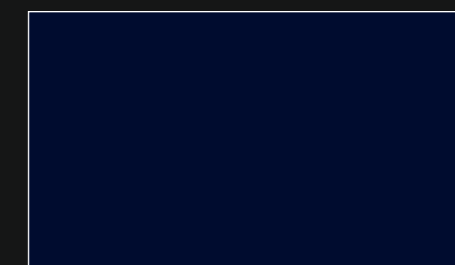

Deep Sea Blue, pearl effect 8A



Audi TT Coupé in Petrol Blue pearl effect, with cast aluminium wheels in 10-spoke design, polished, two-tone. Sports seats in pale grey Fine Nappa leather, extended colour leather package, extended aluminium look in interior.



Audi TT Coupé in Ice Silver metallic with cast aluminium wheels in 7-arm dynamic design. Sports seats in black Alcantara/leather combination, extended leather package, extended aluminium finish in interior.





Audi TT Roadster in Ice Silver metallic with cast aluminium wheels in 7-arm dynamic design.
Sports seats in Impulse leather, chennai brown, extended colour leather package, extended aluminium finish in interior.



Audi TT Roadster in Ice Silver metallic and black hood with cast aluminium wheels in in 5-arm dynamic design.
Sports seats in Fine Nappa leather, magma red, extended colour leather package, extended aluminium finish in interior.



| Model | TT Coupé 1.8 TFSI | TT Coupé 2.0 TFSI | TT Coupé 2.0 TFSI S tronic | TT Coupé 2.0 TFSI quattro S tronic |
|---|--|---|---|--|
| Engine type | 4-cylinder in-line petrol engine with direct fuel injection and exhaust gas turbocharger | 4-cylinder in-line petrol engine with direct fuel injection and exhaust turbocharging | 4-cylinder in-line petrol engine with direct fuel injection and exhaust turbocharging | 4-cylinder in-line petrol engine with direct fuel injection and exhaust gas turbocharger |
| Displacement in cc (valves per cylinder) | 1798 (4) | 1984 (4) | 1984 (4) | 1984 (4) |
| Max. output¹ in kW at rpm | 118/4500–6200 | 147/5100–6000 | 147/5100–6000 | 147/5100–6000 |
| Max. torque in Nm at rpm | 250/1500–4500 | 280/1800–5000 | 280/1800–5000 | 280/1700–5000 |

Power transmission/wheels

| | | | | |
|----------------------|-----------------------------------|-----------------------------------|-----------------------------------|------------------------------------|
| Type of drive | Front-wheel drive | Front-wheel drive | Front-wheel drive | quattro® permanent all-wheel drive |
| Transmission | 6-speed manual transmission | 6-speed manual transmission | 6-speed S tronic | 6-speed S tronic |
| Wheels | Cast aluminium wheels, 7.5 J x 16 | Cast aluminium wheels, 7.5 J x 16 | Cast aluminium wheels, 7.5 J x 16 | Cast aluminium wheels, 7.5 J x 16 |
| Tyres | 225/55 R 16 | 225/55 R 16 | 225/55 R 16 | 225/55 R 16 |

Weights/capacities

| | | | | |
|---|------|------|------|------|
| Unladen weight² in kg | 1240 | 1260 | 1280 | 1360 |
| Gross vehicle weight in kg | 1640 | 1660 | 1680 | 1760 |
| Roof load in kg | 75 | 75 | 75 | 75 |
| Fuel tank capacity in l | 55 | 55 | 55 | 60 |

Performance/consumption³

| | | | | |
|---|---|--|--|-----------------------|
| Top speed in km/h | 226 | 240 | 240 | 238 |
| Acceleration 0–100 km/h in s | 7.2 | 6.6 | 6.4 | 6.2 |
| Fuel grade | Super unleaded 95 RON | SuperPlus unleaded 98 RON ⁴ | SuperPlus unleaded 98 RON ⁴ | Super unleaded 95 RON |
| Fuel consumption⁵ in l/100 km | urban extra-urban combined | 9.0 5.3 6.7 | 10.7 6.0 7.7 | 10.6 6.0 7.7 |
| CO₂-emissions⁵ in g/km | urban extra-urban combined | 209 124 155 | 255 143 183 | 252 143 183 |
| Emissions standard | EU5 | EU4 | EU4 | EU5 |

Explanatory notes ¹ to ⁵ on Page 98.

| Model | TT Coupé 3.2 quattro | TT Coupé 3.2 quattro S tronic | TT Coupé 2.0 TDI quattro |
|---|---|---|---|
| Engine type | V6 petrol engine with intake manifold injection | V6 petrol engine with intake manifold injection | 4-cylinder in-line diesel engine with TDI® direct injection |
| Displacement in cc (valves per cylinder) | 3189 (4) | 3189 (4) | 1968 (4) |
| Max. output¹ in kW at rpm | 184/6300 | 184/6300 | 125/4200 |
| Max. torque in Nm at rpm | 320/2500–3000 | 320/2500–3000 | 350/1750–2500 |

Power transmission/wheels

| | | | |
|----------------------|---|---|------------------------------------|
| Type of drive | quattro® permanent all-wheel drive | quattro® permanent all-wheel drive | quattro® permanent all-wheel drive |
| Transmission | 6-speed manual transmission | 6-speed S tronic | 6-speed manual transmission |
| Wheels | Lightweight forged aluminium wheels, 8.5 J x 17 | Lightweight forged aluminium wheels, 8.5 J x 17 | Cast aluminium wheels, 7.5 J x 16 |
| Tyres | 245/45 R 17 | 245/45 R 17 | 225/55 R 16 |

Weights/capacities

| | | | |
|---|------|------|------|
| Unladen weight² in kg | 1410 | 1430 | 1370 |
| Gross vehicle weight in kg | 1810 | 1830 | 1770 |
| Roof load in kg | 75 | 75 | 75 |
| Fuel tank capacity in l | 60 | 60 | 60 |

Performance/consumption³

| | | | |
|---|---|--|----------------------------------|
| Top speed in km/h | 250 (regulated) | 250 (regulated) | 226 |
| Acceleration 0–100 km/h in s | 5.9 | 5.7 | 7.5 |
| Fuel grade | SuperPlus unleaded 98 RON ⁴ | SuperPlus unleaded 98 RON ⁴ | Diesel in accordance with EN 590 |
| Fuel consumption⁵ in l/100 km | urban extra-urban combined | 14.7 7.8 10.3 | 12.9 7.3 9.4 |
| CO₂-emissions⁵ in g/km | urban extra-urban combined | 352 187 247 | 308 174 224 |
| Emissions standard | EU4 | EU4 | EU5 |

| Model | TT Roadster 1.8 TFSI | TT Roadster 2.0 TFSI | TT Roadster 2.0 TFSI S tronic | TT Roadster 2.0 TFSI quattro S tronic |
|---|--|---|---|--|
| Engine type | 4-cylinder in-line petrol engine with direct fuel injection and exhaust gas turbocharger | 4-cylinder in-line petrol engine with direct fuel injection and exhaust turbocharging | 4-cylinder in-line petrol engine with direct fuel injection and exhaust turbocharging | 4-cylinder in-line petrol engine with direct fuel injection and exhaust gas turbocharger |
| Displacement in cc (valves per cylinder) | 1798 (4) | 1984 (4) | 1984 (4) | 1984 (4) |
| Max. output¹ in kW at rpm | 118/4500–6200 | 147/5100–6000 | 147/5100–6000 | 147/5100–6000 |
| Max. torque in Nm at rpm | 250/1500–4500 | 280/1800–5000 | 280/1800–5000 | 280/1700–5000 |

Power transmission/wheels

| | | | | |
|----------------------|-----------------------------------|-----------------------------------|-----------------------------------|------------------------------------|
| Type of drive | Front-wheel drive | Front-wheel drive | Front-wheel drive | quattro® permanent all-wheel drive |
| Transmission | 6-speed manual transmission | 6-speed manual transmission | 6-speed S tronic | 6-speed S tronic |
| Wheels | Cast aluminium wheels, 7.5 J x 16 | Cast aluminium wheels, 7.5 J x 16 | Cast aluminium wheels, 7.5 J x 16 | Cast aluminium wheels, 7.5 J x 16 |
| Tyres | 225/55 R 16 | 225/55 R 16 | 225/55 R 16 | 225/55 R 16 |

Weights/capacities

| | | | | |
|---|------|------|------|------|
| Unladen weight² in kg | 1285 | 1295 | 1315 | 1405 |
| Gross vehicle weight in kg | 1605 | 1615 | 1635 | 1725 |
| Fuel tank capacity in l | 55 | 55 | 55 | 60 |

Performance/consumption³

| | | | | |
|---|-----------------------|--|--|-----------------------|
| Top speed in km/h | 223 | 237 | 237 | 235 |
| Acceleration 0–100 km/h in s | 7.4 | 6.7 | 6.5 | 6.4 |
| Fuel grade | Super unleaded 95 RON | SuperPlus unleaded 98 RON ⁴ | SuperPlus unleaded 98 RON ⁴ | Super unleaded 95 RON |
| Fuel consumption⁵ in l/100 km | | | | |
| | urban | 9.1 | 10.7 | 10.8 |
| | extra-urban | 5.6 | 6.2 | 6.1 |
| | combined | 6.9 | 7.8 | 7.8 |
| CO₂-emissions⁵ in g/km | | | | |
| | urban | 211 | 255 | 257 |
| | extra-urban | 129 | 148 | 145 |
| | combined | 159 | 186 | 181 |
| Emissions standard | EU5 | EU4 | EU4 | EU5 |

Explanatory notes ¹ to ⁵ on Page 98.

| Model | TT Roadster 3.2 quattro | TT Roadster 3.2 quattro S tronic | TT Roadster 2.0 TDI quattro |
|---|---|---|--|
| Engine type | V6 petrol engine with intake manifold injection | V6 petrol engine with intake manifold injection | 4-cylinder in-line diesel engine with TDI direct injection |
| Displacement in cc (valves per cylinder) | 3189 (4) | 3189 (4) | 1968 (4) |
| Max. output¹ in kW at rpm | 184/6300 | 184/6300 | 125/4200 |
| Max. torque in Nm at rpm | 320/2500–3000 | 320/2500–3000 | 350/1750–2500 |

Power transmission/wheels

| | | | |
|----------------------|---|---|------------------------------------|
| Type of drive | quattro® permanent all-wheel drive | quattro® permanent all-wheel drive | quattro® permanent all-wheel drive |
| Transmission | 6-speed manual transmission | 6-speed S tronic | 6-speed manual transmission |
| Wheels | Lightweight forged aluminium wheels, 8.5 J x 17 | Lightweight forged aluminium wheels, 8.5 J x 17 | Cast aluminium wheels, 7.5 J x 16 |
| Tyres | 245/45 R 17 | 245/45 R 17 | 225/55 R 16 |

Weights/capacities

| | | | |
|---|------|------|------|
| Unladen weight² in kg | 1470 | 1490 | 1415 |
| Gross vehicle weight in kg | 1790 | 1810 | 1735 |
| Fuel tank capacity in l | 60 | 60 | 60 |

Performance/consumption³

| | | | |
|---|--|--|----------------------------------|
| Top speed in km/h | 250 (regulated) | 250 (regulated) | 223 |
| Acceleration 0–100 km/h in s | 6.1 | 5.9 | 7.7 |
| Fuel grade | SuperPlus unleaded 98 RON ⁴ | SuperPlus unleaded 98 RON ⁴ | Diesel in accordance with EN 590 |
| Fuel consumption⁵ in l/100 km | | | |
| | urban | 14.8 | 13.0 |
| | extra-urban | 7.8 | 7.4 |
| | combined | 10.4 | 9.5 |
| CO₂-emissions⁵ in g/km | | | |
| | urban | 354 | 310 |
| | extra-urban | 187 | 177 |
| | combined | 250 | 227 |
| Emissions standard | EU4 | EU4 | EU5 |

Audi TT Coupé

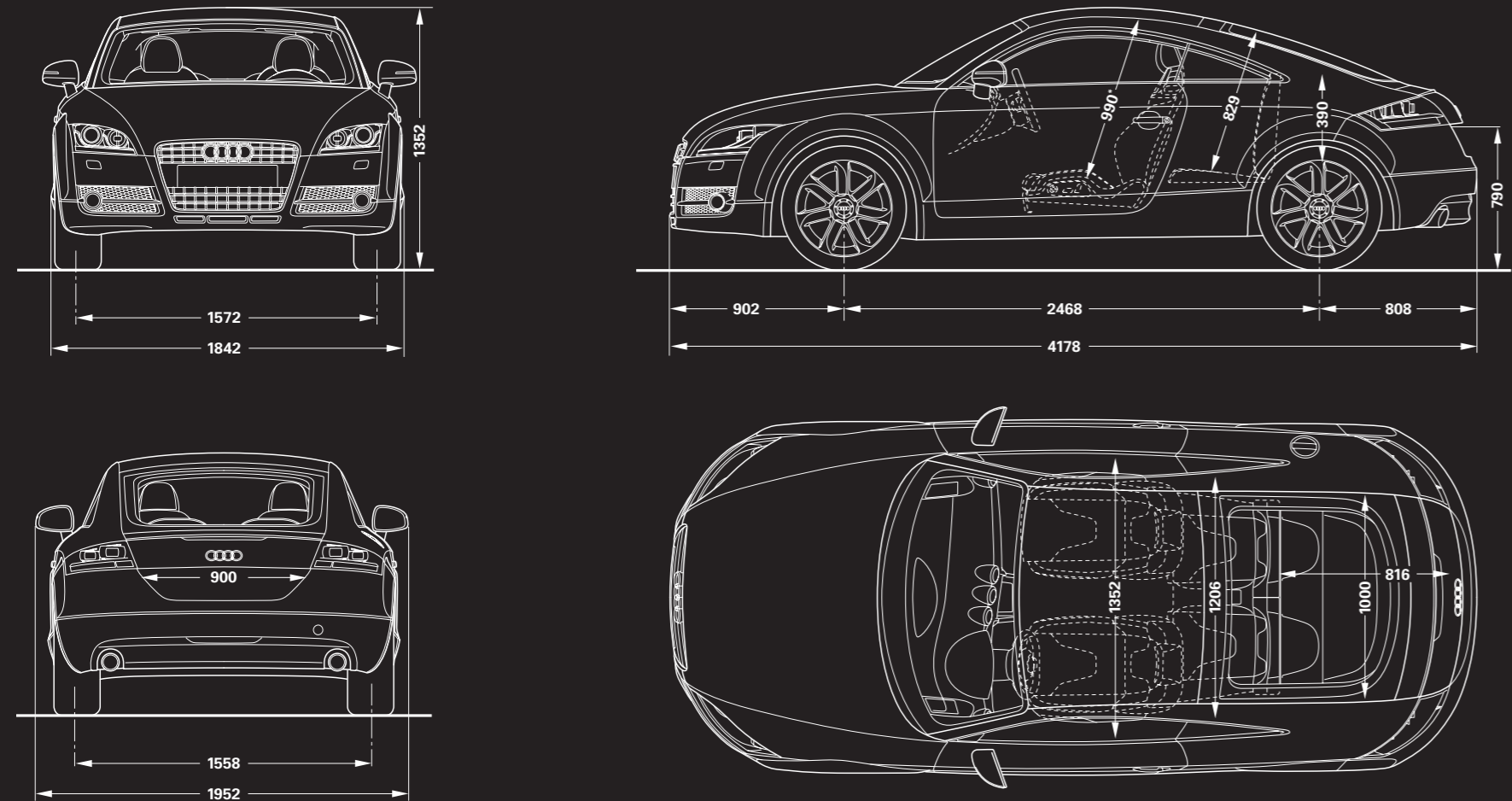

Dimensions in millimetres.

Details of dimensions when vehicle is unladen, without driver.

Luggage compartment capacity 290/700 l (measured by the VDA standard test method using 200 x 100 x 50 mm blocks)

Second value: is with the rear seat folded down and the vehicle loaded up to roof height). Turning circle approx 10.9 m.

*Maximum headroom.

Audi TT Roadster

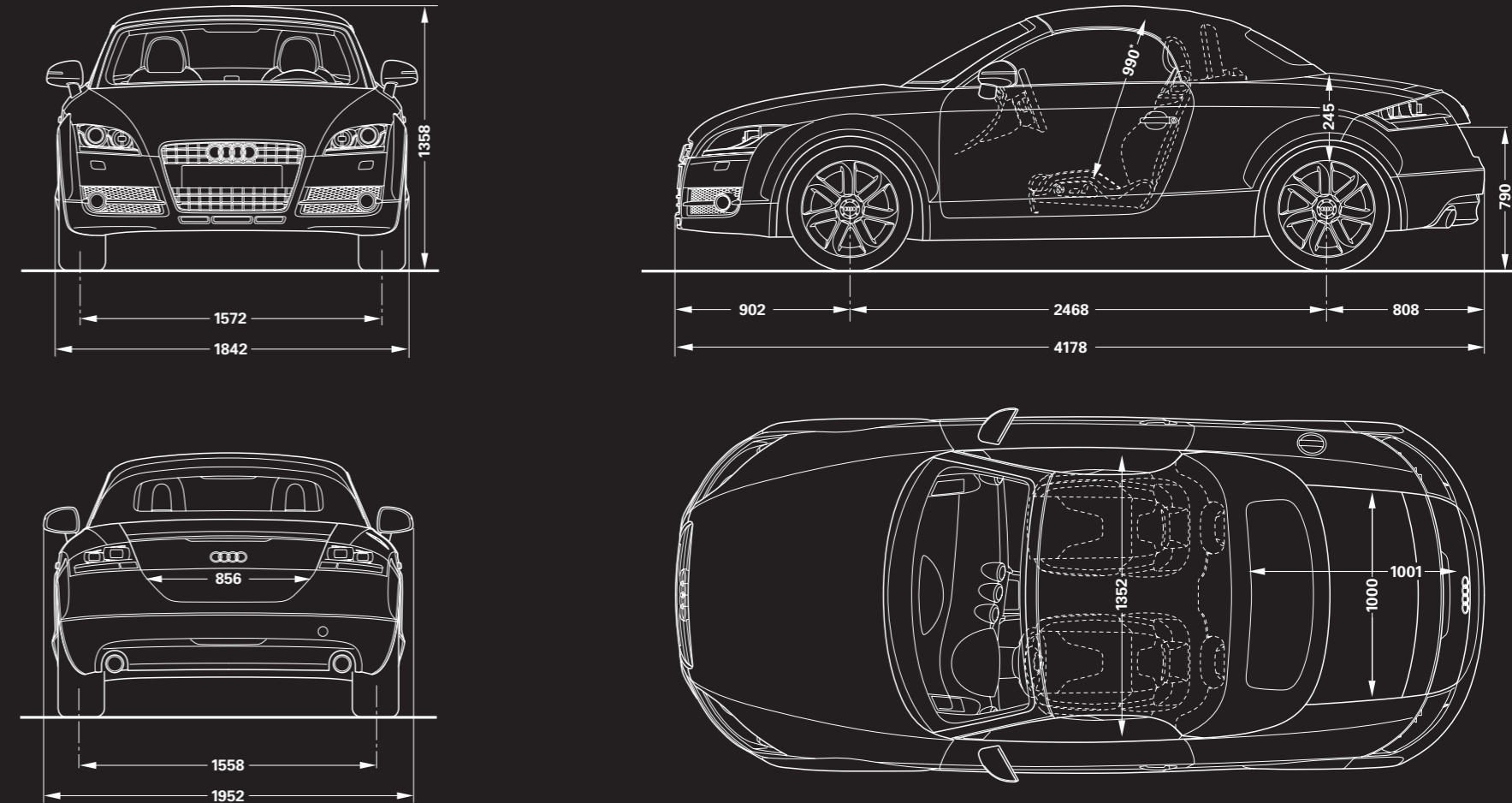

Dimensions in millimetres.

Details of dimensions when vehicle is unladen, without driver.

Luggage compartment capacity 250 l (measured by the VDA standard test method using 200 x 100 x 50 mm blocks)

Turning circle approximately 10.9 m.

*Maximum headroom.

The models and equipment versions illustrated and described in this brochure and some services listed are not available in all countries. Some of the cars illustrated are equipped with optional equipment for which an extra charge is made. Details concerning the delivery specifications, appearance, performance, dimensions and weights, fuel consumption and running costs of the vehicle were correct to the best of our knowledge at the time of going to press. There may be some variations between the Australian vehicle specifications and those manufactured for other markets. Please speak to your Audi Dealer should you have any questions. Deviations from the colours and shapes shown in the illustrations may occur. No liability is accepted for errors and printing errors. The right to introduce modifications is reserved. Not to be reproduced, including in part, without the written approval of Audi AG.