



Q7

V12 TDI quattro

Vorsprung durch Technik 



100 years
Vorsprung durch Technik

Shaped by a century of success: in every one of our vehicles you can feel the beating heart of Audi. Convince yourself of our passion for technology, design and efficiency. And enjoy your own Vorsprung durch Technik in your new Audi Q7 V12 TDI quattro.

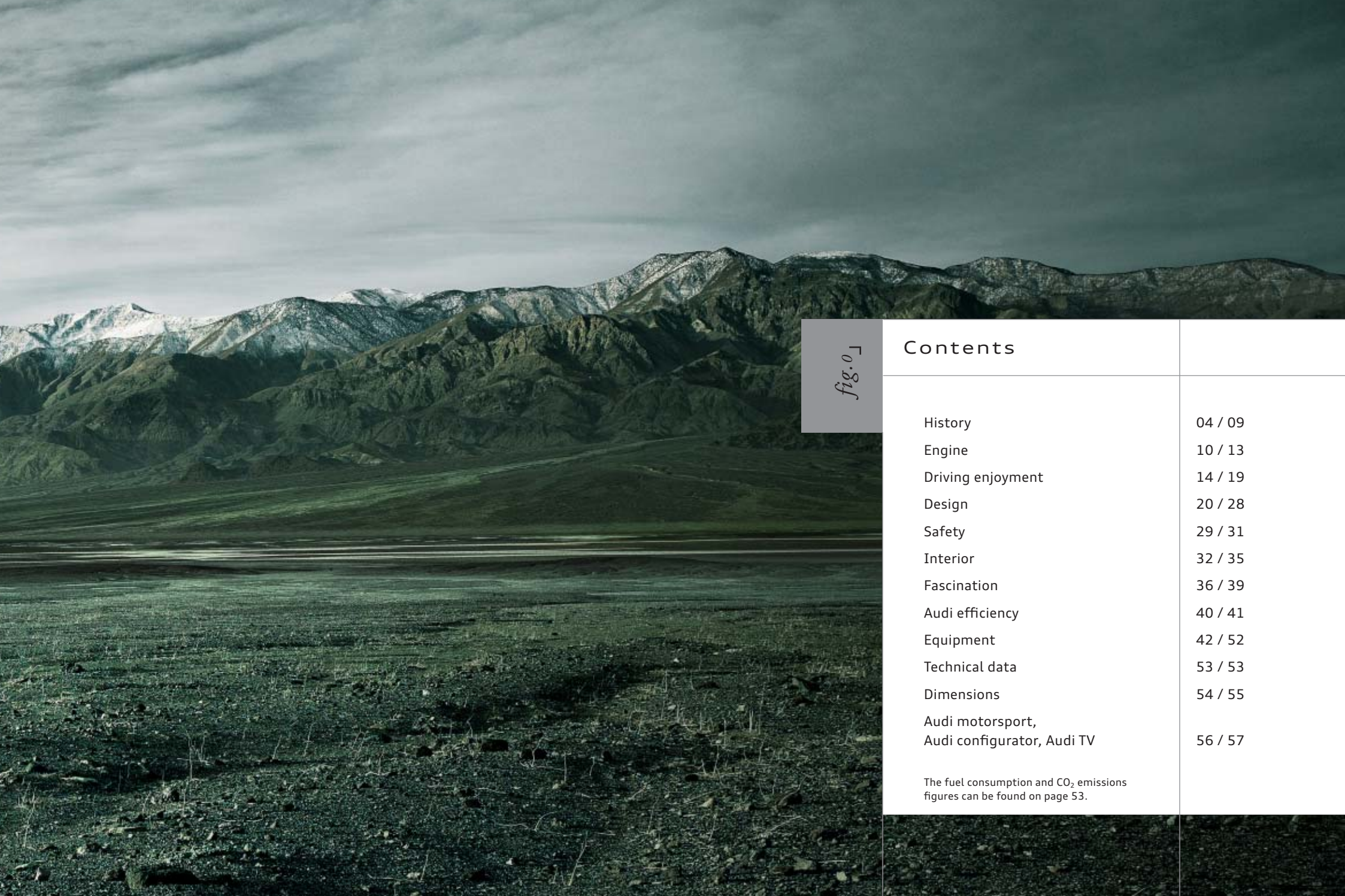

fig. 0

Contents

History	04 / 09
Engine	10 / 13
Driving enjoyment	14 / 19
Design	20 / 28
Safety	29 / 31
Interior	32 / 35
Fascination	36 / 39
Audi efficiency	40 / 41
Equipment	42 / 52
Technical data	53 / 53
Dimensions	54 / 55
Audi motorsport, Audi configurator, Audi TV	56 / 57

The fuel consumption and CO₂ emissions figures can be found on page 53.



fig.1」

Law of nature **no. 1**

All organisms descend from common ancestors.





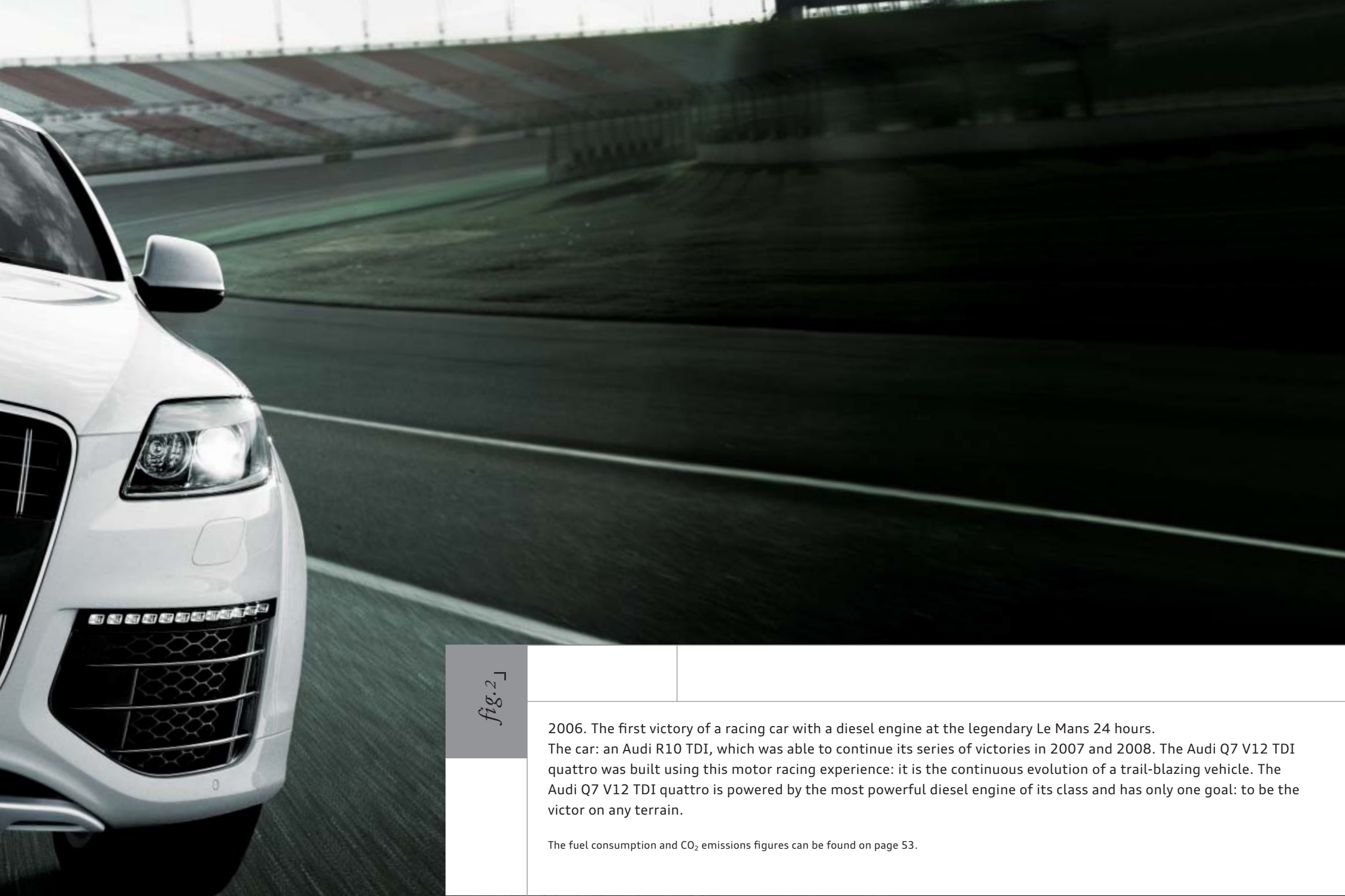

fig. 2

2006. The first victory of a racing car with a diesel engine at the legendary Le Mans 24 hours. The car: an Audi R10 TDI, which was able to continue its series of victories in 2007 and 2008. The Audi Q7 V12 TDI quattro was built using this motor racing experience: it is the continuous evolution of a trail-blazing vehicle. The Audi Q7 V12 TDI quattro is powered by the most powerful diesel engine of its class and has only one goal: to be the victor on any terrain.

The fuel consumption and CO₂ emissions figures can be found on page 53.

fig.3-7」





Law of nature **no. 2****Strong species always continue to evolve.**

The wealth of experience gained in the world of motorsport has been put to use to develop the heart of the Audi Q7 V12 TDI quattro: the most powerful diesel engine of its class. Twelve powerful cylinders work on getting you to your destination of choice. The efficient common rail diesel

technology obtains an impressive amount of power out of every drop of fuel. 6.0 litre displacement. 368 kW. 1,000 Nm of torque at 1,750 to 3,250 rpm. A combination that accelerates you from 0 to 100 km/h in just 5.5 seconds. One press on the accelerator pedal and you will immediately feel its power.

The fuel consumption and CO₂ emissions figures can be found on page 53.



Audi introduced the TDI principle into its series production operations back in 1989 and has continued to optimise it ever since. This technical expertise has culminated in the development of the V12 TDI, the most powerful Audi diesel engine so far.

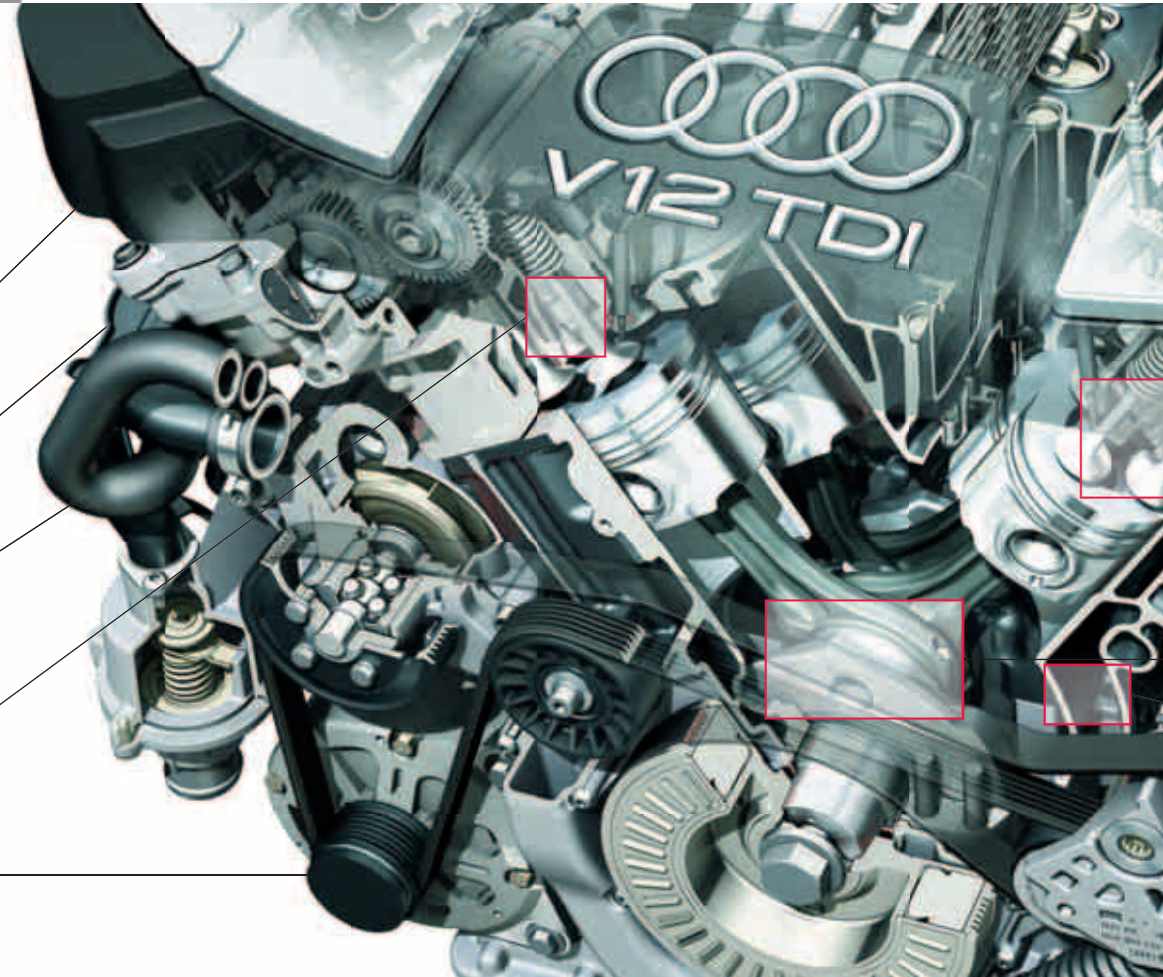

→ The first V12 diesel engine in the world in a series production model. Thus begins a new chapter in the history of the diesel engine. With the 6-litre TDI engine, Audi is once again demonstrating its “Vorsprung durch Technik”.

→ Six litre displacement – more than you have ever had before in an Audi Q7. That creates space for power.

→ 368 kW accelerate the Audi Q7 V12 TDI quattro from 0 to 100 km/h in just 5.5 seconds.

→ Piezo injectors inject the fuel into the combustion chamber at high pressure (up to 2,000 bar). In doing so the fuel is finely atomised, which results in better combustion.

→ You can drive the Audi Q7 V12 TDI quattro up to a top speed of 250 km/h – after which the electronic regulation function comes into action.

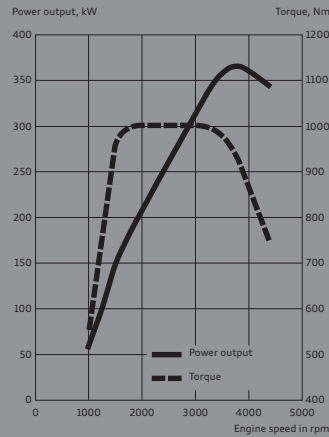

The Audi Q7 V12 TDI quattro reaches its maximum torque of 1,000 Nm at a mere 1,750 rpm and keeps it stable up to 3,250 rpm. Thus excellent performance is at your disposal from an early stage and over a wide range. The engine moves the high-performance SUV with overwhelming supremacy and equanimity, without losing its agility.

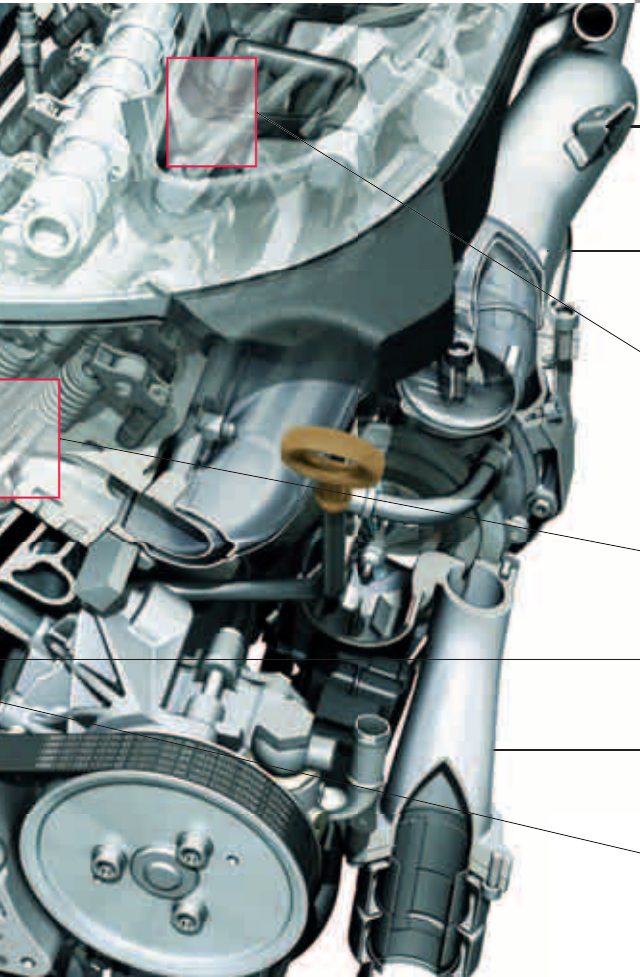

So much power – with comparatively low consumption. The Audi Q7 V12 TDI quattro consumes 11.3 litres of fuel per 100 km.

Concentrated energy: with a length of 684 mm, the diesel engine is extremely compact – an important precondition for integration into a standard production vehicle.

The V12 engine has a cylinder centre to centre distance of 90 mm. Its cylinder angle is just 60° – consequently virtually no vibration-inducing free inertia forces or moments of inertia occur. This results in superb smooth-running performance.

The number of injection processes per work cycle can be exactly adjusted by means of the piezo injectors – up to five processes. Other injection processes are also possible in addition to the main injection. The pilot injection processes temper the acoustic harshness of the combustion process, which is particularly audible at low loads.

The crankshaft is made from a chromium molybdenum steel alloy, the pistons from aluminium.

The maintenance-free chain drive is situated on the rear side of the engine to save space.

The crankcase is made of a high-tech material. It is manufactured using a patented casting process and has remarkable advantages: it is more rigid, more resistance to fatigue and lighter than comparable materials.

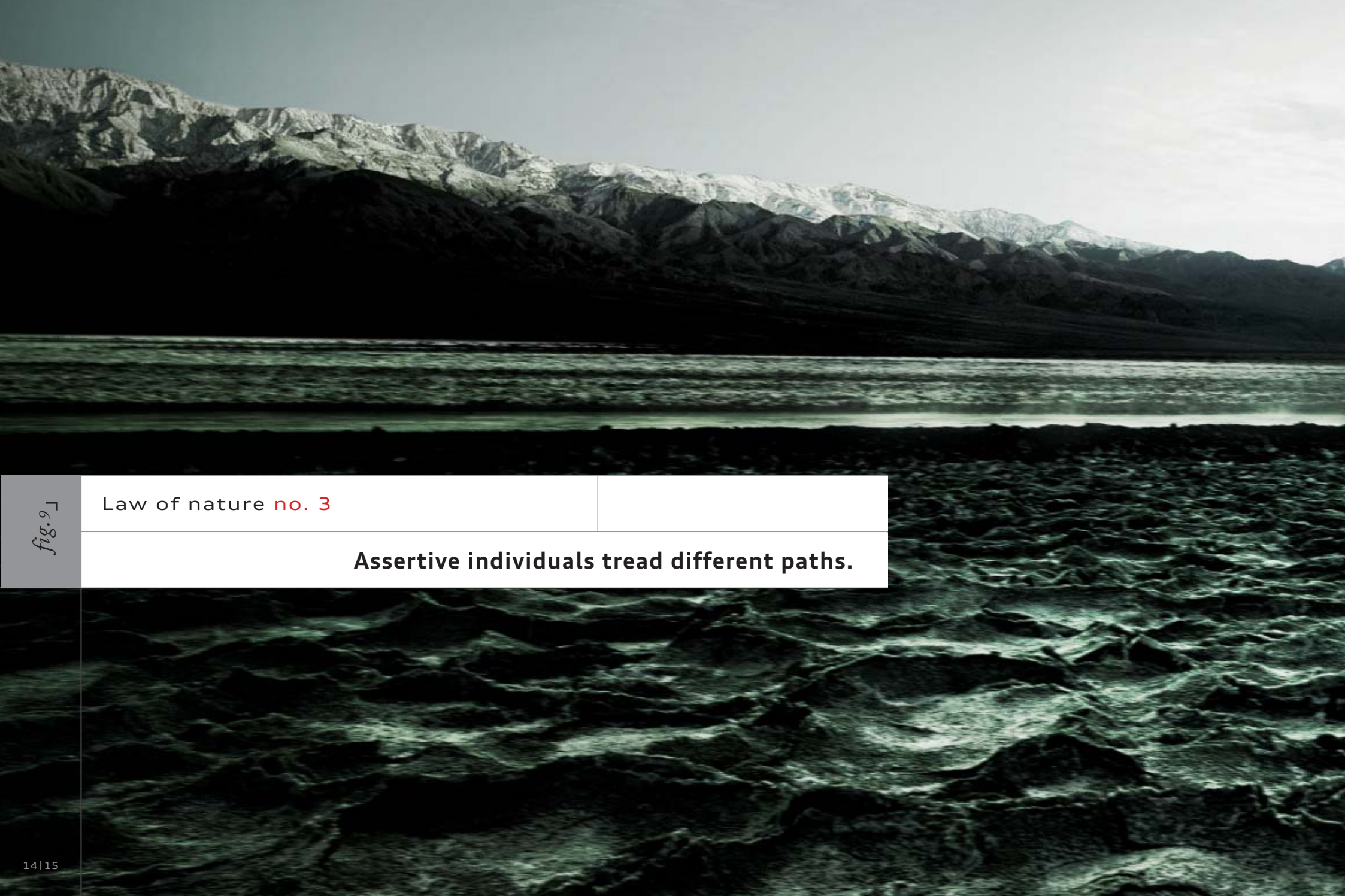

fig. 9

Law of nature **no. 3**

Assertive individuals tread different paths.





fig. 10」

Anyone can drive on normal roads. But it is only when you venture along unknown paths that personal strengths are put to use. And in the case of the Audi Q7 V12 TDI quattro, this is the permanent all-wheel drive. quattro® distributes the driving force asymmetrically and dynamically to all wheels as required. This provides you with excellent traction, both on and off the road – and cornering will suddenly feel much sportier.







fig. 11-15

A long serpentine road. A scarcely frequented forest road. A mountainous gravel track. Three demanding routes – all with the same great driving feeling. Thanks to the standard adaptive air suspension, you can choose between sporty and comfortable suspension settings, just as you wish. Combined with the long wheelbase and the low centre of gravity of the Audi Q7 V12 TDI quattro, this will give you tremendous control and extremely precise handling – even on challenging roads.



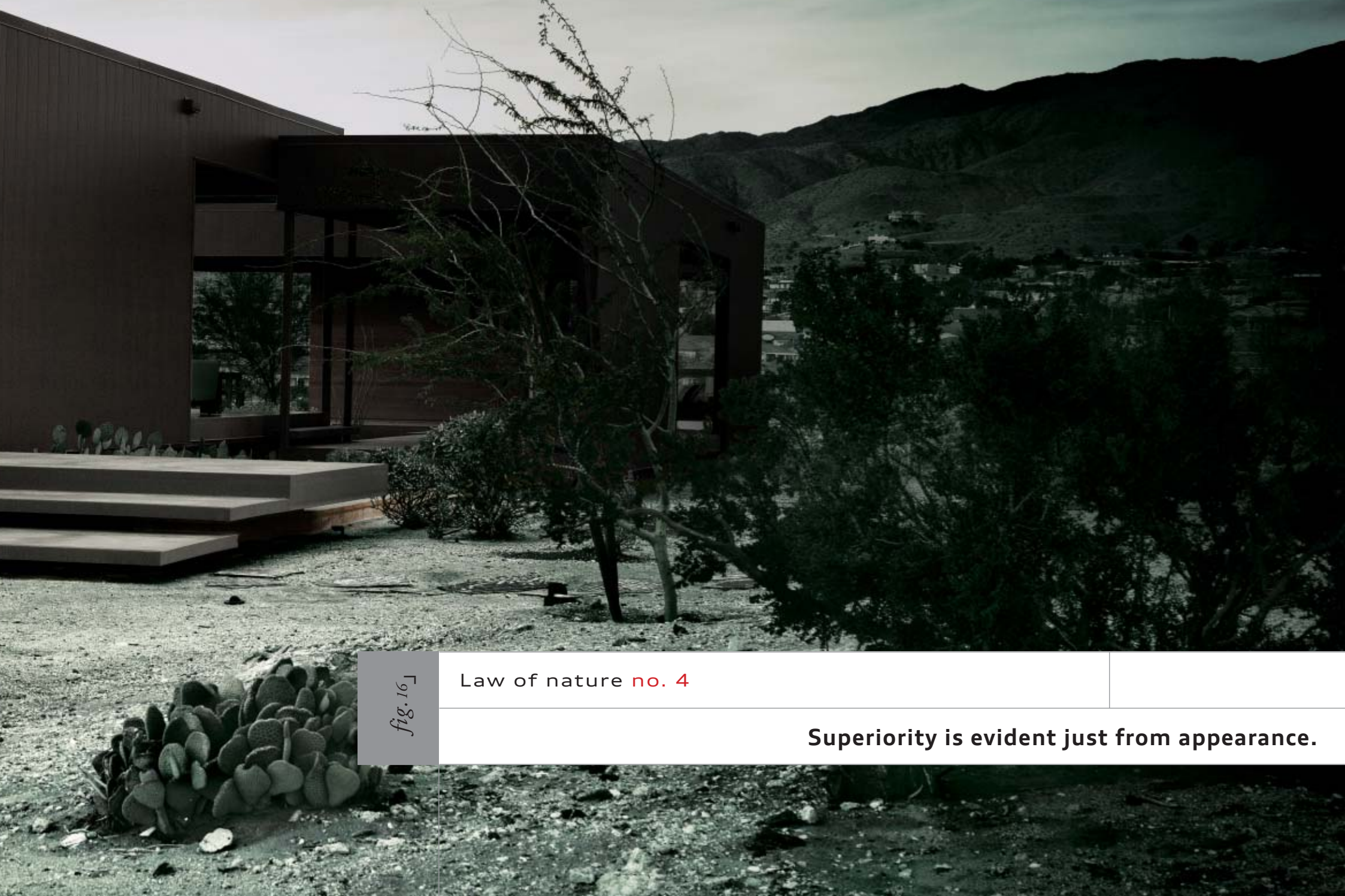

fig. 16

Law of nature **no. 4**

Superiority is evident just from appearance.





fig. 17-19」

Strength. Sovereignty. Pride. Right from first sight, the new Audi Q7 V12 TDI quattro lets you know what it's capable of. The wheel arch extensions give it a dominant and powerful presence. The Xenon plus headlights, in combination with the LED daytime running lights, each of which

consists of twelve LED lamps in the bumper, give the front section an unmistakable appearance. At the rear, special features include oval tailpipes, LED rear lights and a specially designed bumper with stainless steel underbody protection.





fig. 20-21

The chromed singleframe radiator grille gleams invitingly in the sunlight. The powerful standard ceramic brakes are visible through the optional 21-inch wheel rims. Large, shiny black air inlets in the bumpers ensure the high performance power unit gets the necessary ventilation.





fig. 22

Powerful lines and a distinctive face prepare you for exceptional driving performance. An inspired synthesis of dynamics and superior quality – rounded off with intelligent, attractive details. Exterior mirrors and roof rails in matt aluminium testify to individuality, whilst the front and rear stainless steel underbody protection sets a clearly visible accent.





fig. 24

Sudden obstacles may surprise you – but you can conquer them confidently. Behind the large wheels is a mighty braking system with 20-inch ventilated discs made of carbon-fibre reinforced ceramic. The discs are light in weight, yet are prone to less wear and deliver excellent

performance, even with heavy use. The braking system is visually impressive, too: the brake callipers are painted in titanium grey and bear the “Audi ceramic” logo.

fig. 23

Law of nature **no. 5**

Adaptability provides more safety on any terrain.

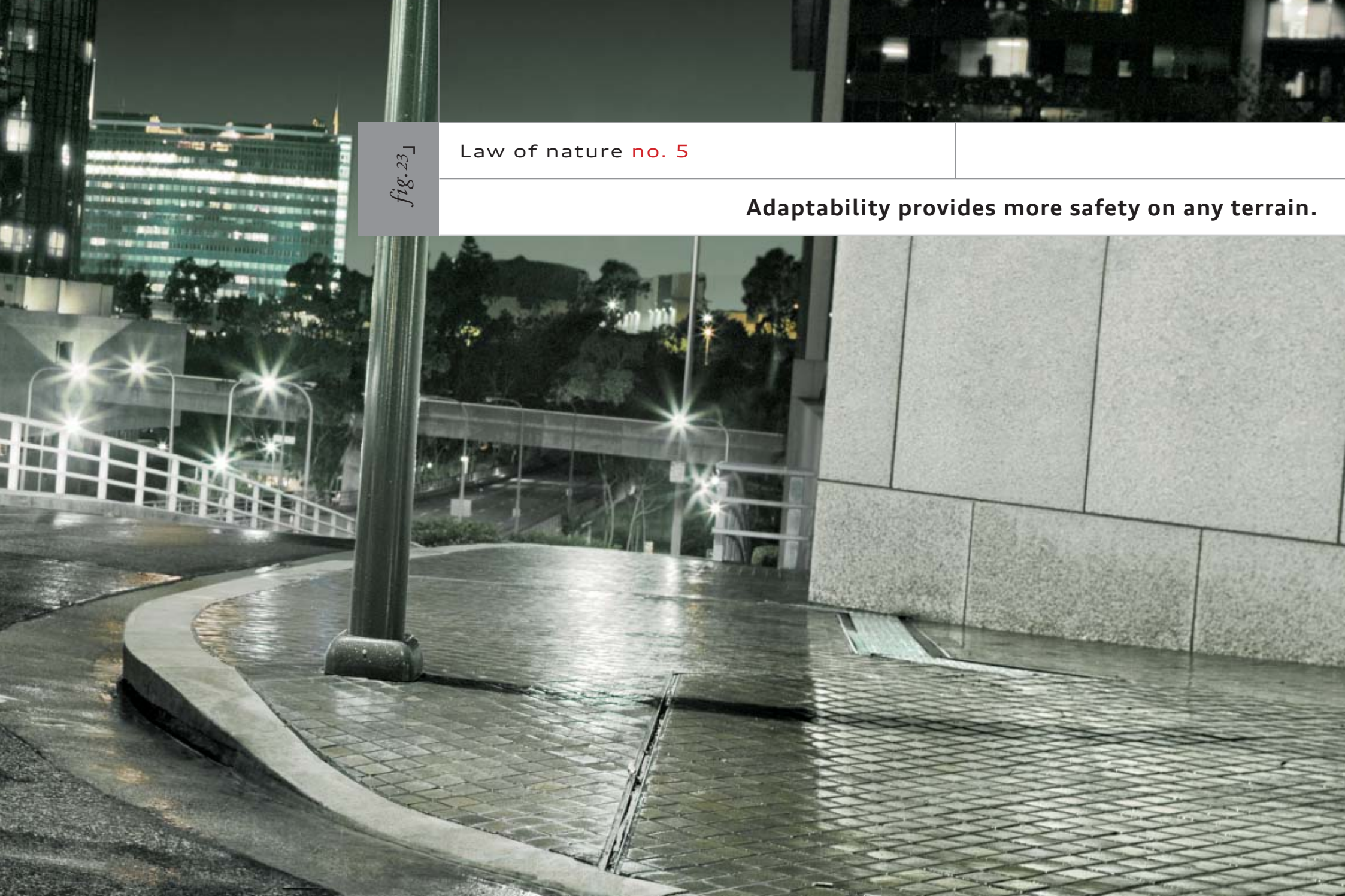





fig. 25

A glance into the cockpit of the Audi Q7 V12 TDI quattro reveals clearly laid out instruments that enable you to assess all situations quickly, thereby ensuring you can concentrate on your driving. The screen of the standard MMI navigation plus is positioned high in the centre console and displays a host of important information such as navigation data, the list of radio stations or the current CD track. The multifunction leather sports steering wheel in 3-spoke design is equipped with chrome-look paddle switches: one more detail that underlines the sportiness of the vehicle.





fig. 26-27

A sporty atmosphere reigns in the interior – and yet it invites you to lean back and relax. The standard electrically adjustable sports seats are covered in Verano leather or, upon request, in two-tone Fine Nappa leather. They hold you well, even on challenging roads. Carbon inlays lend a special look to the centre console and the dashboard, likewise the aluminium-look pedals. You can equip the Audi Q7 V12 TDI quattro to exactly fit your requirements; for example, with the optional leather package advanced, you can choose to have the dashboard fully covered in leather. You see, the Audi Q7 V12 TDI quattro is a typical Audi – high-quality, sporty and perfectly tailored to your requirements.



fig. 28」

The Audi Q7 V12 TDI quattro. An intelligent, sporty evolution. A demonstration of power and efficiency. It obeys only the laws of nature. And you.



Law of nature no. 6

There are always new challenges waiting at the top.





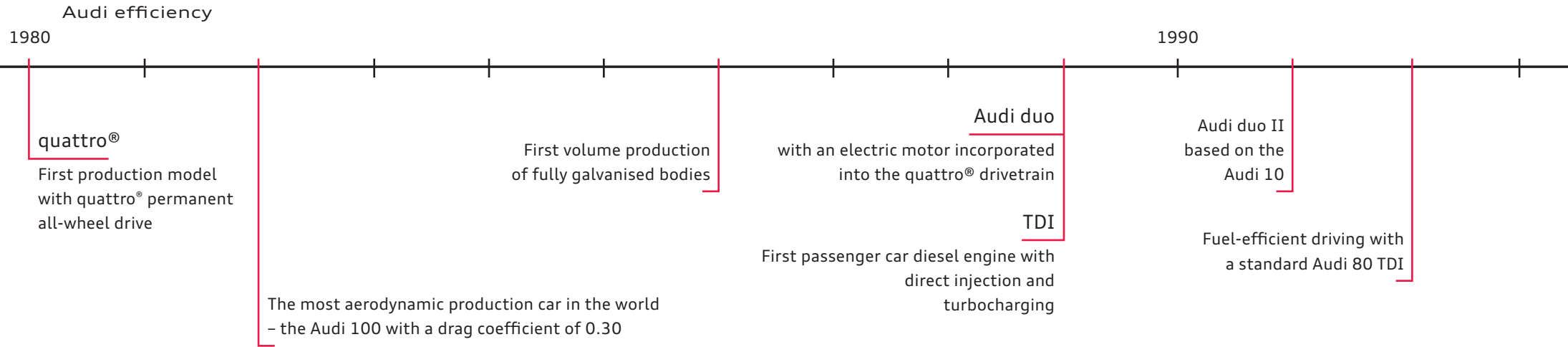

Efficiency: standard in every Audi.

Vorsprung durch Technik is the claim to which the Audi brand is committed. Not just on the subject of sportiness. But also as regards sustainable mobility. Audi is consistently implementing efficiency measures in a unified concept. As the developer of numerous innovations, we have influenced sustainable automobile construction.

Example of engine technology: in 1989, Audi presented TDI, the first diesel engine for cars with direct injection and turbocharging. Technology which is just as efficient and powerful as FSI® and TFSI® for petrol engines. Today, TDI, FSI and TFSI stand for more power with lower consumption and are used in all Audi series.

Example of Audi Space Frame (ASF): in 1994, Audi brought the A8 onto the market; the world's first standard vehicle with

aluminium body. A revolutionary lightweight construction technique which lowered the weight of the bodyshell by 140 kg in comparison with a conventional steel construction. The fuel consumption with the ASF is therefore just as low as with other innovative combinations of material. Moreover, the aerodynamic design, efficient gear technologies like S tronic, electronic assistance systems and promotion of fuel-saving driving make an important contribution to getting around efficiently.

Each of these innovations demonstrates the Audi know-how – and is our daily motivation to continue in future to harmonise efficiency and sportiness.

2000

ASF

Market launch of the Audi A8 with the revolutionary Audi Space Frame (ASF) aluminium structure

multitronic

in the Audi A6 2.8

Audi A2 - the first mass production vehicle with an aluminium body

Audi A2 1.2 TDI - the world's first four-door three-litre vehicle

S tronic

in the Audi TT 3.2 quattro

TFSI®

in the Audi A4

25 years of quattro®

more than 1.8 million vehicles with quattro® permanent all-wheel drive®

Audi R8

Production sports car with FSI® mid-engine and ASF

Audi duo III

Combining a 90 hp diesel engine with a 26 hp electric motor

FSI®

in the Audi A2 and Audi A4

MMI

the new Audi A8 with ASF, quattro® and Multi Media Interface (MMI)

Audi R10 with 12-cylinder TDI engine wins the legendary Le Mans 24-Hour race

Audi TT with further evolved ASF - use of aluminium and steel in one body



Paints



Night Black

A1



Teak Brown, metallic

4U



Cobalt Blue, metallic

5F



Lava Grey, pearl effect

1R

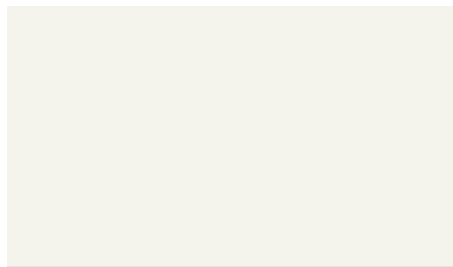

Ibis White

T9



Condor Grey, metallic

5Q



Graphite Grey, metallic

9Q



Garnet Red, pearl effect

9C

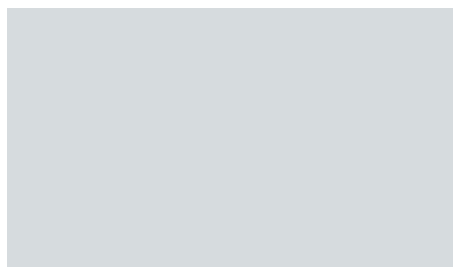

Ice Silver, metallic

P5

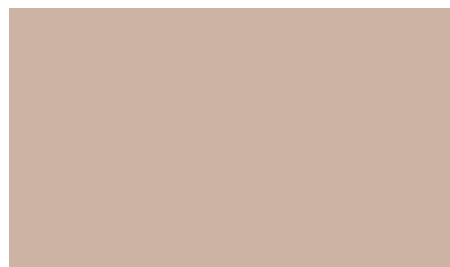

Bahia Beige, metallic

6L



Orca Black, metallic

2T



Mugello Blue, pearl effect

5W

Please find out from your local Audi partner which equipment is standard and what optional equipment is available in your country.

Leather upholstery and trim for sports seats¹

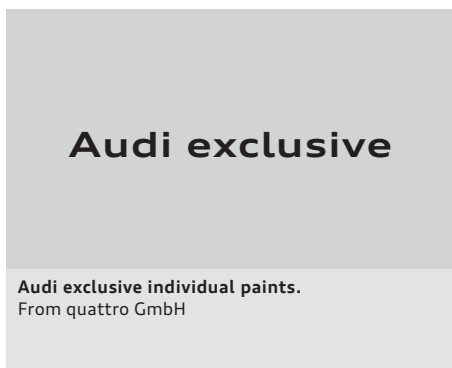
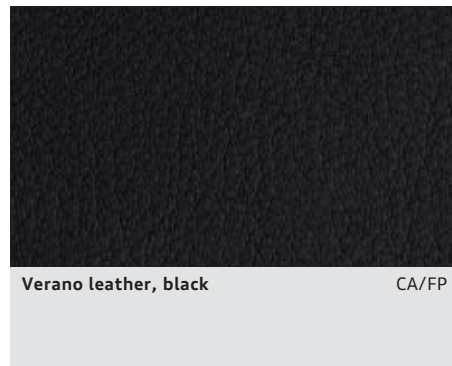
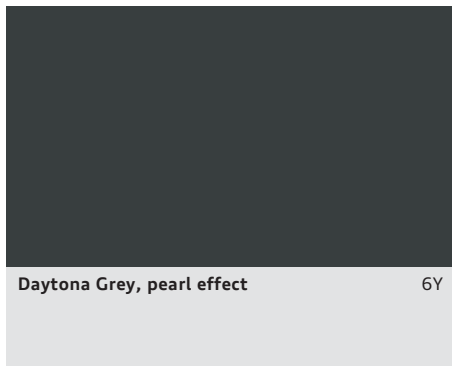

¹Standard front seats in Verano leather are also available upon request. For more information please contact your Audi Partner.

Inlays



Carbon

5TU



Olive ash beige

5MQ

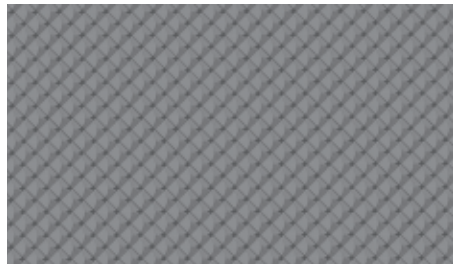

Aluminium Trigon

5TE



Tamo ash dark brown

5TA



Walnut natural

5TS

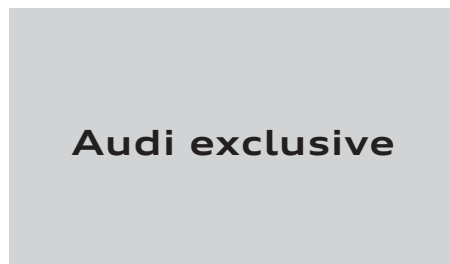

Audi exclusive

Audi exclusive inlays.
From quattro GmbH

Headlining in cloth



Black cloth

Headlining in Alcantara



Alcantara, pale grey



Alcantara, linen beige

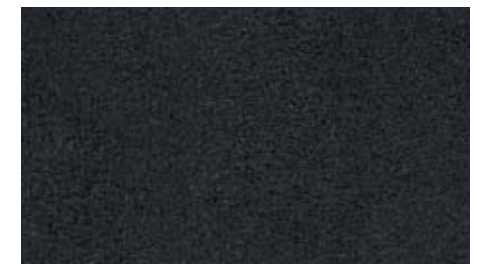

Audi exclusive Alcantara, black.
From quattro GmbH

Please find out from your local Audi partner which equipment is standard and what optional equipment is available in your country.

Audi exclusive wheels/tyres.
From quattro GmbH



Cast aluminium wheels,
10-spoke design,
size 10 J x 20 with 295/40 R 20 tyres



Cast aluminium wheels,
20-spoke design,
two-piece, size 10 J x 20 with 295/40 R 20 tyres



Forged aluminium wheels,
7 double-spoke design,
polished, two-tone, size 10 J x 21
with 295/35 R 21 tyres



Cast aluminium winter wheels,
10-spoke design, size 10 J x 20 with 275/45 R 20
tyres, can be fitted with snow chains, permissible
top speed 240 km/h



Cast aluminium wheels,
5-segment spoke design¹,
size 10 J x 21 with 295/35 R 21 tyres



Forged aluminium wheels,
7 double-spoke design,
high-gloss polished, single-colour,
size 10 J x 21 with 295/35 R 21 tyres

¹Optionally also in titanium look.

Equipment

Equipment packages/design packages

Leather plus design package with front sports seats, front seats electrically adjustable, Verano leather seat covers, comfort centre armrest in leather and door trim in Alcantara, inlays in Carbon, optionally in Walnut natural, Olive ash beige, Tamo ash dark brown or Aluminium Trigon, aluminium-look vent surrounds, footwell trim and floor mats in Velour carpet, optionally in Fresco carpet (colour-matched to the interior)

Leather plus design package with standard seats, front seats electrically adjustable, Verano leather seat covers, comfort centre armrest in leather and door trim in Alcantara, inlays in Carbon, optionally in Walnut natural, Olive ash beige, Tamo ash dark brown or Aluminium Trigon, aluminium-look vent surrounds, footwell trim and floor mats in Velour carpet, optionally in Fresco carpet (colour-matched to the interior)

Sport design package with front sports seats, front seats electrically adjustable, seat covers in Alcantara/Leather combination, comfort centre armrest in leather and door trim in Alcantara, inlays in Carbon, optionally in Walnut natural, Olive ash beige, Tamo ash dark brown or Aluminium Trigon, aluminium-look vent surrounds, footwell trim and floor mats in Velour carpet, optionally in Fresco carpet (colour-matched to the interior)

Audi exclusive line equipment package, black interior (including black attachments), headlining in black cloth, two-colour seat covers (seat side bolsters in black/seat centre sections in choice of sand beige, silver or cognac) in Fine Nappa leather, door trim inserts (to match seat centre sections), inlays in Carbon, optionally in Tamo ash dark brown, Piano finish black or Matt brushed aluminium, floor mats with coloured piping (matching seat centre sections), leather-trimmed comfort centre armrest, multifunction leather sports steering wheel in 3-spoke design with gearshift function and coloured seam (to match seat centre sections, optional multifunction leather steering wheel in 4-spoke design with coloured seam (to match seat centre sections), side bolsters, head restraints, steering wheel rim and gear lever gaiter with coloured seam (to match seat centre sections), Audi exclusive door sill trims

Audi exclusive Leather design package with standard seats, Fine Nappa leather seat covers, footwell trim/floor mats in Velour carpet, comfort centre armrest, aluminium-look vent surrounds. From quattro GmbH

Audi exclusive Leather design package with sports seats, Fine Nappa leather seat covers, footwell trim/floor mats in Velour carpet, comfort centre armrest, aluminium-look vent surrounds. From quattro GmbH

Audi exclusive Alcantara/Leather black design package with sports seats, seat covers in Alcantara/Leather combination (coloured Alcantara, black Leather), footwell trim/floor mats in Velour carpet, comfort centre armrest and aluminium-look vent surrounds. From quattro GmbH

Audi exclusive Leather design package with climate-controlled comfort seats, Valcona leather seat covers, footwell trim/floor mats in Velour carpet, comfort centre armrest, aluminium-look vent surrounds. From quattro GmbH

Audi exclusive Leather plus design package with standard seats, Fine Nappa leather seat covers, including leather-covered seat backrests, door pull handles and door armrests, comfort centre armrest. Footwell trim/floor mats in Velour carpet and aluminium-look vent surrounds. From quattro GmbH

Audi exclusive Leather plus design package with sports seats, Fine Nappa leather seat covers, including leather-covered seat backrests, door pull handles and door armrests, comfort centre armrest. Footwell trim/floor mats in Velour carpet and aluminium-look vent surrounds. From quattro GmbH

Audi exclusive Leather plus design package with climate-controlled comfort seats, seat covers in Valcona leather, including leather-covered seat backrests, door pull handles and door armrests, comfort centre armrest, footwell trim/floor mats in Velour carpet, aluminium-look vent surrounds. From quattro GmbH

Leather package, front centre console (also rear centre console for 6-seater model), upholstery for door armrests and door pull handles in Fine Nappa leather with decorative seam in the same colour as the trim

Leather package advanced, dashboard, door rails, instrument panel cover, front centre console (also rear centre console for 6-seater model) and upholstery for door armrests and door pull handles in Fine Nappa leather with decorative seams in a contrasting colour; includes headlining in Alcantara with contrasting seams and sun visors in Alcantara as well as manual sunblind at the rear and on the rear side windows. (When combined with Audi exclusive line, the decorative seam in the same colour as the trim)

Audi exclusive colour-coordinated decorative seams, can only be ordered in conjunction with a design package and the leather package advanced. From quattro GmbH

Audi exclusive leather package, front centre console (also rear centre console for 6-seater model) and upholstery for door armrests and door pull handles in Fine Nappa leather with decorative seam. From quattro GmbH

Audi exclusive leather package advanced, dashboard, door rails, instrument panel cover, front centre console (also rear centre console for 6-seater model) and upholstery for door armrests and door pull handles in Audi exclusive leather. Available in chestnut brown, palace blue, saddle brown, havanna brown, jet grey and crimson red; individual choice of colour for seams. From quattro GmbH

Paints

Solid paints

Metallic/pearl effect paints

Audi exclusive individual paints. From quattro GmbH

Exterior equipment

Roof systems, closing systems, glazing, further exterior equipment

Roof systems

Panoramic sunroof, 3-part, extends to the 3rd row of seats, electrical activation to raise and open the front glass section and to raise the rear glass section, tinted glass, adjustable fine-meshed sun shield over the entire glass area, electric at the front and manual at the rear, convenience closing from outside via the central locking; creates a bright atmosphere in the interior to ensure a feeling of open spaciousness; when open, provides a pleasant supply of fresh air during the journey

Closing systems

Anti-theft alarm, including interior monitoring and anti-tow away function using angle of inclination sensor; can be deactivated; horn operates independently of vehicle electrical system; monitors doors, engine and luggage compartments

Fitting for Tracking Assistant, fitting for connecting a tracking assistant that enables the vehicle to be located if stolen

Radio remote control, for the central locking, incorporated into the vehicle key, unlocks and locks the doors, windows, luggage compartment and tank flap at the touch of a button; variable rolling code; a telltale lamp in the key indicates the locking status of the vehicle

Please find out from your local Audi partner which equipment is standard and what optional equipment is available in your country.

Garage door opener (HomeLink), programmable radio remote control, control button integrated into the front of the roof module; can be used to open garage doors and exterior gates; control of safety and lighting systems also possible. For more information, please contact your Audi partner.

Gas struts, two each for the bonnet and tailgate

Tailgate, electrically opening and closing, opening via button on vehicle key, button in the driver's door panel or soft touch button in the tailgate handle recess, closing via button on inside of tailgate, with closing assistance and programmable tailgate opening angle

Comfort key, access and drive authorisation system by means of automatic data exchange between the vehicle and key; the key only needs to be carried with you to open and start the vehicle; engine is started and stopped by means of the engine start/stop button in the centre console; the vehicle is locked from the outside by means of buttons on all door handles

Door handles, exterior, body-coloured, user-friendly bow design

Interior door openers, in aluminium look, central locking activation from inside on the driver's door

Ignition lock, electronic, ignition key features integral chip, automatically stores vehicle service data (mileage, chassis number and much more)

Glazing

Double glazing, front and side windows with laminated safety glass, two windows which are joined together by a plastic film; improves exterior noise insulation and theft protection; available with or without dark tinted windows at rear

Windscreen, made of heat-insulating glass, laminated glass with grey-tinted strip along the top edge. (No tinted strip if Audi lane assist is installed)

Rear window, heated, with timer switch and integral window aerial

Rear window wiper, with automatic wash/wipe function

Dark tinted windows (privacy glazing), dark tinted rear window, rear door windows and rear side windows, with or without double glazing

Windscreen washing system, two speeds, automatic switching, flick-wipe function, automatic wash/wipe, automatic wiping approx. 5 seconds after the last wash/wipe process, includes heated washer nozzles

Heat-insulating glass, green tinted

Further exterior equipment

Trailer towing hitch

mechanical: removable and lockable ball head attachment, 13-pin socket with cover; when removed, the trailer towing hitch can be stored in the spare wheel well; includes trailer stabilisation system via the Electronic Stabilization Programme (ESP)

electrical: electrically swivelling ball head attachment, operated via button in luggage compartment; includes trailer stabilisation system via Electronic Stabilization Programme (ESP); suitable for trailers with either bulb or LED lighting

Exhaust tailpipes, dual-branch design with oval-shaped tailpipe trims

Roof rails, in matt aluminium, one-piece design – no joints, sturdy aerodynamic shape, accentuates the coupé-like roof lines

High-gloss package, exterior window capping trims in matt aluminium, exterior B and C-pillar trim in highly-polished Black

Logo/model name, quattro logo in radiator grille, V12 lettering on the front wings, V12 TDI quattro lettering on the tailgate; model name can also be omitted if required

Singleframe, one-piece decorative trim frame around the radiator grille, chromed, with vertical chrome struts; bright-metal Audi rings in the centre

Bumpers, body-coloured, body-coloured door trim strips, sportily accentuated bumpers and large side air inlets with high-gloss black painted horizontal grille struts; dynamically shaped wheel arch extensions; distinctive extensions to the lower sections of the doors and sills

Underbody protection, front and rear, in stainless steel

Wheels/tyres

Audi exclusive wheels/tyres. From quattro GmbH

Cast aluminium wheels, 10-spoke design, size 10 J x 20 with 295/40 R 20 tyres

Cast aluminium wheels, 20-spoke design, two-part design, size 10 J x 20 with 295/40 R 20 tyres

Cast aluminium wheels, 5-segment-spoke design, size 10 J x 21 with 295/35 R 21 tyres

Cast aluminium wheels, 5-segment-spoke design, titanium look, size 10 J x 21 with 295/35 R 21 tyres

Forged aluminium wheels, 7-double-spoke design, polished, two-tone, size 10 J x 21 with 295/35 R 21 tyres

Forged aluminium wheels, 7-double-spoke design, high-gloss polished, single-colour, size 10 J x 21 with 295/35 R 21 tyres

Cast aluminium winter wheels, 10-spoke design, size 10 J x 20 with 275/45 R 20 tyres, can be fitted with snow chains, permissible top speed 240 km/h

Vehicle tool kit and jack in luggage compartment

Wheel-bolts, anti-theft, can only be loosened using adapter provided

Tyre pressure monitoring system, monitors the set tyre pressure and temperature of the driving wheels whilst driving, also works on factory-fitted winter wheels; air pressures and wheel temperatures can be displayed in the MMI system

Tyre repair kit, with 12 volt compressor and tyre sealant, located under the loading floor cover in the boot; top speed 80 km/h

Equipment

Lights and mirrors

Lights

adaptive light, including Xenon plus: dynamic cornering light via swivelling headlights; the headlights swivel into the approaching corner or bend to provide better illumination; operational between speeds of approx. 10 km/h and 110 km/h.

Brake light, high-mounted third brake light in roof spoiler

Main beam assist, automatically detects the headlights of oncoming traffic, the rear lights of other road users and built-up areas. Depending on the traffic situation, the main beam is automatically switched on or off. The system thereby improves the driver's visibility and ensures a more relaxed drive thanks to the extra comfort and convenience

Footwell lights, front

Luggage compartment lighting

Interior lighting with delayed switch-off and contact switches on all doors

Audi exclusive cardan reading lights, (two) in the rear, for additional illumination (in the area of the 2nd row of seats), cone of light from reading lamps can be manually adjusted. (Cannot be ordered in conjunction with the panoramic roof.) From quattro GmbH

LED rear light, energy-saving LED indicators, tail lights and brake lights, white reversing lights, rear fog lights and - when tailgate is open - rear light function in light band in bumper

Reading lights, two each front and rear, plus one in area of 3rd row of seats; providing optimised illumination

Lighting package, includes door front-end illumination below the exterior mirrors, LED ambient lighting of centre console, illuminated controls for vents in the instrument panel and rear centre console, active door reflectors in the front and rear doors, front and rear LED footwell lighting, entrance lighting at rear and illuminated rear ashtrays and door ambient lighting

Headlight cleaning system, uses water and high pressure – for excellent illumination and improved visibility

Xenon plus, headlights utilising mercury-free gas discharge technology for main and dipped beam, includes headlight cleaning system, LED daytime running lights, each with 12 low-energy LEDs incorporated into the bumper on the left and right-hand sides, automatic, dynamic headlight range control

Mirrors

Exterior mirror housings, matt aluminium look, aspherical on the driver's side, convex on the front-passenger side, electrically adjustable and folding, heated, automatically dimming, with integral LED indicator

Interior mirror, automatically dimming with light/rain sensor, with the aid of a photocell recognises when headlights behind are too bright and dims automatically; can be switched off, with digital compass display if required; this provides a digitised display of the current compass heading; the eight points of the compass (N, NE, E, SE, S, SW, W, NE) are shown in English

Mirror glass, flat on the driver's side

Seats

Seats, seating comfort, seat covers/leather packages

Seats

3rd row of seats, two seats in the rear with folding head restraints and two additional ISOFIX child seat mountings, can be split and folded flat to create a level loading floor, for persons up to 1.60 m in height, with comfort entry feature and fore/aft adjustment for the 2nd row of seats

Climate-controlled comfort seats at front, exclusive seat option with shaped side bolsters and soft-feel design for luxurious comfort; actively ventilated and heated; perforated leather on the ventilated seat areas of the front seats and on the non-ventilated seat areas of the two outer rear seats

Comfort seats in the 2nd row of seats, six seats (when combined with the 3rd row of seats), two comfortable single seats in the 2nd row of seats, can be folded flat to create a level loading floor, with comfort entry function, fore/aft adjustment and large centre console with height-adjustable armrest, storage compartment and two drinks holders. Only in combination with the 3rd row of seats. The car then provides space for a total of six people

Rear seats (2nd row of seats), five or (when combined with the 3rd row of seats) seven seats with backrest angle adjustment and belt height adjustment on the outer seats, rear seat backrest can be split 40:60 or completely, creates a level loading floor, includes load-through facility

Sports seats at front, with shaped side bolsters for better lateral support when cornering; electrical adjustment of front/back position, seat height, seat and backrest angle, with manual thigh support adjustment; includes electrical lumbar support; if required with memory function

Standard seats at front, with electric fore/aft, seat height, seat and backrest angle adjustment

Seating comfort

Comfort centre armrest at front for driver and front passenger, with fold-open storage compartment on the driver's side, a drinks holder at the front on the passenger side as well as an additional drinks holder in the armrest on the passenger side (fold-open), with storage compartment (not if CD changer is fitted)

Head restraints for all seats, manually height adjustable at front, outer rear head restraints folding

Fore/aft adjustment for the 2nd row of seats, manual seat fore/aft adjustment, 80 mm forwards and 20 mm to the rear, to create more legroom or luggage compartment space

Lumbar support, electrical for driver and front-passenger seat, with electric vertical and horizontal adjustment

Memory function, for driver's seat or driver and front-passenger seat, includes electrically adjustable front seats, memory function for seat adjustment, exterior mirrors and steering wheel (with electrical steering column adjustment)

Rear centre armrest, in the rear seat backrest, folding, with two drinks holders

Seat heaters for driver and front-passenger seat and for outer seats of 2nd row if required, heat seat cushions, backrests and on sports or leather seats also the front-seat side bolsters; the heaters can be individually adjusted in several stages; particularly pleasant in the winter.

Please find out from your local Audi partner which equipment is standard and what optional equipment is available in your country.

Seat covers/leather packages

Seat covers in Alcantara/Leather combination for sports seats: head restraints, seat and side bolsters and comfort centre armrest in leather; seat centre sections and door trim in Alcantara. (Can be ordered via the Sport design package)

Seat covers in Verano leather for standard seats: head restraints, seat and side bolsters and seat centre sections in Verano leather, comfort centre armrest in leather and door trim in Alcantara

Seat covers in Verano leather for sports seats: head restraints, seat and side bolsters and seat centre sections in Verano leather, comfort centre armrest in leather and door trim in Alcantara

Interior equipment

Decorative elements, climate control, luggage securing and storage systems, further interior equipment

Decorative elements

Inlays, in Carbon

Inlays, in Walnut brown, Olive ash beige, Tamo ash dark brown or Aluminium Trigon in door trim and large-area inlay for the centre console and the dashboard; includes an aluminium insert in the door trim for wood inlays. (Can be ordered via design packages)

Audi exclusive inlays in Poplar wood saffron, Fine grain maple wood copper, Piano finish black, Fine grain ash nougat, Fine grain myrtle nutmeg or Oak wood sepia. From quattro GmbH

Door sill trims with aluminium inlay

Climate control

Deluxe automatic air conditioner with sunlight-dependent control, separate temperature and air distribution for driver and front passenger, indirect ventilation, air conditioning of the rear compartment via air vents in the B-pillars and the rear centre console, automatic air recirculation control using an air quality sensor, rapid defrost button, combined pollution and pollen filter, key-coded settings

Four-zone deluxe automatic air conditioner, in addition to the features of the deluxe automatic air conditioner: separate temperature and air distribution adjustment for the rear left and right-hand sides, air vents in the C-pillar, air conditioning control panel for the rear compartment in the rear centre console, functions for the rear compartment can also be adjusted via the front control panel; includes an additional air conditioning unit in the luggage compartment side trim

Auxiliary heating/ventilation with timer and separate radio remote control with function feedback; provides a pleasant climate in the vehicle, even when the vehicle is stationary; the heater warms up the interior and keeps the windows free from ice, the auxiliary ventilation supplies fresh air and reduces the interior temperature

Luggage securing and storage systems

Storage compartment with rubber mat in the front centre console

Storage compartments, in the front and rear door trims, in the centre console at the front and in the roof module and in the drawer under the front-passenger seat

Storage net in the front of the centre console, on the front-passenger side

Storage package, storage net on the rear of the front-seat backrests, net on the luggage compartment side trim and combined net in luggage compartment

Storage package with fold-away tables, fold-away table on the rear of the front-seat backrests, net on the luggage compartment side trim and combined net in luggage compartment

Load-through facility, creates a level loading floor for transporting long objects, includes rear centre armrest with drinks holders

Cycle rack in the luggage compartment, suitable for transporting up to two cycles with a wheel size of up to 26 inches. (Not in conjunction with Bang & Olufsen Advanced Sound System)

Bottle holders, to store bottles of up to 1.5 litres in the front and rear door trims, four in total

Luggage compartment, large volume, with wide load-through width, luggage compartment release with soft-touch function

Luggage compartment cover, can be pulled out with one hand, removable, with split cover, can be adapted to the backrest angle of the 2nd row of seats

Luggage compartment cover, folding, can be pulled out, removable, folded in the centre, stored in double loading floor, includes fastening adapter and storage bag, additionally supplied

Drinks holders, two in the front centre armrest, two in the rear centre armrest and two in the side panels in the area of the optional 3rd row of seats – when not being used serves as holder for luggage compartment cover

Glove compartment on the front-passenger side, with illumination and air conditioning, opened via switch on the dashboard

Fold-away tables on the rear of the front-seat backrests

Clothes hooks, two in the rear roof area, also one each on the left and right-hand B-pillars

Audi exclusive coolbox, utilising compressor cooling technology, two temperature settings are possible: -6 °C freeze, +6 °C cool; can accommodate four 0.5 litre bottles lying down. From quattro GmbH

Double loading floor, with dirt collecting tray underneath in vehicles without full-size spare wheel; storage compartment behind the 2nd row of seats in vehicles without 3rd row of seats, easy to clean

Rail system with variable lashing points; with securing set, including telescopic rod and fastening strap, for partitioning the luggage compartment and securing objects according to requirements

Ski bag, removable, for the load-through facility, for the practical transportation of long objects, e.g. up to four pairs of skis or two snowboards

Partition grille, for fastening to the vehicle bodywork or the folded-down rear seats, useful when the rear seats are up, folded down on one side, or folded down completely; removable

Lashing points, four in luggage compartment, to secure loads

Reversible mat, for luggage compartment, velour on one side, rubber on the other, for covering the luggage compartment, including when rear seats are folded down, with fold-out protective sheet for the loading lip and bumper

Equipment

Further interior equipment

Dashboard, padded, with black or beige contrasting cover

Headlining in Alcantara with contrasting seams and attachments in Alcantara, including double sun visors to match the interior colour

Headlining and attachments coordinated with interior colour

Headlining and attachments in black

Audi exclusive headlining in black Alcantara with contrasting seams in light grey. From quattro GmbH

Audi exclusive headlining in black Alcantara, individual choice of colour for contrasting seams. From quattro GmbH

Double sun visors, for driver and front passenger, simultaneous front and side protection possible, gap between visor and door pillar can be closed by means of pull-out extension

Two-tone horn, operating mechanism on inner rim of steering wheel

Electric front and rear windows, with safety system to limit maximum closing force, one-touch opening/closing function; convenience opening/closing via central locking

Floor mats at rear, made from Velour or Fresco (2-tone in multicolour loop design), coordinated with the corresponding footwell trim

Floor mats at front, made from Velour or Fresco (2-tone in multicolour loop design), coordinated with the corresponding footwell trim

Footwell trim, in Velour carpet, alternatively in Fresco carpet, coordinated with the interior colour (Can be ordered via design packages)

Grab handles, four, folding, each recessed into roof

Centre console with air conditioning control panel, ashtray, selector lever, MMI terminal, cigarette lighter, 12 V socket

Sun visors, can be folded and swivelled; on the driver and front-passenger sides, with covered illuminated make-up mirror

Sunblind, manual for the rear window

Sunblind, manual for the rear window and for the rear door windows protects the rear passengers from the effects of direct sunlight

Socket, 12 V, in the front centre console, on the rear right-hand side in the luggage compartment and two in the rear centre console

Audi exclusive carpet/floor mats with leather piping, front and rear, individual choice of colour for mat and piping from a range of Audi exclusive colours. From quattro GmbH

Door trims, in inner panel with Alcantara, integral armrests, colour coordinated with the interior colour

Cigarette lighter and ashtray in the front centre console

Steering wheels/gear levers/controls

Audi exclusive controls in leather, the following items covered in leather: steering wheel rim, selector lever knob and selector lever gaiter. From quattro GmbH

Audi exclusive steering wheel rim, customised with Audi exclusive wood and leather, available as 3 or 4-spoke design and in six different finishes. From quattro GmbH

Electric steering wheel adjustment, adjustable for height and reach, with automatic entry and exit function – so that you can comfortably set your ideal driving position

Steering wheel rim with wooden segments, available as multifunction leather steering wheel with/without gearshift function in 4-spoke design, with wooden segments in Walnut natural and black Leather. From quattro GmbH

Multifunction leather sports steering wheel in 3-spoke design, with full-size airbag and perforated leather, for operating the MMI system, radio, Audio music interface, voice control system and telephone or mobile phone (if additionally fitted); with gearshift paddle switches behind the steering wheel for gear changing; aluminium-look controls

Multifunction leather steering wheel in 4-spoke design, with full-size airbag, for operating the MMI system, radio, Audi music interface, voice control system and telephone or mobile phone (if additionally fitted); optionally heated (can be deactivated). Optionally available in conjunction with Audi lane assist: heated, with gearshift paddle switches behind the steering wheel for gear changing; aluminium-look controls

Selector lever knob in aluminium look

Infotainment

MMI and navigation systems, radio and TV systems, telephone and communications

MMI and navigation systems

Driver information system with colour display, a display provides you with information from the trip computer, Auto Check Control, radio clock and MMI system display functions, high resolution, colour representation provides even greater clarity, 3D representation possible for navigation system

MMI navigation plus with navigation data (hard drive), high-resolution 7-inch colour display with high-quality map display, voice control system (destination entry by means of whole-word voice commands), choice of 3 alternative routes provided, map displays have topographical map colouring and show sightseeing information and 3D city models, route scrolling function, manoeuvring within the map by means of the joystick in the control button, split-screen route information (manoeuvring points, points of interest on motorways, TMC on route), detailed junction map and lane recommendations, dynamic route guidance (where available), additional arrow display in the driver information system with colour display, radio with twin tuner, phase diversity, hard drive can also be used to store music (10 GB), MP3, WMA and AAC-compatible DVD player can also be used for music and video DVDs, two SDHC card readers (for up to 32 GB), includes BOSE Surround Sound

Navigation data (hard drive), contains navigation data for the following countries (where digitised): Andorra, Austria, Belgium, Croatia, Czech Republic, Denmark, Estonia, Finland, France, Germany, Gibraltar, Greece, Hungary, Ireland, Italy, Latvia, Liechtenstein, Lithuania, Luxembourg, Monaco, the Netherlands, Norway, Poland, Portugal, Russia, San Marino, Slovakia, Slovenia, Spain, Sweden, Switzerland, UK, the Vatican City

Please find out from your local Audi partner which equipment is standard and what optional equipment is available in your country.

Rear Seat Entertainment (RSE), with two monitors incorporated into the head restraints with 6.5 inch LCD screens; DVD player with 6-disc changer, two headphones and connections for external sources. From quattro GmbH

Rear Seat Entertainment (RSE) plus, features same as RSE, with additional connection to on-board sound system and TV connection. From quattro GmbH

Rear Seat Entertainment fitting for Audi Genuine Accessories, includes pre-installation wiring and mount for the holders in the driver and front-passenger seat backrests. The appropriate Rear Seat Entertainment package (tablet player with holder) is available as a Plug-and-Play unit from Audi Genuine Accessories

Radio and TV systems

Audi music interface, for connecting Generation 4 and higher Apple iPods, an Apple iPhone (music functionality), USB storage media and MP3 players. The Audi music interface is housed in the glove compartment; it is operated via the MMI navigation plus or a multifunction leather steering wheel. Note: can only be used in conjunction with a special adapter cable (Audi Genuine Accessories). Please contact your Audi partner for information on other compatible MP3 players

Bang & Olufsen Advanced Sound System, surround sound reproduction via 14 loudspeakers each with its own amplifier and exclusive aluminium loudspeaker covers; centre speaker and two automatically extending acoustic lenses on the instrument panel for superb true-to-detail sound performance at every seat; one midrange speaker and woofer in each front door; one tweeter and woofer in each rear door; one subwoofer in the spare wheel well and two surround sound speakers in the D-pillar; dynamic driving noise compensation; 14-channel amplifier; highly efficient ICEpower amplifiers with a total output of more than 1,000 watts, 5.1 surround sound reproduction is possible

BOSE Surround Sound, surround sound reproduction, dynamic driving noise compensation; 10-channel amplifier, 14 loudspeakers, including one centre speaker in the dashboard and two surround sound speakers in the headlining at the rear, subwoofer in the spare wheel well - for an outstanding sound experience; 270 watts total output, 5.1 surround sound reproduction is possible

CD changer, 6-disc CD changer (MP3 and WMA compatible) under the centre armrest, can be controlled via the MMI system; playback of copy-protected music files (DRM) is not possible

CD softbag, for individual storage of up to 24 CDs

Digital radio reception (DAB), digital stations can be received as well as analogue stations. The DAB twin tuner features a second DAB tuner that continually searches for alternative reception frequencies for the selected station; at the same time, the station list is updated. Please note: reception depends on local digital network availability

TV reception, reception of analogue and digital (DVB-T) uncoded television stations (MPEG-2 standard), TV picture, teletext and Electronic Programme Guide (EPG). Facility to connect two external AV sources via the optional adapter cable. Please note: TV reception depends on local analogue and digital network availability. No AV or TV video output whilst the car is being driven. (Audio output is also available whilst the car is being driven)

TV reception and digital radio reception, reception of analogue and digital (DVB-T) uncoded television stations (MPEG-2 standard), TV picture, teletext and Electronic Programme Guide (EPG). Facility to connect two external AV sources via the optional adapter cable. Please note: TV reception depends on local analogue and digital network availability. No AV or TV video output whilst the car is being driven (audio output also available while the car is being driven). Digital radio reception (DAB) also enables reception of DAB-standard digitally-broadcast radio stations in addition to the analogue stations. The DAB twin tuner features a second DAB tuner that continually searches for alternative reception frequencies for the selected station; at the same time, the station list is updated. Please note: reception depends on the availability of local digital networks

Telephones and communications

Audi Bluetooth car phone, your Bluetooth-capable mobile phone can be conveniently connected to the GSM module inside the vehicle (requirement: your mobile needs to have SIM Access Profile), additional SIM card reader located in the surround of the MMI navigation plus. Transfer of phone book entries to the vehicle and management of call lists; easy operation via MMI navigation plus, multifunction leather steering wheel or the voice control system

Wireless handset for the Audi Bluetooth car phone, handset with colour display and integral SIM card reader, for making private phone calls; easy writing of text messages thanks to automatic word recognition. (Can only be ordered in conjunction with the Audi Bluetooth car phone)

Bluetooth interface, Bluetooth-capable mobile phones can be connected with the vehicle via the interface. Hands-free calls are possible in the vehicle via the microphone

Mobile phone fittings (Bluetooth), includes a hands-free facility and voice control for the telephone functions and a fitting for an optional mobile-specific charger; operation via MMI navigation plus, a multifunction leather steering wheel or the voice control system; please contact your Audi partner for adapters and information on compatible mobile phones

Voice control system (included with MMI navigation plus), voice-controlled operation of basic functions for navigation, address book and, if fitted, telephone. Whole-word entry of destination (no spelling out required) and, in conjunction with Audi Bluetooth car phone or mobile phone fitting (Bluetooth), retrieval of up to 2,000 names from the phone book (no programming required)

Safety/technology

Suspension/brakes, assistance systems/safety, technology

Suspension/brakes

adaptive air suspension, electronically controlled air suspension with infinitely variable adaptive damping system on all four wheels, automatically regulates vehicle ride height and damping; five modes (automatic, comfort, dynamic, offroad, lift), can be selected via the MMI system; including ride height control and loading level

Ceramic brake: 20-inch high-performance braking system with carbon-fibre reinforced ceramic brake discs, specially developed cooling ducts in the ventilated and perforated brake discs, brake callipers painted in anthracite with "Audi ceramic" logo

Parking brake, foot-operated

Assistance systems/safety

adaptive cruise control, distance control (control range 0–200 km/h); working within the system's limits, it uses a radar sensor to detect vehicles ahead and maintains the distance by braking and accelerating, four programs can be selected individually via the steering column stalk of the cruise control system; includes braking guard which observes the surroundings and then warns the driver of any imminent collision with a vehicle travelling in front

Airbags: full-size airbags for driver and front passenger, two-stage deployment; front side airbags integrated into the seat backrests

Traction control (ASR), for excellent traction, prevents the drive wheels from spinning

Equipment

Audi lane assist, lane compliance assistant; the system creates a virtual driving lane using a front camera and steering angle sensor; if there is a danger of the vehicle leaving this lane and the indicator has not been actuated, the driver is warned in the form of steering wheel vibrations. (The grey-tinted strip along the windscreen is omitted; can only be ordered with 4-spoke multifunction leather steering wheel)

Audi side assist, lane change assistance, assists the driver when changing lanes (works at vehicle speeds of 30 km/h and above). Working within the system's limits, Audi side assist monitors the area at the side behind the vehicle as it is driving along and informs the driver via a signal in the exterior mirror if the system has detected another vehicle in the adjacent lane; can be activated via the button in the driver's door

Battery energy management, consisting of battery diagnosis, quiescent current management and dynamic energy management; ensures the vehicle is well supplied with electrical power both during a journey and when stationary

Parking system plus, this extended parking aid provides an acoustic and visual indication in the MMI display of the vehicle's distance from an obstacle at the front and rear; measurement is done by ultrasonic sensors concealed in the bumpers

Parking system advanced, acoustic and visual parking aid for the front and rear, image of area behind the vehicle shown on the MMI display, reversing camera concealed in the tailgate handle

Electronic Differential Lock (EDL) on surfaces with varying levels of grip, this start-off assistant automatically brakes the drive wheels on the surface that is too slippery, thereby ensuring smooth, powerful progress; operates at speeds up to approx. 100 km/h

Electronic Stabilization Programme (ESP), with hydraulic Brake Assist; ESP improves stability by targeted braking of each individual wheel and intervention in the engine management system; with extended on and off-road functions, including off-road mode for good traction even when travelling off paved roads; includes hill start and hill descent assist and rollover stabilisation

Cruise control system, maintains any desired speed above around 30 km/h, provided engine power output and engine braking effect permit; operated via separate steering column stalk, at the same time the set speed is also displayed temporarily in the instrument cluster display. (Depiction in the driver information system)

Belt height adjustment for the front seats and outer seats of the 2nd row of seats, manually adjustable

Instrument cluster, with adjustable lighting, round dials for rev counter, electronic speedometer up to 310 km/h, coolant temperature display and fuel gauge; time and date display, odometer and trip odometer, warning and indicator lamps, maintenance interval display. (When combined with driver information system: display for radio frequency, ambient temperature and fuel tank range)

Integral head restraint system, in the event of a rear-end collision the shape of the seat restrains the upper body and supports the head at an early stage. This increases safety and reduces the danger of whiplash

Body, galvanised (fully-galvanised in areas at risk from corrosion), unitary construction, welded to the floor pan, front and rear areas feature defined crumple zones

Childproof safety locks, mechanical for the rear doors and electrical for the rear windows

ISOFIX child seat mounting for the outer seats of the 2nd row of seats, standard bracket for the practical fastening of ISO standard child seats

ISOFIX child seat mounting at front, with deactivation switch for front-passenger airbag bracket for fastening an ISOFIX child seat to the front-passenger seat; includes separate electric childproof safety locks for the rear doors; suitable child seats are available from your Audi partner

Head airbag system, large-area head airbag system, unfolds over the entire length of the side windows in the area extending from the 1st to the optional 3rd row of seats and protects the passengers in the front and outer rear seats in the event of a side impact

Light/rain sensor, to control the automatic headlights and the windscreen wipers; includes coming home/leaving home function: automatic switching on/delayed switching off of fog lights, tail lights and number plate lighting when parking/opening the vehicle

Side airbags at rear, for the outer seats in the second row; supplement the side impact protection in the doors and the head airbag system

Side impact protection in the doors, consisting of high-strength aluminium impact beams

servotronic, hydraulic rack-and-pinion power steering with variable steering ratio; speed-sensitive regulation provides precise steering feel at high speeds and outstanding assistance when parking

Seat belts, three-point inertia reel seat belts for all seats (including for optional 3rd row), with belt height adjustment and belt force limiters for the 1st row of seats and the outer seats in the 2nd row, front seats also have pyrotechnic belt tensioners and seat belt reminder

Safety steering column, supplements the safety potential of the seat belts and airbags

First-aid kit in the storage compartment under the front passenger seat

Warning triangle with bracket on the inside of the tailgate

Warning buzzer, for lights not switched off or activated parking light

Warning and indicator lamps including for: airbag, ABS, ESP/ASR, parking brake on, alternator, lights, main beam, belt warning, indicator lights, brakes, engine oil pressure, engine electronics, immobiliser

Immobiliser, electronic, incorporated in engine control unit, automatically activated by the vehicle key

Technology

quattro® permanent all-wheel drive, with asymmetric/dynamic torque distribution and self-locking centre differential

tiptronic, 6-speed tiptronic with dynamic shift program (DSP) and sports program; power is transferred by a hydraulic torque converter with lock-up clutch

Please find out from your local Audi partner which equipment is standard and what optional equipment is available in your country.

Technical data

Model Audi Q7 V12 TDI quattro

Engine type	V12 diesel engine with common rail injection system and exhaust gas turbocharging
Displacement in cc (valves per cylinder)	5934 (4)
Max. output ¹ in kW at rpm	368/3750
Max. torque in Nm at rpm	1000/1750–3250

Power transmission/wheels

Type of drive	quattro® permanent all-wheel drive
Transmission	6-speed tiptronic
Wheels	Cast aluminium wheels 10 J x 20
Tyres	295/40 R 20

Weights/capacities

Unladen weight ² in kg	2605	[2635]
Gross vehicle weight in kg	3275	[3405]
Roof load/trailer nose weight in kg	100/140	[100/120]
Trailer load limit ³ in kg	unbraked	750 [750]
	12% gradient	3300 [3000]
	8% gradient	3300 [3000]
Fuel tank capacity, approx. in l	100	[100]

Performance/consumption⁴

Top speed in km/h	250 ⁶	[250] ⁶
Acceleration 0–100 km/h in s	5.5	[5.5]
Fuel grade	Diesel in accordance with EN 590	
Fuel consumption ⁵ in l/100 km	urban	14.8 [14.8]
	extra-urban	9.3 [9.3]
	combined	11.3 [11.3]
CO ₂ emissions ⁵ in g/km	urban	390 [390]
	extra-urban	245 [245]
	combined	298 [298]
Emissions standard	EU 4	

[] Data for 6 and 7-seater.

Notes

- ¹ The figure stated was calculated using the specified measuring procedure (current version of Directive 80/1269/EEC).
- ² Weight of car, unladen, with fuel tank 90% full, without driver (75kg), calculated in accordance with EC direction 92/21/EEC. Optional equipment may increase the car's unladen weight and drag coefficient, whereupon the possible payload limit and the top speed will be reduced accordingly.
- ³ The engine's power output always goes down with increasing altitude. At 1,000 m above sea level, and for every additional 1,000 m, deduct 10% from the weight of the outfit (trailer load limit + gross weight of the towing vehicle). Figure for trailer load limit applies to factory-fitted trailer towing hitch. If using the vehicle with a trailer towing hitch for commercial purposes, a digital tachograph may be required under certain conditions.
- ⁴ A vehicle's fuel consumption and CO₂ emissions do not just depend on how efficiently the vehicle uses the fuel, but are also influenced by driving behaviour and other non-technical factors. CO₂ is the greenhouse gas primarily responsible for global warming.
- ⁵ The figures stated were calculated using the specified measuring procedures. The figures do not refer to one individual vehicle and do not form part of any offer, but rather should be used purely for purposes of comparison between the different vehicle models.
- ⁶ Regulated.

Important note

Inspections are due as shown by the service display.

Dimensions

Audi Q7 V12 TDI quattro 5-seater

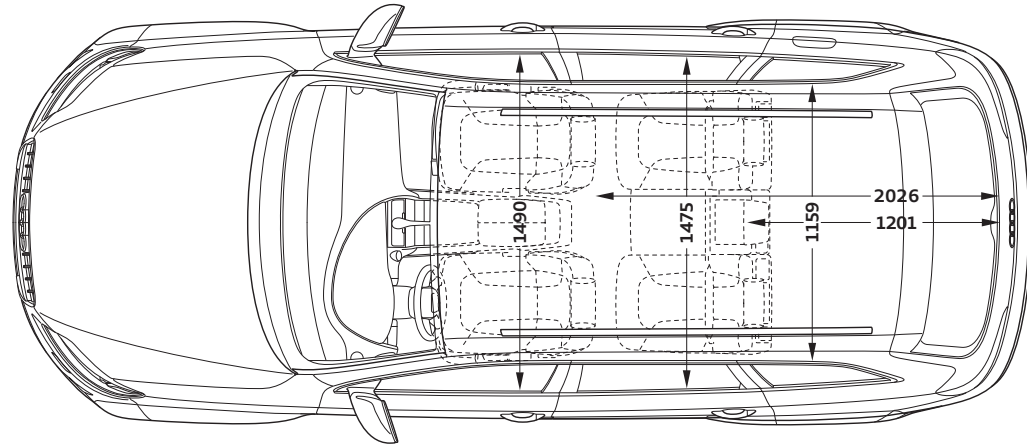
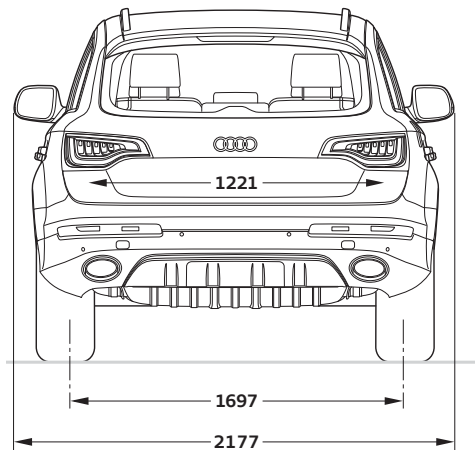
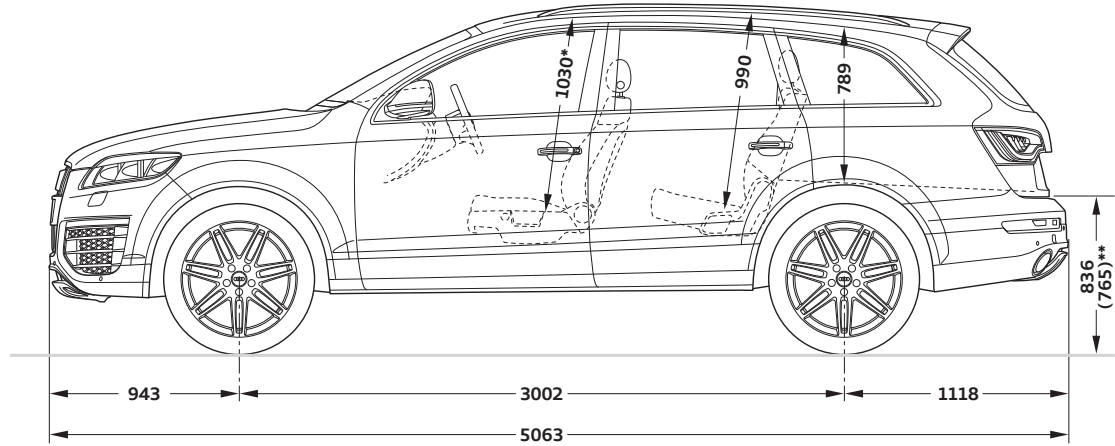
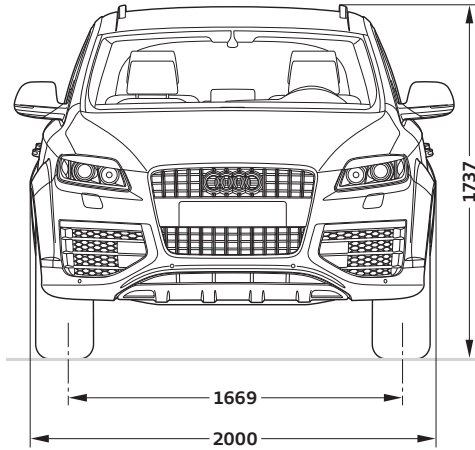

Dimensions in millimetres.

Dimensions were measured with vehicle at unladen weight, ground clearance measured with vehicle carrying its maximum load.

Luggage compartment volume in l: 775/2035 (measured by the VDA test method using 200 x 100 x 50 mm blocks. Second value is with the rear seat folded down and the vehicle loaded up to roof height). Turning circle approx. 12 m

* Maximum headroom.

** With optional air suspension, in loading level.

Audi Q7 V12 TDI quattro 7-seater

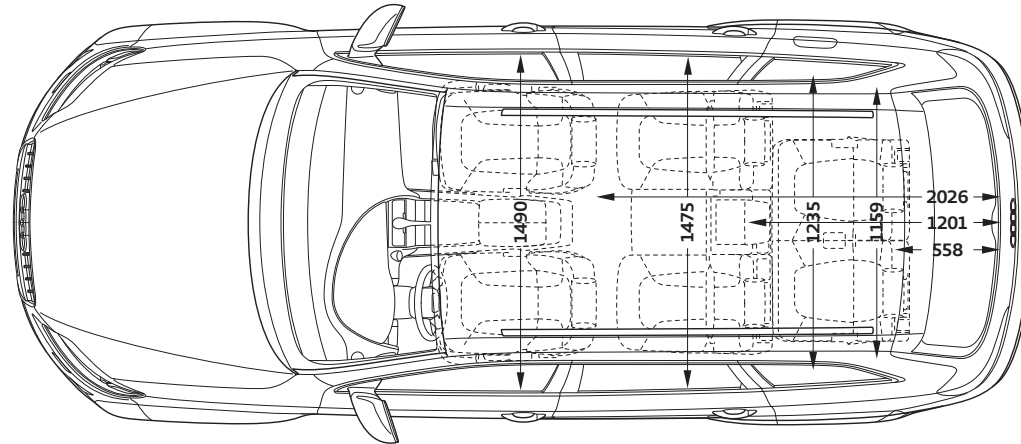
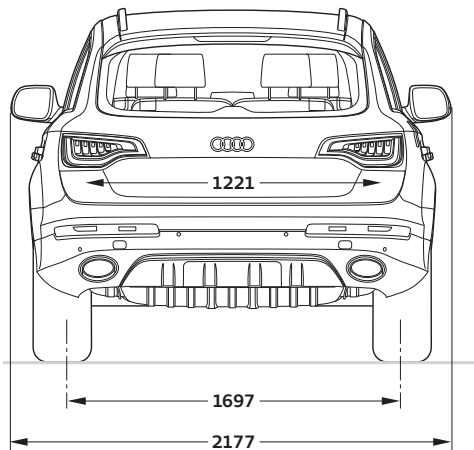
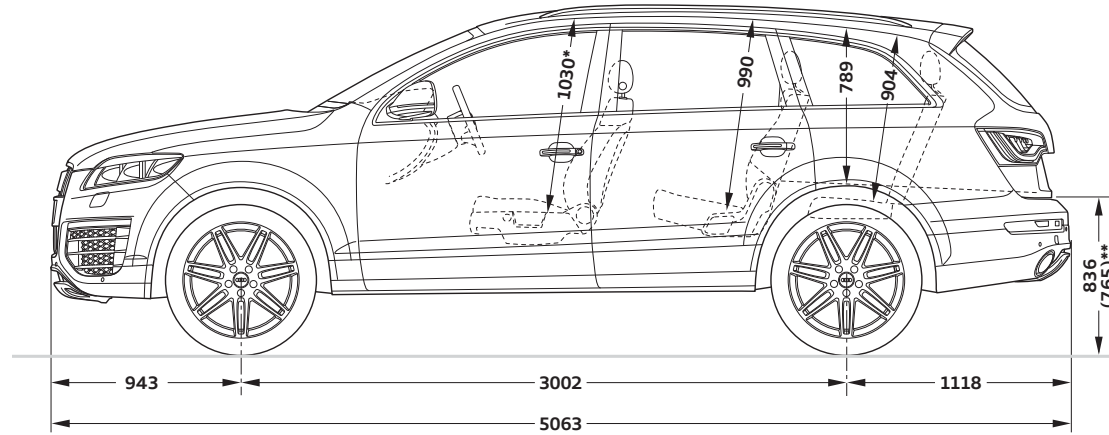
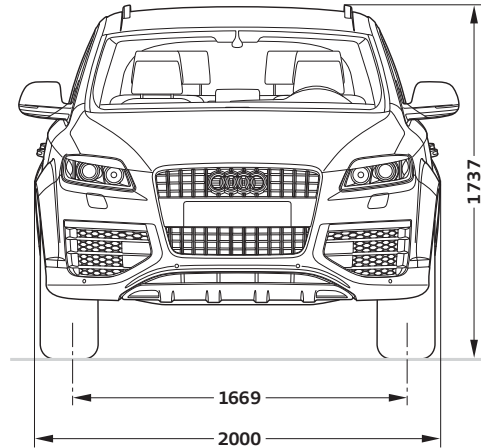

Dimensions in millimetres.

Dimensions were measured with vehicle at unladen weight, ground clearance measured with vehicle carrying its maximum load.

Luggage compartment volume in l: 775/2035 (measured by the VDA test method using 200 x 100 x 50 mm blocks. Second value is with the rear seat folded down and the vehicle loaded up to roof height). Turning circle approx. 12 m

* Maximum headroom.

** With optional air suspension, in loading level.



The path to success leads from the racetrack to the road.

There is a long tradition of motorsport at Audi. And for good reason: Vorsprung durch Technik cannot be better proven anywhere else. With courage, an unconditional drive for perfection and maximum performances at the limit, we were able to celebrate victories from the start. Whether, for example, in rally sport, in the DTM or, as most recently, in 2008, with the diesel-powered Audi R10 TDI at the famous Le Mans 24 hour race. Successes, which you can see reflected in every standard Audi. After all, technical developments should benefit all Audi drivers. On the racetrack. And more than ever on the road.

With Audi, you get much more than an Audi.

Someone who chooses an Audi chooses a brand that offers its customers more.
More individuality. More exclusivity. And more fascination.

Audi configurator

Create your own personal Audi using the Audi configurator.
All current models, engines, colours and equipment are available for you to choose from.

> www.audi.com

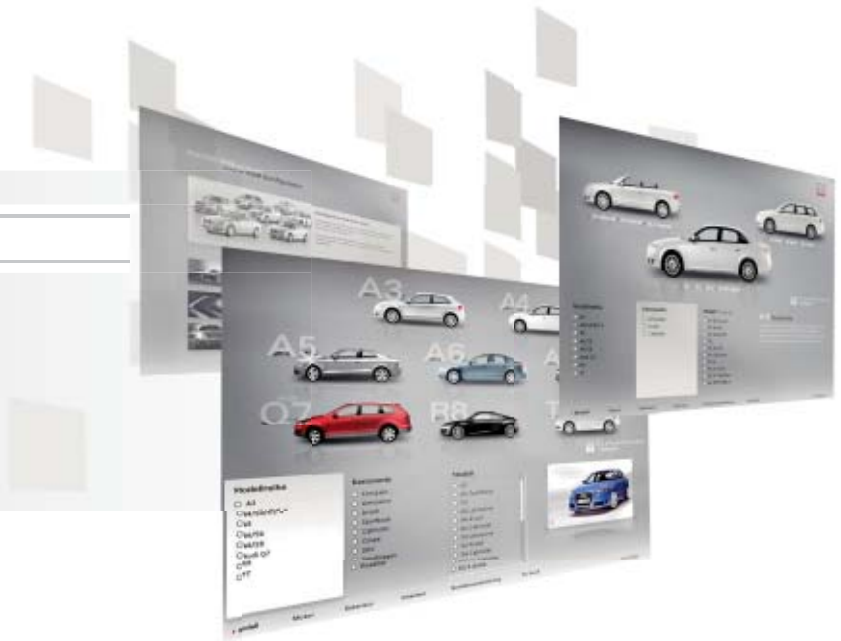

Audi tv

Discover whole new sides to our brand with the four rings on Audi tv: exciting reports on our models, technical innovations, fascinating events from the fields of motorsports, tradition, culture and lifestyle.
Take a look behind the scenes. Every day. Round the clock.

> www.audi.tv



AUDI AG
85045 Ingolstadt
www.audi.com
Valid from July 2009

Printed in Germany
933/1230.71.18

The models and equipment versions illustrated and described in this brochure and some of the services listed are not available in all countries. Some of the cars illustrated are equipped with optional equipment for which an extra charge is made. Details concerning the delivery specifications, appearance, performance, dimensions and weights, fuel consumption and running costs of the vehicle were correct to the best of our knowledge at the time of going to press. Deviations from the colours and shapes shown in the illustrations may occur. No liability is accepted for errors and printing errors. The right to introduce modifications is reserved. Not to be reproduced, including in part, without the written approval of AUDI AG.

This brochure is printed on paper made from pulp bleached without the use of chlorine.