

# Dimensions

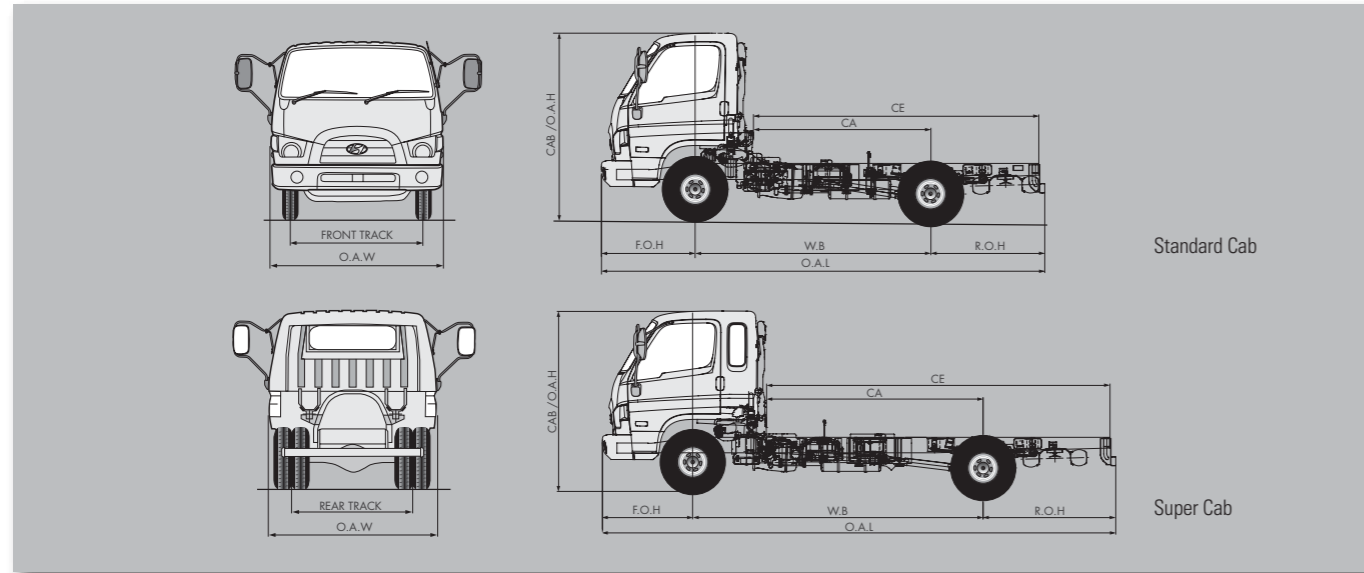

	Standard Cab-Short	Standard Cab-Medium	Super Cab-Medium
<b>DIMENSIONS (mm)</b>			
Wheel Base	2,820	3,415	3,610
Overall length	5,300	6,170	6,380
Overall width	2,010	2,010	2,010
Overall height	2,250	2,250	2,250
Front overhang	1,120	1,120	1,120
Rear overhang	1,360	1,635	1,650
Front track	1,680	1,680	1,680
Rear track	1,495	1,495	1,495
Rear frame width	753	753	753
Chassis height at rear axle	750	750	750
CA	2,125	2,720	2,690
CE	3,415	4,295	4,265
<b>WEIGHTS (kg)</b>			
GVM	4,500	4,500	4,500
GCM	8,000	8,000	8,000
Front loading limit	2,600	2,600	2,600
Rear loading limit	4,400	4,400	4,400
Total cab chassis mass	2,305	2,430	2,475
Front cab chassis mass	1,585	1,640	1,665
Rear cab chassis mass	720	790	810
<b>PERFORMANCE (CALCULATED)</b>			
Speed at max. engine speed	121KPH	121KPH	121KPH
Gradeability at rated GVM	50.7%	50.7%	50.7%
Gradeability at rated GCM	28.1%	28.1%	28.1%
Turning circle (Kerb to Kerb, m)	10.2	12.4	13.0

**WARRANTY**  
**3 YEARS / 200,000 KM** : Standard Vehicle Warranty\*  
 \* For exceptions & exclusions, refer to the Hyundai service passport.

**Truck Assist**  
 National Truck Roadside Assistance  
 for 3 years / 200,000 km

**Hyundai Motor Company Australia Pty Ltd** Corner of 394 Lane Cove Road & Hyundai Drive, Macquarie Park NSW 2113 T. 02 8873 6005  
 Hyundai Motor Company (HMC) and the Hyundai Motor Company Australia (HMCA) each reserve the right to alter vehicle specifications and equipment levels without notice. Some equipment featured on the vehicles in this spec sheet may not be available in Australia or may be optional. To the extent permitted by the law, neither HMC nor HMCA shall be liable to any person as result of reliance on the content of this spec sheet. Please consult your Hyundai dealer for the latest specifications, equipment levels, options, prices and vehicle availability.  
**Note** : Information in this spec sheet is current as at 16/6/2010. **Part No. HCV0901HD45**



# A New Direction HD45



Photo of HD45 Super Cab

## KEY FEATURES

- > Driver's suspension seat with lumbar support
- > Remote keyless entry
- > Computerised battery saver
- > ABS brake with EBD (Electronic Brakeforce Distribution)
- > Fog Lamps
- > Optional super cab

## AT A GLANCE

<b>GVM</b>	4,500kg
<b>GCM</b>	8,000kg
<b>Wheelbase</b>	2,820mm / 3,415mm / 3,610mm
<b>Engine</b>	3.9L, Electronic common rail, 16 Valve SOHC ADR 80/02 (Euro 4) Compliant
<b>Max. power</b>	103kw / 2,700rpm
<b>Max. torque</b>	372Nm / 1,400rpm



## Driveline & Chassis Specifications

### ENGINE (HYUNDAI F140)

Engine	3.9L, Electronic common rail, 16 Valve SOHC ADR 80/02 (Euro 4) Compliant
Displacement	3,933cc
Compression ratio	17.0
Bore x Stroke	103 x 118
Max. power	103kw / 2,700rpm
Max. torque	372Nm / 1,400rpm
Turbocharger	WGT, air-to-air intercooler
Injection system	Common rail system
Emission Control System	Cooled EGR, PMC

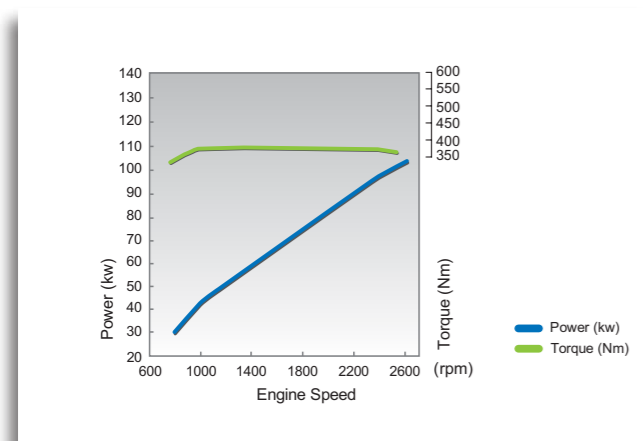

### CLUTCH

Type	Auto adjusting hydraulic control with vacuum assistance
Disc diameter	300mm
Facing lining area	847cm <sup>2</sup>

### TRANSMISSION (M035S5)

Type	5 Speed Manual, Synchronesh on gear 1 ~ 5
Gear ratio	1st 5.380 2nd 3.028 3rd 1.70 4th 1.00 5th 0.722 Reverse 5.380
PTO Opening	PTO provision on LHS of transmission case

### AXLES

Front axle	Reversed Elliot I-beam
Capacity	2,600 kg
Rear axle	Full floating type
Capacity	4,400 kg
Final drive ratio	4.625 : 1

### PROPELLER SHAFT

Type	Tubular, Forged steel ends
------	----------------------------

### BRAKES

Service brake	Auto adjusting front drum and rear drum brakes with dual circuit hydraulic control, vacuum assistance
ABS/ASR	ABS and ASR traction control with electronic brake force distribution(EBD)
Exhaust brake	Vacuum controlled exhaust brake
Parking brake	190mm diameter drum park brake mounted on rear of transmission
Front disc diameter	304mm
Rear drum diameter	320mm

### STEERING

Type	Power assisted ball & nut type gear Tilt & Telescopic Steering Column
Maximum angle:	inside wheel : 44.3°
Maximum angle:	outside wheel : 33.5°

### SUSPENSION

Front Suspension	
Type	Multi-leaf spring
Size x leaves	1,200 x 70 x 11t-1,10t-4
Shock absorber	Double acting hydraulic shock absorber
Stabiliser bar	Equipped (diameter : 30mm)
Rear Suspension	
Type	Multi-Leaf main spring, multi-leaf helper spring
Size(main/Auxiliary)	Main : 1,250 x 70 x 10t-6 Helper : 990 x 70 x 13t-3
Shock absorber	Double acting hydraulic shock absorber
Stabiliser bar	Equipped (diameter : 25mm)

### WHEELS AND TYRES

Wheel type	5.25 x 17.5, five stud
Rim size	
Tyre size	205/75R17.5-10PR, Tubeless
Tyre rating	Steer 1450kg X 2 Drive 1400kg X 4

### FUEL TANK

Type	Frame mounted steel fuel tank lockable fuel cap
Fuel capacity	100 L

### CHASSIS FRAME

Type	Cold riveted ladder type high-tensile frame
Side rail (mm)	193 x 60 x 6.0

### ELECTRICAL

Type	24V electrical system
Batteries	Maintenance-free Batteries 2 x CMF90H(720CCA) batteries connected in series
Battery saver	Battery Auto/Off Device - turns off activated power sources when the vehicle is not in use.
Alternator	55 ampere
Starter capacity	5.5kW starter motor

## Cab Equipment



\*Optional Super Cab

### CAB EXTERIOR

Design	Slant windscreen by 32 degree to reduce aerodynamic drag
Cab mounting	Liquid filled rubber type front and rear cab mounts
Windscreen	Tinted & Laminated windshield with upper partial shade band
Side glass	Solar type of side glass to reduce heat and UV rays
Windscreen wipers	Built-in washer nozzle type of dual wipers, intermittent and two speed mode
Rear vision mirror	Electrically heated exterior main mirrors
Head lamps	Multi focus reflector type headlamps with turn signals
Fog lamps	Built-in type fog lamps
Side Reflector and turn signals on doors	
Reverse alarm	Built-in type reverse alarm
12V power outlet	3 A Nominal, 5 A Peak load

### CAB INTERIOR

Steering wheel	Tilt & telescopic adjustable steering wheel column, power assisted steering with urethane steering wheel for soft grip
Driver's Seat	Contoured adjustable driver's bucket seat with coil suspension and lumbar support
Passenger's Seats	2 seats capacity, foldable centre seat with seat back storage & cup holders
Seat covering	High quality fabric cover
Seat headrest	Height adjustable headrest
Seatbelts	3 point type ELR seat belts for driver's and Passenger's seat, 2-point centre seat lap belt
Overhead console	Driver and Passenger overhead storage shelf with safety net
Grips	Door and side pillar entry assist grips
Interior finish	Fully finished interior trim, padded roof lining and PVC floor mat
Sun visors	Driver and Passenger sun visors
Windows	Electric power windows
Keyless entry	Remote keyless entry and central door locking
Interior lamp	Interior lamp with on/door/off switch
Inside rearview mirror	Day and night type rearview mirror
Air Conditioning	Fully integrated air conditioning with heater and defrost
Door map	Door mounted storage pockets
Audio	CD / MP3 / Audio & Radio
Lighter	24V cigarette lighter

