

CHALLENGER



love that car



LOVE THAT CAR

HERE AT MITSUBISHI, WE LOVE OUR VEHICLES. WE LOVE THEIR SUPERIOR QUALITY,

*WHAT THEY STAND FOR,
AND WHAT THEY'RE CAPABLE OF.*

AND WE WANT YOU TO FEEL THE SAME WAY.

IT'S WHY WE STRIVE FOR THE HIGHEST STANDARDS IN EVERYTHING WE DO,

*AND IT'S WHY WE BACK ALL OUR VEHICLES WITH OUR MITSUBISHI DIAMOND ADVANTAGE,
AUSTRALIA'S BEST NEW CAR WARRANTY, CAPPED PRICE SERVICING AND CUSTOMER CARE.*





STREET PRESENCE

We design attention grabbing vehicles with real street presence. We're focussed on delivering vehicle design that not only defines the best in innovation but embodies the essence of genuine performance, handling dynamics and absolute driving pleasure.



ADVANCED TECHNOLOGY

We'll continue to develop ground-breaking technology that focuses on better control, performance and lifestyle. This includes innovations such as our Mitsubishi All Terrain Technology (MATT™), our variable geometry turbo diesel engine and our leading Mitsubishi Multi Communication System (MMCS).



DRIVER CONFIDENCE

We're committed to raising the bar in terms of safety, which gives peace of mind to all occupants. Our Mitsubishi Reinforced Impact Safety Evolution (RISE) body design remains at the heart of our vehicle safety philosophy. Mitsubishi's leading active safety features like Active Stability Control and Traction Control puts Challenger at the forefront of safety technology.



SUPERIOR VALUE

We'll constantly strive to deliver the ultimate customer experience at all times. This is reflected by the Mitsubishi Diamond Advantage, Australia's best new car warranty, capped price servicing and customer care, by our feature-packed vehicles, and our ongoing commitment to making our vehicles more cost effective and fuel efficient.



OUR PROMISE

When you buy a Mitsubishi Challenger, or any vehicle from our range, you're buying a vehicle that's backed by world-class research, technical innovation, and leading performance. In every area of our business, we're continually focussed on four key values. By following these values, we never fail to create superior vehicles that people love.

When you're a busy family your day can be hectic. You're always in and out of the car, running multiple errands and transporting anything from school bags to surf boards. We know that when it comes to doing all this, you want to be comfortable. You want a car you can rely on, feel confident and relaxed in, and be proud of when you sit behind the wheel. It's for these reasons that we designed the new, versatile Mitsubishi Challenger.

Challenger's stylish new design fuses Mitsubishi's proven 4WD credibility with the sleek and refined lines of a sporty SUV. The result is a vehicle that looks comfortable anywhere you are – whether it's an inner-city street, a busy freeway, or a remote rocky coastline.

The well-presented Challenger, LS and premium XLS models have a spacious versatile interior that will make driving a pleasure. Under the bonnet, you'll find a fuel-efficient, 2.5L intercooled turbocharged Diesel Engine with the very latest in Mitsubishi's Common Rail Direct Fuel injection system. And thanks to Mitsubishi's Super Select 4WD system, you can cross from city streets to the great outdoors with the flick of a lever.

MITSUBISHI CHALLENGER
HAS EVERYTHING YOU WOULD EXPECT
FROM A **STYLISH** *FAMILY* SUV
PLUS THE ABILITY TO TRULY ESCAPE
TO THOSE FAVOURITE GETAWAYS
OFF THE BEATEN TRACK.





The Challenger features refined and luxurious styling and incredible seating versatility – so you can fit up to a family of seven with ease. Mitsubishi Challenger's ready for anything your family can throw at it. You can choose between two row (five-passenger) or three row (seven-passenger) seating options. The third row has a 50/50 split fold providing a variety of seating configurations.

Challenger's high driving position provides a confident view of the traffic around you. The stylish interior is durable to withstand all the family activities such as swimming lessons, trips to the beach or even weekend adventures. The interior is distinguished by clean, sleek, unbroken surfaces. The soft-touch upholstery, chrome interior handles and elegant wood-print inlays add an extra element of style. As well as leather seat trim, a leather bound steering wheel, gear shift and transfer lever, power windows, plus driver and front passenger power seats with slide, dual height and reclining functions.

Put control at your fingertips – with the Mitsubishi Multi Communication System (MMCS). Enabled by a single touch screen, the MMCS has advanced satellite navigation functions and reversing camera. Fully iPod compatible you can charge and control your iPod, and it even has Bluetooth® phone connectivity.



*ENJOY A
COMFORTABLE
DRIVE NO MATTER
WHERE YOU'RE HEADING.*



XLS model shown with optional MMCS

WHETHER YOU'RE CRUISING ALONG
CITY STREETS OR EXPLORING
RUGGED TERRAIN, THE MITSUBISHI CHALLENGER IS READY
 FOR ANYTHING YOUR FAMILY CAN THROW AT IT.
 POWERED BY A 131kW, 2.5L INTERCOOLED
TURBOCHARGED
 COMMON RAIL DIRECT INJECTION DIESEL ENGINE,
THE CHALLENGER DELIVERS
 FLAWLESS PERFORMANCE AND OUTSTANDING FUEL ECONOMY



3 TONNE TOWING CAPABILITY

Challenger is equipped with a powerful 3,000kg towing capacity. The turbo diesel engine and full-time 4WD capability will make towing the boat, caravan or trailer on your next family adventure a breeze.

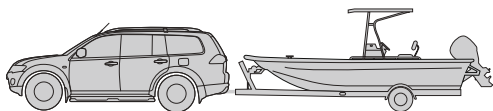

2.5L COMMON RAIL HI POWER TURBO DIESEL WITH VGT

Challenger offers the latest in Common Rail turbo diesel technology. An enhanced variable geometry turbocharger (VGT) works to optimize the turbine flow rate in order to achieve high torque at low speeds and maximised power at high speeds. The result is excellent emission control, fuel efficiency and high engine power for superior performance. The 2.5 litre turbocharged diesel engine yields next generation quietness, smoothness and fuel efficiency, taking you further for less without compromise, with an impressive 131kW of power and 400Nm of torque for the manual and 350Nm for the automatic.



5 SPEED SPORTS MODE AUTOMATIC

Sports Mode allows you to enjoy the ease and comfort of an automatic, with the option of then switching to the versatility and control of a 5 speed manual without the use of a clutch pedal.

The clutch free operation reduces the rev and torque loss usually associated with engaging gears, meaning you can maintain momentum in off-road situations.

PADDLE SHIFTS

When the gear shift is in Sports Mode position, paddles on the Challenger steering wheel allow you to make lightning quick gear changes without your hands leaving the wheel.

COMPARISON OF SHIFT RESPONSE

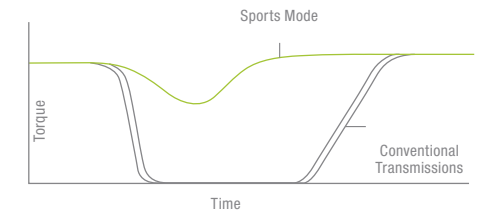

INVECS II SMART LOGIC

The Smart Logic transmission system learns and adapts to each driver's preferences by monitoring acceleration and foot brake data. The control logic then adapts the gearshift timing to suit your driving style.

ADAPTIVE SHIFT CONTROL DURING ACCELERATION



ADAPTIVE SHIFT CONTROL GOING DOWNHILL

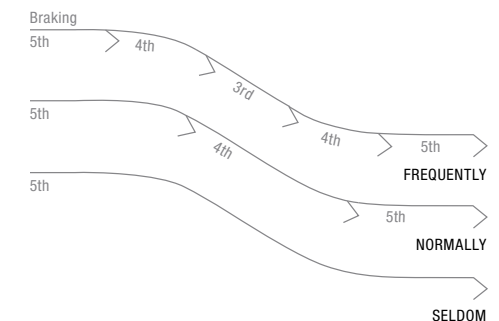

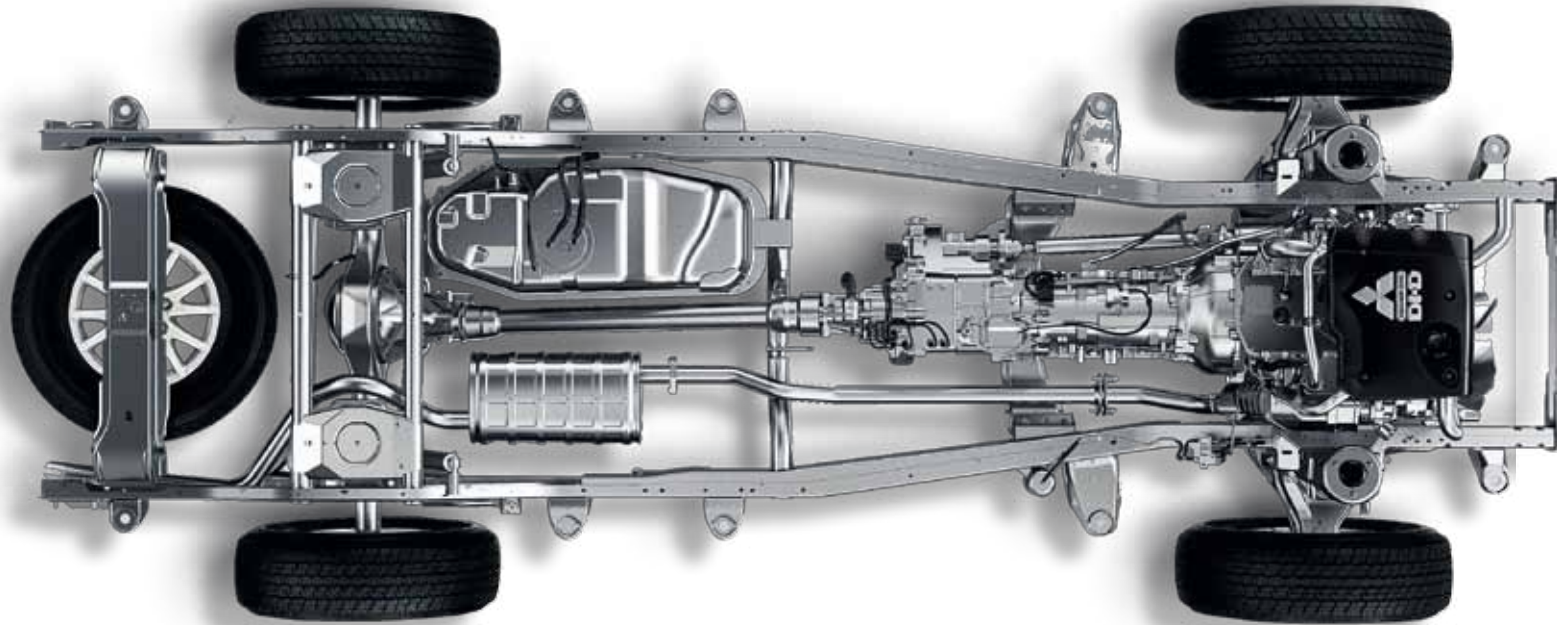

MATT
 MITSUBISHI ALL TERRAIN TECHNOLOGY

Mitsubishi brings you the latest safety systems and superior 4WD technology. Challenger boasts rally proven MATT™ (Mitsubishi All Terrain Technology) for the ultimate in on and off road driver confidence. When it comes to giving you superior control we've left no stone unturned. So Challenger can take you places other conventional SUVs would struggle with.

Challenger is seriously 4WD capable thanks to its advanced 4WD system. Enjoy the confidence of knowing that whatever the destination you want to escape to with your family, Challenger will be up for the challenge.

SUPER SELECT 4WD

The versatile Challenger inherits the 4WD-handling heritage from a long line of Mitsubishi rally champions. Superior to conventional SUVs, Challenger's Super Select 4WD offers full-time 4WD with the option of four driving modes as seen below. The Super Select 4WD system also offers the benefit of on-the-fly shifts from 2WD to 4WD high range at speeds of up to 100km/h.



2H (2WD High Range)

Whether you're cruising down the highway or just going across town, 2H mode shifts you into rear-wheel drive for smooth, quiet, fuel-efficient performance.



4H (Full-Time 4WD)

When the weather turns bad and the road gets rough, get added traction in 4H mode. Challenger's Super Select 4WD system offers the flexibility of a centre-differential with viscous coupling unit, providing excellent traction in unpredictable road conditions or on volatile surfaces.



4HLC (4WD High Range w/ Locked Centre Differential)

Keeping you on track in rugged or slippery conditions, 4HLC distributes power equally to all four wheels to meet off-road challenges with a steady sense of control.



4LLC (4WD Low Range w/ Locked Centre Differential)

Switch to 4LLC when you need all the tractor-like crawling power your Mitsubishi 4WD is capable of. Maximised low-end torque pulls you through even the roughest terrain, sandiest dunes, or deepest snow to get to that isolated spot that only a truly capable 4WD can take you.

THE CHALLENGER

FEATURES SEVERAL IMPORTANT

SAFETY INNOVATIONS

TO PROTECT YOUR FAMILY.

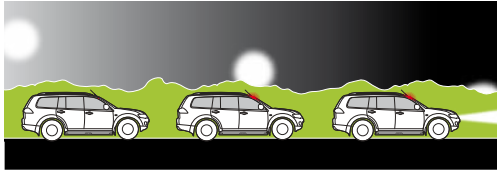

DUSK SENSING HEADLAMPS

Help you stay focused on the road at all times. A sensor on the windscreen automatically sends a signal to your lights and they will turn on when it gets dark or when you're travelling through a tunnel.

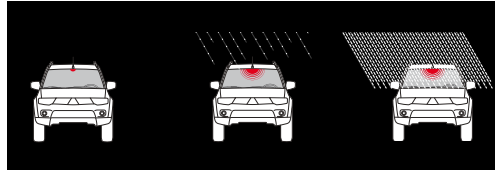

AUTO RAIN SENSING WIPERS

A sensor automatically detects moisture on the windscreen and according to the amount of rain present the system will activate the wipers at the appropriate speed.



SIX SRS AIRBAGS

To provide essential protection for your family in the event of a collision, Challenger is available with up to six airbags. The side airbags inflate from the side of the seat to protect the torso while curtain airbags activate from the roof to protect the head. The front seatbelt systems also include pretensioners and force limiters that combine to minimise the potential for serious injury in the event of a collision.

RISE SAFETY

At the heart of any integrated safety system is outstanding design. The Mitsubishi Reinforced Impact Safety Evolution (RISE) design combines an energy absorbing front section with a strong, rigid occupant cell to provide outstanding family protection in the event of an accident. The RISE body is coupled with a rigid ladder frame, side impact bars, and collision absorbing joints.

VISIBILITY

Challenger gives you the confidence of a high driving position that provides you a commanding view of the traffic conditions ahead. Large electric rear view mirrors and a reversing camera provide excellent visibility behind. In addition, rear parking sensors provide complete confidence and reassurance when reversing.

REVERSING CAMERA & REVERSING SENSORS

The MMCS reversing camera supports the driver's rear field of view, automatically appearing on screen when the reverse gear is engaged. In conjunction with the reversing sensors, which alert you when you are getting close to objects, it makes parking in tight spots a breeze. It also offers safety and peace of mind when you are backing in and out of driveways.



HIGH INTENSITY DISCHARGE HEADLAMPS (HID)

Clever self levelling HID headlamps offer brighter illumination for night time driving and automatically adjust the beam level when towing. The washer system ensures HID performance is always optimal.



MULTI-MODE ABS



Multi-mode Anti-Lock Braking System

This allows you to manoeuvre around objects under heavy braking conditions. Challenger's intelligent 4-channel, 4-sensor braking system works in conjunction with the drive mode to monitor different wheel speeds and activate brakes to individual wheels when required to deliver superior control.

EBD

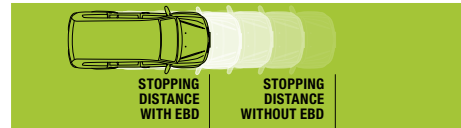

Electronic Brakeforce Distribution

This technology reduces stopping distances by detecting passengers or heavier loads and automatically increases rear-braking force.

ATC

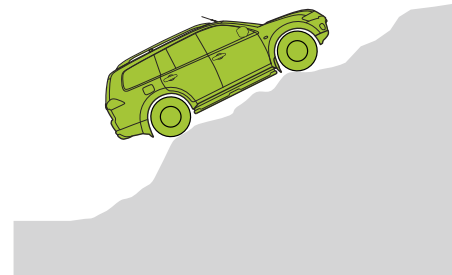

Active Traction Control

Helps you maintain traction on the most slippery or rugged of surfaces. This intelligent system automatically controls the engine output, so driving wheels are prevented from spinning. Sensing loss of traction in an independent wheel, it applies braking force to that wheel and sends extra power and torque to other wheels with traction to keep you moving.

ASC

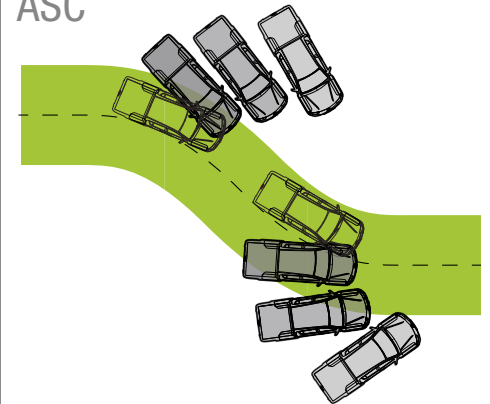

Active Stability Control

Maintains stability and prevents loss of control when cornering, automatically recognising under-steer and over-steer and applying braking force to the diagonal wheel to keep you online through corners.

SETTING THE STANDARDS IN SUSPENSION

Double-wishbone front suspension with coil springs combined with a 3-link coil spring rear suspension, both with stabiliser bars, give unmatched traction and stability with a high ground clearance for your off-road adventures.

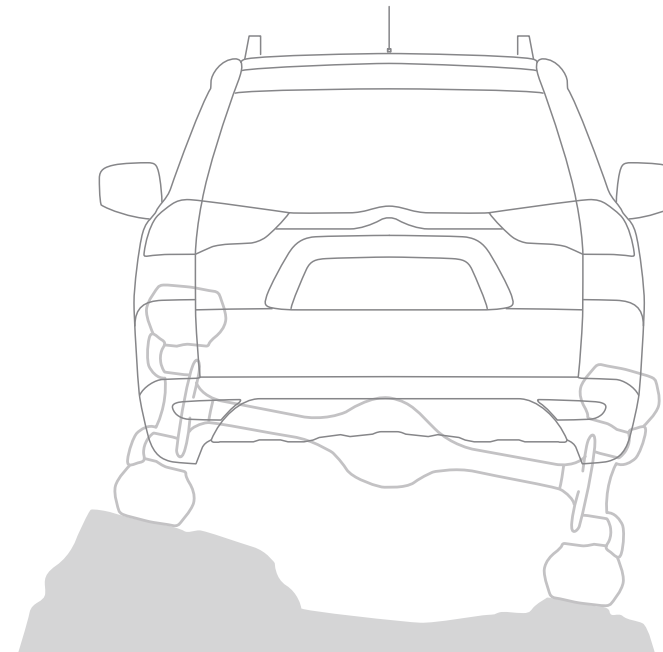

REAR DIFFERENTIAL LOCK

Challenger is available with rear diff lock to provide superior traction for heavy duty four wheel driving. When locked, both wheels receive the same amount of driving force, regardless of surface - meaning maximum possible traction in difficult situations.

WITH **VERSATILITY** THAT HAS BEEN **DESIGNED**
WITH THE **FAMILY** IN MIND, CHALLENGER BOASTS A
RANGE OF CONVENIENCE FEATURES,
CLEVER STORAGE AND SEATING CONFIGURATIONS.



Overseas model shown

SEATING COMFORT

Challenger is available with either tan or black leather facing front and second row seats, whilst both the driver and passenger seats are power adjustable.

CRUISE CONTROL

When it comes to travelling long distances for family getaways it's important to be as comfortable as possible. Thanks to Challenger's easy-to-use cruise control, you can stay relaxed on the open road, reduce fuel consumption and avoid the risk of accidental speeding. Simply set your specific speed, sit back and enjoy the drive.



STORAGE

Clever storage areas throughout the cabin ensure there's plenty of room for everything an active family could need. A handy, underfloor compartment in the seven seat option also provides extra storage when you really need it.



POWER WINDOWS

Challenger makes it easy to enjoy the scenery or to keep the weather outside at bay with the convenience of power windows.

The driver's window also has a convenient auto up and down function.





CARGO AREA

Sometimes, instead of getting away from it all you want to take it with you. Challenger's spacious cargo area can fit those large cargo items, and the folding seats give you that extra room to carry any additional suitcases, golf bags, kids toys or whatever else your family might need. And with the easy-opening tailgate, loading and unloading everything is a breeze.

SEATING CONFIGURATION

Challenger has plenty of room for the whole family with five seats and the option of a third row of two additional – seven comfortable seats.

The front seats fully recline to provide a flat surface together with the rear seats.

The second row seats have slide, recline and tumble-forward flexibility. This means you can easily create extra room when it's needed, whether it's for school bags, camping gear, sporting equipment, or even just everyday shopping.

The third row seats have a recline function and can fold away to allow for extra luggage space.



CHALLENGER BOASTS A RANGE OF
NEXT GENERATION TECHNOLOGY
 THAT AIMS TO MAKE ACTIVE FAMILY LIVING
**SIMPLE, STRESS FREE
 AND FUN.**



MITSUBISHI MULTI COMMUNICATION SYSTEM (MMCS)*

MMCS is an integrated communication and media system that provides satellite navigation, audio control, DVD function and a host of other features, controlled via the 7" full colour in dash touch screen. MMCS also shows audio settings with digital display for equaliser, surround sound and listening positioning.

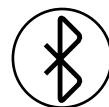

BLUETOOTH® PHONE CONNECTIVITY

Challenger has the latest Bluetooth® phone connectivity that allows you to operate calls using the vehicle's audio system. With MMCS calls can be made and received using the touch screen, allowing you to stay focused on the road ahead.



MITSUBISHI POWER SOUND SYSTEM

Mitsubishi's exclusive sound system delivers high power audio output throughout the interior via a 420W high power amp, and 8 speakers including 4 tweeters. Speakers are placed for optimal sound balance and maximum enjoyment of all occupants from front to rear.



CONNECT YOUR OWN MUSIC

Incorporating the latest technology to make every drive a pleasure, the MMCS is iPod compatible – which means you can connect, charge and play your iPod. Challenger also has an audio input jack allowing you to connect and play MP3s whenever you like.



MULTI FUNCTION DISPLAY*

The Multi Function Display provides handy vehicle information such as fuel consumption, a trip computer and outside temperature functions. You can configure the display to show you exactly the information you want.

*When MMCS option is selected, the Multi Function Display is deleted and the trip computer and environment functions including range to empty, average fuel consumption, altimeter, barometer and outside temperature display are disabled.

MITSUBISHI DIAMOND ADVANTAGE
AUSTRALIA'S

BEST NEW CAR WARRANTY AND CUSTOMER CARE

WHEREVER YOUR ROAD TAKES YOU, WE'LL BE RIGHT THERE WITH YOU.
IT'S PART OF OUR COMMITMENT TO ENSURING YOU ENJOY COMPLETE DRIVING
PLEASURE WHENEVER YOU GET BEHIND THE WHEEL OF YOUR MITSUBISHI.
NOTHING DEMONSTRATES THIS COMMITMENT BETTER THAN OUR

UNIQUE DIAMOND ADVANTAGE CUSTOMER CARE PACKAGE.

10 | **5**
YEAR | YEAR
**MITSUBISHI
DIAMOND
ADVANTAGE**
AUSTRALIA'S BEST
NEW CAR WARRANTY*,
CAPPED PRICE SERVICING*
AND CUSTOMER CARE*

WARRANTY 10/5YR	CUSTOMER ASSIST 24/7	5YR ROADSIDE ASSIST	CAPPED PRICE SERVICING	GENUINE SERVICE	GENUINE PARTS	200+ DEALER NETWORK	FINANCE	INSURANCE
Mitsubishi Motors Australia Limited offers a 10 year/160,000km (whichever comes first) non-transferable Powertrain Warranty, a 5 year/130,000km (whichever comes first) New Vehicle Warranty and a 5 year Perforation Corrosion Warranty on all Mitsubishi cars and light commercial vehicles. Service conditions apply. See your dealer for details.	We're here to help, 24 hours a day, seven days a week. So just call Mitsubishi Motors Australia Customer Assistance Centre on 1300 13 12 11 if you have any questions, or for the location of your nearest Mitsubishi Dealer.	Peace of mind is guaranteed anywhere in Australia with our free 5 year/130,000km (whichever comes first) Roadside Assist, 24 hours a day, 365 days a year. Our fast, comprehensive roadside service offers assistance, repairs, towing and storage. Our Premium Roadside Assist clients also enjoy the added benefits of accommodation, medical and transport facilities. Service conditions apply.	Enjoy 'no surprises' certainty when you book your Mitsubishi in for its regular service requirements. Your servicing costs will be capped for the first 4 years or 60,000km of driving, whichever occurs first up to the first four Regular Services and eight Regular Services for Ralliart and Lancer Evolution vehicles. Conditions apply.	Mitsubishi offers one of Australia's best service intervals of 12 months/15,000 km (whichever comes first). Regular scheduled servicing ensures the long-term reliability and safety of your Mitsubishi and our Scheduled Service Program also helps protect your car's resale value.	Your Mitsubishi will be serviced regularly by skilled Mitsubishi-trained technicians. Only Mitsubishi Genuine Parts are fitted to your car during scheduled servicing – parts that have been fully tested and meet Mitsubishi's stringent quality control. All these parts carry the Mitsubishi Genuine Parts 12 months/20,000 km (whichever comes first) guarantee.	With a network of more than 200 dealers, Mitsubishi is never too far away.	Take the burden out of financing your new Mitsubishi vehicle with our competitive range of finance products, developed by Mitsubishi Motors Australia Limited and St. George Motor Finance Limited.	With the sound backing of Swann Insurance and Mitsubishi Motors Australia Limited, Mitsubishi owners can choose between vehicle and personal protection solutions including motor vehicle, gap cover and loan protection insurance as well as a range of tailored warranty policies.



†10 year or 160,000km Powertrain Warranty (whichever comes first) (non transferable). 5 year or 130,000km New Vehicle Warranty (whichever comes first).
^5 year or 130,000km Roadside Assist (whichever occurs first). Service conditions apply. *4 year or 60,000km Capped Price Servicing (whichever comes first).
Conditions apply. See your Dealer for full details.

11MY – January 2011

mitsubishi-motors.com.au

Specifications and features may vary by model. Please refer to the Specifications Booklet enclosed or mitsubishi-motors.com.au for full information.
As features can change without notice, confirm the equipment level of your vehicle with your Mitsubishi dealer. cha1101. MIT4023.



CHALLENGER

SPECIFICATIONS & FEATURES



love that car



MITSUBISHI CHALLENGER – KEY FEATURES BY MODEL



CHALLENGER

Mechanical

2.5L High Power Common Rail Direct Injection
Turbo Diesel
5 speed manual transmission
5 speed Sports Mode automatic transmission (optional)
with INVECS II Smart Logic
Super Select 4WD
Centre differential with viscous coupling unit
Auto free wheeling hubs
Power steering
Front & rear recovery points

Exterior

16" x 7" Alloy wheels
Steel spare wheel
Body coloured bumper
Body coloured fender flares
Front & rear mudflaps
Front skid plate
Side steps

Interior

Door trim cloth inserts
Carpet floor covering

Comfort

Air Conditioning
Pollen filter
Tilt adjustable steering column
Side and rear window demisters
Driver's foot rest
Passenger assist grips (4)
Rear seat heater ducts

Convenience

Cruise control
Central locking with remote keyless entry
Power windows front and rear (driver auto up & down)
Power door mirrors
Variable intermittent windscreen wipers
Intermittent rear wiper and washer
Accessory power socket (2 – cargo & instrument panel)
Front map lamps
Cargo area lamp
Rear passenger reading lamp
Tailgate inside grip
Interior lamp with time delay
Ignition key cylinder illumination
Digital clock display
Driver sunvisor with ticket holder
Passenger sunvisor with vanity mirror
Tachometer
Headlamps on warning
Cigarette lighter
Instrument lamp with variable dimming control
Low fuel warning lamp
4WD indicator lamp
Remote fuel filler release

Storage

Glovebox – illuminated and lockable
Floor console with upper and lower storage
Door pockets – front and rear
Cup holders (2)
Bottle holders in front & rear doors
Coat hooks (2)
Seat back pocket – passenger
Cargo tie down hooks – 4¹

Seating

Cloth seat trim
Front seats
Bucket seats
Slide and recline adjustment
Driver height adjustment
Height adjustable headrests
Second row seats
60:40 split folding function
Recline and tumble fold up function adjustment
Centre armrest with cupholders
Height adjustable headrests (3)

Audio & Media

Anti Theft AM/FM radio/CD/MP3 player
4 speakers
Multi function display²
colour screen, includes trip computer, outside
temperature, and average fuel consumption
Audio input cable

Safety

Driver & front passenger SRS airbags
Multi-mode Anti-lock Braking System (ABS)
Electronic Brakeforce Distribution (EBD)
Power brake booster
Active Stability Control (ASC)
Active Traction Control (ATC)
Reinforced Impact Safety Evolution (RISE) body
Side door impact beams
3 point Emergency Locking Retractor (ELR) seatbelts
(all seating positions)
Auto Locking Retractor (ALR) seatbelts on outbound
second row seats

Front seatbelt pretensioners & force limiters
Front seatbelt height adjustable shoulder anchorages
Seatbelt warning lamp – driver
Child proof rear door locks
Child restraint anchorage points (3)

Security

Anti-theft encrypted engine immobiliser
Steering lock
Diamond Advantage roadside assistance – 5 years

Options

Rear diff lock + roof rails
Side & curtain airbags + roof rails



LS (Features Additional to Challenger)

Mechanical

- Paddle shifts (automatic only)
- Rear diff lock

Exterior

- 17" alloy wheels
- Alloy spare wheel
- Chrome door mirrors
- Chrome door handles
- Roof rails

Interior

- Leather bound steering wheel
- Leather bound transmission shift
- Leather bound 4WD transfer lever
- Chrome inner door handles

Comfort

- Automatic climate control air conditioning

Convenience

- Power door mirrors with electric folding control
- Steering wheel audio controls

Audio & Media

- Audio input jack
- 6 speakers
- Bluetooth phone connectivity³

Safety

- Side SRS airbags (driver & front passenger) & curtain SRS airbags

Options

- Third row seats – Automatic models only
- Increase seating capacity to 7
- 50:50 fold & tumble function
- Rear manual control air conditioning
- Rear cup holders (2)
- Rear underfloor storage

XLS (Features Additional to LS)

Mechanical

- 5 speed Sports Mode automatic with INVECS II Smart Logic

Exterior

- Privacy glass
- Chrome radiator grille
- Body coloured side protection mouldings
- Body coloured licence plate garnish with chrome highlight
- Fog lamps
- Headlamp washers

Interior

- Woodprint accent panels
- Cargo blind (5 seat model only)
- Cargo room net (5 seat model only)
- Driver sunvisor with vanity mirror

Seating

- Leather seat facings
- Power driver and passenger seat with dual height, recline and slide adjustment

Convenience

- Rain sensing wipers
- Dusk sensing headlamps

Audio & Media

- Mitsubishi Power Sound System premium 420 Watt audio with 8 speakers (includes 4 tweeters)

Safety

- Reverse parking sensors
- High Intensity Discharge (HID) headlamps with auto levelling system

Options

- Third row seats – Automatic only
- Increase seating capacity to 7
- 50:50 fold and tumble function
- Rear manual control air conditioning
- Rear cup holders (2)
- Rear underfloor storage

- Mitsubishi Multi Communication System (MMCS)
- Satellite navigation
- Reverse camera

¹2 cargo tie down hooks available when seven seat option is selected on LS and XLS models.

²When MMCS option is selected, the Multi Function Display is deleted and the trip computer and environment functions including range to empty, average fuel consumption, altimeter, barometer and outside temperature display are disabled.

³Bluetooth® phone connectivity depends on your phone compatibility.

CHALLENGER SPECIFICATIONS

Engine	All models
Type	2.5L Hi-Power 4 cyl, DOHC, 16 valve Common Rail Diesel with Intercooled Turbocharger
Engine code	4D56
Bore x Stroke	91.1mm x 95.0mm
Capacity	2,477cc
Compression Ratio	16.5:1
Maximum Power	131kW @ 4,000rpm
Maximum Torque M/T	400Nm @ 2,000rpm
Maximum Torque A/T	350Nm @ 1,800rpm



2.5L HP Common Rail DI-D Engine

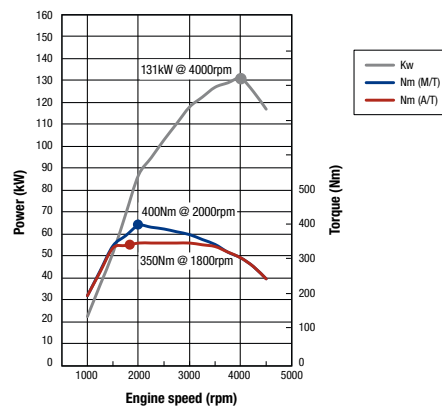

Wheels/Tyres	Challenger	All models
Wheels	16" x 7" Alloy wheels	17" x 7.5" Alloy wheels
Tyres ¹	265/70-16 HT	265/65R-17 112S

Electrical System	
Battery	95D31L
Alternator	12V-90A

Four Wheel Power Assisted Brakes with ABS and EBD	
Front	16" Ventilated discs, single piston calipers
Rear	16" Ventilated discs (in drum)

Suspension	
Front	Independent – Double wishbone coil spring & stabiliser bar
Rear	3-link coil spring & stabiliser bar

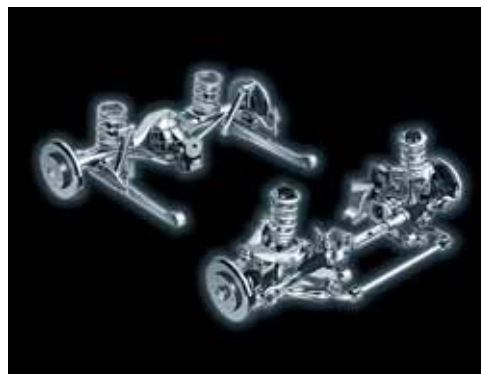

Transmission	Challenger	LS	XLS
5 speed manual transmission	S	S	-
5 speed Sports Mode auto transmission with INVECS II Smart Logic	O	O	S
Super Select 4WD	S	S	S

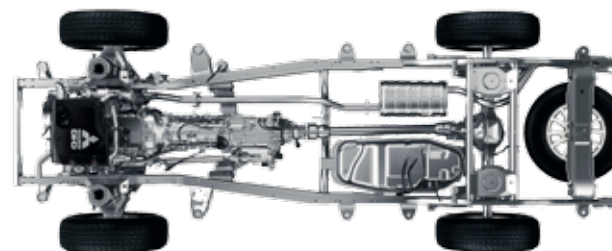

Transmission Ratios	5 speed manual transmission	5 speed Sports Mode auto transmission with INVECS II Smart Logic
first	4.313	3.789
second	2.330	2.057
third	1.436	1.421
fourth	1.000	1.000
fifth	0.788	0.731
reverse	4.220	3.865
Final Gear Ratio	3.917	3.917
Clutch	Dry single disc clutch with diaphragm spring, hydraulic action	3 element torque converter with lock-up and transmission oil cooler

Transfer Ratio	5 speed manual transmission	5 speed Sports Mode auto transmission with INVECS II Smart Logic
High	1.0	1.0
Low	1.9	1.9

Fuel System	5 speed manual transmission	5 speed Sports Mode auto transmission with INVECS II Smart Logic
Fuel consumption [^] (ADR81/02) litres per 100km	8.3	9.8
Fuel Supply Equipment	Electronic Direct Injection – Common Rail	
Fuel Tank Capacity (L)	70L	

[^]These figures are obtained by controlled laboratory tests conducted by Mitsubishi Motors to Australian Design Rule ADR81/02 and are provided to assist you in comparing the fuel consumption of Challenger with other vehicles. The actual fuel consumption you achieve will depend, however, on many factors, including your driving habits, the prevailing conditions and your vehicle's equipment, condition and use.

¹The tyres fitted to Challenger as standard equipment are designed primarily for use on sealed roads. If your Challenger is to be driven on unsealed roads, please consult your Mitsubishi dealer for advice on suitable tyre choices.

CHALLENGER SPECIFICATIONS

Capacities	Challenger 5M/T 5 seat	Challenger 5A/T 5 seat	LS 5M/T 5 seat	LS 5A/T 5 seat	LS 5A/T 7 seat	XLS 5A/T 5 seat	XLS 5A/T 7 seat
Gross vehicle mass (kg)	2,710	2,710	2,710	2,710	2,710	2,710	2,710
Kerb mass (kg)	2,019	2,029	2,041	2,051	2,106	2,059	2,110
Maximum payload (kg)*	691	681	669	659	609	651	606
Maximum front axle load (kg)*	1,260	1,260	1,260	1,260	1,260	1,260	1,260
Maximum rear axle load (kg)*	1,600	1,600	1,600	1,600	1,600	1,600	1,600
Gross combination mass (kg)	5,650	5,650	5,650	5,650	5,650	5,650	5,650
Towing capacity with trailer brakes (kg)**	3,000	3,000	3,000	3,000	3,000	3,000	3,000
Towing capacity without trailer brakes (kg)	750	750	750	750	750	750	750
Towball download	300	300	300	300	300	300	300
Seating capacity	5	5	5	5	7	5	7

*Payload includes occupants, fuel and fitted options (if any). The weight of these must be deducted from payload to determine actual load carrying capacity. Front and/or rear axle loads must not be exceeded.

** Subject to state regulations and towbar designs

Cargo Area	5 seat	7 seat option
Cargo dimensions (mm)		
Length – 2nd row seats folded	1,572	1,572
Length – 2nd row seats up	1,017	1,017
Length – 2nd row seat folded & 3rd row seat stowed	N/A	1,572
Length – 2nd row seat upright & 3rd row seat stowed	N/A	1,017
Length – 2nd & 3rd row seat upright	N/A	250
Height	1,027	897
Width	1,375	1,375
Load floor height (from ground)	757	839
Cargo load space 2nd row flat (litres)	1,813	N/A
Cargo load space 2nd/3rd row flat (litres)	N/A	1,649
Cargo load space 3rd row flat (litres)	N/A	866

Interior Dimensions (mm)	5 seat	7 seat
Headroom		
Front row	920	920
2nd row	865	865
3rd row	–	819
Legroom		
Front row	915	915
2nd row	840	840
3rd row	–	830
Steering		
Type	Power assisted rack and pinion steering	
Turning Circle (m)	11.2m	

Exterior Dimensions	Challenger	LS/XLS
Overall height (mm)	1,800	1,840
Overall length (mm)	4,695	4,695
Overall width (mm)	1,815	1,815
Ground clearance (mm)	220	220
Track – front (mm)	1,520	1,520
Track – rear (mm)	1,515	1,515
Wheelbase (mm)	2,800	2,800
Approach angle [degrees]	36	36
Departure angle [degrees]	25	25
Ramp breakover angle [degrees]	23	23

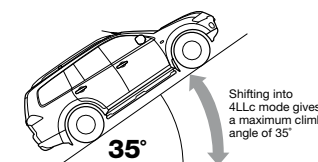
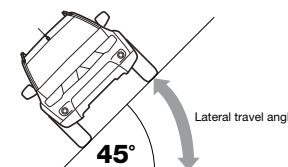
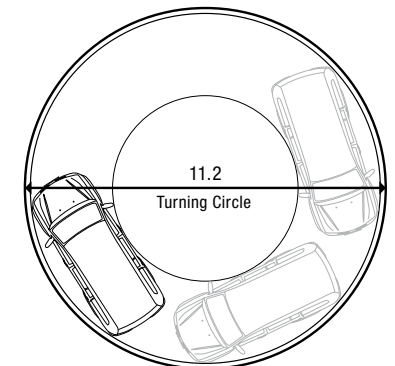
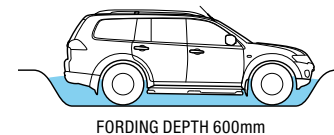
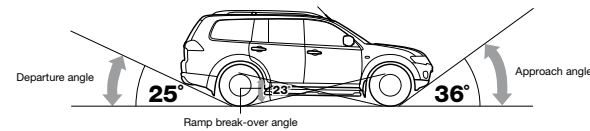
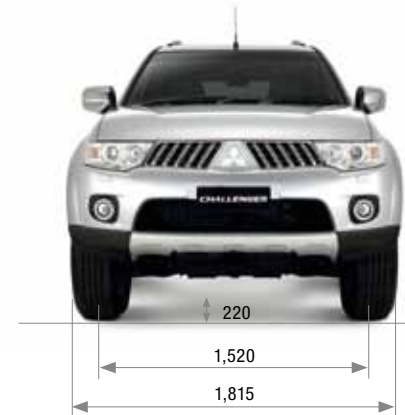

STYLE YOUR CHALLENGER

Colours



CHARCOAL (M)*



COOL SILVER (M)*



IRONBARK (M)**



TERRA ROSSA (M)



CHAMPAGNE (M)



DEEP BLUE (P)*



WHITE*



BLACK (P)

Interiors



CLOTH SEAT TRIM (CHALLENGER, LS)



LEATHER SEAT TRIM (XLS)



TAN LEATHER SEAT TRIM (XLS)

METALLIC (M) AND PEARLESCENT (P) PAINTS ARE OPTIONAL EXTRAS

* NOT AVAILABLE WITH TAN LEATHER SEAT TRIM

** AVAILABLE ON LS & XLS MODELS ONLY

10 **MITSUBISHI**
DIAMOND
ADVANTAGE **5**
AUSTRALIA'S BEST
NEW CAR WARRANTY:
CAPPED PRICE SERVICING
AND CUSTOMER CARE
YEAR YEAR

NOW INCLUDING CAPPED PRICE SERVICING*
WARRANTY 10/5 YEAR ♦ **5 YEAR ROADSIDE ASSIST** ♦ **CUSTOMER ASSIST 24/7** ♦ **200+ DEALER NETWORK**
♦ **GENUINE SERVICE** ♦ **GENUINE PARTS** ♦ **INSURANCE** ♦ **FINANCE** ♦ **PRE-OWNED VEHICLES**

† 10 year or 160,000km Powertrain Warranty (whichever comes first) (non transferable). * 5 year or 130,000km New Vehicle Warranty (whichever comes first). ^ 5 year or 130,000km Roadside Assist (whichever occurs first). Service conditions apply. † 4 year or 60,000km Capped Price Servicing (whichever comes first) Covers all items specified under the standard 'Maintenance for Normal Operating Conditions' schedule detailed in the Service and Warranty Booklet. Additional service/repair items (if required) are at additional cost. Excludes Government and Rental Fleet Customers. See your Dealer for full details.



Always consult your authorised Mitsubishi Dealer for the latest details on specifications, options, prices, availability and conditions on New Vehicle Warranty. All product illustrations and specifications referred to herein are believed to be correct at the time of publication approval. Subject to any applicable Federal, State or Territory Laws or ordinances, which may apply from time to time, Mitsubishi Motors Australia Limited reserves the right, without notice, or obligation, to discontinue or make changes to designs, specifications, colours and materials of the options and products referred to herein at any time without incurring any liability to any purchaser thereof. ©Mitsubishi Motors Australia Limited. ABN 53 007 870 395. scha1101. MIT4022. 11MY – January 2011

CHALLENGER

GENUINE ACCESSORIES



love that car



PERSONALISE YOUR VEHICLE

From the alloy nudge bar to the rear spoiler, Mitsubishi has the accessories to suit your individual needs. Ask your Mitsubishi dealer for the complete list of accessories available for your new Challenger.

Mitsubishi Genuine Accessories go through an extensive program of design, development and testing to ensure they meet all applicable government standards as well as Mitsubishi's own rigorous engineering specifications and performance targets. Using Mitsubishi Genuine Accessories will ensure you get the best quality accessories that are both as durable and reliable as you should expect.



Headlamp Protectors



Tie Down Straps



Bonnet Protector – Clear or Tinted



Front Air Dam



Front Protection Bar – Steel



Front Protection Bar – Alloy



Nudge Bar



Driving Lights



Fog Lamps



Rear Park Assist Sensors



Towbar Garnish



Rear Air Dam



Rear Garnish



Rear Dust Deflector – Acrylic



Roof Rail Cross Bars



Tow Ball



Luggage Pod



Tail Light Garnish



Rear Spoiler



Weathershields

INTERIOR



Front Seat Covers – Neoprene



Rear Seat Covers – Neoprene



Cargo Barrier – Rear Position only



Outer Scuff Plate with Illumination



Outer Scuff Plate – Stainless Steel



Cargo Liner – Plastic (7 seat)



Reversing Mirror/Camera



Cargo Liner – Plastic (5 seat)



Cargo Mat (5 seat)



Non Slip Boot Grip Mat



Luggage Net



Boot Flap Scuff Guard



Carpet Mats (7 seat also available)



Cargo Mat (7 seat)

When Genuine Accessories are fitted to your new vehicle at the time of delivery, they are covered by the Mitsubishi 3 year/130,000km (whichever comes first) Accessory Warranty. When they are fitted after purchase of your new vehicle they are covered for the remainder of the Accessory Warranty or 12 months/20,000km, whichever is longer. In the case of Diamond Spectrum Accessories the warranty is 12 months/20,000km (whichever comes first). Pictures shown for illustration purposes and may not be product specific. Please check with your Mitsubishi dealer for specific model applications. aca1101. MIT4031. 11MY – July 2010