



MX-5



Mazda6



Mazda3



BT-50



Mazda2



CX-9



CX-5

Mazda CX-5  
zoom-zoom  
zoom-zoom



zoom-zoom  
zoom-zoom



mazda

It's an SUV, but not as you know it

Mazda CX-5 is a game changer

SKYACTIV TECHNOLOGY maximises performance, yet minimises fuel consumption

'KODO' styling captures the energy of motion

Giving you more of the driving enjoyment we call Zoom-Zoom



zoom-zoom  
zoom-zoom  
zoom-zoom

# 魂動

KODO : SOUL of MOTION



## GET READY TO SEE THE SUV DIFFERENTLY

Mazda CX-5 is the SUV, created from a different perspective. Sculpted, commanding and dynamic, it certainly hasn't been shaped by compromise. It's the result of our design inspiration, 'KODO - Soul of Motion'. KODO's powerful, athletic

cues capture the muscular beauty of an animal springing into motion. The energetic leap of a cheetah is reflected in Mazda CX-5. With elegant lines, graceful details and a well-planted footprint, it stands proudly apart from other SUVs.

## *SINCE WHEN DID AN SUV DRIVE LIKE THIS?*

Drive Mazda CX-5, and you'll never go back to an ordinary SUV. Its agility and performance make it feel more like a sports car. How? It features the full suite of our SKYACTIV TECHNOLOGY, which redefines every aspect of performance.

Spirited petrol or turbocharged diesel engines use many breakthrough innovations to release maximum power, while achieving fuel economy that matches, or even betters, most small cars. They're eagerly assisted by completely redesigned, low-friction 6-speed transmissions that are

lighter and smaller to boost efficiency. Both manual and automatic gearboxes shift with smooth precision.

In the search for more Zoom-Zoom enjoyment, we've been relentless. Wide-ranging weight savings combine with painstaking optimisation of the body, chassis and suspension. Where other SUVs can feel sluggish and clumsy, you'll enjoy keen acceleration, inertia-free steering and light-footed handling. And the fun comes in front-wheel drive, or gripping all-wheel drive. Even Mazda CX-5's shape makes it hard to

keep up with - detailed airflow management reducing drag, yet heightening stability.

Of course, it has the same sports car DNA that lives in every Mazda. Independent suspension handles corners with instinctive poise, yet also rides luxuriously. Big disc brakes all round ensure confidence-inspiring braking. You've never been able to balance practicality with such grin inducing fun.



**PERFORMANCE LIKE  
YOU'VE NEVER KNOWN**

At Mazda, we believe driving should always be fun. But at the same time we're committed to reducing the environmental impact of our cars. Meeting this challenge required a groundbreaking approach - and it's called SKYACTIV TECHNOLOGY. Put simply, we've re-engineered every aspect of Mazda CX-5 to unleash greater efficiency and more driving enjoyment than any SUV has ever offered.

Engines create more power, yet use less fuel. Transmissions have less friction and are smaller and lighter. High tensile metals dramatically cut body weight to improve handling and economy, but safety isn't compromised. Closely optimised aerodynamics boost efficiency and performance.

Our clever i-stop system puts you further ahead, even at a standstill. Come to a halt and it turns off the engine to further save fuel. The engine is perfectly positioned to leap back to life as you move off, so restarting takes much less time than conventional systems. As you enjoy Zoom-Zoom performance that leads the class, you'll also grin at using as little as 5.1 litres of fuel per 100 kilometres<sup>8</sup> on an extra urban cycle.



AKERA IN BLUE REFLEX MICA



**SKYACTIV-G**

New-generation petrol and diesel power plants represent a fundamental rethink of the internal combustion engine, releasing more performance from less fuel. In the SKYACTIV-G petrol engines the precise direct injection's multi-hole system minimises fuel use. A unique piston design helps achieve more efficient combustion of the fuel and air mix - boosting power and lowering emissions. A major reduction of internal friction liberates extra free-revving power, while a free-breathing 4-2-1 exhaust layout enhances efficiency. The 2.0 litre 4-cylinder engine delivers a sporty 114kW of power and 200Nm of torque, using only 6.4 litres of fuel every 100km<sup>9</sup>. The muscular 2.5 litre engine punches out 138kW and 250Nm, yet uses just 7.4 litres of fuel per 100km<sup>9</sup>.

2.5 litre engine shown.



**SKYACTIV-D**

A significantly lower compression ratio than conventional diesel engines allows for far lighter internal components. This reduces friction and inertia, enabling much higher-revving, more exciting power - right up to 5,200rpm. Multi-hole piezo injectors and variable valve lift combine to optimise engine breathing and economy. The 2.2 litre 4-cylinder engine produces 129kW and a muscular 420Nm of torque, using just 5.7 litres of fuel per 100km<sup>9</sup>. With a two-stage turbocharger maximising power and efficiency, the SKYACTIV-D engine is able to meet strict Euro stage IV emissions standards without the need for expensive after treatment of exhaust gases.



**SKYACTIV-DRIVE**

We've maximised driving fun, and efficiency, by combining the best attributes of conventional automatic, continuously variable and dual clutch transmissions. The SKYACTIV-Drive transmission locks up to couple directly with the engine over a far wider range than other automatics. This delivers a significant improvement in fuel economy and a more direct, manual-like power delivery and driving feel. Shifts are quick, accurate and smooth across the six speeds.

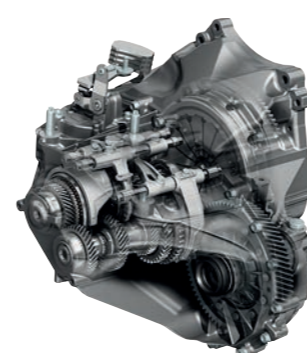

**SKYACTIV-MT**

We wanted a manual transmission that gives you the light, crisp shifting feel of a sports car, just like our iconic Mazda MX-5. Simplified internal design, plus close attention to the shift mechanism, has delivered this sporting feel. The SKYACTIV-MT is much more compact and much lighter than comparable manual transmissions. Match this with a significant reduction in friction and fuel economy is much improved.



**SKYACTIV-BODY**

New-generation design and technologies take performance to unmatched levels. The underbody employs straight-frame construction, which runs uninterrupted through the framework to boost stiffness while saving weight. Front and rear suspension mounting points bond directly to the underbody to add further strength. Greatly increased use of high and ultra-high tensile steel throughout cuts weight, yet bolsters rigidity. Even the doors use special pressing methods to reduce weight without compromising strength. Despite being light, Mazda CX-5 disperses crash energy in multiple directions to achieve collision performance among the world's best.



**SKYACTIV-CHASSIS**

From the ground up we've redesigned every component to create an SUV with an unrivalled sense of 'oneness' between car and driver. To achieve nimble handling with great ride comfort, the chassis uses firmer bushings and completely revised geometry for better bump absorption. A highly rigid front suspension cross member combines with higher-ratio electric power assist steering to quicken handling. Both front and rear cross members offer improved stiffness with much lower weight, thanks to an innovative welding method. It all gives Mazda CX-5 agility you'd never expect in an SUV.

## WHO SAYS AN SUV CAN'T FEEL SPECIAL?

From sophisticated, driver-oriented sports instrumentation, to pressing a button to start up, Mazda CX-5 takes your drive beyond the ordinary. Steering wheel-mounted controls put you in charge of audio, cruise control and Bluetooth® functions. A 5.8 inch touch activated screen automatically links you to the standard reverse camera, and incorporates a multi information display showing Bluetooth® and audio settings. From Maxx Sport up, you've got TomTom sat nav assisting you with features like spoken street names and advanced lane guidance.

What about some music? The USB, Bluetooth® compatible audio system with CD player works in powerful harmony with 4 speakers. Maxx Sport chimes in with 6 speakers, while Grand Touring and Akera deliver concert quality through 231 watt Bose® premium audio and 9 speakers. Naturally, air conditioning is standard - dual-zone climate control giving you customised comfort from Maxx Sport up.

In fact, there's all the technology you'd expect from a class-leader. Power windows and mirrors are included while Maxx Sport adds auto headlamps and rain-sensing wipers. Grand Touring and Akera set an enviable standard with parking sensors, auto-dimming rear-view mirror and the ease of smart keyless entry. The advanced safety of Smart City Brake Support (SCBS) and Blind Spot Monitoring (BSM) is optional on Maxx Sport, standard on Akera. Add Lane Departure Warning (LDW) and High Beam Control (HBC), and Akera puts you right on the cutting edge.

MP3 WMA Bluetooth® BOSE® Navigation by TomTom®



## IT'S WHERE YOU DESERVE TO BE

Sure, the driver gets a cockpit orientated to them, but everyone is made to feel extra special. The spacious, elegant interior accommodates five people and all their gear easily.

Materials that invite the touch combine with meticulous build quality. Look around and you'll find cupholders and storage spaces are integrated thoughtfully. Reminiscent of a sports car, the front seats hug you in comfort. In Grand Touring and Akera, superb black or sand coloured leather<sup>6</sup> seats are set

off by contrasting stitching. What's more, they indulge the driver with 8-way power adjustment and memory function, front passengers with 6-way power adjustment and both front occupants with heating. The luxury continues from Maxx Sport up, with rich leather wrapping the steering wheel and gearshift knob.

Got plenty to do? Good. Even with the rear seats raised, the large cargo area can swallow four big golf bags. And by splitting 60/40 the rear seats help accommodate

large or unusually shaped cargo on a virtually flat floor. Maxx Sport and up brings you a 40/20/40 fold-down arrangement that can be remotely controlled by a luggage bay lever. The middle seat opens up a central tunnel, enabling long items to be carried along with rear passengers. Just as helpful, the 'Karakuri' function allows seat unlatching and folding in one fluid move. Capping it all off is a 'Karakuri' tonneau cover that provides privacy and conveniently moves as one with the tailgate.



**Fully flexible.** Mazda CX-5 offers 40/20/40 split-folding rear seats, operated by a handy remote luggage bay lever. Featured in Maxx Sport and up, they allow the flexibility of a centre tunnel that lets you carry both long objects and two rear passengers. Generous load area is enhanced by a flat floor.



**High style.** Driving position is made even more commanding by driver-orientated design. Premium materials and precision craftsmanship create a refined ambience - all controls operate with smooth, engineered feel. Steering wheel features a classic 3-spoke sports design. Maxx Sport and up integrate TomTom sat nav technology.

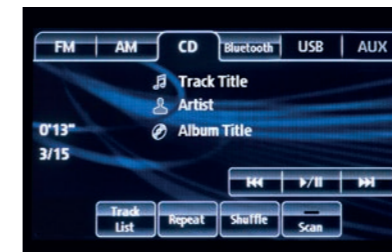

**Need to know.** With touch activated multi information display, you access everything from CD to Bluetooth® audio and hands-free functions on a 5.8 inch screen.



**Simply sporting.** Polished highlights distinguish elegantly finished instrumentation. White illumination enhances legibility. Right hand dial displays fuel level, outside temperature and trip computer information.



**Look, no keys.** Grand Touring and Akera let you jump in without having to fish for keys. As long as you're carrying the remote locking fob, you just enter by pressing a button on either front door. In all models you start up by just hitting the ignition button.



**All covered.** Spacious load area is accessed by easy opening tailgate with integrated 'Karakuri' protective tonneau. It moves in unison with the tailgate for seamless convenience.



**Sound is all round.** In Maxx Sport the MP3/WMA compatible CD player puts on a powerful show through 6 speakers. Grand Touring and Akera plug in the crystal clear quality of a 231 watt Bose® digital amplifier driving 9 speakers (Grand Touring shown).

**You're connected.** With Bluetooth® as standard equipment you've got the ease of hands-free phone calls along with MP3 player connectivity.





## FEEL SAFER THAN EVER BEFORE

With Mazda CX-5, the highest safety standards are on your side. Its extremely rigid body integrates a multi-load path structure to redirect crash energy away from the occupant cell. Also built in are six SRS airbags, including front, side (front) and curtain (front and rear).

In every seat you're reminded to wear your belt - front seat-belts add pretensioners and load-limiters. No matter what the road conditions, you'll feel confident. Dynamic Stability Control (DSC) incorporating Traction Control System (TCS) is standard.



The brakes back you up with large discs all round, ABS and Electronic Brake-force Distribution (EBD), which optimises braking force according to vehicle load. Emergency Brake Assist (EBA) boosts stopping power at just the right time, by monitoring pedal force to recognise emergency braking. Not only that, the Emergency Stop Signal (ESS) automatically flashes the hazard lights to warn the driver behind when you're braking suddenly.

Security? Mazda CX-5 stands guard with remote control locking and an engine immobiliser.

**Safety runs deep.** New-generation SKYACTIV-Body combines lightness with high rigidity. Impact paths are distributed carefully, offering the strongest possible occupant protection. Driver and passenger front and side airbags, plus front and rear curtain airbags are standard equipment.

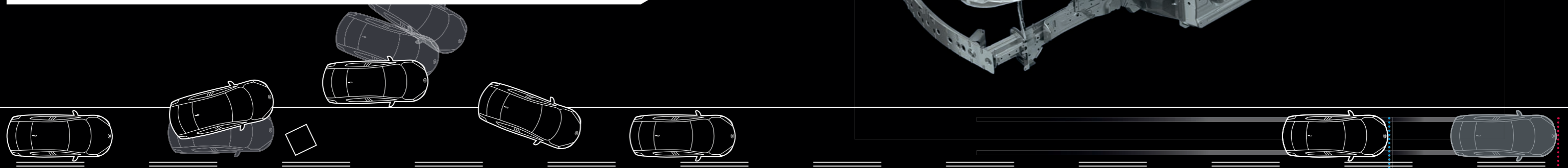

**Prepared for what's ahead.** What if you're faced with a hazard and have to react suddenly? DSC acts instantly, braking the inner rear wheel to counter understeer (or outer front wheel to combat oversteer). The TCS also reduces torque to the driven wheels to minimise slip. As a result, control is maintained and the vehicle can be steered around the hazard.



**Light the way.** Grand Touring and Akera feature Bi-Xenon headlamps. High intensity light casts a longer, broader beam for superior vision. Headlamp washers keep lenses clean.



**Better braking.**  
Stopping distance with EBA, ABS and EBD.

Stopping distance with no assistance.



**Perfect launch.** All models come with Hill Launch Assist (HLA). Remove your foot from the brake on an incline and it keeps the brakes applied for about two seconds, giving you enough time to apply the accelerator for a smooth take-off.

**Peripheral vision.** Grand Touring and Akera feature Adaptive Front-lighting System (AFS). The powerful Bi-Xenon headlamps swivel up to 15 degrees in the direction you're steering, revealing more of the corner.

***i-ACTIVSENSE.  
SAFETY SO ADVANCED,  
IT CAN SENSE  
POTENTIAL TROUBLE***

Mazda CX-5 protects you comprehensively, with an array of world-class safety features built in. And our advanced i-ACTIVSENSE technology heightens your sense of confidence even further.

i-ACTIVSENSE brings together the latest in intelligent safety, including Smart City Brake Support, Blind Spot Monitoring, Lane Departure Warning and High Beam Control. These systems are designed to aid the driver in recognising potential hazards, avoiding collisions and to minimise the severity of accidents when they can't be avoided. Employing sophisticated radar, cameras, and driver warnings, i-ACTIVSENSE literally looks out for you.



AKERA IN SOUL RED METALLIC

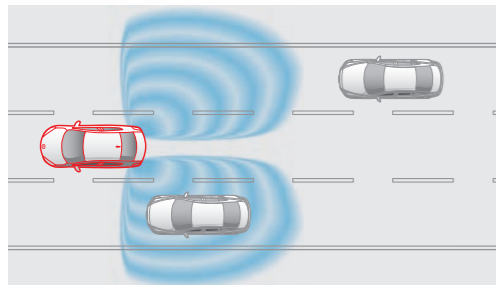

**Blind Spot Monitoring (BSM).**

By scanning external mirrors' blind spots, this innovation warns of any unseen vehicles to help you avoid making hazardous lane changes. LED icon on the relevant mirror is accompanied by warning beeper. Standard on Akera, optional on Maxx Sport.

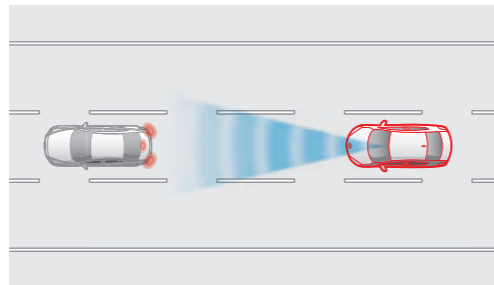

**Smart City Brake Support (SCBS).**

Helps prevent, or lessen, low-speed impacts. At speeds of 4 - 30km/h, SCBS monitors the vehicle in front to assess the possibility of a collision. If the system detects a high risk of impact, it applies initial braking pressure to deliver faster response should the driver brake. If the driver does not brake, the brakes are applied automatically. Standard on Akera, optional on Maxx Sport.

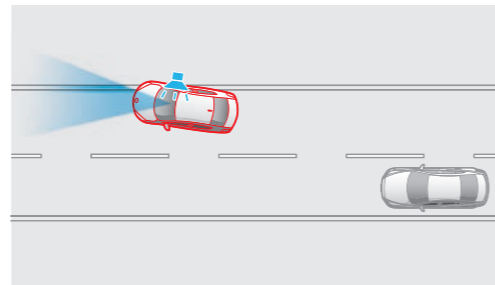

**Lane Departure Warning (LDW).**

Using a windscreen-mounted camera to monitor road lane markings, this system warns you in advance if you're about to stray from your lane, via an audible warning. Akera only.

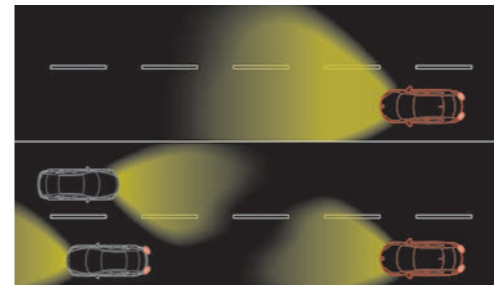

**High Beam Control (HBC).**

Enjoy the enhanced safety of high beam illumination, without having to manually switch to low-beam. A camera detects oncoming cars' headlights, or the taillights of cars in front, and automatically switches to low-beam, then back when it's safe. Also selects low beam in lit areas or at low speed. Akera only.

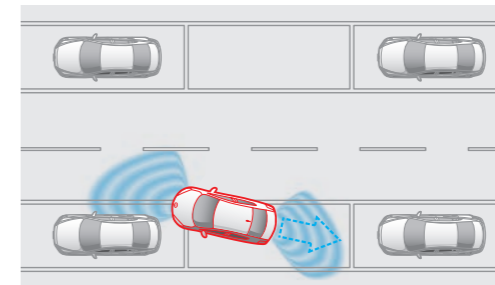

**Parking Sensors.**

Sensors at the front and rear sound audible warnings to make parking easier, and help avoid parking bumps or scratches. Grand Touring and Akera only.



**Tyre Pressure Monitoring System (TPMS).**

Advanced sensors constantly monitor the tyre pressures, warning via audible chime and dash light should they fall below a safe level. Standard on all models.

## CX-5 MAXX

Maxx combines five-seat SUV flexibility with unmatched agility and class-leading fuel economy. All this and dynamic style too.

- 17 inch steel wheels with 225/65 tyres
- Headlamps (Halogen)
- Power mirrors and windows
- Rear spoiler
- Air-conditioning
- Bluetooth® (hands-free compatible)<sup>5</sup>
- Cruise control
- Seat trim: cloth
- Seats (front) with: height adjustment (driver) and seat back pockets
- Seats (rear) with: 60/40 split-fold backrest
- Smart keyless push-button start
- Tilt and telescopic adjustable steering wheel
- Trip computer<sup>7</sup>
- Wipers (front) 2-speed with: variable intermittent function
- Audio system with: AM/FM tuner, single disc CD player (MP3/WMA compatible) and 4 speakers
- Bluetooth® audio (MP3 player compatible)<sup>5</sup>
- USB input (iPod® compatible)
- Airbags SRS: front (driver and passenger), side (front) and curtain (front and rear)
- Anti-lock Braking System (ABS)
- Dynamic Stability Control (DSC)
- Electronic Brake-force Distribution (EBD)
- Emergency Stop Signal (ESS)
- Hill Launch Assist (HLA)
- Reverse camera
- Traction Control System (TCS)
- Tyre Pressure Monitoring System (TPMS)



2.0L Petrol FWD  
Man or Auto



2.5L Petrol AWD  
Auto only



**See it all.** Reverse camera is a great help – view is automatically displayed when you select reverse, making backing up safer and easier.



**Keep connected.** USB input is standard, as is Bluetooth® for hands-free phone calls and wireless audio streaming via MP3 players.<sup>5</sup>



**Press to play.** Getting going always feels special, thanks to the ease of push-button engine starting.



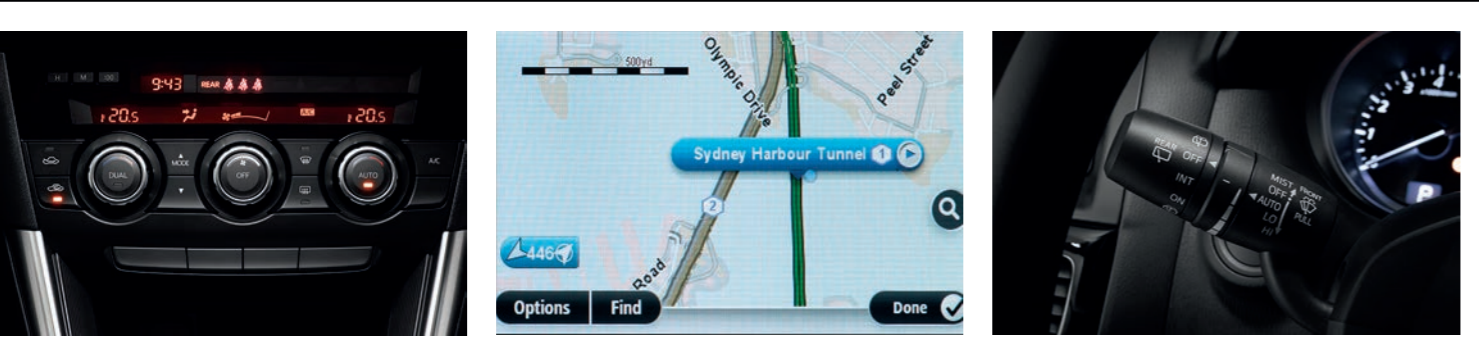

**Perfect climate.** With dual-zone climate control, both driver and passenger can enjoy just the right temperature.

**Right on course.** TomTom based sat nav features on easy to read 5.8 inch colour touch screen.

**It's automatic.** Enhanced safety of rain-sensing wipers and auto headlamps lets you focus on enjoying the drive.

## CX-5 MAXX SPORT

Take the exceptional talents of Mazda CX-5 and add even more. That's Maxx Sport, with enhanced style, technology and features.

Maxx Sport features additional to Maxx include:

- 17 inch alloy wheels
  - Fog-lamps (front)
  - Air-conditioning (dual-zone climate control)
  - Headlamps auto on/off function
  - Leather-wrapped: gear shift knob, handbrake handle and steering wheel
  - Satellite navigation (TomTom)
  - Seats (rear) with: 40/20/40 split-fold backrest (flat fold) and centre fold-down armrest
  - Vanity mirrors (front) with illumination
  - Wipers (front) 2-speed with rain-sensing function
  - Audio system with: 6 speakers
- Safety Pack option includes:
- Blind Spot Monitoring (BSM)
  - Rear-view mirror with auto dimming function
  - Smart City Brake Support (SCBS)



**2.0L Petrol FWD**  
Auto only



**2.5L Petrol AWD**  
Auto only



**2.2L Diesel AWD**  
Auto only



## CX-5 GRAND TOURING

Want your SUV equipped with every possible comfort? Grand Touring has all the appointments to make driving extra special.

Grand Touring features additional to Maxx Sport include:

- 19 inch alloy wheels with 225/55 tyres
- Daytime running lamps
- Headlamps (Bi-Xenon) with Adaptive Front-lighting System (AFS)
- Power sliding and tilt glass sunroof
- Rear-view mirror with auto dimming function
- Seat (driver) with: 8-way power adjustment, 2-position memory function, power lumbar support and heating function
- Seat (passenger) with: 6-way power adjustment and heating function
- Seat trim: leather<sup>6</sup>
- Smart keyless entry
- Audio system with: premium Bose® 231 watt amplifier and 9 speakers
- Parking sensors (front and rear)



2.5L Petrol AWD  
Auto only



2.2L Diesel AWD  
Auto only



GRAND TOURING IN ALUMINIUM METALLIC



## CX-5 AKERA

Supreme comfort and the most advanced safety features are yours. You'll be looked after in every way.

Akera features additional to Grand Touring include:

- Blind Spot Monitoring (BSM)
- High Beam Control (HBC)
- Lane Departure Warning (LDW)
- Smart City Brake Support (SCBS)



2.5L Petrol AWD  
Auto only



2.2L Diesel AWD  
Auto only

AKERA IN CRYSTAL WHITE PEARL MICA

# SPECIFICATIONS

2.0L Petrol FWD

2.5L Petrol AWD

2.2L Diesel AWD

Powertrain		2.0L Petrol FWD	2.5L Petrol AWD	2.2L Diesel AWD
Engine type		2.0 litre in-line 4 cylinder 16 valve DOHC S-VT petrol (SKYACTIV-G) with i-stop	2.5 litre in-line 4 cylinder 16 valve DOHC S-VT petrol (SKYACTIV-G) with i-stop	2.2 litre in-line 4 cylinder 16 valve DOHC intercooled turbo diesel (SKYACTIV-D) with i-stop
Engine capacity		1,998 cc	2,488 cc	2,191 cc
Bore and stroke		83.5 mm x 91.2 mm	89.0 mm x 100.0 mm	86.0 mm x 94.3 mm
Compression ratio		13.0 : 1	13.0 : 1	14.0 : 1
Maximum power		114 kW @ 6,000 rpm	138 kW @ 5,700 rpm	129 kW @ 4,500 rpm
Maximum torque		200 Nm @ 4,000 rpm	250 Nm @ 4,000 rpm	420 Nm @ 2,000 rpm
Throttle control		Electronic (drive-by-wire)	Electronic (drive-by-wire)	Electronic (drive-by-wire)
Fuel system		Electronic direct injection	Electronic direct injection	Common-rail, electronic direct injection
Fuel tank capacity		56 litres	58 litres	58 litres
Recommended fuel		Unleaded (91RON or higher) or E10	Unleaded (91RON or higher) or E10	Diesel
Fuel consumption <sup>1</sup>	man (combined)	6.4 litres per 100 km	-	-
	auto (combined)	6.4 litres per 100 km	7.4 litres per 100km	5.7 litres per 100 km
Emissions standard		Euro stage IV	Euro stage IV	Euro stage IV
Manual (SKYACTIV-MT) transmission		6-speed	-	-
Automatic (SKYACTIV-Drive) transmission		6-speed	6-speed	6-speed
Gear ratio - man/auto	1st	3.700 / 3.552	- / 3.552	- / 3.487
	2nd	1.947 / 2.022	- / 2.022	- / 1.992
	3rd	1.300 / 1.452	- / 1.452	- / 1.449
	4th	1.029 / 1.000	- / 1.000	- / 1.000
	5th	0.837 / 0.708	- / 0.708	- / 0.707
	6th	0.680 / 0.599	- / 0.599	- / 0.600
	reverse	3.724 / 3.893	- / 3.893	- / 3.990
	final drive	4.705 / 4.624	- / 4.325	- / 4.090

Maxx

Maxx Sport

Grand Touring

Akera

Models	Maxx	Maxx Sport	Grand Touring	Akera
2.0L Petrol FWD	Manual or Auto	Auto only	-	-
2.5L Petrol AWD	Auto only	Auto only	Auto only	Auto only
2.2L Diesel AWD	-	Auto only	Auto only	Auto only

Chassis		Maxx	Maxx Sport	Grand Touring	Akera
Brake diameter	front	297 mm	297 mm	297 mm	297 mm
	rear	303 mm	303 mm	303 mm	303 mm
Brake type	front	Ventilated disc	Ventilated disc	Ventilated disc	Ventilated disc
	rear	Solid disc	Solid disc	Solid disc	Solid disc
Steering type		Electronic power assist steering	Electronic power assist steering	Electronic power assist steering	Electronic power assist steering
Suspension type	front	MacPherson strut	MacPherson strut	MacPherson strut	MacPherson strut
	rear	Multi-link	Multi-link	Multi-link	Multi-link
Turning circle	kerb to kerb	11.2 m	11.2 m	11.2 m	11.2 m
Tyre size		225/65 R17	225/65 R17	225/55 R19	225/55R19
Tyre index		102V	102V	99V	99V
Wheel size		17 x 7.0 J	17 x 7.0 J	19 x 7.0 J	19 x 7.0 J
Wheel type		Steel	Alloy	Alloy	Alloy
Tyre size (spare)		185/80 R17	185/80 R17	185/80 R17	185/80R17
Wheel type (spare)		Steel	Steel	Steel	Steel

Maxx

Maxx Sport

Grand Touring

Akera

Weights and capacities		Maxx	Maxx Sport	Grand Touring	Akera
Cargo room	volume (VDA) <sup>2</sup>	403 litres	403 litres	403 litres	403 litres
	volume (VDA) <sup>3</sup>	1,560 litres	1,560 litres	1,560 litres	1,560 litres
Kerb weight	man (2.0L Petrol FWD)	1,443 kg	-	-	-
	auto (2.0L Petrol FWD)	1,475 kg	1,478 kg - 1,479 kg	-	-
	auto (2.5L Petrol AWD)	1,555 kg	1,559 kg - 1,560 kg	1,616 kg	1,618 kg
	auto (2.2L Diesel AWD)	-	1,632 kg - 1,634 kg	1,688 kg	1,690 kg
Tow-ball download	maximum	150 kg	150 kg	150 kg	150 kg
Towing capacity <sup>4</sup>	braked	1,800 kg	1,800 kg	1,800 kg	1,800 kg
	unbraked	750 kg	750 kg	750 kg	750 kg

Dimensions		Maxx	Maxx Sport	Grand Touring	Akera
Ground clearance	laden	150 mm	150 mm	150 mm	150 mm
Overall length		4,540 mm	4,540 mm	4,540 mm	4,540 mm
Overall width		1,840 mm	1,840 mm	1,840 mm	1,840 mm
Overall height		1,710 mm	1,710 mm	1,710 mm	1,710 mm
Track	front	1,585 mm	1,585 mm	1,585 mm	1,585 mm
	rear	1,590 mm	1,590 mm	1,590 mm	1,590 mm
Wheelbase		2,700 mm	2,700 mm	2,700 mm	2,700 mm

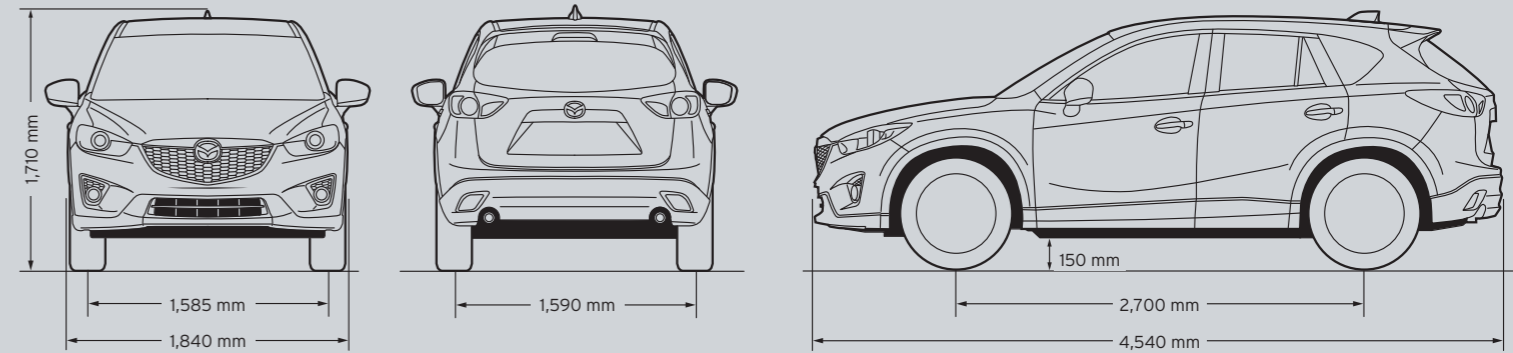

Exterior	Maxx	Maxx Sport	Grand Touring	Akera
Daytime running lamps	-	-	●	●
Door handles (body coloured)	●	●	●	●
Exhaust extensions (chrome)	●	●	●	●
Fog-lamps (front)	-	●	●	●
Front and rear bumpers (body coloured)	●	●	●	●
Green-tinted windscreen, side and rear windows	●	●	●	●
Headlamps (Bi-Xenon) with Adaptive Front-lighting System (AFS)	-	-	●	●
Headlamps (Halogen)	●	●	-	-
Power mirrors (body coloured)	●	●	●	●
Power sliding and tilt glass sunroof	-	-	●	●
Power windows	●	●	●	●
Rear spoiler	●	●	●	●
Roof rack mounting points	●	●	●	●

● Standard Feature - Not Available

# SPECIFICATIONS

Maxx

Maxx Sport

Grand Touring

Akera

## Interior

Air-conditioning	●	-	-	-
Air-conditioning (dual-zone climate control)	-	●	●	●
Ambient temperature display	●	●	●	●
Bluetooth® (hands-free compatible) <sup>5</sup>	●	●	●	●
Cargo area 12 volt power outlet	●	●	●	●
Cargo area tonneau cover with 'Karakuri' up and down function	●	●	●	●
Centre armrest console with tray	●	●	●	●
Critical function warning lights/chimes	●	●	●	●
Cruise control	●	●	●	●
Cupholders	●	●	●	●
Door pockets (front and rear)	●	●	●	●
Glove box	●	●	●	●
Headlamps auto on/off function	-	●	●	●
Illuminated entry system with delayed fade	●	●	●	●
Instrument panel light dimmer	●	●	●	●
Interior illumination:				
cargo room lamp	●	●	●	●
map reading spot lamps	●	●	●	●
power window switch (driver)	●	●	●	●
Interior release for:				
fuel filler door	●	●	●	●
Leather-wrapped:				
gear shift knob	-	●	●	●
handbrake handle	-	●	●	●
steering wheel	-	●	●	●
Overhead sunglass storage box	●	●	●	●
Rear-view mirror with auto dimming function	-	○	●	●
Satellite navigation (TomTom)	-	●	●	●
Seat trim:				
cloth	●	●	-	-
leather <sup>6</sup>	-	-	●	●
Seats (front) with:				
8-way power adjustment (driver)	-	-	●	●
6-way power adjustment (passenger)	-	-	●	●
2-position memory function (driver)	-	-	●	●
adjustable head restraints	●	●	●	●
heating function	-	-	●	●
height adjustment	●	●	●	●
power lumbar support (driver)	-	-	●	●
rake and slide adjustment	●	●	●	●
seat back pockets	●	●	●	●
Seats (rear) with:				
40/20/40 split-fold backrest (flat fold)	-	●	●	●
60/40 split-fold backrest	●	-	-	-
adjustable head restraints	●	●	●	●
centre fold-down armrest	-	●	●	●
Smart keyless entry	-	-	●	●
Smart keyless push-button engine start	●	●	●	●
Tachometer and electronic odometer/tripmeter	●	●	●	●
Tilt and telescopic adjustable steering wheel	●	●	●	●
Trip computer <sup>7</sup>	●	●	●	●
Vanity mirrors (front)	●	-	-	-
Vanity mirrors (front) with illumination	-	●	●	●
Window demister (rear)	●	●	●	●

Maxx

Maxx Sport

Grand Touring

Akera

## Interior (continued)

Wipers (front) 2-speed with rain-sensing function	-	●	●	●
Wipers (front) 2-speed with variable intermittent function	●	-	-	-
Wiper (rear) with intermittent function	●	●	●	●

## Audio

AM/FM tuner	●	●	●	●
Auxiliary input (3.5mm MP3 player compatible)	●	●	●	●
Bluetooth® audio (MP3 player compatible) <sup>5</sup>	●	●	●	●
CD player, single disc (MP3/WMA compatible)	●	●	●	●
Premium Bose® 231 watt amplifier and speakers	-	-	●	●
Speakers (4)	●	-	-	-
Speakers (6)	-	●	-	-
Speakers (9)	-	-	●	●
Steering wheel-mounted audio controls	●	●	●	●
USB input (iPod® compatible)	●	●	●	●

## Safety

Airbags SRS:				
front (driver and passenger)	●	●	●	●
side (front)	●	●	●	●
curtain (front and rear)	●	●	●	●
Anti-lock Braking System (ABS)	●	●	●	●
Blind Spot Monitoring (BSM)	-	○	-	●
Child restraint anchor points	●	●	●	●
Dynamic Stability Control (DSC)	●	●	●	●
Electronic Brake-force Distribution (EBD)	●	●	●	●
Emergency Brake Assist (EBA)	●	●	●	●
Emergency Stop Signal (ESS)	●	●	●	●
Engine immobiliser	●	●	●	●
High Beam Control (HBC)	-	-	-	●
High mount stop lamp	●	●	●	●
Hill Launch Assist (HLA)	●	●	●	●
Lane Departure Warning (LDW)	-	-	-	●
Left-hand-side convex (wide angle) exterior mirror	●	●	●	●
One touch (up and down) power window (driver)	●	●	●	●
Parking sensors (front and rear)	-	-	●	●
Remote central locking (2 transmitters)	●	●	●	●
Reverse camera	●	●	●	●
Seat-belt warning (front and rear)	●	●	●	●
Seat-belts 3-point lap-sash (all seats)	●	●	●	●
Seat-belts (front) with pretensioners, load-limiters and height adjustable shoulder anchorages	●	●	●	●
Side impact door beams	●	●	●	●
Smart City Brake Support (SCBS)	-	○	-	●
Traction Control System (TCS) - switchable on/off	●	●	●	●
'Triple H' safety construction with front and rear crumple zones	●	●	●	●
Tyre Pressure Monitoring System (TPMS)	●	●	●	●
Whiplash-minimising front seats	●	●	●	●

● Standard Feature ○ Option - Not Available



**'KODO - SOUL OF MOTION'  
MOVES ZOOM-ZOOM DESIGN AHEAD**

We're taking the driving excitement that is Zoom-Zoom, and giving it strong expression in the design of Mazda models. We call this bold new design direction 'KODO - Soul of Motion'. It's inspired by the moment pent up energy is suddenly released to become motion. The sculpted forms that characterise our latest vehicles capture the power and beauty of an animal pouncing, or an athlete launching into action. Detailed craftsmanship achieves a sense of simplicity and sophistication. At once alluring and dynamic, KODO is yet another way Mazda maximises driver enjoyment. Discover more at [mazda.com.au/design](http://mazda.com.au/design)

**Driving enjoyment has an exciting future**

We're working hard to make driving a Mazda even more exciting. With cars that use less fuel, but produce more power. That are lighter, but contain more innovation. We call this breakthrough SKYACTIV TECHNOLOGY. It will let every Mazda deliver more driving pleasure while being kinder to the planet. Discover more at [mazdafuture.com](http://mazdafuture.com)

**Rest assured - your warranty**

The quality built into Mazda CX-5 is backed up by a 3-year, unlimited kilometre factory warranty and 6-year panel protection warranty.



**Maintain that Zoom-Zoom**

Your Mazda CX-5 deserves the best in care. Servicing through the Mazda Maintenance Program gives your car the advantage of factory trained Service Technicians and advanced computer diagnostic systems. As well as maintaining your Mazda in A1 condition, you'll also be protecting your vehicle's outstanding resale value.

**Help is at hand - Mazda Roadside Assistance**

Flat batteries, running out of fuel, flat tyres - everyone faces hiccups from time to time. When the unexpected happens, Mazda Roadside Assistance is there to keep you moving. You'll be covered 24 hours a day, 365 days a year, all round Australia. Better still, your Mazda will only be worked on by Mazda-approved technicians.

Choose a Standard policy offering everything needed to get going again, or Premium with extras like accommodation, a rental car and vehicle recovery. Either can be purchased across the entire Mazda range. (Terms and conditions apply.)

**Accessories add enjoyment**

Mazda CX-5 gives you spirited performance and great features. And with Mazda Genuine Accessories, Mazda CX-5 ownership is even more enjoyable. They allow you to personalise your car, and protect your investment. What's more, they deliver superb design, quality and safety, all backed by a Mazda Genuine Warranty. Mazda Genuine Accessories give you even more Zoom-Zoom.

For further information visit [mazda.com.au](http://mazda.com.au) or Freecall 1800 034 411



Like us on the official Mazda Australia fan page for the latest pictures, videos, events, news and competitions. Ask questions, give feedback or upload your own photos. Join the conversation at [facebook.com/mazdaaus](http://facebook.com/mazdaaus)



Join the conversation on Twitter. Keep up with breaking Mazda news, videos and pictures from around the web. Tweet your questions, give feedback or post your own photos. [twitter.com/mazdaaus](http://twitter.com/mazdaaus)



Visit Mazda Australia's YouTube channel. You'll find video content with exclusive behind-the-scenes footage. [youtube.com/zoomzoom](http://youtube.com/zoomzoom)

**COLOURS**

**Exterior**



Crystal White Pearl  
Mica



Aluminium  
Metallic



Blue Reflex  
Mica



Soul Red  
Metallic



Zeal Red ■  
Mica



Meteor Grey ■  
Mica



Deep Crystal Blue ■  
Mica



Jet Black ■  
Mica

**Interior**

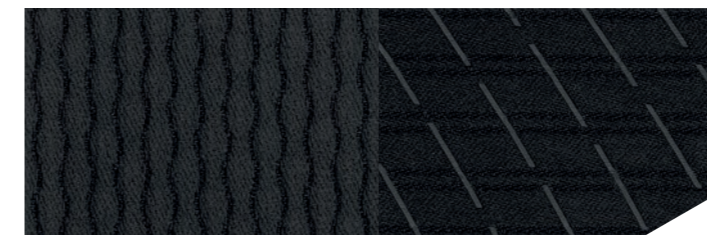

Black Cloth  
Maxx

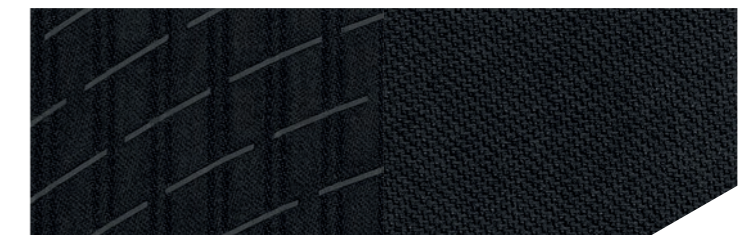

Black Cloth  
Maxx Sport

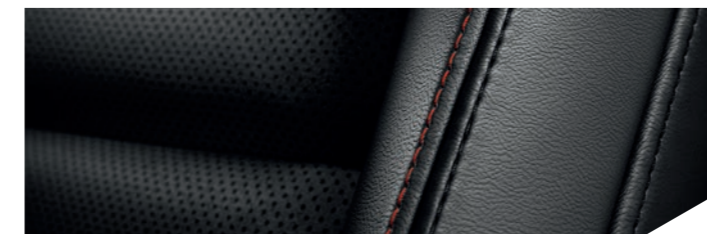

Black Leather<sup>6</sup>  
Grand Touring and Akera



Sand Leather<sup>6</sup> ■  
Grand Touring and Akera

1 Fuel consumption figures are based on ADR 81/02. They are useful in comparing the fuel consumption of different vehicles. They may not be the fuel consumption achieved in practice. This will depend on traffic, road conditions and how the vehicle is driven. 2 Measured with rear seats up and up to tonneau cover. 3 Measured with rear seats folded down and up to roof. 4 Subject to State or Territory regulations. 5 Please check the compatibility of your Bluetooth® device (particularly your mobile phone) with the specific Mazda vehicle you intend to purchase as not all devices operate correctly. Visit [mazdahandsfree.com.au](http://mazdahandsfree.com.au) or consult your Mazda Dealer for further information. 6 Leather interior includes Maztex material on selected high impact surfaces. Sand leather interior only available with selected exterior colours. 7 Trip computer displays current and average fuel consumption, distance to empty and average vehicle speed. 8 Mazda CX-5 2.2L Diesel AWD, extra urban fuel consumption figure as per ADR 81/02. 9 Combined fuel consumption figure as per ADR 81/02 test results.