

HYUNDAI | NEW THINKING.
NEW POSSIBILITIES.

iLoad Series II



Hello.

Welcome to Hyundai.

If you're new to us, we'd like to introduce you to a company which has become the world's fastest growing automotive brand.

We are obsessed with making visionary cars that are great to own and fun to drive. Our focus on the latest technology, the best safety features, and the highest quality engineering is the reason why so many people now choose Hyundai.

Each new Hyundai vehicle is the product of new thinking – of looking afresh and questioning the way things have been done in the past. And from new thinking comes new possibilities.

Enjoy the drive.

A lasting relationship with Hyundai iCare.

Owning a car should be an enjoyable, stress-free experience with service that doesn't end in the showroom. That's why every new Hyundai comes with iCare. For years now, Hyundai has been the market leader in customer care and after sales support. To put it simply, we're with you for the road ahead.

A warranty that goes the distance

Five years. 160,000 kilometres! It's a warranty idea that shows the belief we have in the manufacturing, quality, control, and design that's gone into your vehicle.

No unpleasant service cost surprises

With our Lifetime Service Plan², you'll always know the price of your next service before you pull into the service centre.

Should the unexpected happen, we'll be there

It's unlikely you'll run into problems while on the road. But if you do, it's nice to know that with our 24/7 Roadside Support Plan³ there's always someone on standby to get you up and running again.



iLoad Series II van shown in Creamy White



- 5 year/160,000km warranty:** For ultimate peace of mind, each Hyundai commercial use vehicle is backed by an impressive 5 year/160,000km warranty, whichever comes first.
- Lifetime Service Plan:** For the benefit of Hyundai owners, Hyundai provides online quotes, which specify the maximum price applicable for a vehicle's next scheduled maintenance service at a participating authorised Hyundai Dealer and using genuine Hyundai parts (where required). Online quotes are available at www.hyundai.com.au and apply for a stated effective period only and may change without notice after that effective period. Standard scheduled maintenance services are of limited scope. The benefit of online quotes is available for all Hyundai vehicles for their lifetime.
- Roadside Support Plan:** Complimentary 12 months Roadside Support when you purchase a new Hyundai passenger vehicle (excluding rental buyers). Further Roadside Support extensions are available, each for 12 months from the date of a scheduled maintenance service at a participating authorised Hyundai Dealer (unless vehicle is more than 108 months [9 years] from the original new car sale date, in which case entitlement to Roadside Support ends when vehicle reaches 120 months [10 years] from original new car sale date).

iLoad Series II

A tough new contender

With a choice of the 3-seater van or 6-seater crew van with cargo compartment, Hyundai has created a highly-functional commercial vehicle that's as versatile and accommodating as it is robust and reliable.

The iLoad Series II combines effortless practicality and precision engineering with advanced safety technology and enviable fuel economy in a mobile workplace that won't let you down. You can also select from a range of Hyundai Genuine Accessories to customise your iLoad Series II.

Load up your business...with the iLoad Series II



The iLoad Series II van and crew van set a new benchmark in commercial flexibility, passenger & cargo functionality, performance & reliability.



When size matters...
iLoad Series II
delivers
the goods.

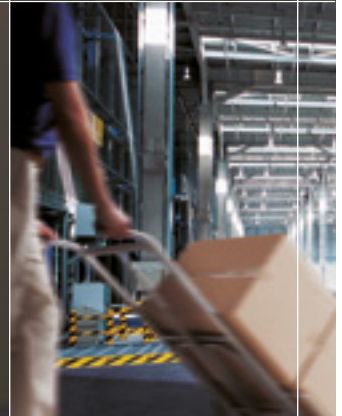

Room to Move

For operators requiring maximum carrying capacity, the 3 seater iLoad Series II van boasts plenty of usable cargo space (2.37m long, 1.62m wide and 1.34m high) large enough for two pallets, with a practical vinyl-covered flat floor.

Van functionality includes two sliding side doors as standard plus rear lift gate or optional twin swing doors (Diesel only) for easy access, along with a centre seat that converts to additional storage when not needed for a third passenger.

For those wanting even more passenger space, the iLoad Series II crew van provides seating for up to six people whilst retaining a generous cargo compartment with plenty of room for a pallet or delivery items.

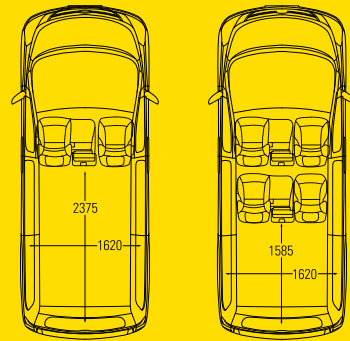

van

crew van

Space



Big on Safety

From the robust chassis and superior braking to the dual front and side airbag system and seatbelt pretensioners, the iLoad Series II has active and passive safety features that further demonstrate Hyundai's commitment to driver, passenger and cargo protection at all times.



- 4-Star ANCAP safety rating
- Rear view camera*
- 4 channel Anti-lock Braking System (ABS) with Electronic Brakeforce Distribution (EBD) and 4 wheel disc brakes
- Electronic Stability Control (ESC) and Traction Control System (TCS) with CRDi models
- Dual front and side airbags and height-adjustable front seatbelts with pretensioners
- Keyless entry + immobiliser + security alarm + central locking
- Semi-bonnet design
- Four-ring strengthened body with rigid cabin
- Impact absorbing crush zones front and rear

Protecting lives and your livelihood

4 ring construction

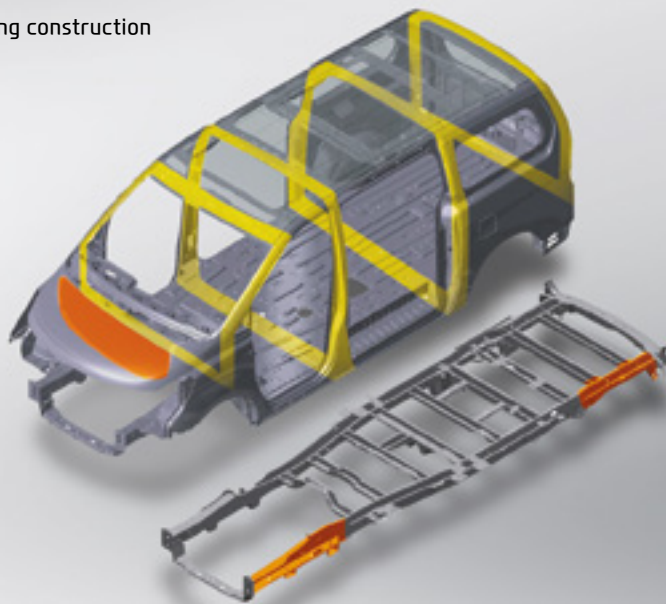

*Not available with twin swing doors.



Dual front and side airbags



Shown with optional twin swing doors - 180° access

Cabin Comfort

No matter what your task, you can do it in complete comfort in iLoad Series II. You'll now enjoy a 7" touchscreen audio system with iPod® compatibility,^ reverse camera* and Siri® Eyes Free (iOS) and Google Now (Android) voice activation. All contained within a spacious, ergonomic cabin which also features air conditioning, power steering, power windows and mirrors, and a handy cup holder.

The tilt steering column and front console-mounted gearshift further emphasise the modern, functional layout and provide easier movement between driver and front passengers, and the high seating position, oversized windscreen and large door mirrors deliver optimum visibility. The driver's seat is height adjustable, the steering wheel can be tilted and there are even easy to reach grab handles to make entering and exiting a breeze. For cabin security, we offer you a folding key, with separate lock and unlock remote buttons.



Overseas model shown



Bluetooth® is a registered trademark of Bluetooth SIG, Inc. #Please check your Bluetooth® device's capabilities to ensure compatibility. iPod® and Siri® are registered trademarks of Apple Inc., registered in the US and other countries. ^iPod® and connection lead not included. *Not available with twin swing doors.



iLoad Series II crew van interior

Diesel model shown



Power

2.5 CRDi Diesel

- Power = 100kW (manual), 125kW (auto)
- Torque = 343Nm (manual), 441Nm (auto)
- Fuel Economy = 8 litres* (manual) per 100km
8.8 litres* (auto) per 100km
- Common Rail Direct injection (CRDi) Diesel fuel delivery system with Variable Geometry Turbo (VGT) on automatic transmission or Wastegate Turbocharger (WGT) on manual

Towing Capacity:

Diesel manual – 2000kg (braked)
– 750kg (unbraked)

Diesel auto – 1500kg (braked)
– 750kg (unbraked)

2.4 MPI petrol

- Power = 127kW
- Torque = 224Nm
- Fuel Economy = 10.1 litres* (manual) per 100km
- Sequential multi-point fuel injection (MPI) with a tuned intake system

Towing Capacity:

Petrol manual – 1500kg (braked)
– 750kg (unbraked)

*Australian Design Rule 81/02 static laboratory combined average city & highway cycle test. Fuel consumption will vary depending on a combination of driving habits and the condition of the vehicle.

Packaged to Perform

Engineered to handle the heaviest of loads, the iLoad Series II van tackles the most arduous of conditions with ease.

Macpherson Strut front suspension and heavy duty leaf spring rear suspension is positioned for optimal load-bearing, the 4-channel Anti-lock Braking System (ABS) acts on front and rear discs with a 10" booster for exceptional stopping power; and the Electronic Stability Control (ESC)[^] with Traction Control System (TCS)* work together to monitor engine response and help control wheel slippage in hazardous braking circumstances.

The 2.4 petrol or high output 2.5 Diesel engines deliver outstanding power and torque, while advanced technology ensures enviable economy and dependability. The 5-speed manual is available with the 2.4 MPi petrol engine, whilst our 2.5 Diesel engine offers a 6-speed manual or 5-speed automatic transmission.



2.5 CRDi turbo Diesel



2.4 MPi petrol

[^]Not available on petrol engine.

Hyundai Genuine Accessories

Hyundai Genuine Accessories can enhance your driving pleasure and ownership pride by adding extra ease and enjoyment to your lifestyle pursuits.

All Hyundai Genuine Accessories are backed by a 5 year warranty if purchased at the time of a new Hyundai vehicle and fitted by an authorised Hyundai dealer.*



Tailored Rubber Floor Mats



Dash Mat



Rubber Cargo Mat



Courier's Wooden Floor



Cargo Barrier



Headlight Protectors



Tinted Stylevisors

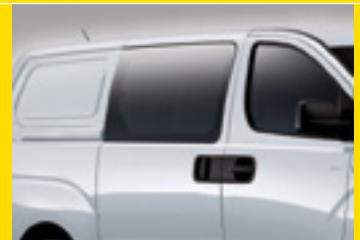

Sliding Door Windows



Towbar & Towball and Trailer Wiring Harness¹



Rear Step with Corner Protectors



Technician Step with Grab Handles



Grab Handles



Full Technician Kit²



Rear Park Assist³

Images used for illustrative purposes only. 1. Maximum ball download 150kg. Towbar (1,500kg braked & 750kg unbraked – petrol and CRDI automatic) or (2,000kg braked & 750kg unbraked – CRDI manual). Towbar capacity subject to regulatory requirements, towbar design, vehicle design and towing equipment limitations. 2. Load capacity = 125kg evenly distributed across 3 bars with secure lock function. 3. Park assist is designed as driver assist function only and should not be used as a substitute for skilled driving and safe parking practices. While the park assist sensors monitor objects on approach, there may be occasions where blind spots affect the sensitivity of the sensors and as a result the area into which the vehicle is heading must be visually monitored by the driver at all times while parking.

*All Hyundai Genuine Accessories are subject to warranty conditions. See your nearest Hyundai Dealer or visit our website at www.hyundai.com.au for full warranty terms and usage recommendations. Accessories pictured are all sold separately at an additional cost.



Genuine Accessories



The iLoad Series II featured above is accessorised with a Full Technician Kit³, Commercial Roof Racks (3 bar set)³, Headlight Protectors (set of 2), Tinted Stylevisors (set of 2), Towbar, Towball & Trailer Wiring Harness¹, Technician Step, Sliding Door Windows and Alloy Nudge Bar. All sold separately at additional cost. Images used for illustrative purposes only.

iLoad Series II Colours & Finish

Exterior Colour

Creamy White
(YAC) – Solid

Timeless Black
(RB5) – Mica

Hyper Metallic
(P2S) – Metallic

Interior Colour

Woven cloth interior
Grey Two-tone (KD)

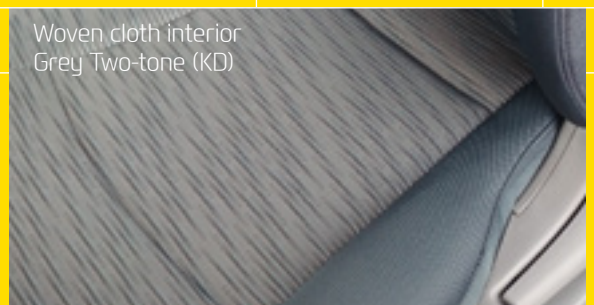

Colours are indicative only and may vary due to the printing process. Metallic and Mica paint are optional extras.

iLoad Series II Features



Rear view camera



Dual front and side airbags



Tilt steering column
Steering wheel audio controls



Cruise control



Folding remote key



6 seat crew van



Power windows and mirrors



7" touchscreen audio system



Dual glovebox with cooling in the upper compartment



Twin front door pockets



Air conditioning



12V power outlet



Rear wheel drive



Optional twin swing doors



Vinyl cargo area floor covering



Height adjustable driver's seat



Tie down hooks



Overseas model shown

Two sliding doors for easy access



iLoad Series II van

iLoad Series II Crew van

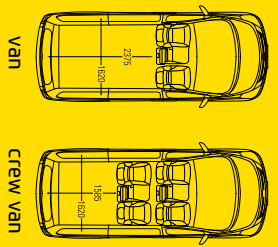

iMax Series II

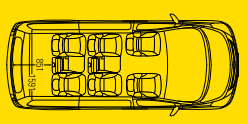

The Right Balance for your Business

If you're serious about:

- Selecting the right vehicle for your business
- Reducing your fleet's whole of life costs
- Reducing your fleet's environmental impact
- Providing a safer environment for your greatest assets, your employees

Make the right business decisions not the same decisions you've always made – consider the Hyundai Fleet Advantage!

The Smart Fleet Choice

Across the range, Hyundai saves you money. Exceptional fuel efficiency helps keep costs low, while our class-leading cost of ownership minimises off-road time and reduces service costs. For ultimate peace of mind, the iLoad is backed by an impressive Five Year 160,000 Kilometre Warranty*.

Hyundai Fleet Safety

Comprehensive passive and active technology is integrated into every model we manufacture. Utilising a global network of research and development centres of excellence, we design and deliver optimum occupant protection across our entire range of vehicles. This dedication of safety has resulted in Hyundai achieving high safety ratings, across our entire passenger car range.

Environmental Credentials

Hyundai is committed to working with you to achieve environmental sustainability through intelligent and informed fleet choices. Reducing your fleet size is not always an option, but making clever choices is. We can help you reduce your carbon footprint, and, by choosing from Hyundai's selection of vehicles offering low CO₂ outputs, you can reach your fleet emission reduction goals, meet Government targets and realise cost efficiencies for your business.

Whole-of-Life

Whole-of-Life is the calculation of the total projected cost of the operation and management of your fleet. Knowing and managing this data allows you to maintain budget expenditure projections, replacement provisions, and operational costs. You can depend on Hyundai's low Whole-of-Life costs to support your decision to choose us as your fleet partner, assist you to balance the fleet management equation and give you an advantage, the Hyundai Fleet Advantage.

***5 year/160,000km warranty:** For ultimate peace of mind, each Hyundai commercial use vehicle is backed by an impressive 5 year/160,000km warranty, whichever comes first.



NEW THINKING.
NEW POSSIBILITIES.

Hyundai Motor Company Australia Pty Ltd 394 Lane Cove Road, Macquarie Park, NSW Australia 2113 Hyundai Motor Company (HMC) and the Hyundai Motor Company Australia (HMCA) each reserve the right to alter vehicle specifications and equipment levels without notice. Some equipment featured on the cars in this brochure may not be available in Australia or may be optional. To the extent permitted by the law, neither HMC nor HMCA shall be liable to any person as a result of reliance on the content of this brochure. Please consult your Hyundai dealer for the latest specifications, equipment levels, options, prices, colours and vehicle availability. Metallic and mica paint are optional extras. Note: Information in this brochure is current as at 19/06/2016. HMCA10206 **Part No. T006168**