

# HOLDEN UTES VANS & ONE-TONNERS

Trust 'em to get your job done.



Kingswood interior illustrated above. • One-tonner body illustrated is not standard equipment.

A pleasure  
to do business  
with ...  
**HOLDEN**

# UTES

Take down-to-earth engineering integrity and wide track, load carrying ability. Put them together with the comforts of a Sedan — and you've got Holden Utes.

**More chassis durability ...**

That engineering integrity starts with the chassis. It's tempered steel in a full length box section. Now even more durable for longer life. Tough ... Holden tough. Built, tested and proven in rugged Australian conditions.

**Your engine choice.**

Your power comes from the reliable, economical Holden 3.3 litre six cylinder engine. And, if you do need even more working muscle, you can option up to the 4.2 litre or the 5.0 litre V8.

Power assisted front disc brakes stop when you say stop.

And the handbrake is floor mounted out of your way.

**More armchair comfort ...**

Choose from two models. Kingswood Ute and Holden Ute. Kingswood offers you a little more in the way of features. Both offer sedan comfort inside with full foam bench seat — fitted now with a pull

down arm rest for an easy-chair position.

You've more of the comforts of home in the cab with flow-through ventilation (fan boosted on Kingswood). Attractive, tough "Sadlon" upholstery wipes clean in seconds.

Feel at home in Holden's Utes at work all day. Then put on your glad rags for a night on the town — driving Holden Ute all the way!

**All this — and Radial Tuned Suspension for confident road holding!**



All illustrations and specifications contained in this catalogue are based on the latest product information available at time of publication approval. The right is reserved to make changes at any time, without notice, in prices, colours, materials, equipment, specifications and models, and to discontinue models. Some of the equipment shown throughout this catalogue is optional at extra cost. Check with your Holden Dealer for complete information.



Another way to  
unload your light  
transport problems.  
**HOLDEN**

# VANS

It's not difficult to see why these roomy Holden Vans rate No. 1 in light commercial van sales. A few minutes test driving one of these beauties and you know you've found a working partner you can trust. Look at the way that tailgate opens wide, half up and half down, perfect for carrying that overlength load — like pipes, beams, ladders. Look at the 2.9 cu. metres (105 cu. feet) of fully usable space. Two models, Kingswood and Holden. You get a little more in the way of features with Kingswood.

And look at the way this van is built. Underneath, a full length box section tempered steel chassis... Now more durable for longer life. Toughest thing you'll see outside of trucks. A solid steel floor and double steel lower sidewalls. Holden Vans can take everything you hand them — and then some!

Your engine? Standard is Holden's well proven and economical 3.3 litre six-cylinder. But if you're looking for a bit more thrust, you can choose either the

4.2 litre or 5.0 litre V8 at moderate extra cost. On all these, the service intervals are only once every 10,000 kilometres or six months. Holden vans have sure stopping power too. Power assisted front discs and rear drums give you complete command at all times. And when you want to stay stopped — you'll find Holden's tuck-away handbrake very conveniently located on the floor at your side.

### Relax — it's almost an armchair.

And your personal comforts? Both Holden Panel Vans now offer you the relaxation of a sedan style pull-down centre arm-rest in the big comfortable front bench seat.

You stay more comfortable on hot days with Holden's flow-through ventilation system. In the Kingswood, this feature is fan-boosted to give you fresh, outside air even when stationary.



If you're looking  
for a friendly  
workhorse...

# HOLDEN ONE TONNER

Holden's versatile workhorse — the One Tonner light commercial for all Australia, and all kinds of carrying jobs. You'll find these great hearted vehicles in a hundred and one applications, on the land, in the city and in between!

**All the strength you need...**

You start with Holden's tough, full length box section steel chassis, now even more durable for longer life. And Holden's reliable 3.3 litre six-cylinder engine. Looking for more performance? Option up to the 4.2 litre V8. Your stopping power is no slouch, either. Power-assisted front disc brakes and rear drums are just waiting for your

orders! 3-speed manual column shift is standard, or you may choose optional four-on-the-floor manual — or Holden's smooth Tri-matic automatic.

Look at the sedan comfort of that cab. You can stretch your legs out as far as you like — and you know how important that is during the working day. So's Holden's flow-through ventilation system, delivering a cabful of fresh, outside air every few seconds.

You sit, literally, on a cushion of foam in the One Tonner's wide bench seat. And how welcome is that broad, padded pull-down centre armrest. Holds you firmly in

place — or pushes up into the seat back for 3-man accommodation.

Now, all you have to do to tailor Holden One Tonner for your particular business is choose the body that's right for your job. A specialised application? Just take a look at the illustrations on these pages. These can be developed by your local body builder. Just have a chat with your Holden Dealer ... there isn't anything in one tonne transport Holden can't take on.

**All this — and Radial Tuned Suspension to give more confident road handling.**



Optional appearance feature package illustrated.

Optional appearance feature package illustrated. Body applications illustrated above are not standard equipment.

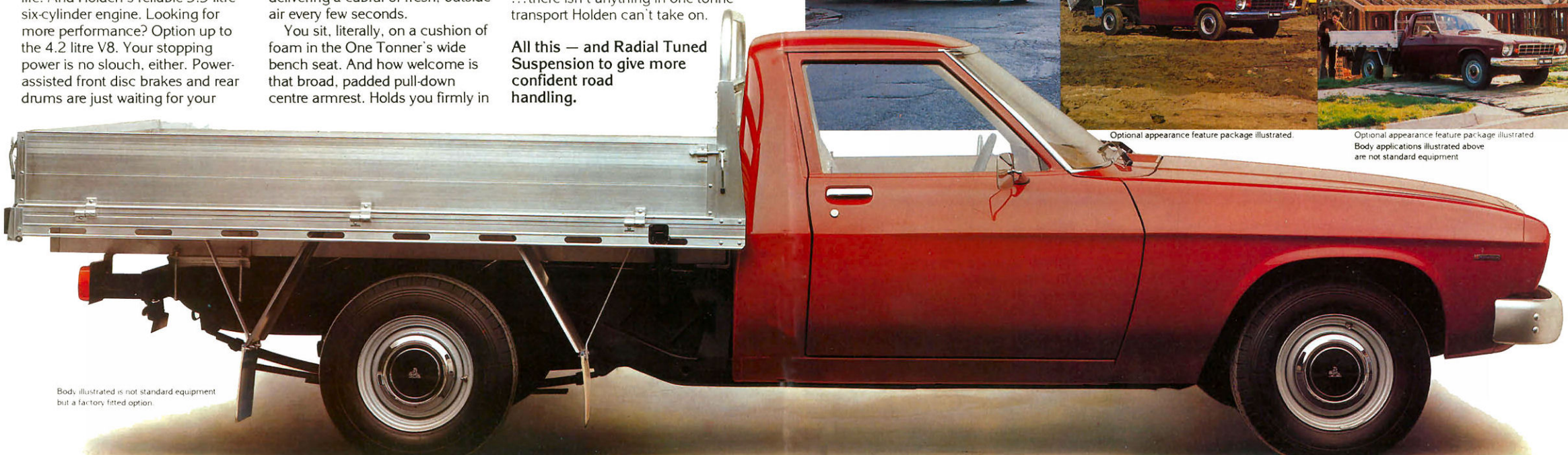

Body illustrated is not standard equipment but a factory fitted option.



Kingswood interior illustrated above.



**Holden Interior comfort.** Whether you choose Ute, Van or One Tonner, you'll find the cab full of sedan comforts. That deep, wide bench, is cushioned with a special resilient foam which moulds to your body shape. It becomes a real armchair when you pull down the broad, padded centre armrest. Being a Holden, your commercial is built Australian-size. Plenty of leg room. Heaps of headroom. Flow-through ventilation assures your cool — it's fan-boosted in Kingswood Ute and Van to bring in fresh, outside air even standing still. (Fan boosted ventilation optional on One Tonner, Holden Van and Ute).

# HOLDEN RADIAL TUNED SUSPENSION



We are proud that Holden automotive engineering has reached a

Radial Tuned Suspension is a hallmark in the development of automotive safety and road performance.

Radial Tuned Suspension matches all suspension components to radial tyres.

But at Holden's we take greatest pride in the new dimension of safety this system offers. Safe and predictable handling. The ability to avoid an accident. And that ability is the result of Radial Tuned Suspension.

point where we can offer all this. Holden's Utes, Vans and One Tonner have the same predictable handling fully laden to design load. (If you've ever had to make an emergency manoeuvre with a fully laden vehicle, you'll appreciate what an important benefit this is.)

The rougher the road, the more you'll notice the improvement. You're ready to take on any road in Australia.



Evasive capability is superb. In situations where a collision was previously inevitable, the driver can call upon exceptionally quick steering response, tremendous tyre adhesion to the road, predictable cornering with a minimum of body lean, reduced chance of skidding or spinning into an accident.

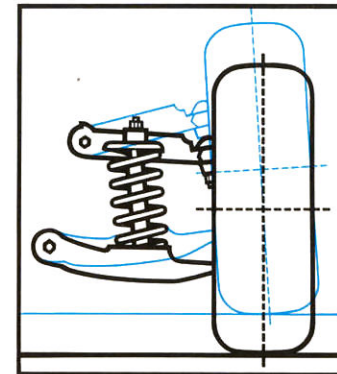

Suspension is computer-designed to keep optimum tyre tread on the road while cornering.

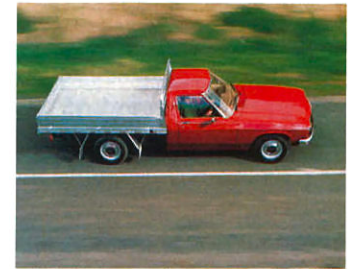

Optional appearance feature package illustrated. Body illustrated not standard equipment

And when the weather turns bad, RTS really shines. The radial tyres give tremendous wet-weather traction. And the rest of the RTS system keeps them glued to the road, to get the best out of them. If the wind comes up or a truck passes you, RTS keeps you going straight ahead with no drama.

Trust your Holden light commercial with Radial Tuned Suspension. It belongs to the finest handling family of vehicles we've ever built.

- \* RTS means more safety — more control in emergencies.
- \* RTS means better handling and steering response.
- \* RTS means a better ride, whatever the road condition.
- \* RTS means better driving economy, improved fuel economy and tyre mileage.

**RTS — Another First on Holden Light Commercials.**

# OPTIONS PERSONALISE YOUR UTE, VAN OR ONE-TONNER

For even more comfort, convenience and performance consider these Holden options:

- Full foam bucket seats and carpet (No extra cost on Kingswood).
- Air conditioning.
- Push button AM radio.
- Full instrumentation — including tacho, clock, oil, water and ammeter gauges.
- Windshield wipers dwell control.
- Tinted or clear laminated windshield.
- 4-speed manual transmission.
- Automatic transmission.
- Limited slip differential.



1

- 60 amp/hr deep cycling heavy duty battery.
- Heavy duty radiator.
- Outback equipment pack.
- Quartz halogen semi sealed headlamps (Utes & Vans).
- One Tonner available with factory fitted aluminium drop-side tray body. An appearance feature package is another One Tonner option.

Ask your Holden Dealer for details of other options available.

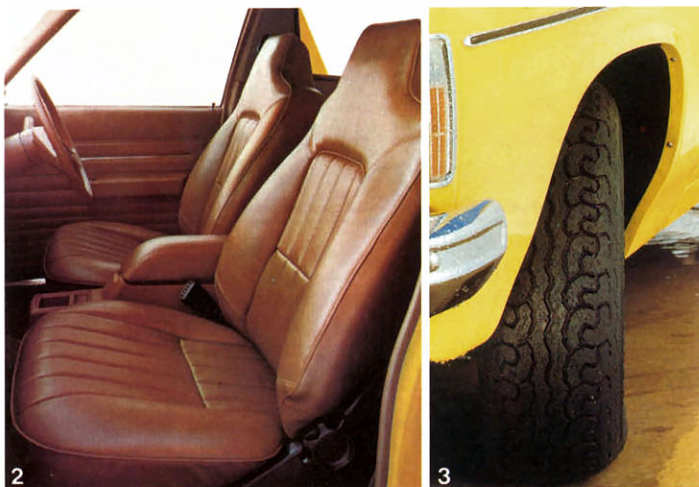

2

3



4

## Safety at work.

GMH has pioneered many safety features on Australian vehicles. Holden Light Commercials incorporate all the following: Fusible link wiring. Energy absorbing steering column. Tandem master brake cylinder and split circuit hydraulic brake system. Glare reduced instruments and mirrors. Skid header panel. Safety glass all round. Modified zone windscreen. And now the confidence of Radial Tuned Suspension. And much more...

## Options illustrated:

1. 4-speed manual transmission and floor-shift console.
2. Reclining bucket seats and high-rise centre armrest.
3. A wide range of steel belted radial ply tyres — Utes and Vans.
4. Full sports instrumentation, push-button radio, the works!



## HOLDEN ENGINES

Standard is the engine that has become a legend for reliability in every tough Australian condition — the Holden 3.3 litre six cylinder. Clean running and economical, this engine is so well engineered that regular service intervals are now recommended every 10,000 kilometres or six months.

## TRANSMISSIONS

### POWER TRAIN CHART

Engine	Standard Transmission	Optional Transmissions
Standard 3.3 litre six-cylinder.	3-speed manual — column shift.	4-speed manual floor shift. 4-speed wide ratio manual — floor shift. 3-speed Tri-matic automatic — column or floor shift.
Optional 4.2 litre V8.	3-speed manual — column shift.	4-speed manual — floor shift. 3-speed Tri-matic automatic — column or floor shift.
Optional 5.0 litre V8 (not available One-Tonner).	—	4-speed close ratio manual — floor shift. 3-speed Turbo-Hydrumatic automatic — floor shift.

## UTE SPECIFICATIONS



### (STANDARD MODEL)

**Engine:** 3.3 litre 6-cylinder. Bore and stroke: 92.0 x 82.5 mm (3.625 x 3.250 ins.). **Capacity:** 3298 cm<sup>3</sup> (201.25 cu. ins.). **Compression ratio:** 9.4:1. **RAC rating:** 31.5. **Transmission:** 3-speed manual, all synchromesh, column mounted. **Ratios:** 1st 3.07:1. 2nd 1.68:1. 3rd 1.00:1. Rev. 3.59:1. **Rear Axle:** Type: Banjo. Ratio 3.55. **Radial Tuned Suspension:** Front: Independent — with coil springs. Rear: Semi elliptic leaf springs. **Brakes:** Front: Power-assisted discs. Rear: Drums; duo servo. **Fuel Tank Capacity:** 70.4 litres (15.5 gals.). **Wheels:** 6.00 x 14 J.J. safety flange rims. **Tyres:** 195SR14 textile belted radials. **Turning circle:** Kerb to kerb 12.3 m (40.5').

Maximum GVM	Normal Payload Rating	500 kg.* Payload Rating
6-cylinder	2155 kg. (4751 lbs.)	1800 kg. (3968 lbs.)
Optional V8	2200 kg. (4850 lbs.)	1900 kg. (4189 lbs.)

### ESTIMATED KERB WEIGHTS

	Normal Payload Rating	500 kg.* Payload Rating
6-cylinder Holden	1366 kg. (3012 lbs.)	1358 kg. (2994 lbs.)
6-cylinder Kingswood	1376 kg. (3034 lbs.)	1368 kg. (3016 lbs.)
Optional V8 Holden	1438 kg. (3170 lbs.)	1430 kg. (3153 lbs.)
Optional V8 Kingswood	1448 kg. (3192 lbs.)	1440 kg. (3175 lbs.)

\* Check with your Holden Dealer on tyre specifications required to achieve this payload rating.

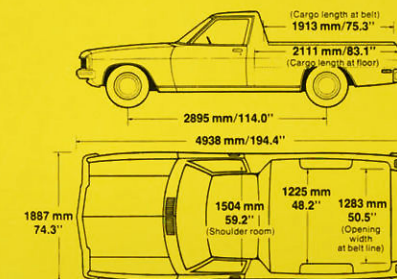

# VAN SPECIFICATIONS



## (STANDARD MODEL)

**Engine:** 3.3 litre 6-cylinder. **Bore and stroke:** 92.0 x 82.5 mm (3.625 x 3.250 ins). **Capacity:** 3298 cm<sup>3</sup> (201.25 cu. ins.). **Compression ratio:** 9.4:1. **RAC rating** 31.5.  
**Transmission:** 3-speed manual, all synchromesh, column mounted. **Ratios:** 1st 3.07:1. 2nd 1.68:1. 3rd 1.00:1. Rev. 3.59:1. **Rear Axle:** Type: Banjo. Ratio 3.55:1. **Radial Tuned Suspension.** Front: Independent with coil springs. Rear: Semi elliptic leaf springs. **Brakes:** Front: power-assisted discs. Rear: drums; duo servo. **Fuel tank capacity:** 70.4 litres (15.5 gals.). **Wheels:** 6.00 x 14 JJ safety flange rims. **Tyres:** 195SR14 textile belted radials. **Wheelbase:** 2895 mm (114.0"). **Turning circle:** Kerb to kerb — 12.3 m (40.5').

Maximum GVM	Normal Payload Rating	500 kg.* Payload Rating
6-cylinder	2155 kg. (4751 lbs.)	1900 kg. (4189 lbs.)
Optional V8	2200 kg. (4850 lbs.)	1950 kg. (4299 lbs.)

## ESTIMATED KERB WEIGHTS

	Normal Payload Rating	500 kg.* Payload Rating
6-cylinder Holden	1429 kg. (3150 lbs.)	1421 kg. (3133 lbs.)
6-cylinder Kingswood	1440 kg. (3175 lbs.)	1432 kg. (3157 lbs.)
Optional V8 Holden	1501 kg. (3309 lbs.)	1493 kg. (3291 lbs.)
Optional V8 Kingswood	1512 kg. (3333 lbs.)	1504 kg. (3316 lbs.)

\* Check with your Holden Dealer on tyre specifications required to achieve this payload rating.

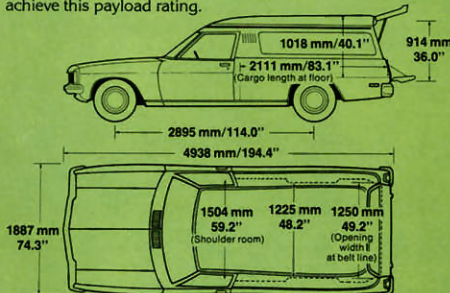

## GMH 12/20 Warranty.

Every Holden Light Commercial vehicle is covered by the GMH Warranty which covers your vehicle for the first 12 months or 20,000 kilometres, whichever occurs first. You're also backed by the biggest Dealer network in Australia — more than 500 Holden Dealers to provide service and spares wherever your business or pleasure takes you.

# ONE-TONNER SPECIFICATIONS



Body illustrated is not standard equipment. Optional appearance feature package illustrated.

## (STANDARD MODEL)

**Engine:** 3.3 litre 6-cylinder. **Bore and stroke:** 92.0 x 82.5 mm (3.625 x 3.250 in). **Capacity:** 3298 cm<sup>3</sup> (201.25 cu. ins.). **Compression ratio:** 9.4:1. **RAC rating** 31.5.  
**Transmission:** 3-speed manual. All synchromesh, column mounted. **Ratios:** 1st 3.07:1. 2nd 1.68:1. 3rd 1.00:1. Rev. 3.59:1. **Radial Tuned Suspension.** Front: Independent, with coil springs. Rear: Semi elliptic leaf springs — Two-stage/3 primary leaves/3 secondary leaves. **Rear Axle:** Type: Heavy duty Salisbury. Ratio 4.44:1. **Brakes:** Front: power-assisted discs. Rear: drums; duo servo. **Fuel tank capacity:** 70.4 litres (15.5 Imp. gals.). **Wheels:** 6.00 x 14 JJ safety flange heavy duty rims. **Tyres:** 195R14LT 8 ply rating steel belted radials. **Wheelbase:** 3058 mm (120.4"). **Turning circle:** Kerb to kerb: 12.8 m (42.0').

## Maximum GVM

6-cylinder	2600 kg.* (5732 lbs.)
Optional V8	2660 kg.* (5864 lbs.)

\* This is the maximum aggregate weight at which the Holden One-Tonner must be registered to operate.

## ESTIMATED KERB WEIGHTS

6-cylinder	1287 kg. (2837 lbs.)
Optional V8	1359 kg. (2996 lbs.)

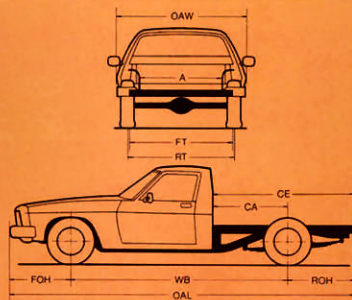

OAW Max. Overall Width 1874 mm (73.8"). FT Front Track 1511 mm (59.5"). RT Rear Track 1529 mm (60.2"). WB Wheel Base 3058 mm (120.4"). OAL Max. Overall Length 4854 (191.1"). FBH Front overhang 855 mm (33.7"). ROH Rear overhang 939 mm (37.0"). CA Back of cab to rear axle centre line 1062 mm (41.80"). CE Back of cab to end of frame 2001 mm (78.78"). A Width between 'theoretical' wheel arches 1224 mm (48.20").



General Motors-Holden's Sales Pty. Limited  
 Issued October, 1977. Copyright K247