

NEW HOLDEN COMMODORE V6. A WORLD OF DIFFERENCE.



1995



**HOW DO  
WE IMPROVE ON  
NUMBER ONE?**

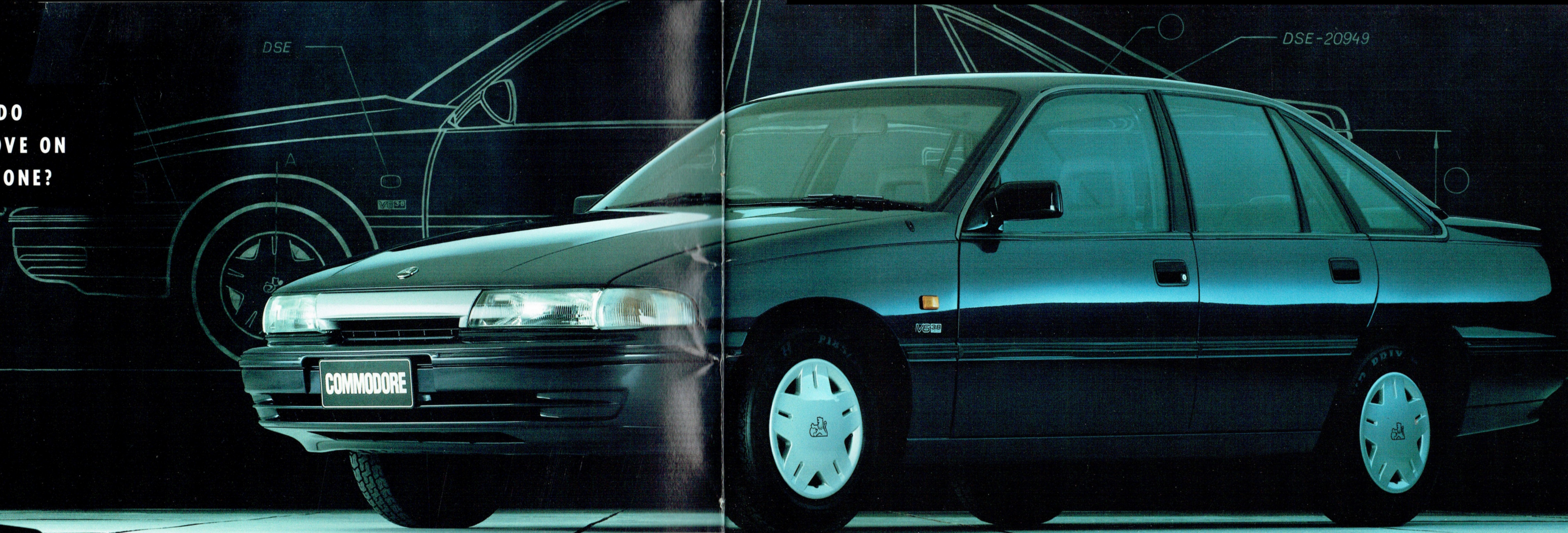

Holden Commodore is Australia's number one car. We realised there was only one way to top that. Make its successor not just Australia's best-ever Commodore, but one of the world's best production cars.

By drawing on the vast technological resources of General Motors worldwide. Then applying them to the unique conditions we have here in Australia.

So Holden is now the first six cylinder Australian family car to offer you the safety of independent rear suspension. Designed by GM in Germany and perfected in Australia.

Just as we were first to bring you the efficiency of a V6 engine. Born in America, bred in Australia. And now even smoother and quieter.

Our on board computers, engine management systems

and other electronics give you the best of American know-how. Commodore's build quality is consistently improving in the hands of our robots from Japan.

Our \$40 million computerised corrosion-proofing and paint protection plant is equal to any in the world. Every VP Commodore is protected and primed by a zinc phosphate and electrocoat prime paint system. Further protection is

provided in areas most subject to corrosion with the use of galvanised steel panels.

During the process the car bodies are immersed in ten separate baths and seven separate spray zones outside the bath areas. Finally every body is baked in an oven specifically designed to cure electrocoat paint. Europe inspired our new anti-theft measures and Germany our design refinements.

These and many other influences may make the new VP Holden Commodore sound like a world car, but it's still Australia's own. Which, as you'll know, makes Commodore as sturdy and reliable as ever.

The first-class car for our tough conditions. And as big as ever. Comfortably accommodating a family of five. Even eight in some cases. And as big a performer as ever, Holden

Commodore remains unchallenged as the driver's family car. Commodore still offers you the biggest range of sedans and wagons, with our own legendary V8 option.

And the best value for money. Now even better, with extra equipment. From power door locks to power mirrors. Standard, right through the range.

The new Holden Commodore. It's a world of difference.



**BE THE FIRST IN YOUR STREET WITH INDEPENDENT REAR SUSPENSION AND ANTI-LOCK BRAKING.**

If we have some of the world's worst roads, why don't we have the suspension and brakes that best handle them? Now we do. With the optional Independent Rear Suspension on the new VP Commodore sedans. Designed in Germany and developed here, it's an Australian first in a big family sedan.

The rear wheels respond to the road surface independently of each other, keeping them in constant contact with

the road. If one wheel hits a bump, only one wheel feels it. And you barely feel it at all. This means mid-corner ruts won't suddenly and unnervingly send you off-line. It also means a far smoother ride. Giving you more confidence at the wheel, and your family more comfort on the road.

And as an additional safety feature on our V8 sedans with IRS, there's an optional Anti-lock Braking System (ABS)

that lets you stop very quickly, and steer while you're doing it - even on slick, wet highways.

The next best thing to our Independent Rear Suspension is our re-developed five-link suspension. Handling is tighter than before and road noise hushed. And, helped by suspension changes up front, the ride is now even smoother.

If you take big loads and rough roads, you can take

**ABS ANTILOCK BRAKING SYSTEM**

**BOSCH SERIES 2 SYSTEM**

- Wheel-Speed Sensor 1
- Wheel-Brake Cylinder 2
- Hydraulic Modulator 3
- Brake Master Cylinder 4
- Electronic Control Unit 5

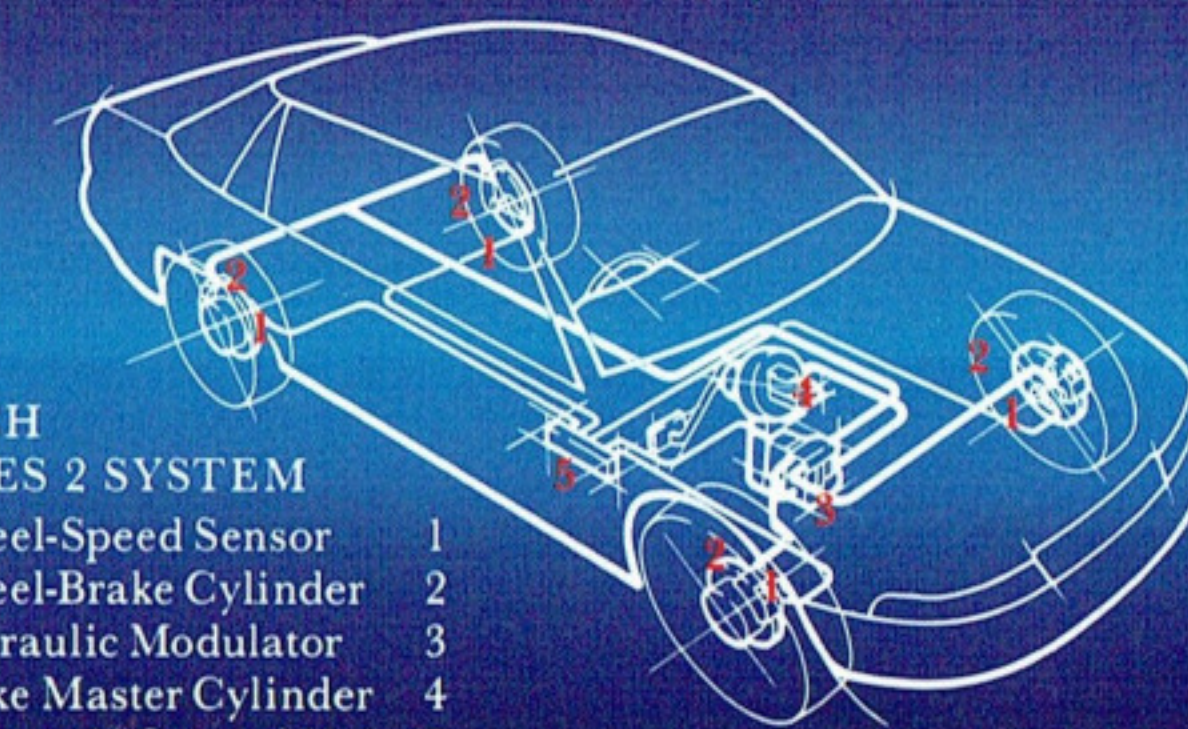

Commodore's Country Pack (an option on certain models). This gives you heavier-duty suspension, higher ground clearance and extra underside protection, for safety in the rough.

As Holden Commodore is Australia's driver's car, we've looked at everything a driver looks for. The steering now has more directional stability, keeping the car straight even over bumps. The brakes with their new, environmentally friendly, non-asbestos pads perform better, even when cold.

And the headlights' powerful high-beams benefit from new technology which cuts glare but not illumination.



**WORLD CLASS  
SECURITY IS TIGHT INSIDE  
EVERY NEW COMMODORE.  
SPACE ISN'T.**

If you look inside the new VP Holden Commodore you'll immediately be impressed by how big it is. Comfort to spare for five adults.

But a thief would be lucky to even get a look in. Because Commodore now bristles with new security measures, standard on every model.

All doors have the convenience of remote controlled



central power locking and door deadlocks as standard, with a convenient Mongoose electronic security system worked by a remote radio key, disabling the engine.

And the Commodore's sound system is PIN-coded making it inoperative to everyone but you.

Now while all of this is enough to deter any thief,

perhaps it's enough to attract your insurance company. They may now offer you generous concessions on your premium.

But that's not all. In fact, some think VP Commodore actually stands for value-packed.

Its new interior features include electric mirrors, an upgraded sound system and a smaller 'driver-sized' steering wheel (more on all this over the page). All adding to Commodore's

great value for money.

However, we have subtracted something. A further two decibels of noise inside.

Improved insulation and engine refinements combine to calm both engine and road noise to a hush. Providing a more peaceful environment in this rowdy world of ours.

Allowing you to enjoy some thinking time, your passengers



*Commodore Berlina interior.*

company or simply your favourite piece of music.

And the choice of our new German designed independent rear suspension, which absorbs noisy bumps, will no doubt further enhance its new found quietness.

All in all, you'll find that in the new Holden Commodore, there's room for everything, but improvement.



**EXECUTIVE, THE  
WORLD'S BEST-VALUE  
COMMODORE.**

DS-E-20959

A



© SHT 17

As you can see, the new Holden Commodore appears wider, lower and even more purposeful than before.

These subtle refinements have enhanced Commodore's clean sleek styling, inspired and wind-tunnel tested by General Motors-Opel in Germany.

But Commodore shows its international credentials in many ways. Our fuel-efficient V6 engine was originally

designed by General Motors in America.

Local refinements to this unit mean the new manual V6 Commodore returns a surprising 7.4l/100km Australian Standard 2877 test highway cycle (38 miles per gallon). While our optional independent rear suspension originates from GM Europe.

So Holden Commodore gives you the world. Both in

its technology and its value for money.

Commodore Executive sedan and wagon, where our range begins, are certainly no exception.

As well as being safer, quieter and more comfortable than ever before, the new executive now boasts a considerable array of added features.

The security of our new anti-theft measures. Power door

locks. Door deadlocks. A PIN-coded sound system. And a Mongoose electronic security system with a remote-control key disables the engine to anyone but you.

The convenience of electric exterior mirrors and central locking. An upgraded sound system, with improved radio reception in country areas.

A smaller, 'driver-sized' steering wheel for more precise

handling. Accommodating storage bins in the driver's and front passenger's doors.

There's even a time-delay on the interior light, so you're not in the dark the moment you shut the door. No more struggling to find the ignition.

The interior is finished off with a new, richer trim, producing a more comfortable driving environment.

Exterior improvements include stylish new wheel covers, new colours along with design changes both front and rear.

And, though you may not need to use it for some time, except to admire the engine, there's a hydraulic strut on the bonnet to keep it up.

New Commodore Executive. It took the world to make it so good, and Australia to make it such good value.



**BERLINA, THE  
WORLD'S MOST LUXURIOUS  
COMMODORE.**



Commodore Berlina has always gone to great lengths to put luxury into your family motoring such as standard cruise control. Now, with the new VP Berlina sedan and wagon, it goes even further especially with its 15-inch wheels as standard and European inspired roof rack (wagon only). Around the world in fact.

Our V6 engine and four-speed automatic transmission,

both originally designed by General Motors in America, are now even silkier. As befits the car.

Inspired by General Motors-Vauxhall of Britain, Berlina naturally includes our new package of Australian-designed anti-theft measures. Along with all the new interior features found in Commodore Executive. And more, a great deal more.

Inside you'll find a tachometer is now standard. As are

power-operated body colour exterior mirrors, front windows and remote door locks, with security deadlocks.

The front passenger, as well as the driver, now benefits from adjustable lumbar support. And from improved rear speakers which project the sound forward more effectively. Sound that is clearer than ever, thanks to improved FM reception on the stereo radio cassette system.

Berlina's interior trim is now even richer, with textured designer fabric on the seats, doors and head restraints. As before, the standard air-conditioning, with its twin rear ducts, comforts all your passengers.

So, there's plenty of practical luxury on the inside, where you appreciate it most. But there are also a number of exterior refinements. Body styling changes front and rear make the

most of Berlina's sleek lines. A look which is further enhanced by larger, 15-inch wheels with stylish new covers.

Elegant as they are, the new wheels aren't just cosmetic. Their larger size actually produces a smoother ride.

Of course, all these features are also available in the wagon. Making Berlina the perfect combination of luxury and practicality. But perhaps the new Commodore Berlina's

greatest luxury is that even with all these added refinements it's as affordable as ever.

Berlina now has a new Luxury Pack available as an option. The Luxury Pack includes automatic climate control (air-conditioning), trip computer, Calais instrumentation and body computer functions, power windows front and rear, anti-theft alarm system, alloy wheels, and much more.



OUR 'V' ENGINES,  
THE WAY THE WORLD  
IS GOING.

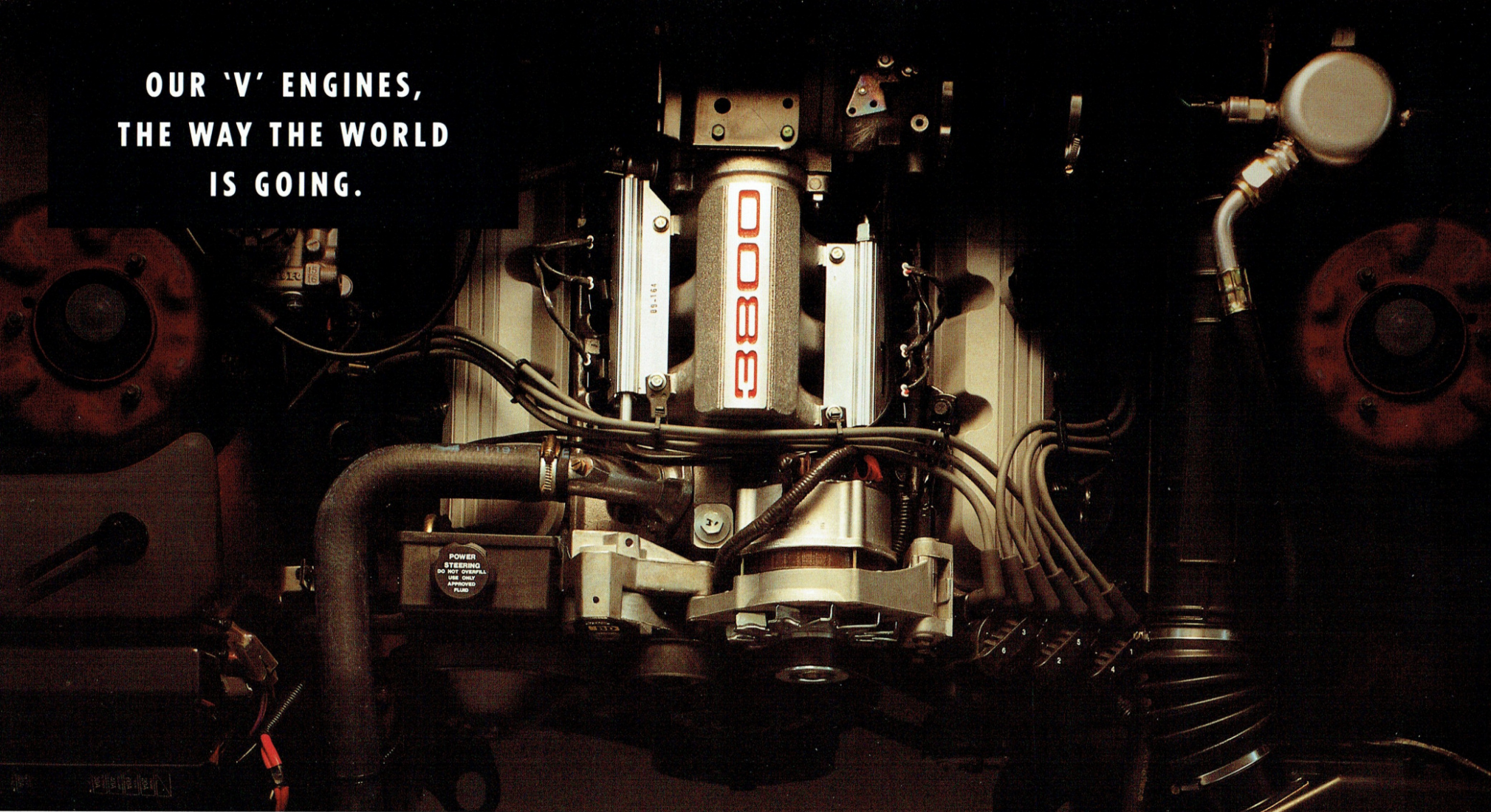

Alfa Romeo, Citroen, Honda, Maserati, Peugeot, Volvo, Rover. Today, the V6 engine propels the world.

General Motors has long been at the forefront of V6 technology, with not just Buick, Oldsmobile and Chevrolet, but Holden.

You see, the original Holden Commodore V6 was developed in the US by American engineers and perfected

here for Australian conditions.

Now this highly-efficient 3.8-litre engine has been further refined. It's smoother and quieter, and even more reliable. And though power is up to 127 kilowatts, it's not at the expense of your fuel economy.

The V6 manual sips just 7.4 litres over 100 kilometres, (on the highway cycle of the Australian Standard 2877 test). Or by

the old measurement, that's 38 miles per gallon.

This is assisted by Commodore's engine management computer, also developed in the US by GM. And by our multi-point electronic fuel-injection.

To say any more about our V6 engine might steal the thunder of our V8's. Mind you, there's plenty of thunder to steal.

In fact, there's a choice of two powerplants. A V8 with

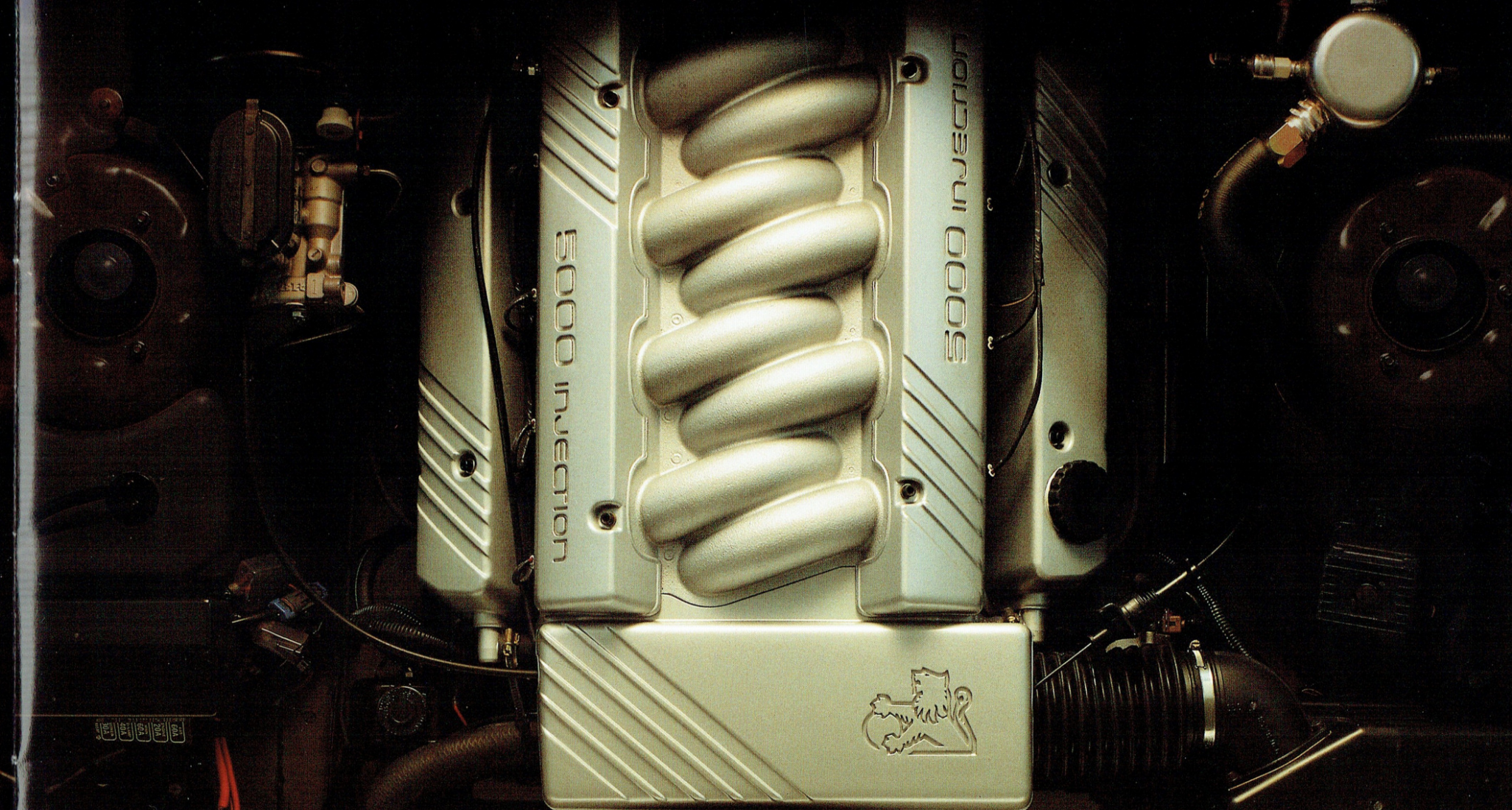

165 kilowatts of power and 385 Newton metres of torque for effortless towing or relaxed cruising. Or for those who need it, a V8 with 180 kilowatts and 400 Newton metres, available on any Commodore fitted with IRS and FE2 suspension.

This is delivered by a deep breathing air cleaner together with a new management computer calibration and a tuned extractor exhaust system, all developed by HSV.

Its high performance, however, has not sacrificed Holden's driveability or reliability. It's still tractable, untemperamental and very easy to drive at any speed.

Finally, our automatic transmission, again from GM America where it handles the power of Corvettes and Firebirds, has been made even smoother.

Commodore transmissions are just, as our research tells

us, how you want them. You get the precise control of a five-speed manual, standard on Commodore Executive, 'S' and 'SS'. And the convenience of four-speed automatic, standard on Berlina... with fuel-saving lock up torque converter.

Now before you turn the page, take another good look at our engines. The heart of any driver's car. And there are none more lion-hearted than Holden's.



**BIG AS A FOOTY  
GROUND, AND TAKES  
NEARLY HALF A TEAM.**



We've been building wagons as long as anyone. But this is our biggest yet. Something everyone will appreciate.

For a start, the new VP Commodore Executive wagon can seat as many as eight. With the kind of roomy comfort that won't let a happy family outing turn ugly.

Our special front bucket/bench has a wide armrest between two reclining bucket seats, which swings up for a

comfy third seat. An option at no extra cost with automatic transmission in both sedan and wagon.

Add our 'Plus 2' seat at the rear and you have room for eight. Rivalling, but outperforming, the 'people movers'.

'Plus 2' is a Commodore accessory, recommended for children up to eight years old. It's trimmed to match your wagon's other seats and has built-in seatbelts and head



restraints. And it's easy to fold away or remove. Best of all, 'Plus 2' faces forward. So your kids won't be dazzled by following headlights and they'll feel a lot safer.

But without the 'Plus 2' seat, what you'll find is one of the biggest usable cargo spaces in an Australian wagon.

Space that will swallow a chest of drawers. Or a stack of full-size house doors (with the tailgate shut).



The problem with some vehicles claiming a larger cargo volume, is they tend to look like a box. While our wagon has been designed as a model in its own right.

So if you're after a wagon so big you don't have to leave anything or anyone behind, Commodore gives you the choice of three models.



**COMMODORE  
TURNS UP THE HEAT  
A LITTLE.**



The very businesslike attitude of the Commodore 'S' instantly promises more. And it delivers.

Commodore's V6 engine and five-speed gearbox can get you to 100kmh in just 8.3 seconds and you'll look good doing it. Heavy-duty power discs all 'round haul you back again.

But in a real driver's car, handling is what counts. And our re-developed five-link suspension, or our new Independent



Rear Suspension make sure that, whichever you choose, it's fitted with our retuned FE2 sports suspension pack and 15-inch wheels with low-profile radials.

Inside, a tachometer and adjustable lumbar support help you take care of business while an upgraded four-speaker sound system takes care of pleasure.

For even more performance and safety, the 'SS' has the

**AND A LOT.**



formidable combination of V8 power and IRS as standard, together with optional ABS. 100kmh comes up in seven seconds flat. While hard bumps mid-corner won't suddenly send you off-line. Simply because the rear wheels respond to the road surface independently of each other, keeping them in constant contact with the road.

A wider front track further improves handling. The



wheels are new seven inch, turbine-style alloys. And a long-range fuel tank is standard. The only option you might seriously consider is our HSV-developed, 180 kW V8.

A new air dam with fog lights and a new wing spoiler with centre stop light are just a couple of the exterior features. While inside, there's everything you'd want in a driver's 'office'. After all, it's the car for those who drive themselves hard.



**LOCAL KNOWLEDGE  
MEETS  
GLOBAL KNOW-HOW.**



In November 1948, the first Holden 48-215, or FX, took to the road, since then it has been followed by, among others, the FJ, EH, Kingswood and, of course, Commodore. All of them Australia's own cars.

In those 43 years, we've got to know Australia pretty well. Its roads, its demands, and the needs of its families. After all, we've produced over five million vehicles for them.

Along with jobs, directly and indirectly, for around 80,000 Australians and recent exports of over two billion dollars.

Today however, it's no longer enough to export products. We must also import technology, to continue our tradition of bringing you cars of world standard.

So, capitalising on the vast technological expertise

of General Motors' world-wide, Australia's own Holden Commodore now benefits in many ways.

Styling, aerodynamics and our new independent rear suspension, from GM Germany.

Engines, engine management computer systems and automatic transmissions, from GM America.

Robotic assembly technology, from GM/Fanuc, Japan,

offers the very best build quality. Complementing our own anti-corrosion paint preparation plant, which was itself already world-class.

Such as European inspired anti-theft measures, adapted and made in Australia.

All this international technology, of course, is not just transplanted to Australia. It must be applied to our unique

conditions. (After all, suspension that's perfect for a smooth stretch of German autobahn, needs a little work before it's right for a rutted, outback road.)

Which usually involves adapting it, and improving it in the process. But in every case, exhaustively testing it. Both on our track at Lang Lang in Victoria and on the roads of Australia.

You see, just because it's good enough for the world doesn't necessarily mean it's good enough for us.

The cars above may be strikingly different, but in one respect nothing has changed.

Today's Commodore answers the challenges of Australian family driving in the nineties just as the FX did in the forties, in the best way possible.





**HOLDENWISE.  
SERVICE IS ONLY  
PART OF IT.**



Our cars obviously have changed in 43 years. Our commitment to Australia, however, has not.  
Nor has our commitment to protecting our customers and maintaining their cars. With HoldenWise service it has increased, in fact.  
Now, with the new Commodore, we've extended the service intervals so after the first 1500km service, 10,000km

will be your next visit – resulting in reduced service costs.  
HoldenWise have over five thousand specially-trained Holden dealer service and parts specialists spread around the nation; specialists who know first-hand about all the advanced technology on today's Holdens. And who are equipped with the latest service computers and machinery designed specifically for Holden motor vehicles.

With fixed-price servicing at participating dealers, you'll know exactly what you're up for, before they even pick up a spanner. And if something unforeseen crops up, they'll phone you before they do anything.  
There's a warranty of six months or 10,000 kilometres on all workmanship. If a fault arises, because of the service, it'll be fixed for nothing.

Plus all Holden quality parts come with a warranty of 12-months or 20,000 kilometres.  
A customer assistance line is also provided so you can call from anywhere, should you have any problems with the service.  
Finally, our service offers you an extended vehicle warranty customer protection plan.  
For a relatively small cost, you can increase the Holden

12/20 warranty by one, two or three years.  
This warranty covers parts and labour for mechanical and electrical repairs, even the cost of car hire if your car's out of action for more than two days.  
There's over 350 dealers in the HoldenWise national network so you don't have to drive miles for service. And being computer-linked through to the factory, you don't

have to wait days for parts to be found.  
HoldenWise. It may well add to the resale value of your Commodore in the years ahead. It will certainly add to your enjoyment in the miles ahead.





MAKE YOUR  
COMMODORE LIKE NO  
OTHER IN THE WORLD.

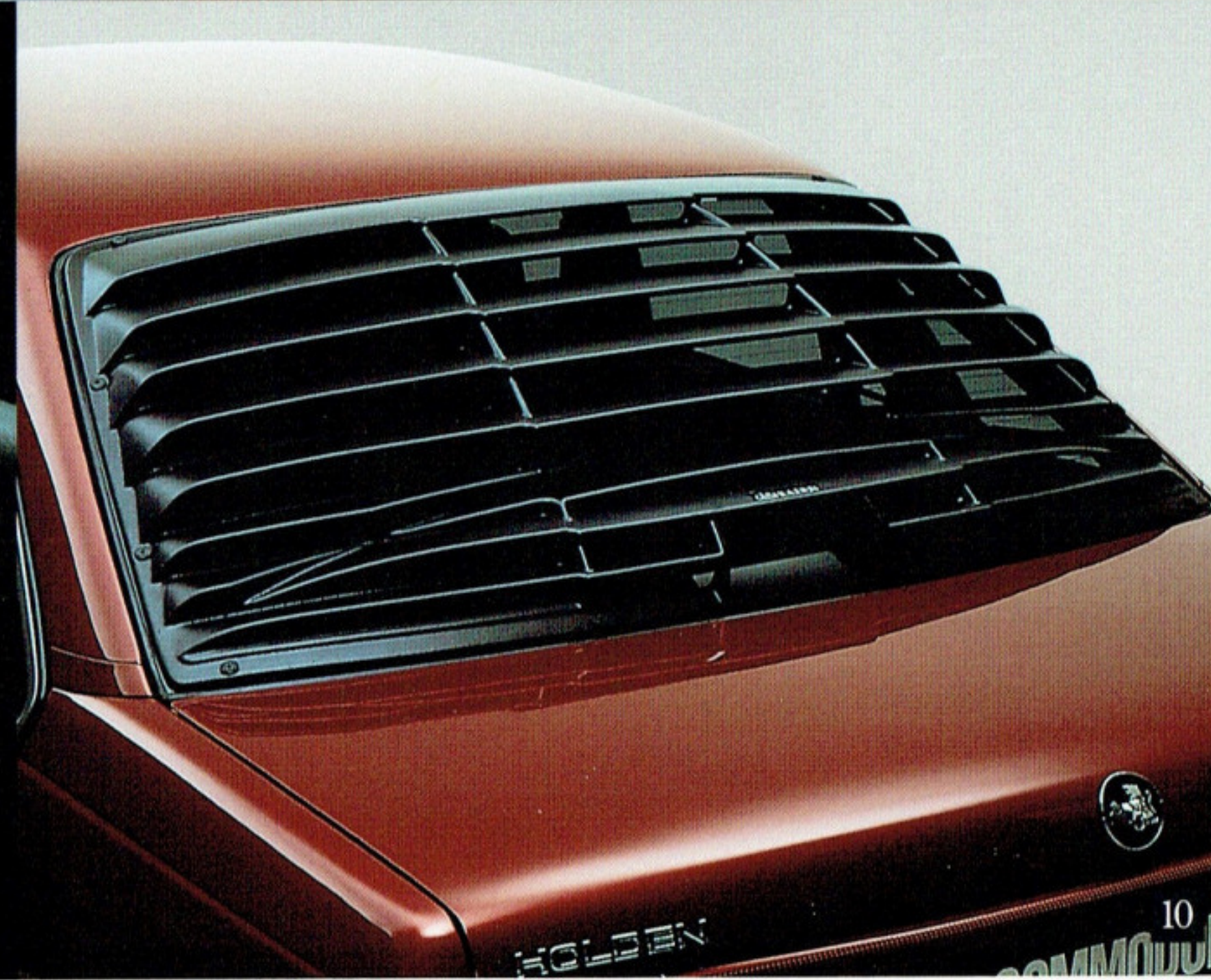
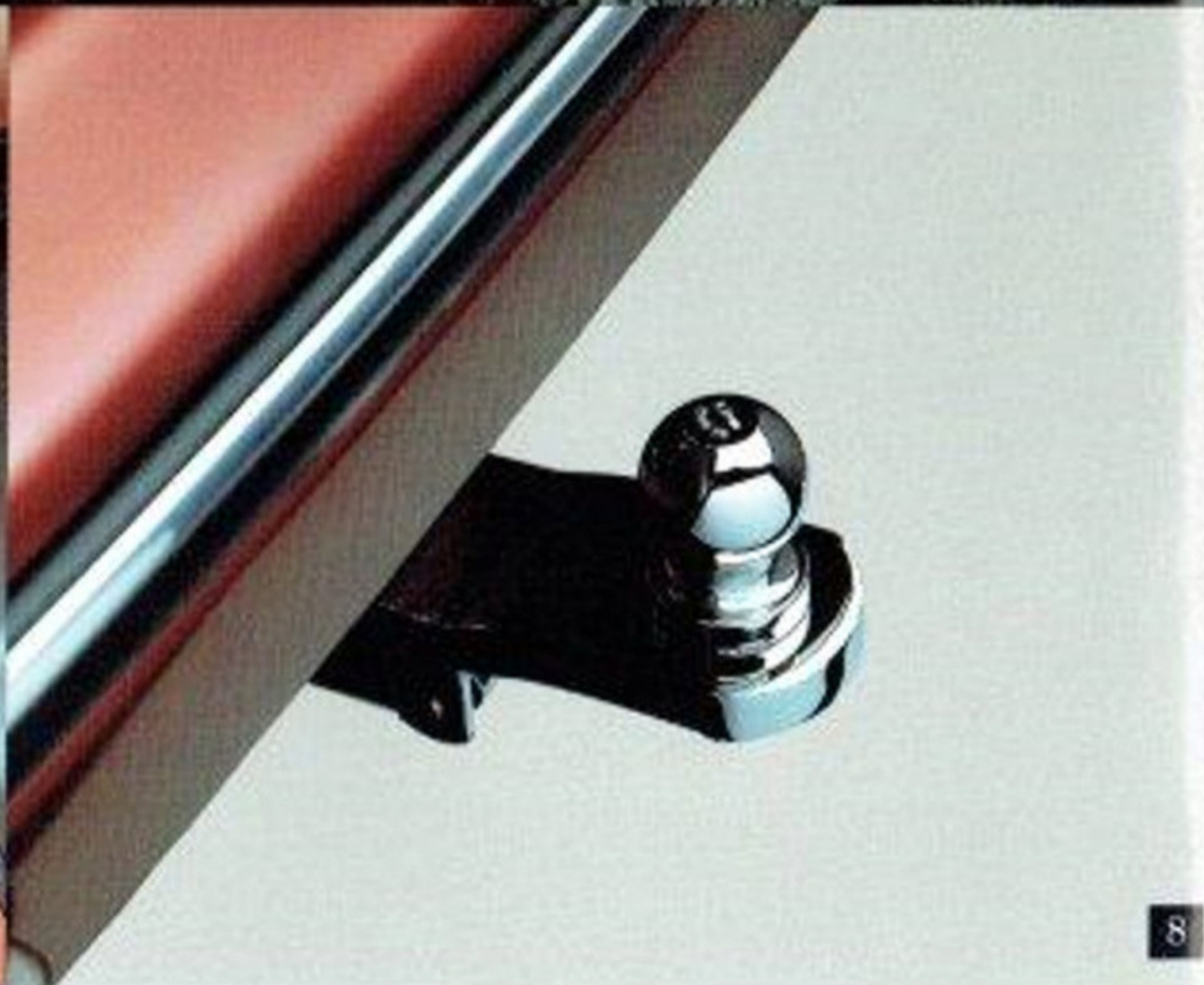
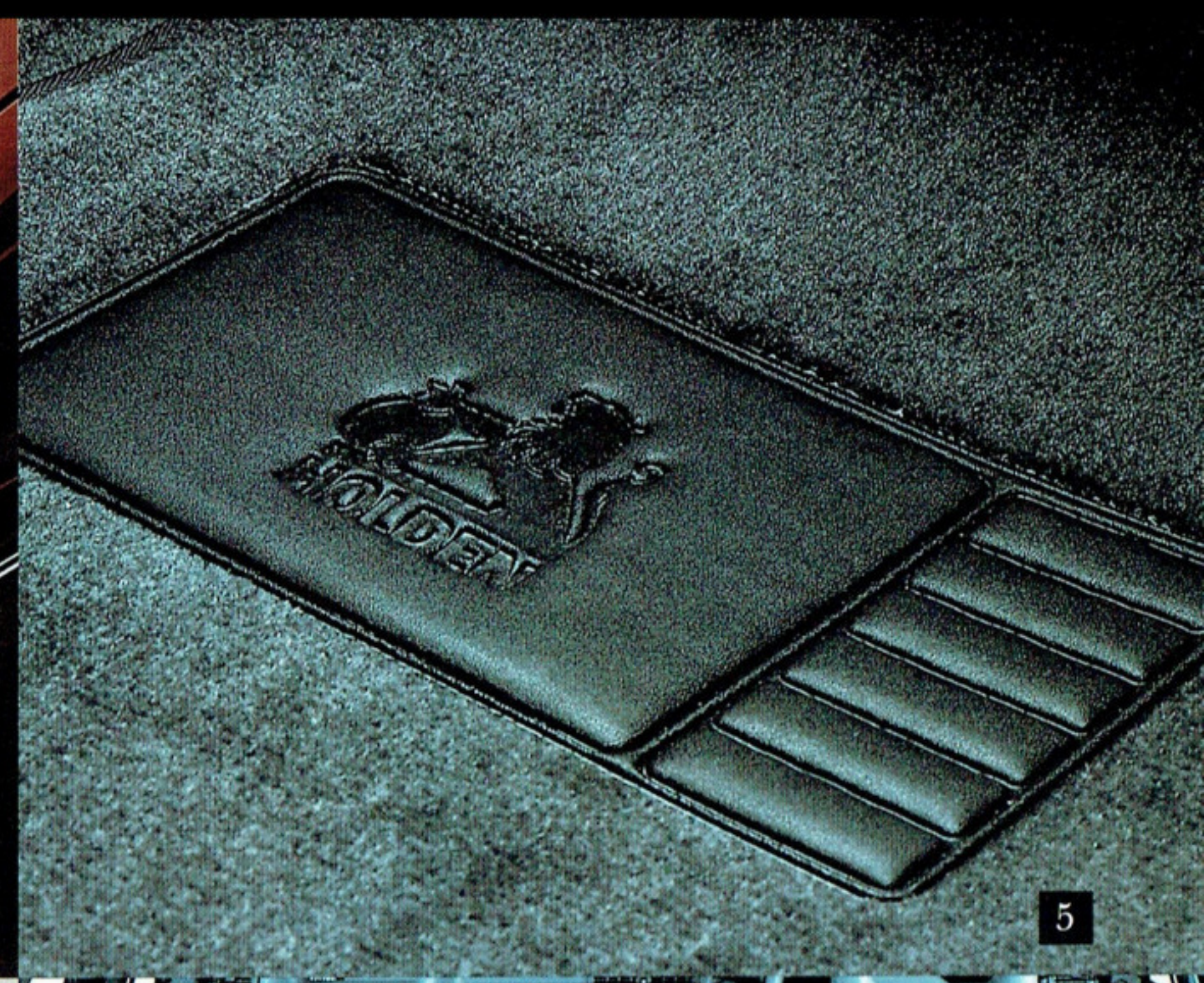
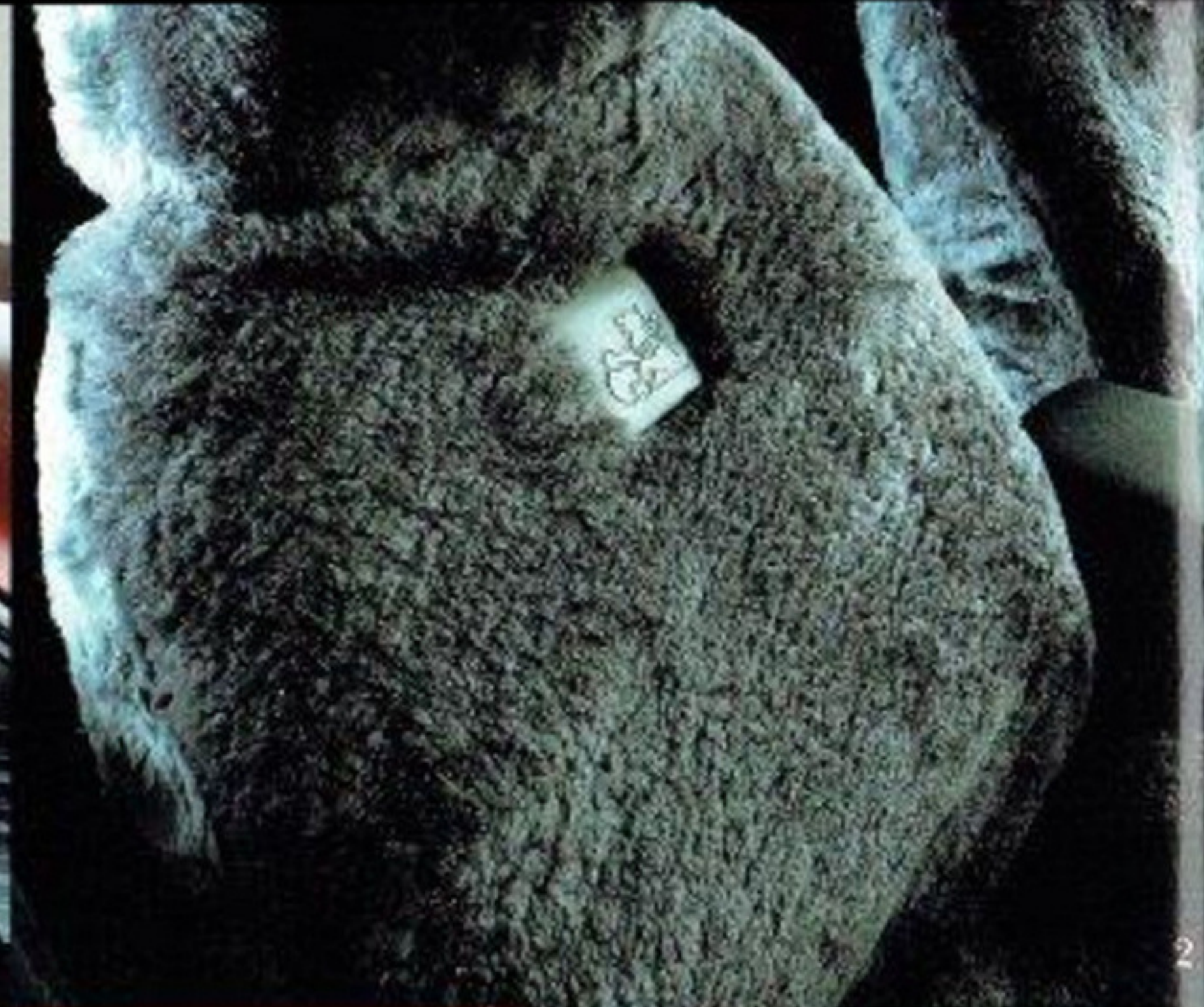

Like most cars, Holden Commodore is not a one-off that's built specially to your order.

But it can be. Easily. With the huge range of Holden-approved Commodore accessories.

You can make your Commodore even more stylish, more comfortable and more practical. And you can make it like no other on the road.

Which accessories you choose will obviously depend upon your needs and where you drive. There are dust deflectors, sun shades, weathershields and splash guards for those who travel long distances. Tow bars with different load capacities for people with caravans and trailers. And even a wagon cargo cover for those who carry valuable equipment.

If it's a matter of style, maybe the sedan enhancement of

the Holden Design Formula pack with rear spoiler, skirts, front air dam, formula grille and distinctive styling is more for you.

All Commodore accessories are designed to fit precisely, as an integral part of your car. (In fact, in some cases they are standard equipment on certain models. See inside back cover.)

It's much more convenient to have them fitted from the

start. Your Holden dealer will happily do this for you, as part of your total Commodore package.

And unlike many other non-genuine accessories, Commodore's are all covered by Holden's 12-month or 20,000-kilometre warranty. The accessories shown here are:

1. Roof rack for the sedan (different chrome unit for wagon).
2. Sheepskin seat covers to keep you warm in winter and cool

in summer. 3. Front and rear splash guards to protect your duco from gritty mud. 4. Headlamp guards and bonnet deflector to protect against stones. 5. Carpet mats. 6. Wagon venetian shades and tailgate dust deflector. 7. Driver and passenger side weathershields to deflect wind and rain. 8. Towing equipment - 1200kg for normal or 1590kg capacity for heavy duty use. 9. Holden approved mobile phone.

10. External rear louvre for sun protection. 11. Wagon cargo cover for added security.

Other popular accessories not shown here include air conditioning, front & rear mudflaps, sedan venetian shades, front sunshade, chrome exhaust extension and number plate frames.

Complete accessory details are listed inside back cover.



DSE-20848

# WHICH COMMODORE IS YOUR NUMBER ONE CAR?

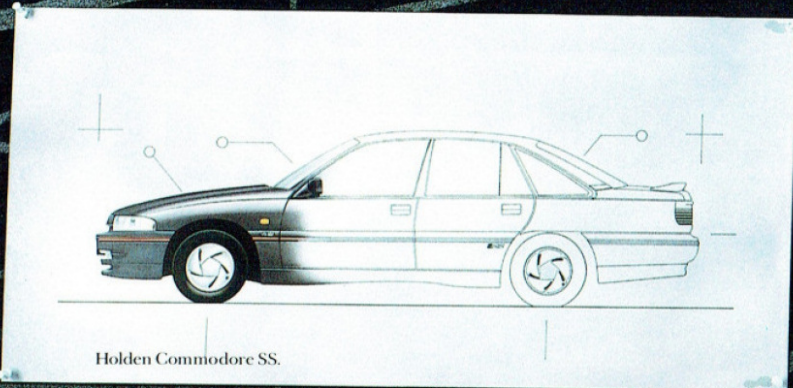

Holden Commodore SS.

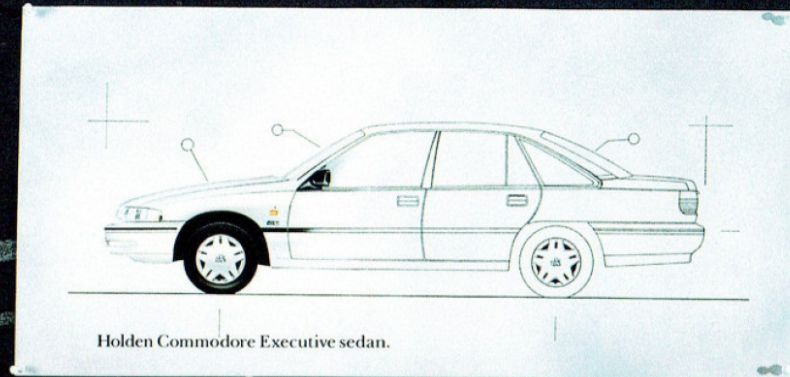

Holden Commodore Executive sedan.

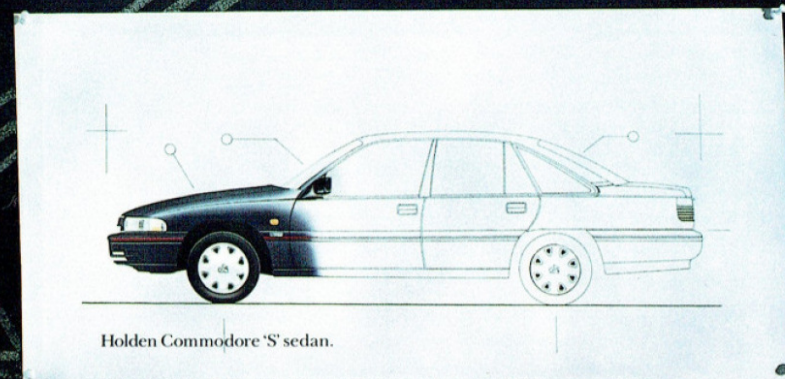

Holden Commodore 'S' sedan.



Holden Commodore Berlina sedan.

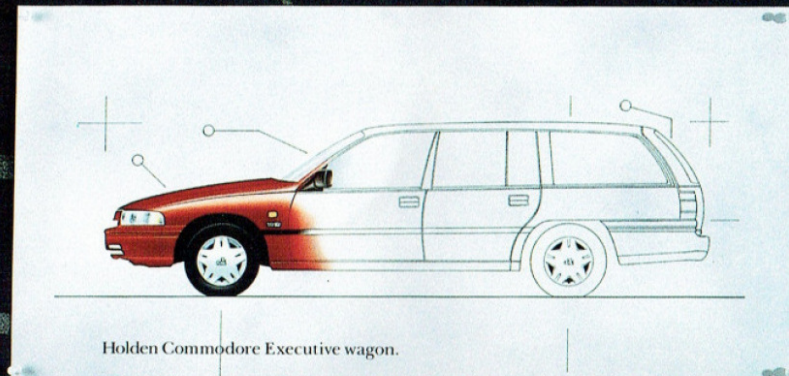

Holden Commodore Executive wagon.

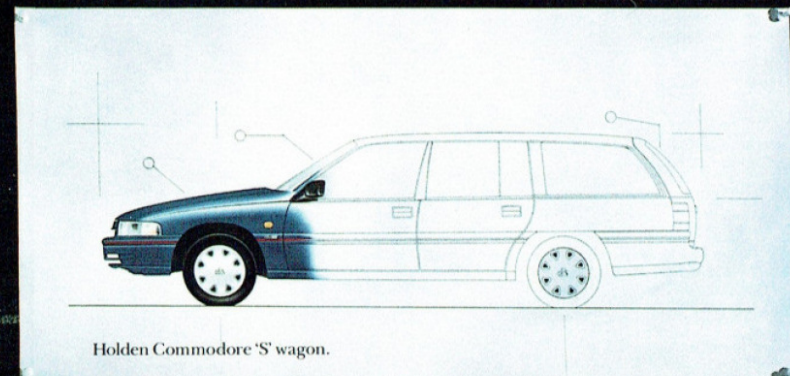

Holden Commodore 'S' wagon.



Holden Commodore Berlina wagon.

Perhaps one reason why Commodore is number one is that there are seven of them, the widest range in Australia.

Which is the one for you?

**HOLDEN SPECIAL VEHICLES.** At HSV, through various aesthetic and engineering modifications, Commodore's world class design is enhanced to build some rather special vehicles, as their name suggests.



It's an organisation dedicated to producing, in very limited numbers, a range of Holdens with an indelible sporting character. For many people, they have become collectors items. And recently they clocked up their 5000th vehicle.

And, being a partnership which combines the worldwide resources of General Motors with the proven race engineering skills of the Tom Walkinshaw

Group of Britain, it's something HSV does very well.

As you would expect, each car complies fully with Australian design rules and carries a full Holden warranty.

**HOLDEN NATIONAL LEASING.** HNL is a company owned by General Motors-Holden's Automotive Ltd. and its dealers which offers a unique, comprehensive and competitive range of leasing and fleet



management packages to Approved Fleets and Customers.

Many other fleet companies may have the use or support of a dealer network. But Holden dealers have put their money where their mouth is by investing in their own fleet company.

By dealing direct, HNL are best placed to offer the most flexible fleet financing deals available for new Commodore and other Holden products. HNL can even build Commodores

to your specifications (to approved fleets only).

What's more, your fleet can be delivered through any one of over 350 Holden dealerships nationwide. Unlike other fleet companies, you get to choose. Most importantly, wherever you do choose to go, all service and maintenance work is charged to HNL at pre-negotiated rates.

They would gladly welcome a chance to submit a

proposition for your consideration. So if you'd like to deal direct and cut out the middleman consult with your Holden Dealer or contact Holden National Leasing directly on (02) 869 2444 or ring toll free on (008) 226 772.

**GMAC.** Factory backed finance from General Motors Acceptance Corporation can be tailored to suit the individual needs of the buyer.





# BUILD YOUR COMMODORE HERE.

S = Standard Feature O = Factory Option A = Dealer Fitted Accessory

	Sedans					Wagons			
	Exec	'S'	'SS'	Berlina	Berlina LX	Exec	'S'	Berlina	Berlina LX
<b>Power Train</b>									
3.8 litre V6 engine	S	S	O	S	S	S	S	S	S
5 litre V8 engine	O		S	O	O	O		O	O
180 kW V8 (Option with IRS & FE2 fitted)	O		O	O	O				
Multi-point fuel injection & engine management computer	S	S	S	S	S	S	S	S	S
5-speed manual transmission (Berlina: removes cruise control)	S	S	S	O	O	S	S	O	O
4-speed auto, with overdrive & fuel-saving torque converter clutch	O	O	O	S	S	O	O	S	S
Limited slip differential	O	O	S	O	O	O	O	O	O
Long range fuel tank (Mandatory with V8)	O	O	S	O	O				
<b>Mechanical</b>									
Power steering, rack & pinion	S	S	S	S	S	S	S	S	S
Stabiliser bars front & rear	S	S	S	S	S	S	S	S	S
Coil springs front & rear	S	S	S	S	S	S	S	S	S
Independent rear suspension (IRS)	O	O	S	O	O				
FE2 Sports suspension tuning (Includes gas pressure rear shock absorbers & heavy duty brakes.) (Not available with Country Pack.) (Executive sedan: option on V8) (Berlina wagon: option on V6)	O	S	S	O	O		S	O	O
Country Pack suspension (not avail. with IRS, or FE2 sports suspension tuning).	O			O	O	O		O	O
Four-wheel power disc brakes	S	S	S	S	S	S	S	S	S
Anti-lock Braking System (ABS) (Option with V8/IRS fitted)	O		O	O	O				
Engine hood gas strut assist	S	S	S	S	S	S	S	S	S
<b>Wheels, tyres</b>									
Steel wheels, 6.00J x 14 & P185/75 R14 89H tyres	S					S			
Steel wheels, 6.00J x 15 & P205/65 R15 95H tyres (Executive: Mandatory with V8 or IRS option unless alloy wheels are chosen)	O	S		S		O	S		S
Alloy wheels, 6.00J x 15 & P205/65 R15 95H tyres (Option with 5-link suspension fitted)		O		O	S		O	O	S
Alloy wheels 7.00J x 15 & P205/65 R15 95H tyres (Option with IRS fitted)		O	S	O					
Full wheel covers	S	S		S		S	S	S	
<b>Exterior</b>									
Engine hood badge	S	S	S	S	S	S	S	S	S
Grille in clear acrylic	S			S	S	S		S	S
- body colour		S	S				S		
Bumpers in body colour	S	S	S	S	S	S	S	S	S
-chrome insert				S	S			S	S
Front bumper air dam			S						
Flush cabin glass	S	S	S	S	S	S	S	S	S
Blackout treatment around side windows		S	S				S		
Black & grey drip and belt mouldings	S			S	S	S		S	S
Metallic paintwork (Berlina: no extra cost)	O	O	O	O	O	O	O	O	O

	Sedans					Wagons			
	Exec	'S'	'SS'	Berlina	Berlina LX	Exec	'S'	Berlina	Berlina LX
Body striping			S						
Exterior mirrors in body colour			S	S	S			S	S
Bodyside mouldings	S	S	S	S	S	S	S	S	S
- wide		S	S	S	S		S	S	S
- body colour		S	S				S		
- body colour and grey				S	S			S	S
- red insert		S	S				S		
- chrome insert				S	S			S	S
Side Skirts			S						
Decklid spoiler, wing type, with high-mounted stop lamp.			S						
Red rear decor panel	S	S	S	S	S				
Foil accent lines on rear, red		S	S						
- anthracite				S	S				
Rear skirt in body colour			S						
Twin low restriction exhausts (Option as part of IRS option)	O	O	S	O	O				
Twin exhaust outlets (Option as part of 165 kW V8 & IRS option package)	O		S	O	O				
Black exhaust outlet styling	S	S	S	S		S	S	S	
- chromed (Option as part of IRS option)	O/A	O/A		O/A	S	A	A	A	S
Wagon tailgate exterior moulding								S	S
S pack identification		S					S		
SS identification			S						
LX identification				S					S
Formula styling pack: front air dam, side skirts, rear spoiler with lamp, formula grille, rear skirts and decal	A	A		A	A				
Licence plate frames	A	A	A	A	A	A	A	A	A
<b>Driver/Passenger</b>									
Two spoke soft feel steering wheel	S	S		S	S	S	S	S	S
- four spoke			S						
Auto transmission T-bar shift	O	O	O	S	S	O	O	S	S
Auto transmission column shift (With "bucket/bench" seating system)	O					O			
Illuminated ignition	S	S	S	S	S	S	S	S	S
Remote boot release	S	S	S	S	S				
- electric operation				S	S				
Remote fuel door release	S	S	S	S	S	S	S	S	S
Remote exterior mirrors, power	S	S	S	S	S	S	S	S	S
Intermittent windscreen wipers	S	S	S	S	S	S	S	S	S
- variable				S					S
- vehicle speed sensitive intermittent				S					S
Tailgate window wiper/washer						S	S	S	S
Electric rear window demister	S	S	S	S	S	S	S	S	S
- auto-off timer				S					S
Digital clock in radio	S	S	S	S	S	S	S	S	S

	Sedans					Wagons			
	Exec	'S'	'SS'	Berlina	Berlina LX	Exec	'S'	Berlina	Berlina LX
Electronic cruise control (Fitted only on auto transmission)	O/A	O/A	O/A	S	S	O/A	O/A	S	S
Cellular car phone	A	A	A	A	A	A	A	A	A
Multifocal dual pocket quartz halogen headlamps	S	S	S	S	S	S	S	S	S
Headlamps auto off					S				S
- programmable auto off delay					S				S
Foglamps			S						
Trip computer					S				S
- odometer					S				S
- trip distance					S				S
- speed warning (setting adjustable)					S				S
- instantaneous fuel consumption					S				S
- distance to empty					S				S
- average speed					S				S
- average fuel consumption					S				S
- elapsed trip time					S				S
- fuel used					S				S
- calibration (fuel & distance)					S				S
Tachometer (Mandatory option with V8)	O	S	S	S	S	O	S	S	S
Coolant temperature gauge	S	S	S	S	S	S	S	S	S
Variable instrument dimming					S				S
Warning lamps include brake failure	S	S	S	S	S	S	S	S	S
- Anti-lock Braking System (ABS) failure and check on engine start (As part of ABS option)	O		O	O	O				
- parking brake 'on'	S	S	S	S	S	S	S	S	S
- parking brake on while car moving (Lamp & chime)					S				S
- temperature					S				S
- low fuel					S				S
- Speed warning, adjustable in trip computer setting (Lamp & chime)					S				S
- oil pressure	S	S	S	S	S	S	S	S	S
- alternator	S	S	S	S	S	S	S	S	S
- check engine	S	S	S	S	S	S	S	S	S
- headlamps left on	S	S	S	S	S	S	S	S	S
- rear demister on	S	S	S	S	S	S	S	S	S
- foglamps on			S						
- rear lamp failure					S				
Body computer co-ordination of electrics, with system fault self-diagnosis					S				S
<b>Sound System</b>									
AM/FM stereo electronic tune radio	S	S	S	S	S	S	S	S	S
Automatic station store memory	S	S	S	S	S	S	S	S	S
Local/Distant selector switch	S	S	S	S	S	S	S	S	S
Dolby noise reduction		S	S	S	S		S	S	S
Separate bass & treble controls		S	S	S	S		S	S	S

	Sedans					Wagons			
	Exec	'S'	'SS'	Berlina	Berlina LX	Exec	'S'	Berlina	Berlina LX
Cassette player	S	S	S	S	S	S	S	S	S
- auto reverse	S	S	S	S	S	S	S	S	S
- music search		S	S	S	S		S	S	S
- metal tape equalisation		S	S	S	S		S	S	S
Compact disc player (10 discs)	A	A	A	A	A	A	A	A	A
Twin speakers, total 14 watts	S					S			
Four speakers, total 28 watts		S	S	S	S		S	S	S
Front/rear fader control knob		S	S	S	S		S	S	S
Power antenna auto (full up/down)	A	A	A	S	S	A	A	S	S
- with height adjust (Option mandatory with cruise control)	O	O	O	S	S	O	O	S	S
- driver pre-setting for max. height					S				S
- auto retract with remote control key					S				S
<b>Seating</b>									
Seat trim in woven cloth	S	S	S			S	S		
- sports design		S	S				S		
- velour				S	S			S	S
Sheepskin bucket seat covers	A	A	A	A	A	A	A	A	A
"Bucket/bench" seating system. (Optional at no extra cost. Avail with V6 & column auto)	O					O			
Bucket seats	S	S	S	S	S	S	S	S	S
- extra support in seat cushion			S						
High rise centre console armrest	S	S	S	S	S	S	S	S	S
Front seat headrests	S	S	S	S	S	S	S	S	S
- height adjust	S	S	S	S	S	S	S	S	S
- cloth		S	S	S	S		S	S	S
- padded		S	S	S	S		S	S	S
Bucket seat back recline	S	S	S	S	S	S	S	S	S
Driver's seat height adjustable	S	S	S	S	S	S	S	S	S
Driver's seat lumbar support		S	S	S	S		S	S	S
Passenger seat lumbar support				S	S			S	S
Plus 2 seat						A	A	A	A
Rear seat centre fold-away tray	S	S	S	S	S				
Rear seat centre armrest				S	S			S	S
<b>Children</b>									
Child seat anchor points	S	S	S	S	S	S	S	S	S
Child seat and cover	A	A	A	A	A	A	A	A	A
Childproof rear door locks	S	S	S	S	S	S	S	S	S
Power window override switch (As part of 4-window power option)			O	O	S			O	S
<b>Cabin Comfort</b>									
Driver's left footrest (3 adjustment positions)	S	S	S	S	S	S	S	S	S
Air conditioning	O/A	O/A	O/A	S		O/A	O/A	S	
Electronic Climate Control, with auto/manual mode				O	S			O	S



	Sedans					Wagons			
	Exec	'S'	'SS'	Berlina	Berlina LX	Exec	'S'	Berlina	Berlina LX
Rear outlet vents (As part of air conditioning or Climate Control option only)	O	O	O	S	S	O	O	S	S
Power windows - front	O	O	O	S		O	O	S	
- front & rear			O	O	S			O	S
- express down driver's window & time delay (Option as part of power window option)	O	O	O	S	S	O	O	S	S
Vanity mirror on passenger's side				S	S			S	S
Centre dome lamp time delay on entry	S	S	S	S	S	S	S	S	S
- instant off on exit when locking by remote control key					S				S
- auto 'off' after 2 hours					S				S
Front reading lamps				S	S			S	S
Rear reading lamps				S	S				
Colour-keyed carpet	S	S	S	S	S	S	S	S	S
- loop pile	S	S	S	S	S	S	S	S	S
- cut pile				S	S			S	S
Carpet floor mats, standard or deluxe types	A	A	A	A	A	A	A	A	A
Padded fabric insert on door trim	S	S	S	S	S	S	S	S	S
- sports style cloth		S	S				S		
- velour				S	S			S	S
Carpet on lower doors				S	S			S	S
Moulded headlining, velour	S	S	S	S	S	S	S	S	S
- colour co-ordinated	S	S	S	S	S	S	S	S	S
Dome lamp in trim colour	S	S	S	S	S	S	S	S	S
Passenger overhead assist handles, rear	S	S	S	S	S	S	S	S	S
- folding				S	S			S	S
Passenger overhead assist handle, front	S	S	S	S	S	S	S	S	S
- folding				S	S			S	S
Timed upper band, flush bonded, laminated windscreen	S	S	S	S	S	S	S	S	S
Windscreen sunshade-front	A	A	A	A	A	A	A	A	A
Weathershield, driver & front passenger window	A	A	A	A	A	A	A	A	A
Tinted side windows	S	S	S	S	S	S	S	S	S
Venetian shades, side windows	A	A	A	A	A	A	A	A	A
Tinted rear window	S	S	S	S	S	S	S	S	S
Venetian shade, rear window	A	A	A	A	A	A	A	A	A
Rear louvre	A	A	A	A	A				
Tailgate dust deflector						A	A	A	A
<b>Storage, Cargo, Towing</b>									
Glovebox, with lamp	S	S	S	S	S	S	S	S	S
Centre console compartment, with carpet	S	S	S	S	S	S	S	S	S
Front door storage bins, full length	S	S	S	S	S	S	S	S	S
Storage pocket rear of driver & passenger seat			S	S	S			S	S
Rear seat centre access to boot	S	S	S	S	S				
Fold-down rear seatback						S	S	S	S
Coat hooks	S	S	S	S	S	S	S	S	S

	Sedans					Wagons			
	Exec	'S'	'SS'	Berlina	Berlina LX	Exec	'S'	Berlina	Berlina LX
Deck lid gas strut assist			S						
Tailgate gas strut assist						S	S	S	S
Carpeted boot floor & spare wheel or wagon cargo area	S	S	S	S	S	S	S	S	S
Tailgate trim panel						S	S	S	S
- with carpet inlay								S	S
Cargo cover						A	A	A	A
Lamp in boot, or wagon cargo area	S	S	S	S	S	S	S	S	S
Heavy duty carry rack						A	A		
Roof rack, gutter mounted	A	A	A	A	A				
Carry bars						A	A		
Aero style roof luggage rack						A	A	S	S
Towing equipment: (Refer specifications)	A	A	A	A	A	A	A	A	A
Superlift shock absorbers	A	A	A	A	A	A	A	A	A
Auto transmission oil cooler (Mandatory with 1590 kg towing kit)	A	A	A	A	A	A	A	A	A
<b>Protection</b>									
Double-sided profile-cut key	S	S	S	S	S	S	S	S	S
Security shields on door locks	S	S	S	S	S	S	S	S	S
Key-operated deadlock	S	S	S	S	S	S	S	S	S
Remote control key	S	S	S	S	S	S	S	S	S
- arms/disengages security ignition disabling system	S	S	S	S	S	S	S	S	S
- arms/disengages alarm system (Accessory as part of alarm accessory)	A	A	A	A	S	A	A	A	S
- operates power door locks	S	S	S	S	S	S	S	S	S
- opens boot					S				
- unlocks tailgate						S	S	S	S
Security ignition disabling system arms automatically	S	S	S	S	S	S	S	S	S
Flashing interior lamp shows vehicle is protected	S	S	S	S	S	S	S	S	S
- positioned on binnacle					S				S
Override key turns off security ignition disabling system	S	S	S	S	S	S	S	S	S
- & alarm (Accessory as part of alarm accessory)	A	A	A	A	S	A	A	A	S
Theft attempt memory and report, including after battery disconnection					S				S
Alarm upgrade kit					A				A
Locking glovebox	S	S	S	S	S	S	S	S	S
Radio/cassette security electronics using PIN	S	S	S	S	S	S	S	S	S
Headlamp guards	A	A	A	A	A	A	A	A	A
Hood guard	A	A	A	A	A	A	A	A	A
Radiator insect screen	A	A	A	A	A	A	A	A	A
Mudflaps (flexible) front & rear	A	A	A	A	A	A	A	A	A
Splashguards (moulded shape) front & rear	A	A	A	A	A	A	A	A	A
Full immersion body corrosion protection	S	S	S	S	S	S	S	S	S
High mount stop lamp, rear window	S	S	S	S	S	S	S	S	S

## VP COMMODORE SPECIFICATIONS

	V6	V8	180kW V8
<b>Engine:</b>	"V" configuration. OHV design with cross flow cylinder heads. Multipoint fuel injection. Engine management computer. 91 octane fuel.		
	Low friction technology. High energy, distributorless, ignition fired by magnetic pulse from crankshaft, via computer. Triple coils. Electric cooling fan.	Stainless steel exhaust manifold. Breakerless high energy electronic ignition system.	Large air intake. High flow air cleaner. Extractor and low-restriction dual exhaust. Recalibrated engine management computer. Knock sensor.
<b>Bore (mm):</b>	97	102	
<b>Stroke (mm):</b>	86	77	
<b>Capacity (cm<sup>3</sup>):</b>	3791	4987	
<b>Compression Ratio:</b>	8.5:1	8.4:1	
<b>Power Din (kW):</b>	127 @ 4800 rpm	165 @ 4400 rpm	180 @ 4600 rpm
<b>Torque Din (Nm):</b>	293 @ 3600 rpm	385 @ 3600 rpm	400 @ 3800 rpm
<b>Transmission Ratios:</b>	<b>5-Speed Manual</b> First: 3.25 Second: 1.99 Third: 1.29 Fourth: 1.00 Fifth: 0.72	<b>5-Speed Manual</b> First: 2.95 Second: 1.94 Third: 1.34 Fourth: 1.00 Fifth: 0.73	
	<b>4-Speed Auto:</b> First: 3.06 Second: 1.63 Third: 1.00 Fourth: 0.70		
<b>Drive:</b>	<b>SS V6:</b> Ratio 3.27:1	<b>SS V8:</b> Ratio 3.08:1	
	Rear, through hypoid differential. <b>Executive, S, Berlina:</b> Ratio 3.08:1		
<b>Fuel Economy: (Litres/100km)*</b>	<b>5-Speed Manual:</b> City cycle: 11.5 (25 mpg) Hwy cycle: 7.4 (38 mpg)	<b>5-Speed Manual:</b> City cycle: 14.5 (19 mpg) Hwy cycle: 9.0 (31 mpg)	
	<b>4-Speed Auto:</b> City cycle: 12.5 (23 mpg) Hwy cycle: 8.0 (35 mpg)	<b>4-Speed Auto:</b> City cycle: 15.0 (18 mpg) Hwy cycle: 9.5 (30 mpg)	
<b>Fuel tank Capacity (litres):</b>	<b>Sedan:</b> 63 <b>Wagon:</b> 68	<b>Sedan:</b> 80 <b>Wagon:</b> 68	
<b>Brakes:</b>	Four wheel disc. Front disc ventilated. Tandem power booster and larger disc. <b>Antilock Braking System (ABS) option:</b> (Avail: when V8 & IRS both fitted.) When wheel speed sensors and computer detect imminent lock-up, brake cylinder pressure is adjusted front & rear to prevent braking skid.		
<b>Wheelbase (mm):</b>	<b>Sedan:</b> 2730 <b>Wagon:</b> 2821		
<b>Wheels &amp; Tyres:</b>	<b>5-link:</b> 6.00J x 14 & P185/75 R14 89H tyres.	<b>5-link:</b> 6.00J x 15 & P205/65 R15 95H tyres.	
	<b>IRS:</b> 6.00 J x 15 & P205/65 R15 95H tyres.		

HOLDEN 12/20 WARRANTY. Every Holden Commodore is covered by the Holden New Vehicle Warranty which covers your vehicle for the first 12 months or 20000 kilometres, whichever occurs first. A word about this catalogue. We have tried to make this catalogue as comprehensive and factual as possible. However, since the time of printing some of the information you'll find here may have been updated. Also, some of the equipment shown or described through this catalogue may have been changed and/or is available at extra cost. And the right is reserved to make changes at any time without notice, in prices, colours, materials, equipment and models. Your Holden Dealer has details, and before ordering, you should ask him to bring you up to date. No Holden Dealer or other person is authorised or permitted to give or make any statement assertion or undertaking in relation to the quality performance characteristics, descriptions or fitness for any purpose of any Holden product which is at variance with any written statement assertion or undertaking on any of these subjects given or made by General Motors-Holden's Automotive Ltd. A.C.N. 006 893 232 or General Motors-Holden's Sales Ltd. A.C.N. 004688831 in its published sales literature, and neither company accepts any liability for any such unauthorised action. General Motors-Holden's Automotive Ltd. and General Motors-Holden's Sales Pty. Ltd. have franchised dealers in many parts of Australia for the sale of service parts and the provision of service to owners of Holden's products. Every endeavour is made to ensure that such dealers carry adequate stocks of service parts, but neither General Motors-Holden's Automotive Ltd. nor General Motors-Holden's Sales Pty. Ltd. makes any promise other than that contained in the New Vehicle Warranty given by General Motors-Holden's Automotive Ltd. that such parts or service facilities will be available at any specific location or at any particular time. Copyright General Motors-Holden's Automotive Ltd. Printed June 1992. AD10448. Printed by Incolour Printing Pty. Ltd., 10 Florence Street, Burwood, Victoria 3125.

	V6	V8	180kW V8		
<b>Suspension:</b>	<b>5-link Suspension:</b> <b>Front:</b> MacPherson Strut, incorporating wet sleeve shock absorbers. Direct acting stabiliser bar. Progressive rate coil springs. <b>Rear:</b> Trailing arm with 5-link location. Panhard rod. Progressive rate coil springs. Double-acting shock absorbers. Stabiliser bar.				
	<b>5-link Country Pack:</b> (Avail: 5-link, excluding Sports). <b>Front:</b> Revised spring and shock absorber rate. Revised stabiliser bar diameter. Increased ground clearance. Engine sump guard. <b>Rear:</b> Revised spring rate. Larger shock absorbers. Revised stabiliser bar diameter. Increased ground clearance.				
	<b>Independent Rear Suspension (IRS), sedan:</b> (Avail: see feature list.) Independent, semi-trailing arm. Progressive rate miniblock coil springs. Double-acting shock absorbers. Stabiliser bar.				
	<b>Sports Suspension Tuning, sedan or wagon:</b> (Avail: 5-link or IRS, excluding Country Pack. See feature list.) <b>Front:</b> Firmer spring rate. Revised stabiliser bar diameter. Reduced ride height. <b>Rear:</b> Firmer spring rate. Revised stabiliser bar diameter. Gas pressure shock absorbers. Fuel tank guard.				
<b>Steering:</b>	Variable ratio rack and pinion. Power assisted with variable assist.				
<b>Track (mm):</b>	<b>5-link: Front/rear:</b> 1451/1478				
	<b>IRS: Front/Rear:</b> 1485/1487				
<b>Turning Circle (m):</b>	10.7 (kerb to kerb)				
<b>Dimensions (mm):</b>	<b>Executive</b>	Length	Width	Height	Ground Clearance
	<b>Sedan:</b>	4891	1812	1403	143
	<b>Wagon:</b>	4910	1812	1422	143
<b>Towing Capacity (kg):</b>	<b>Sedan:</b> 500 with standard towbar. 1200 with load equalising trailer hitch and towbar package. # 1590 with bodyside bracing package, trailer brakes, heavy-duty towbar and equaliser hitch. <b>Wagon:</b> 500, 1200 as sedan. # 1590 with trailer brakes, heavy-duty towbar and equaliser hitch. # Transmission oil cooler mandatory.				
<b>Luggage Capacity (litres):</b>	<b>Sedan:</b> 443 <b>Wagon:</b> 2491 (Rear seat folded down).				
<b>Kerb Weight (kg):</b>	<b>Executive sedan:</b> 1332 <b>Executive wagon:</b> 1380				
<b>Routine Service Intervals (km):</b>	1500, 10,000 then every 10,000.				

\*Fuel consumption figures based on AS2877 tests. These figures are provided to assist you in comparing the fuel consumption of Commodore with other vehicles. The actual fuel consumption will depend, however, on many factors including your driving habits, the prevailing conditions and your vehicle's equipment, condition and use.



