

Holden Caprice



go first class



Driving as you always imagined it



Corners straighten. Distances shorten.  
Heads turn – and stay turned. This is  
driving as you always imagined it. As you  
always wanted it. As you always knew  
it would be.

Supreme power. Sublime handling.  
Superb luxury. Unified, distilled, unleashed.  
The new Holden Caprice embodies  
sports-inspired performance and  
automotive refinement at its absolute,  
breathtaking best.

In a class of its own – with a class all its  
own – this is motoring sophistication for  
a new generation of discerning drivers.  
Its time is now. So is yours. Go all the way.



Most vehicles have a best angle – the new Caprice has 360° of them.

Head on, the sculpted front-end gives the vehicle an immensely powerful on-road presence.

In profile, the new Caprice reveals itself as a body with soul – the short front overhang, sports-styled 18 inch alloys, distinctive wheel arches, sweeping chrome highlights and low slung dynamic proportions.

From behind, the fastback roofline, distinctly tapered boot, LED tail lights and chrome-tipped quad exhaust bring the vehicle to an unforgettable conclusion.

Exterior details also show a degree of flair. Xenon headlamps, with automatic washers, seemingly turn night into day. Sensing rain, the flat blade front wipers activate and adjust according to how heavily it's falling. Side mirror 'puddle' lamps can be switched on when remotely unlocking your vehicle, to ensure you never put a foot wrong when entering the cabin.

It all goes together perfectly. As does the selection of quality accessories, such as the electric sunroof or satellite navigation\* with full-colour mapping, you can use to individualise your new Caprice.

\*Available late 2006

An immensely powerful on-road presence







Impossible to resist

Razor sharp sports dynamics coupled with a true five-star luxury ride. Once, impossible to imagine. Now, courtesy of Caprice's revolutionary new Linear Control Suspension, impossible to resist.

Based on an advanced front and rear multi-link design, with forward mounted variable ratio steering, the new Caprice's suspension architecture gives the vehicle an agility that belies its size.

Supple through the bends. Centred on the open road. No traditional luxury car vagueness or isolation. Just intuitive, precise handling, a palpable road connection and a ride unwavering in grace and composure.

All of it powered by Holden's 270kW\* Generation 4 Alloy V8 engine. Shifted seamlessly by a six-speed automatic transmission with Active Select. And brought to a rapid, controlled stop by powerful, ventilated disc brakes on all four wheels. Every moment of every journey overseen – unobtrusively – by the vehicle's finely calibrated Electronic Stability Program, complete with Traction Control System, Anti-lock Braking System, Electronic Brake Assist and Electronic Brakeforce Distribution.

Perfect for when the road beckons to be driven. Perfect for effortless, long distance touring. Perfect, full stop.

Once you go in first class, there's no turning back.

\*Figure quoted using 98 RON (PULP)



The world's toughest proving ground

To ensure the new Caprice passes the ultimate test – your total driving satisfaction – it was subjected to years of unrelenting examination on the world's toughest proving ground: Australia. And when winter ice proved in short supply, Holden flew the vehicle to Sweden and New Zealand and tested it there as well.

Refined, analysed and refined again, its Linear Control Suspension evolved into the most advanced suspension architecture ever developed for a Holden vehicle. A system totally at home in any of Australia's diverse driving conditions, and unsurpassed by even the most revered European sports luxury sedans.

Safety research was equally exhaustive. Indeed, the new Caprice was crash-tested under virtually every imaginable real world scenario, with a range of crash test dummies representing virtually every size and shape of driver and passenger possible.

All throughout the vehicle's development, no idea was too big and no detail too small. An entire production line was stripped and rebuilt to ensure the narrowest interior fit and finish tolerances in Holden's history. Dozens of tyre compounds were trialled on the test track. And 60 different music genres used to tune the high-end audio system.

And yet impressive as all this may sound, it's still just a sample of what went into creating the new Caprice. So just imagine the enjoyment you'll get from driving it.





### A sleek, urbane aesthetic

The luxury treatment begins before you even set foot in the cabin. One touch of your remote key and your individual preferences take immediate effect. From the side mirror positions to your powered seat settings. Radio station presets to your trip computer personalisation. And once your key is in the ignition, the tri-zone climate control activates to your personal preferences.

Inside, the vehicle's sports pedigree is obvious. The refinement and attention to detail, unmistakable. The lush, dark-coloured ceiling and pillars. The bold aluminium accents. The exquisite 'soft-touch' tailored leather and suede in understated tones. Contrasted, they engender a sleek, urbane aesthetic with a distinct, performance-oriented edge.

For a vehicle of awesome power, there is an audio system to match. Bose, of course. With a six disc CD stacker and 10 speakers – including sub-woofers and roof-mounted centre speaker – it delivers 220 watts of incomparable surround sound.

And while you enjoy audiophile quality music, rear seat passengers can enjoy DVDs on screens incorporated into the back of each front seat headrest.

With so much quality entertainment going on, the new Caprice's theatre lighting – which slowly dims interior lights to a soft, ambient glow – will come as no surprise. Nor the myriad of other thoughtful touches, such as expandable door storage. A sliding centre front armrest. Retractable rear seat cupholders. And a centre fold-down rear seat armrest, complete with storage tray.



## Focus, not excess

The new Caprice's driver-centric dashboard makes you master of all you survey – maximising your road view and placing all essential vehicle information in your immediate line of sight.

From speed and engine revs to real-time trip metrics, audio system status and tyre pressure alerts – plus turn-by-turn street directions, with the optional satellite navigation\* installed – you're in a position to monitor every detail with your eyes ahead for optimal driving control.

The four analogue instruments and three multifunction displays in the primary cluster are supplemented by the high-resolution full colour LCD display in the centre instrument panel – a unit that shows individual climate control settings, the electronic parking sensor display and more, including DVDs, when the vehicle is stationary.

Commonly used functions, such as the integrated hands-free Bluetooth mobile phone system, can be operated via fingertip controls mounted either side of the leather grip steering wheel. Other controls are placed intuitively and, through ergonomic use of satin chrome finishes and tactile rubber grips, operate intuitively. By your side – seat, window and mirror controls. Overhead – lighting and DVD controls, plus climate control and entertainment controls for rear seat passengers.

The vehicle even features night panel illumination, which helps reduce driver fatigue by dimming all interior lighting to leave only the speedometer illuminated. A huge plus for long distance driving after dark.

In the new Caprice, it really is all systems go.

\*Available late 2006





Reassuringly cold to the touch, accents of genuine pressed aluminium give the new Caprice a bold and modern aesthetic.



Up to four times brighter than regular halogen bulbs, xenon headlamps penetrate the distance to improve night driving safety.







The remote controlled DVD player shows DVDs through LCD screens integrated into the back of the front seat headrests, with sound channelled through stereo headsets.



The twin needle stitched seats combine exquisite 'soft-touch' leather trim with micro-perforated leather inserts for optimal comfort and support.



For enhanced occupant safety, the new Caprice features a total of six airbags: dual-stage front airbags, side impact airbags for the driver and front passenger, and side curtain airbags.



Stylish and safety-oriented, the LED fender vents provide highly visible side indication.





The 220 watt Bose surround sound system employs 10 speakers – including sub-woofers and roof-mounted centre speaker – to surround you with audiophile quality surround sound.

The sports-inspired leather wrap gearshift ensures maximum grip when using Active Select to power up or down through the gear range.





# Safety

With stunning on-road performance and all encompassing luxury, goes an unwavering dedication to driver and passenger safety. Inside the Caprice, you are surrounded – literally – by an advanced new multi-layered driver defence system featuring state-of-the-art active and passive safety technology. The former to help prevent collisions; the latter to help prevent injury in the event of a collision.

## Active safety

Up to 200 times a second – that's how often the new Caprice's active safety systems monitor on-road dynamics. Everything from the vehicle's speed, lateral acceleration and rotation, to the steering wheel angle and brakeforce you apply.

When normal tolerances are exceeded, one or more of the following systems initiate integrated – non-intrusive – counter measures to help ensure you retain maximum control of the vehicle.

**Co-ordination of active safety features**  
Be it from the Electronic Stability Program (ESP®) for turning and cornering. The Traction Control System (TCS) that minimises slip when accelerating. Or the Anti-lock Braking System (ABS) with Electronic Brake Assistance (EBA) and Electronic Brakeforce Distribution (EBD) that helps you stop quickly with maximum control. You can expect 360° support from the new Caprice's integrated active safety systems.

**ESP® Electronic Stability Program**  
ESP® constantly compares the vehicle's movements with the steering wheel angle to determine if the vehicle is moving in the direction you intend. If skidding appears imminent, ESP® applies brake pressure to individual wheels as appropriate and, if necessary, trims engine power. This dramatically increases turning and cornering safety, especially in 'evasive action' situations.

**TCS Traction Control System**  
Designed to minimise slippage during acceleration, TCS recognises if either rear wheel has insufficient grip and adjusts drive force and brakeforce accordingly. It reduces wheelspin when accelerating on wet and icy roads, and also in 'split' conditions, such as when a vehicle has two wheels on bitumen and two on a gravel verge.

**ABS Anti-lock Braking System**  
If wheel 'lock up' is detected under forceful braking, ABS momentarily reduces brake pressure at the affected wheel. This improves braking efficiency – reducing stopping distances on most surfaces – and helps maintain steering control to ensure the vehicle remains directionally stable.

**EBA Electronic Brake Assist**  
In emergency braking situations, few drivers actually press the brake pedal firmly enough to achieve maximum braking performance. EBA is designed to sense how fast you press the brake pedal in an emergency, and maximise braking pressure to optimise braking performance.

**EBD Electronic Brakeforce Distribution**  
When a vehicle brakes, weight transfers to the front wheels. By regulating the brakeforce applied to each wheel, EBD ensures optimal balance between front and rear brakes, which helps minimise stopping distances.

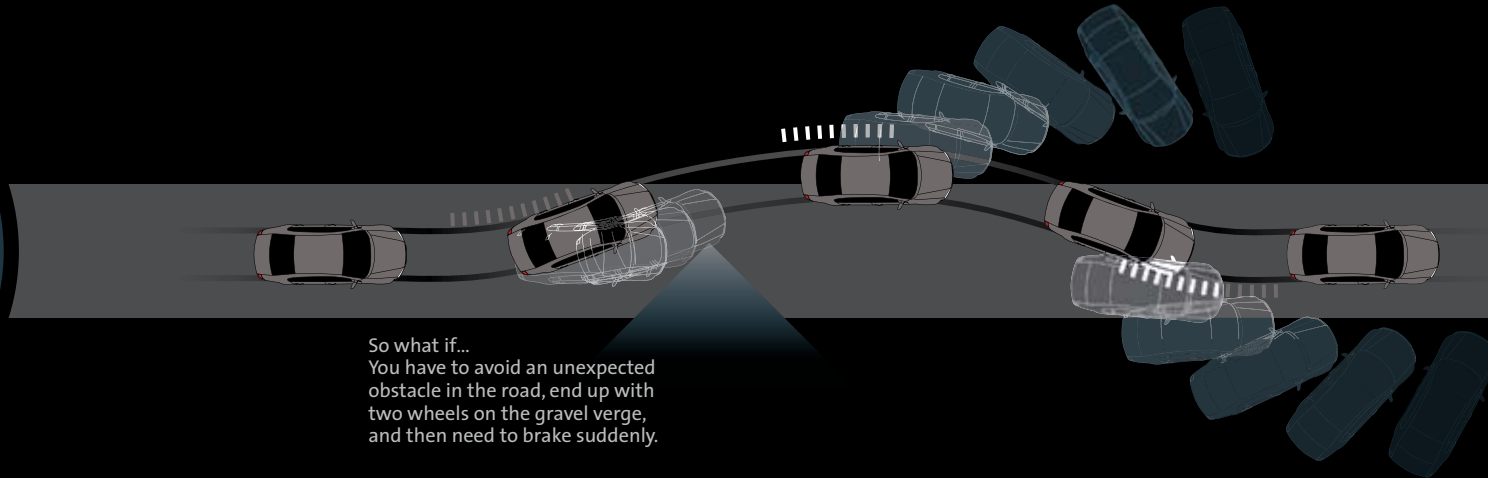
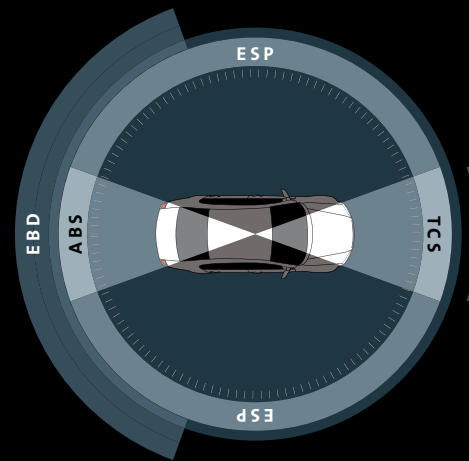

So what if... You have to avoid an unexpected obstacle in the road, end up with two wheels on the gravel verge, and then need to brake suddenly.

ESP® brakes the left rear wheel momentarily to avoid understeer.

TCS reduces torque to the left rear wheel to reduce slip.

ESP® brakes the right front wheel momentarily and reduces engine power to correct oversteer.

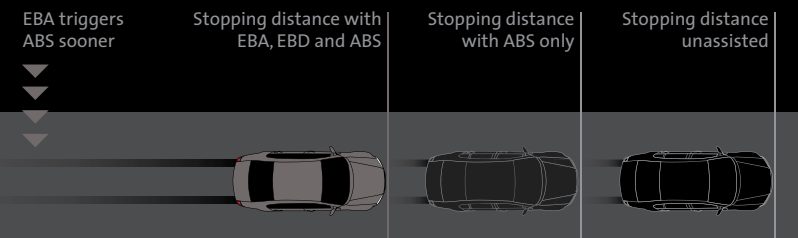

Sensing an emergency stop, EBA initiates maximum brakeforce, ABS maximises brake efficiency and EBD maintains optimal front/rear brake balance.

## Passive safety

A collision is a contest between impact energy and your vehicle's safety features. You want everything possible on your side.

That's why the new Caprice features Holden's Adaptive Occupant Restraint System – which includes dual-stage front airbags for driver and front passenger – as well as multiple load paths to help channel impact energies and a safety cell reinforced with ultra high strength steel.

Most impressive of all, in a frontal crash, the new Caprice can automatically initiate and co-ordinate all on-board passive safety measures in an incredible 90 milliseconds (ms) – about the time it takes to snap your fingers.

**Co-ordination of passive safety features**  
To protect occupants from collision forces, Holden's Adaptive Occupant Restraint System uses forward and side sensors to detect the severity and direction of a collision, triggering the appropriate passive safety measures.

**Safety cell, crumple zones and load paths**  
In frontal and rear collisions, impact energy is absorbed by crumple zones and channelled away from the driver and occupants via multiple load paths.

The new Caprice's multiple load path strategy is also integral to side impact protection, as is the vehicle's safety cell. Strategically reinforced with steel seven times stronger than normal, it offers significantly increased protection against passenger safety cell intrusion across all vehicle sides.

- crash sensors
- 1 driver's front airbag
- 2 passenger's front airbag
- 3 side impact airbags
- 4 curtain airbags
- 5 front crumple zone
- 6 passenger safety cell
- 7 rear crumple zone

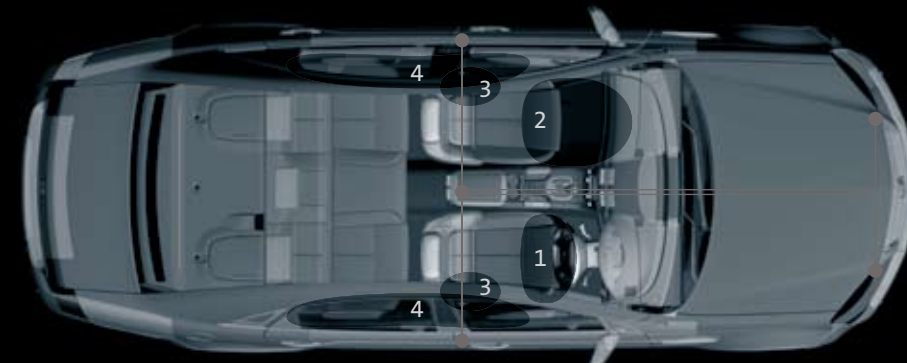
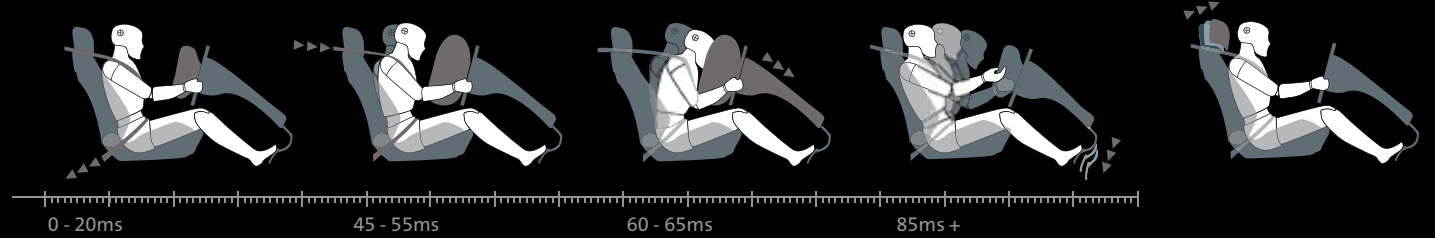

**Pyrotechnic seatbelt pretensioners**  
When an impact of sufficient severity is detected, small explosive charges force the front seatbelt buckles towards the cabin floor. This tightens the seatbelts and holds both driver and front passenger firmly against their seats.

**Dual-stage front airbags**  
For maximum protection in certain frontal collisions, the front airbags for driver and front passenger inflate in two stages, according to the impact severity and their respective seat positions.

The 60 litre driver airbag can fully inflate in 45 milliseconds. The front passenger airbag, which is oversized, can inflate to a full 125 litres in just 55 milliseconds.

**Curtain and side impact airbags**  
Side curtain airbags provide head and upper body protection for front passengers and left and right rear passengers in certain side-on collisions. Side impact airbags provide additional chest and thorax protection for the driver and front passenger.

**Load limiters**  
Following airbag deployment, load limiters unspool the front seatbelts incrementally to minimise the risk of seatbelt related injury.

**Steering and brake pedal safety**  
In severe frontal impacts, the steering wheel can collapse bi-directionally and, to prevent leg injury, the brake pedal detaches.

**Active front seat head restraints**  
In rear collisions, active head restraints tilt forward, closing the distance between your head and your seat's headrest, thus reducing the risk of whiplash injury to the neck.

**Emergency shutdown**  
Following a collision where airbags or seatbelt pretensioners have deployed, on-board safety systems will turn off the engine and fuel pump, unlock the doors and turn the hazard and interior lights on, if battery power is available.



ESP® is a registered trademark of Daimler Chrysler AG



The new Caprice is a vehicle driven by innovation. From the futuristic component synchronisation and optional on-board telematics, to the sublime convenience of integrated Bluetooth connectivity.

## Holden Assist telematics\*

Optional on the new Caprice, telematics enables vehicles to send and receive data – and have their position pinpointed at any time – via integrated GSM mobile phone network and global positioning satellite technology.

Owners of telematics-equipped vehicles can take advantage of Holden Assist, a subscription-based interactive security system that provides on-board assistance 24/7, based on one of three service levels:

### Holden Assist Secure

- If stolen, Holden Assist can locate and track your vehicle, and working with police, safely immobilise the engine via remote technology.

### Holden Assist Ultra

All Secure level features, plus:

- If an airbag is deployed, the system notifies an operator who will attempt to speak with the driver. If there is no response, emergency services are notified.
- If keys are locked in the vehicle, an operator can validate the owner's identity, then unlock the doors remotely.
- In an emergency, the driver can press the SOS button to speak with an operator, who will locate the vehicle and send emergency services if required.
- If roadside assistance is required, on the press of a button the vehicle is located and assistance despatched.
- If the vehicle battery is low, the system notifies an operator who will attempt to speak with the driver.

### GM FleetView

Designed for businesses with on-the-road employees, fleet telematics are designed to increase driver and fleet manager productivity, while encouraging better driver behaviour and greater adherence to occupational health and safety practices. For full details on fleet telematics, call GM Fleet Customer Assistance on 1300 559 696.



## Satellite navigation\*

Turn-by-turn satellite navigation is optional on the new Caprice. Operated via the scroll wheel and buttons mounted on the steering wheel, the system provides visual directions via the centre driver display, full mapping via the colour LCD screen in the centre console, and audible directions via the vehicle's audio system.

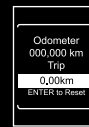

## Trip computer

The on-board trip computer is controlled via the scroll wheel and buttons mounted on the steering wheel. Trip data is shown on the electronic driver display. Depending upon your preferences, the information displayed can include:

- trip distance
- average speed
- average fuel usage
- distance to go
- time to go
- range
- odometer reading
- speed
- overspeed warnings (visual and audible)
- underverspeed warnings (visual and audible)
- rest reminders every two hours of driving time

It is even possible to track two trips simultaneously, for example a short day trip within a long interstate trip.

## Personalisation

The new Caprice lets you tailor a range of vehicle functions to your individual liking, including:

- Departure lighting: when locking your vehicle remotely at night, the headlamps will remain on and turn off automatically after 30, 60, 90 or 180 seconds.
- Approach lighting: when unlocking your vehicle remotely at night, the headlamps can automatically come on for 60 seconds, or not at all.
- Multi-stage unlocking: when unlocking your vehicle remotely, you can have all four doors unlock at once, or the driver's door on the first press and the remaining doors on the second.

## Priority flip key

The new Caprice comes with two priority keys, which store individual driver preferences, such as trip computer display options, climate control settings and radio station presets. Your preferred settings take effect the moment you unlock your car remotely.

## Component synchronisation

To deter theft, the audio system, instrument cluster and other key components are electronically synchronised to the vehicle in which they were originally fitted. Unauthorised removal and re-use disables both the vehicle from which a component was taken, and the vehicle into which it is fitted.

## Night panel

At night, interior lighting can be dimmed to leave only the speedometer illuminated. Should your attention be required, the relevant instrument lights up. This reduces driver distraction and fatigue, making it perfect for night driving in the country.

## HID xenon headlamps

The new Caprice's High Intensity Discharge (HID) headlamps each contain a small glass bulb filled with xenon gas. Passing electric current through the gas results in an immensely concentrated and intense beam of light, significantly brighter than traditional halogen lamps of similar size.

## Front and Rear Park Assist

The electronic parking sensors on the new Caprice provide visual and audible aids when parking the vehicle. Appearing on the centre display, the visual display shows both the direction and distance of nearby objects.



## Bluetooth

Integrated Bluetooth technology lets you take and make calls, hands-free, at the touch of a button with compatible Bluetooth mobile phones. The controls are conveniently mounted on your steering wheel, the microphone is housed in the roof console, and the call is heard over the audio system – which automatically mutes whatever is playing at the time. No wires. No cradles. No headsets.



## MP3 player connectivity

The audio system includes an auxiliary input jack for external music sources, such as MP3 players.



## Tri-screen DVD Player

A remote control operated, tri-screen DVD system with stereo headphones is standard on the new Caprice. Integrated into the cabin ceiling, the system plays DVDs for rear passengers via high-resolution LCD screens incorporated into each front seat headrest. The front centre console LCD screen also displays DVDs when the vehicle is stationary.

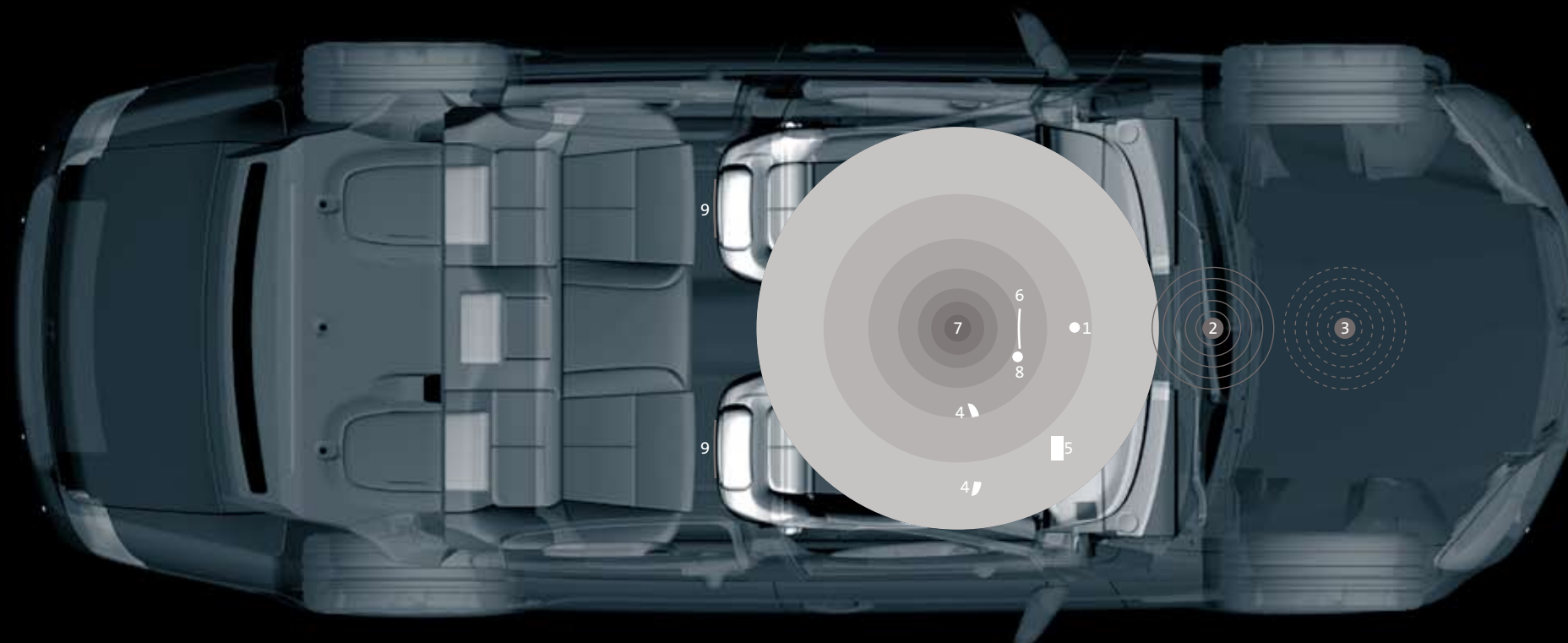

## Location of features when fitted

- 1 Holden Assist SOS button located on rear vision mirror.
- 2 Telematics GSM network transmitter.
- 3 Satellite navigation GPS transmitter.
- 4 Steering wheel mounted scroll wheel and buttons for controlling satellite navigation, trip computer, audio system, personalising settings and hands-free phone calls using Bluetooth.
- 5 Centre driver display for messages such as satellite navigation directions, trip computer data and more.
- 6 Centre console screen displays full audio system data and full-colour mapping when satellite navigation is fitted.
- 7 Microphone for telematics communications and hands-free Bluetooth mobile phone calls.
- 8 Audio system auxiliary input jack for connecting MP3 players.
- 9 Integrated dual DVD screens.



# Power

## Generation 4 Alloy V8

Brutal, road dominating power. Supremely responsive performance. Endless satisfaction. When you go with the 6.0 litre Generation 4 Alloy V8 engine, you never look back. Delivering an awesome 270kW\* of power and 530Nm\* of torque, it features:

- Electronic Throttle Control for immediate response and maximum performance
- Lightweight alloy construction, enabling a more supple front suspension and smoother ride
- A one piece induction system for smooth airflow and superior breathing

### 6-speed automatic transmission with Active Select

Marshalling that menacing power into an exceptionally refined driving experience is a perfectly mated 6-speed automatic transmission with Active Select. Delivering improved acceleration and greater fuel economy, this slick, world-class transmission enables one touch switching from automatic to manual shifting, for those times when you feel like true 'hands-on' driving.



## Alloytec V6

The new Caprice can also be fitted with the 3.6 litre High Output Alloytec V6 engine. One of the most advanced production engines ever manufactured in Australia, it generates a potent 195kW of power and 340Nm of torque, with features that include:

- Alloy construction for power and strength
- Variable intake manifold for outstanding performance and reliability
- Double overhead camshaft for improved performance
- Four valves per cylinder to help the engine breathe better for greater performance
- Continuously variable valve timing for enhanced performance and responsiveness

### 5-speed automatic transmission with Active Select

Teamed with the optional Alloytec High Output V6 engine, the 5-speed automatic transmission with Active Select combines outstanding driveability and response with smooth, crisp – almost seamless – gear changes. Plus, the option to shift manually anytime you choose.

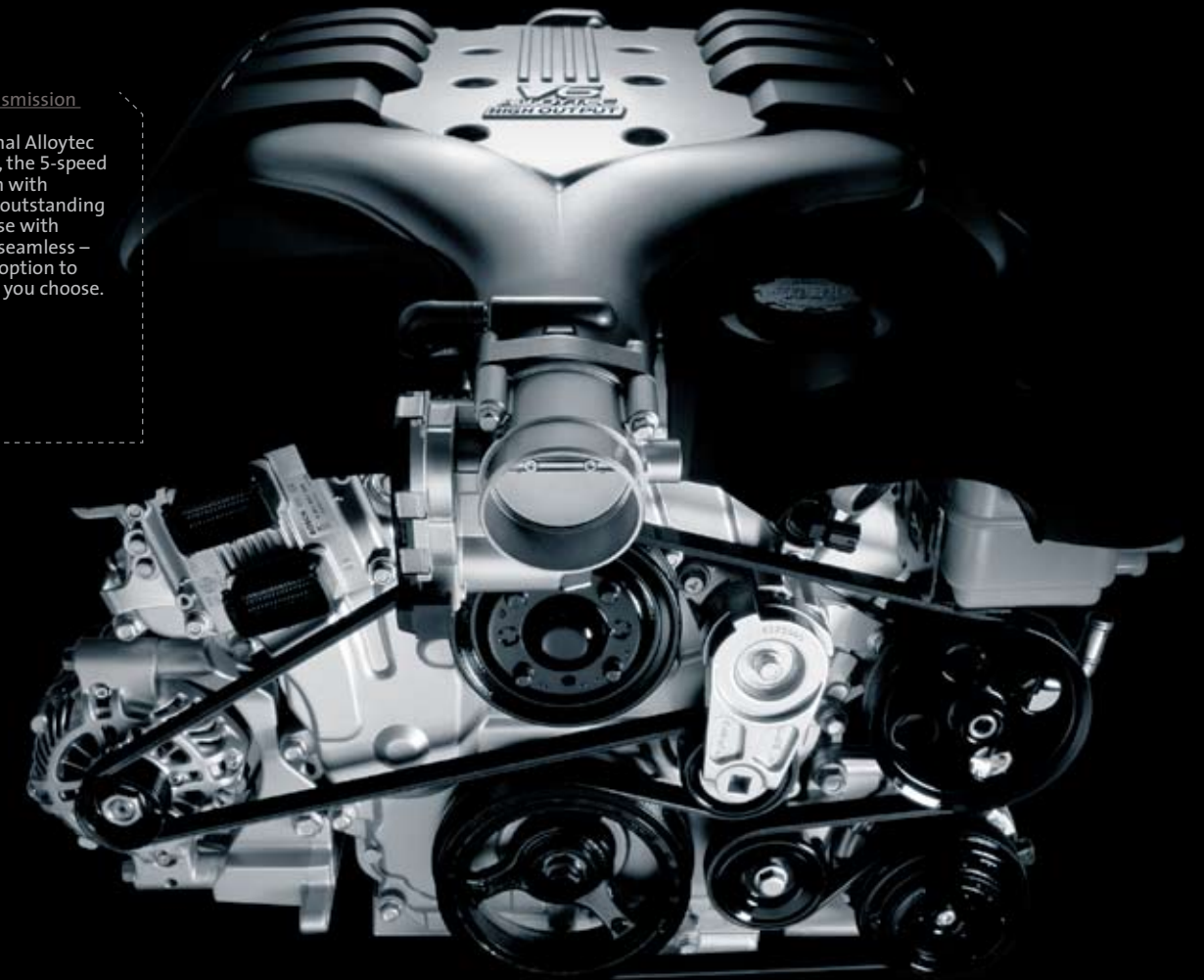



# features

| engine  | exterior/interior  | exterior/interior (continued)   | safety/security   |
|---|--|---|---|
| <b>engine and transmission</b>                                | <b>wheels</b>  | <b>driver (continued)</b>   | <b>occupant safety</b>  |
| 270kW,* 6.0 litre Generation 4 Alloy V8 engine                | 18" x 8" alloy wheels. 245/45 R18 96V tyres  | Tyre pressure monitor   | Dual-stage front airbags for driver and front passenger   |
| 6-speed automatic transmission with Active Select (V8 only)   | Full size alloy spare wheel  | Service reminder. Appears 1,000km before service is due   | Side impact airbags for driver and front passenger  |
| 195kW, 3.6 litre High Output Alloytec V6 engine               |  | Sound system able to accommodate compatible mobile phone with phone kit fitted. Auto mute when phone is in use  | Side curtain airbags  |
| 5-speed automatic transmission with Active Select (V6 only)   | <b>exterior</b>  | Bluetooth mobile phone connectivity   | Front seatbelts with load limiters and pyrotechnic pretensioners  |
| Limited Slip Differential                                     | Front fog lamps  | Satellite navigation (available late 2006)  | Front seatbelt height adjustable  |
|   | Bi-Xenon headlamps   |   | Rear seat child restraint anchor points (3)   |
| <b>control and handling</b>                                   | LED tail lamps   | <b>entertainment</b>  | Active front seat head restraints to help reduce risk of whiplash injury in a collision from behind   |
| Linear Control Suspension                                     | Exterior mirrors with 'puddle' lamps and position memory                                   | Bose premium audio system featuring ten speakers, including sub-woofers. Total 220 watts  | <b>security</b>   |
| Sports luxury suspension. Reduced ride height. Firmer springs | Dual exhaust (V6 only)   | 6 disc CD player. MP3 compatible  | Remote control priority flip key:   |
| Electronic Stability Program (ESP®) incorporating:            | Quad exhaust (V8 only)   | Speed dependent volume control  | Operates central locking  |
| Anti-lock Braking System (ABS)                                | Chrome body side mouldings   | DVD player with dual LCD screens. Remote control. Front LCD screen also plays DVD when vehicle is stationary  | Operates interior lighting. Time delay on entry. Automatic illumination when engine turned off  |
| Electronic Brakeforce Distribution (EBD)                      | Chrome highlight exterior door handles   | Headsets for rear passengers, two pairs   | Operates exterior lamps, to show location of car at night   |
| Electronic Brake Assist (EBA)                                 | <b>driver</b>  | Multi-mode function to allow headset choice of radio, CD or DVD   | Enables/disables alarm system   |
| Traction Control System (TCS)                                 | Steering wheel height and reach adjust   | Rear overhead console remote control of audio and DVD functions   | Unlocks boot  |
|   | Leather wrap steering wheel  | Rear audio visual auxiliary jack  | Disables remote boot release button in glovebox (when locking)  |
|   | Leather wrap gear selector   | Diversity antenna: FM   | Horn sounds if front door is ajar when remote locking   |
|   | Multifunction steering wheel, featuring illuminated controls for:                          | <b>seating</b>  | Sound system and DVD player operate only in original vehicle  |
|   | Sound system   | 'Soft-touch' leather seat trim with leather door trim inserts   | Holden Assist telematics (available late 2006)  |
|   | Trip computer  | 10-way electric adjustment of front seats: Slide. Cushion tilt. Height. Recline. Lumbar   | <b>road safety</b>  |
|   | Bluetooth phone  | Driver's seat memory for 3 driver positions (memory excludes lumbar position)   | Emergency mode after seatbelt pretensioners are triggered. On-board computer turns engine and fuel pump off. Unlocks doors. Turns hazard lights and interior lamp on (if battery power available) |
|   | Satellite navigation (where fitted, available late 2006)                                   | <b>cabin comfort</b>  | • standard<br>○ optional  |
|   | Multifunction driver display, featuring:   | Tri zone electronic climate control: driver, front passenger and rear   |   |
|   | Trip computer information  | 6.5" multifunction colour LCD screen. Displays stereo and climate control information. DVD player and satellite navigation compatible (where fitted, available late 2006) |   |
|   | Sound system information   | Power windows. Driver and front passenger windows express up and down   |   |
|   | Priority flip key for 2 people. When unlocking car it automatically restores settings for: | Electric tilt and slide sunroof   |   |
|   | Climate control  | Front centre sliding armrest with leather trim  |   |
|   | Radio presets  | Rear seat centre armrest with storage compartment   |   |
|   | Trip computer  | Vanity mirror, driver and front passenger. Illuminated with cover   |   |
|   | Speed warning  | Sunglasses holder (except where sunroof fitted)   |   |
|   | Headlamp and interior lighting time delay options  | Chrome finish interior door handles   |   |
|   | Driver's seat adjustment and exterior mirror position                                      | Passenger overhead assist handles; rear with coat hooks   |   |
|   | Cruise control   | Front and rear reading lamps  |   |
|   | Front and Rear Park Assist   | Door entry lamps  |   |
|   | Power exterior mirrors. Heated, auto off   | <b>storage and cargo</b>  |   |
|   | Electro-chromatic interior rear vision mirror reduces headlamp glare automatically         | Twin cup holders in front centre console and rear seat  |   |
|   | Passenger side exterior mirror dips when reverse gear selected to show low-level hazards   | Centre console storage compartment  |   |
|   | Rain sensing wipers  | Auxiliary power socket in console and boot  |   |
|   | Automatic headlamp mode. Switches on at twilight or low light. Manual override             | Fold down rear seat centre 'ski' hatch for long loads   |   |
|   | Headlamps auto off feature (variable delay)  | Luggage net (adjustable) in boot to keep small items in place   |   |
|   | Trip computer with triple display including:   |   |   |
|   | Average speed  |   |   |
|   | Odometer/tripmeter   |   |   |
|   | Distance/time to go  |   |   |
|   | Instantaneous/average fuel consumption   |   |   |
|   | Fuel used/range  |   |   |
|   | Visual and audible speed warning   |   |   |
|   | Tracks two trips simultaneously (eg. short day trip within long interstate trip)           |   |   |
|   | Rest reminder warning after a nominated length of continuous driving (adjustable setting)  |   |   |

\* Figure quoted using 98 RON (PULP)



technical specifications

|                                  | 195kW, 3.6 litre High Output Alloytec V6 engine  | 270kW,* 6.0 litre Generation 4 Alloy V8 engine  |                                     | Caprice   |
|----------------------------------|--|---|-------------------------------------|---|
| Engine                           | 3.6L 60-degree Double Overhead Cam V6 with 4 valves per cylinder. Twin knock control sensors with individual cylinder adaptive control. On-board diagnostics | 6.0L 90-degree OHV V8. Cross flow cylinder heads. Twin knock control sensors. On-board diagnostics              | Recommended petrol octane rating    | 91 RON ULP<br>Note that using 95 RON (PULP) or higher may result in improved engine performance and economy   |
|                                  | Continuously variable camshaft phasing for inlet and exhaust cams. Variable Intake Manifold (VIM)  | Central plenum with individual symmetrical runners  | Petrol tank capacity (L)            | 73  |
|                                  | High energy distributorless ignition. Solid state, voltage-driven Direct Fire ignition, coil-on-plug with on-board igniter                                   | High energy, distributorless ignition. Solid state Direct Fire ignition, coil near plug with integrated igniter | Brakes                              | Four wheel disc. Ventilated discs – front and rear. Twin piston alloy front caliper, single piston alloy rear caliper   |
| Capacity (cc)                    | 3564   | 5967  | Electronic Stability Program (ESP®) | Incorporating: Anti-lock Braking System (ABS), Electronic Brakeforce Distribution (EBD), Electronic Brake Assist (EBA), Traction Control System (TCS)   |
| Compression ratio (:1)           | 10.2   | 10.4  | Suspension                          | Front: MacPherson strut. Direct acting stabiliser bar. Progressive rate coil springs<br>Rear: Multi-Link Independent Rear Suspension (IRS) Semi-trailing arm. Progressive rate mini-block coil springs. Stabiliser bar  |
| Power (ECE, kW)*                 | 195kW @ 6500rpm  | 270kW* @ 5700rpm  | Sports luxury suspension            | Front: Firmer spring rate. Reduced ride height<br>Rear: Firmer spring rate. Gas pressure dampers  |
| Torque (ECE, Nm)#                | 340Nm @ 2600rpm  | 530Nm* @ 4400rpm  | Steering                            | Variable ratio rack and pinion  |
| Exhaust system – stainless steel | Dual exhaust   | Quad exhaust  | Track (mm)                          | Front: 1592<br>Rear: 1608   |
| Engine cooling                   | Electric Cooling Fans  | Electric Cooling Fans   | Turn circle (kerb to kerb, m)       | 11.6  |
| Gear ratios                      | 5sp Auto   | 6sp Auto  | Wheelbase (mm)                      | 3009  |
| 1st                              | 3.42   | 4.03  | Exterior design dimensions (mm)     | Length                      Width (excluding mirrors)                      Height                      Ground clearance   |
| 2nd                              | 2.21   | 2.36  |                                     | 5160                      1899                      1480                      110   |
| 3rd                              | 1.60   | 1.53  | Interior design dimensions (mm)     | Leg                      Shoulder                      Head                      Hip  |
| 4th                              | 1.00   | 1.15  |                                     | Front                      1071                      1501                      985                      1439  |
| 5th                              | 0.75   | 0.85  |                                     | Rear                      1098                      1500                      965                      1472   |
| 6th                              | –  | 0.67  | Boot volume (L)                     | 535   |
| Final drive ratio                | 2.92   | 2.92  | Towing (kg)                         | Maximum towing: 2100. Holden approved 1200, 1600 and 2100 towing equipment is available. See your Holden Dealer for details.  |
|                                  | #Maximum figures as per ECE regulations<br>*Figure quoted using 98 RON (PULP)  |   | Service                             | The first inspection is due at 3,000km or 3 months (whichever occurs first). The first service is due at 15,000km or 12 months (whichever occurs first). Thereafter, at every 15,000km or 12 months since the last service (whichever occurs first). Additional services are required under certain driving conditions, such as when towing (refer to owner's handbook). Maintenance-free long life, accessory drive belt with automatic tensioner. Dual belt on V8. Holden Dealer 'Tech 2' computerised analysis available for engine management system. |



vehicle dimensions

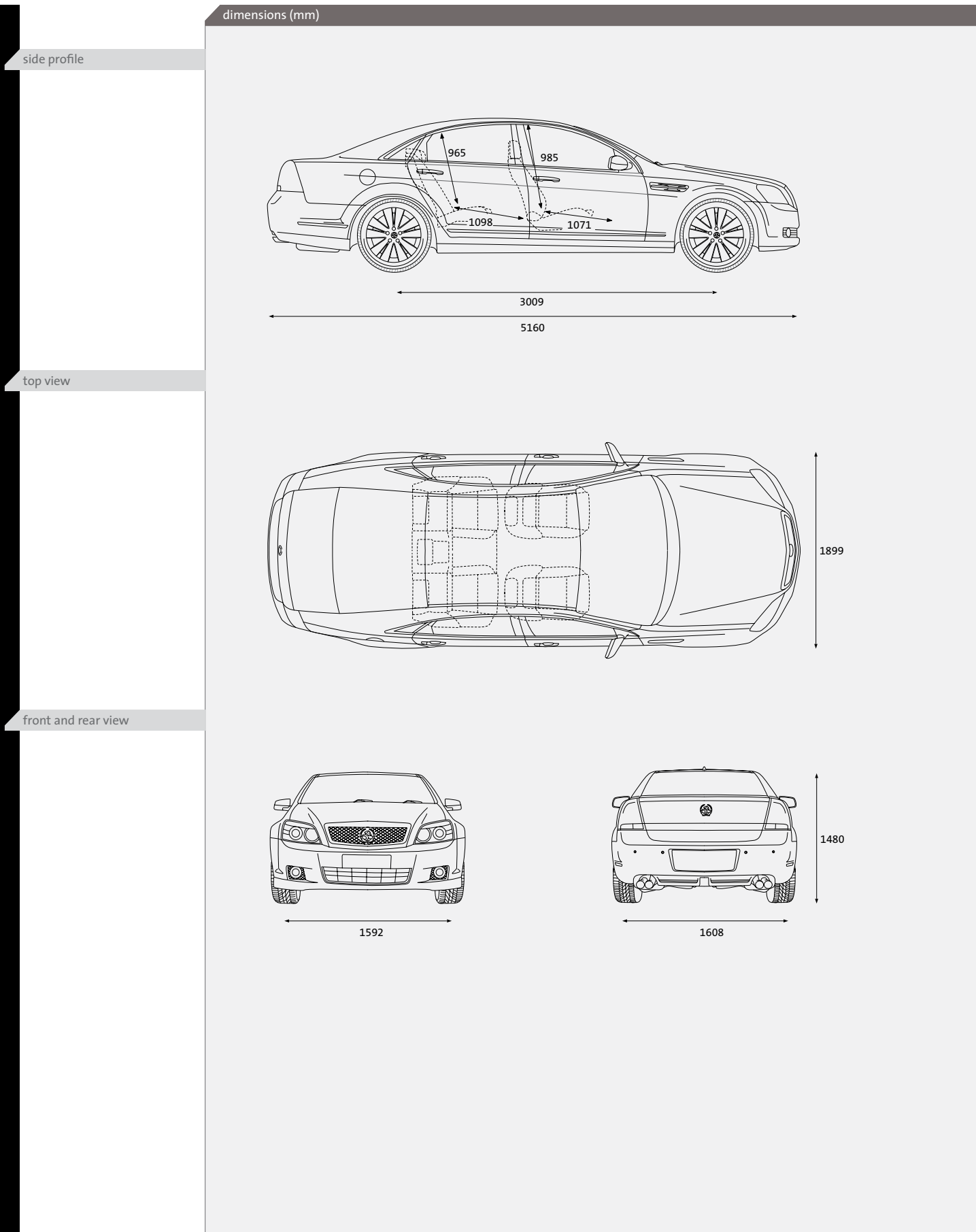

trims and colours

Caprice

| exterior colours |         |           |             |              |        |             |       |       |  | interior trim |                     |  |
|------------------|---------|-----------|-------------|--------------|--------|-------------|-------|-------|--|---------------|---------------------|--|
| Heron White      | Phantom | Sandstorm | Red Passion | Vespers Blue | Nickel | Odyssey     | Evoke | Crema |  |               | Onyx leather        |  |
| •                | •       | •         | •           | •            | •      | •           | •     | •     |  |               | Light Urban leather |  |
| leather trim     |         |           |             |              |        |             |       |       |  |               |                     |  |
|                  |         |           |             |              |        |             |       |       |  |               |                     |  |
| Onyx             |         |           |             |              |        | Light Urban |       |       |  |               |                     |  |

Variations between colours shown and actual paint colours/interior trim colours may occur due to the printing process. Actual vehicle colours may appear different under certain light conditions. Trim patterns are not to scale. Indicative only.

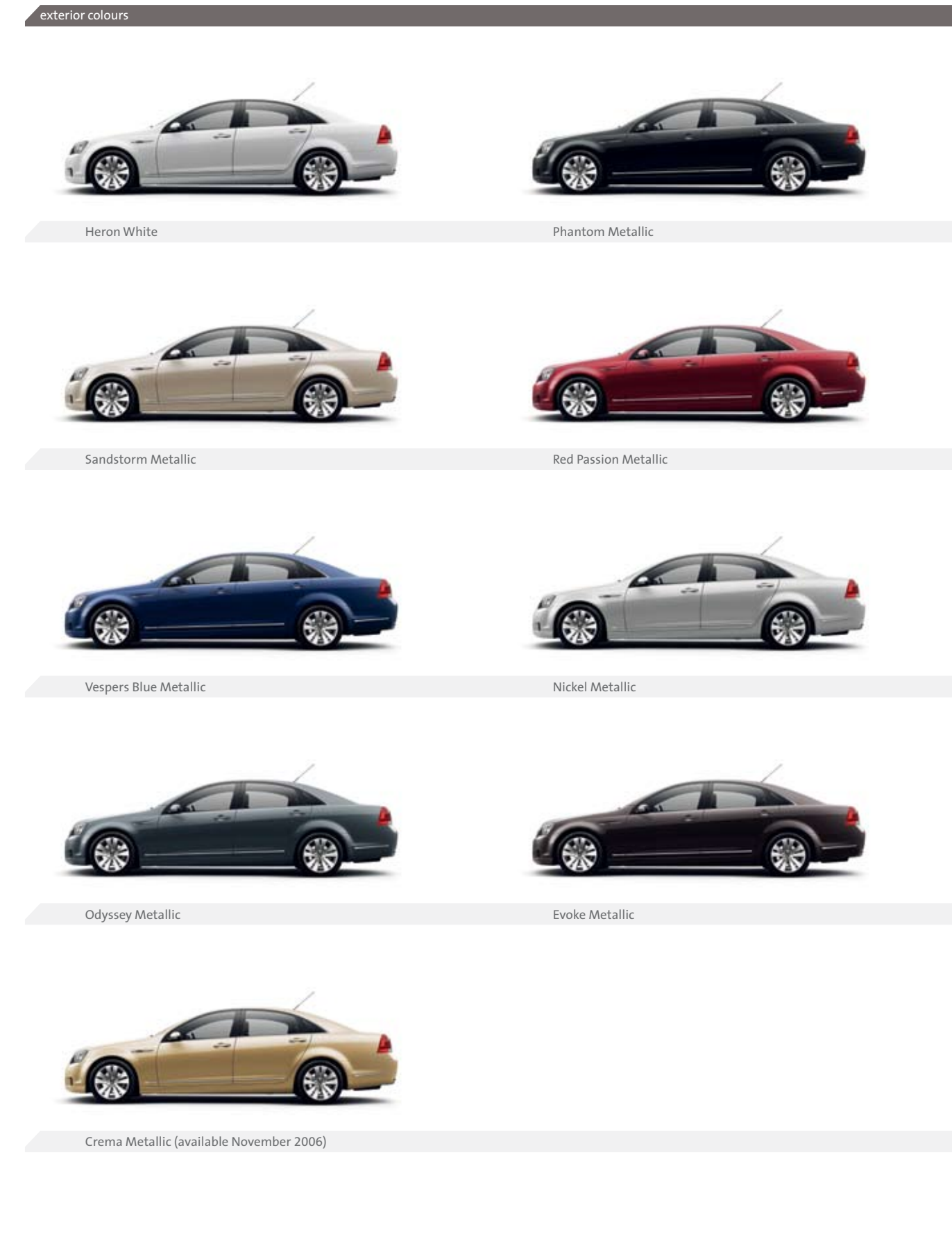



## easy purchase options

## Finance

SmartChoices, provided by GMAC Financial Services, is an array of automotive finance products designed to help the dream of driving a new Holden become a reality. Just select the product, term and payment structure that best suits your lifestyle and your Holden Dealer can provide more information.

## Insurance

Holden Insurance offers a range of competitively priced insurance products, providing tailor-made protection, at whatever level of cover you need. For more information, call the Holden Insurance hotline on 1300 784 026.

## Holden Leasing

Businesses of all sizes are now accessing vehicle leasing options with Holden Leasing. We operate nationally through the Holden Dealer Network and our dedicated service and support team. Our people are responsive professionals who understand your business and what it means to deliver total fleet management solutions. To find out how Holden Leasing can help you, call us on (03) 9693 0400.

## Holden MasterCard

Holden MasterCard can assist you to get into a new Holden sooner. 10% of credit purchases on this card goes towards a Rebate of up to \$3,000 on your new Holden<sup>1</sup>. That's a \$1 saving towards a new Holden for every \$10 spent. There are a range of extra features including up to 45 days interest free<sup>2</sup> on credit purchases and a competitive interest rate. Apply<sup>3</sup> online at [www.holden.com.au/mastercard](http://www.holden.com.au/mastercard) or call Holden MasterCard's 24 hour help line 131 200.

## ownership benefits

## Holden Service

With over 300 Holden Dealers, Holden can supply an enviable level of customer care. Our Service Network is one of the largest in the country. Only Holden Dealership technicians have access to regular Holden factory training and equipment.

## The Holden Luxury Edge

One of the extras you get from owning a new Caprice is extra peace of mind. With the Holden Luxury Edge, the first three handbook services are at no extra charge<sup>4</sup> as long as they fall within the first 12 months from date of first registration. For complete terms and conditions, just ask your Dealer.

## Holden New Vehicle Warranty

Every new Holden comes with a New Vehicle Warranty, covering your Holden for 3 years<sup>5</sup> or 100,000 kilometres, whichever comes first. This factory backed warranty covers items including the engine, transmission, interior and exterior components. Refer to your Owner's handbook or see your Holden Dealer for full terms, conditions and exclusions.

## Holden PLUS Extended Factory Warranty

Holden also offers Holden PLUS Extended Factory Warranty. Holden PLUS is a complete extension of your New Vehicle Warranty, giving you peace of mind because your car is factory backed for up to 3 additional years. The very same items covered under the New Vehicle Warranty will continue to be covered under Holden PLUS, without exclusion. Simply select a 1, 2 or 3 year Holden PLUS Extended Factory Warranty at the time you purchase your new Holden. See your Holden Dealer or call 1300 308 062 for full terms and conditions.

## 24 Hour Roadside Assistance

Provided for the first 3 years of your new Holden's life<sup>6</sup>. Holden Roadside Assistance is one of Australia's most comprehensive assistance packages with over 3000 Roadside Assistance patrols nationwide<sup>6</sup>. There to help with even the smallest service, the toll-free Roadside Assistance hotline is always open, 1800 817 100.

## Holden Ultra Roadside Assistance

Ultra Roadside Assistance provides additional benefits, over and above those supplied by our standard Roadside Assistance program. In certain circumstances it covers accommodation, alternative transport, rental car, accident assistance, Australia-wide vehicle recovery and more<sup>7</sup>. For more information call 1800 645 668.

## For more information contact

Holden Customer Assistance on 1800 033 349 Monday to Friday  
8am to 7pm or Saturday 9am to 1pm EST or visit  
[www.holden.com.au](http://www.holden.com.au)

<sup>1</sup> A total of \$3000 in the form of Holden Card 'Core Rebate' (plus additional 'Bonus Rebate' accumulated via the Partner Program) accrued over a maximum of five years may be applied per eligible vehicle purchased. Vehicle sales for which a fleet allowance is paid are not eligible for Holden MasterCard Rebate. Earning and redemption of Rebate towards a new Holden is subject to the Holden Card Rebate Program Rules. <sup>2</sup> The interest-free period applies where the card account is fully paid by the due date each month. <sup>3</sup> Applications are subject to Westpac's normal lending criteria. <sup>4</sup> Services include all labour and parts (except oil) as per the owner's handbook and exclude non-scheduled service work or repairs. Services must be conducted by an authorised Holden Dealer. <sup>5</sup> From date of first registration. <sup>6</sup> In remote or sparsely populated areas you may experience delay in obtaining Roadside Assistance. Refer to the Roadside Assistance brochure in your glovebox for full terms and conditions of this service. <sup>7</sup> See the Roadside Assistance brochure in your glovebox for full terms and conditions of this service.