

Holden Statesman



go in luxury



An icon, re-imagined

Your every need anticipated. Your every moment behind the wheel rewarded. Your every journey, an experience to savour.

This is the new Holden Statesman.

Six years in the making, it has been designed from the ground up around the most advanced suspension system ever developed for a Holden vehicle. Built to the most exacting tolerances in the company's history. Tested and refined – through computer modeling, prototyping and real world driving – more than any Holden before it.

Offering performance beyond all expectations, the new Statesman ushers in a new era of automotive refinement for drivers who accept nothing less than the absolute best.

It is an icon, re-imagined. A vehicle of renown, boldly re-interpreted. Sophisticated motoring, driven to perfection through world-class automotive engineering and design.

Wherever your destination. Whatever route you have planned. When you drive the new Holden Statesman, you go in luxury – all the way.



Deeply individual

Refinement comes in many forms, but few as perfectly proportioned as the new Holden Statesman.

With its exquisite fastback roof line, sloping stance and short front overhang, Statesman combines the poise of a classic luxury saloon with the style of a traditional grand tourer. All re-interpreted into an elegant, and deeply individual, contemporary form.

There is delight in the detail, too. Powerful projector headlamps illuminate the road far ahead, while mirror mounted 'puddle' lamps illuminate your path as you approach the vehicle.

The 17 inch alloy wheels, dramatic arches and dual exhaust hint at the power within. Fender vent indicators blend style with safety. Windshield wipers activate automatically when it rains and self-adjust based on how heavily it's falling. Moulded unobtrusively into the sculpted roof, even the streamlined radio antenna is a thing of beauty.

From the big picture to the smallest detail, nothing is overlooked nor left to chance. Including the opportunity to go one better by individualising your vehicle with Genuine Holden Accessories.



World-class luxury, the Australian way

The true beauty of the new Statesman lies not just in its sculpted body and ground breaking dynamics, but also its single-mindedness.

Australian from the word go, it was purpose engineered for this country's unique range of driving and climatic conditions. Then tested from one end of Australia to the other, and one extreme to the next.

Refined, and refined again until perfect – every element of the new Statesman unifies to ensure all encompassing automotive luxury for you and your passengers.

Which is why, for example, in addition to assured handling on freeways and country roads, city streets and gravel tracks, you are assured the new Statesman's electronic climate control will keep you cool in the fiercest Australian summer, and warm amidst the winter snow of Australia's alpine regions.

A local product of world-class research and development, delivering a truly outstanding driving experience. This is world-class luxury, the Australian way.



Astonishingly responsive and precise

The luxury myth suggests large equals unwieldy. The first corner you take in the new Statesman dispels it forever.

There's none of the vagueness you might expect from a vehicle of Statesman's size, none of the uncertain road feel, none of the body roll. Instead, the handling is astonishingly responsive and precise. The vehicle remains flat and stable while cornering. And you experience a direct, sports-car-like connection with the road at all times, on all surfaces.

The reason is Statesman's revolutionary new Linear Control Suspension with forward mounted steering rack and variable ratio steering. Teamed with the vehicle's advanced Electronic Stability Program, it gives Statesman the on-road agility of a car far more modest in dimension.

Even more remarkable, Statesman combines this sports-like handling with an exceptionally composed ride. From tight, twisting roads to highway cruising, optimum comfort and compliance are your constant driving companions.

The vehicle's braking is equally accomplished. The ventilated four-wheel disc brakes are large and powerful. The tyres, developed specifically to complement the Statesman's new suspension. In emergency braking situations, all combine with the vehicle's Anti-lock Braking System, Electronic Brake Assist and Electronic Brakeforce Distribution to help bring you to a stop with maximum control, in the shortest time and distance possible.



Sophisticated elegance

Inside, the new Statesman's intention to delight is obvious.

The workmanship throughout is of a standard usually reserved only for the flagship vehicles of Europe's most admired luxury marques. The wood grain accents and satin chrome controls. The sophisticated colour palette. The complementary textures and finishes. The soft 'theatre' lighting. All combine together to engender a modern air of tailored elegance.

Twin needle stitched, leather-trimmed seating embraces all occupants with the right balance of upholstered comfort and support. Head, leg and elbow room is generous, even with five adults on board.

In the front, 8-way electric seats put driver and passenger in their respective comfort zones at the touch of a button. As does the dual zone climate control. Arm rests are large and perfectly positioned. Front door storage expands to accommodate large objects and even holds a 600ml water bottle upright.

Thoughtful touches also abound for rear passengers, including slide out cup holders that remain hidden until required, and a fold down centre armrest that even houses a discreet storage unit.

If it's inner peace you crave, Statesman's whisper quiet ride will keep you alone with your thoughts. If not, the vehicle's 11 speaker, 230 watt, six disc CD sound system will accompany your travels with a soundtrack of exquisite spatial richness and clarity.

Everything you could ask for – with the added luxury of surprising affordability – this is the all-new Holden Statesman.



Focus, not excess

As exemplified by the new Statesman's elegantly streamlined instrument cluster and driver controls, intelligent automotive design is about focus, not excess.

To minimise distraction, all essential real-time vehicle data is presented clearly and concisely, directly in front of the driver, across four analogue instruments and three multifunction displays.

Controls for the most frequently used vehicle functions are located on the leather grip steering wheel. The intuitive thumbwheels and illuminated switches allow you not only to operate the sound system, trip computer and optional turn-by-turn satellite navigation* features, but also personalise the way each system's details are displayed. You can even receive phone calls hands-free on Bluetooth compatible mobile phones. All on the go, all without taking your hands from the wheel.

*Available late 2006

Secondary systems, such as the dual zone climate control and six disc CD player are located on the centre console. Clever use of satin chrome and tactile soft rubber ensures grip and immediate control identification. The high-resolution colour display ensures immediate communication of system settings and electronic parking assistance alerts.

Controls for the power windows and electric exterior mirrors are by your side, as is the ingeniously integrated handbrake. Map and interior lights are overhead.

Put simply, everything is within easy reach. As is your destination, when you have the luxury of driving the new Statesman.





Leather seats
Twin needle stitched, leather-trimmed
seats balance cushioning with support
for maximum driving comfort



LED tail lamps
Combining form with function,
the distinctive high illumination LED
tail lamps heighten vehicle visibility



Steering wheel controls
The new Statesman puts everything at your fingertips, including illuminated steering wheel controls for the audio system and trip computer



Gear selector
Switch from automatic to manual gearshifting at the flick of a wrist with Active Select



Centre console
In addition to playing both CDs and MP3 tracks, the 11 speaker, six disc sound system includes an auxiliary input jack for MP3 player connectivity



Speedo and fuel gauge
Satin chrome highlights add an aesthetic edge while providing a consistent visual cue to key instruments and controls

Textures

Suede and leather in subtle shades harmonise with wood grain accents to give the new Statesman an air of tailored elegance



Projector headlamps
Projector headlamps penetrate the night with concentrated and immensely powerful beams

Safety

The new Statesman's levels of luxury and refinement are surpassed only by its single-minded commitment to safety, with a multi-layered driver defence system that surrounds you – literally – with state-of-the-art active and passive safety technology. The former to help prevent collisions; the latter to help prevent injury in the event of a collision.

Active safety

Up to 200 times a second – that's how often the new Statesman's active safety systems monitor on-road dynamics. Everything from the vehicle's speed, lateral acceleration and rotation, to the steering wheel angle and brakeforce you apply.

When normal tolerances are exceeded, one or more of the following systems initiate integrated – non-intrusive – counter measures to help ensure you retain maximum control of the vehicle.

Co-ordination of active safety features Be it from the Electronic Stability Program (ESP®) for turning and cornering. The Traction Control System (TCS) that minimises slip when accelerating. Or the Anti-lock Braking System (ABS) with Electronic Brake Assistance (EBA) and Electronic Brakeforce Distribution (EBD) that helps you stop quickly with maximum control. You can expect 360° support from the new Statesman's integrated active safety systems.

ESP® Electronic Stability Program ESP® constantly compares the vehicle's movements with the steering wheel angle to determine if the vehicle is moving in the direction you intend. If skidding appears imminent, ESP® applies brake pressure to individual wheels as appropriate and, if necessary, trims engine power. This dramatically increases turning and cornering safety, especially in 'evasive action' situations.

TCS Traction Control System Designed to minimise slippage during acceleration, TCS recognises if either rear wheel has insufficient grip and adjusts drive force and brakeforce accordingly. It reduces wheelspin when accelerating on wet and icy roads, and also in 'split' conditions, such as when a vehicle has two wheels on bitumen and two on a gravel verge.

ABS Anti-lock Braking System If wheel 'lock up' is detected under forceful braking, ABS momentarily reduces brake pressure at the affected wheel. This improves braking efficiency – reducing stopping distances on most surfaces – and helps maintain steering control to ensure the vehicle remains directionally stable.

EBA Electronic Brake Assist In emergency braking situations, few drivers actually press the brake pedal firmly enough to achieve maximum braking performance. EBA is designed to sense how fast you press the brake pedal in an emergency, and maximise braking pressure to optimise braking performance.

EBD Electronic Brakeforce Distribution When a vehicle brakes, weight transfers to the front wheels. By regulating the brakeforce applied to each wheel, EBD ensures optimal balance between front and rear brakes, which helps minimise stopping distances.

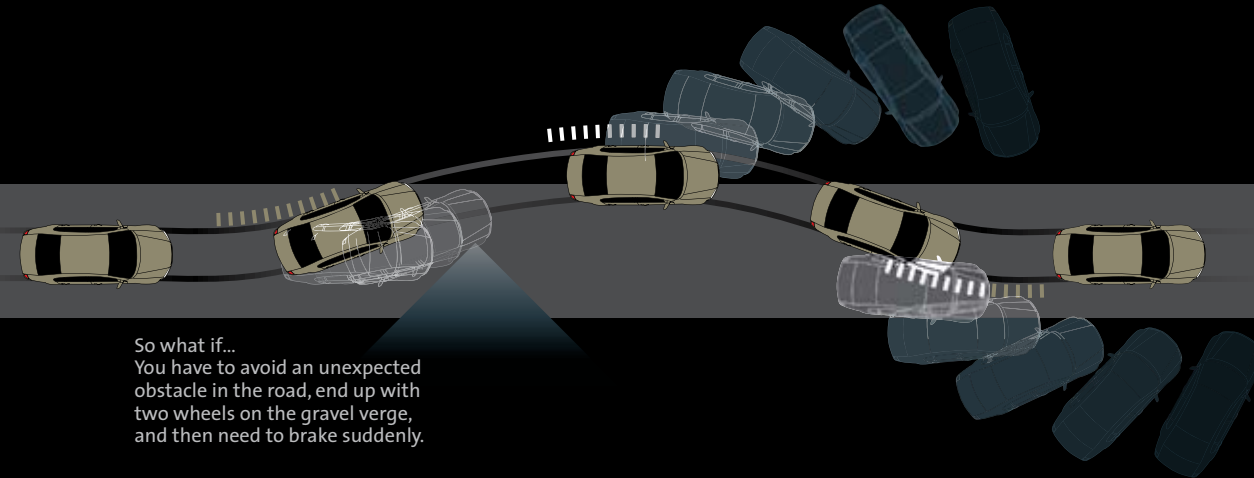
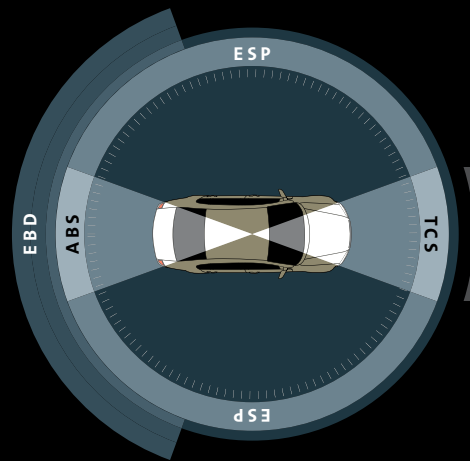

So what if... You have to avoid an unexpected obstacle in the road, end up with two wheels on the gravel verge, and then need to brake suddenly.

ESP® brakes the left rear wheel momentarily to avoid understeer.

TCS reduces torque to the left rear wheel to reduce slip.

ESP® brakes the right front wheel momentarily and reduces engine power to correct oversteer.

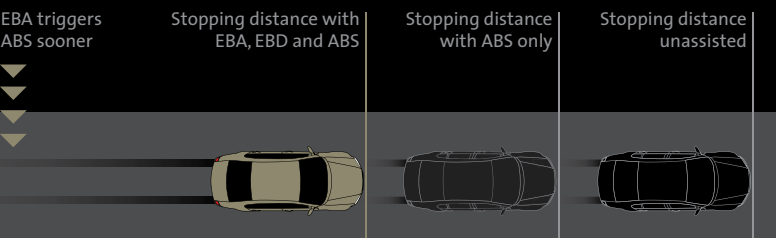

Sensing an emergency stop, EBA initiates maximum brakeforce, ABS maximises brake efficiency and EBD maintains optimal front/rear brake balance.

Passive safety

A collision is a contest between impact energy and your vehicle's safety features. You want everything possible on your side.

That's why the new Statesman features Holden's Adaptive Occupant Restraint System – which includes dual-stage front airbags for driver and front passenger – as well as multiple load paths to help channel impact energies and a safety cell reinforced with ultra high strength steel.

Most impressive of all, in a frontal crash, the new Statesman can automatically initiate and co-ordinate all on-board passive safety measures in an incredible 90 milliseconds (ms) – about the time it takes to snap your fingers.

Co-ordination of passive safety features To protect occupants from collision forces, Holden's Adaptive Occupant Restraint System uses forward and side sensors to detect the severity and direction of a collision, triggering the appropriate passive safety measures.

Safety cell, crumple zones and load paths In frontal and rear collisions, impact energy is absorbed by crumple zones and channelled away from the driver and occupants via multiple load paths.

The new Statesman's multiple load path strategy is also integral to side impact protection, as is the vehicle's safety cell. Strategically reinforced with steel seven times stronger than normal, it offers significantly increased protection against passenger safety cell intrusion across all vehicle sides.

- crash sensors
- 1 driver's front airbag
- 2 passenger's front airbag
- 3 side impact airbags
- 4 curtain airbags
- 5 front crumple zone
- 6 passenger safety cell
- 7 rear crumple zone



Pyrotechnic seatbelt pretensioners When an impact of sufficient severity is detected, small explosive charges force the front seatbelt buckles towards the cabin floor. This tightens the seatbelts and holds both driver and front passenger firmly against their seats.

Dual-stage front airbags For maximum protection in certain frontal collisions, the front airbags for driver and front passenger inflate in two stages, according to the impact severity and their respective seat positions.

The 60 litre driver airbag can fully inflate in 45 milliseconds. The front passenger airbag, which is oversized, can inflate to a full 125 litres in just 55 milliseconds.

Curtain and side impact airbags Side curtain airbags provide head and upper body protection for front passengers and left and right rear passengers in certain side-on collisions. Side impact airbags provide additional chest and thorax protection for the driver and front passenger.

Load limiters Following airbag deployment, load limiters unspool the front seatbelts incrementally to minimise the risk of seatbelt related injury.

Steering and brake pedal safety In severe frontal impacts, the steering wheel can collapse bi-directionally and, to prevent leg injury, the brake pedal detaches.

Active front seat head restraints In rear collisions, active head restraints tilt forward, closing the distance between your head and your seat's headrest, thus reducing the risk of whiplash injury to the neck.

Emergency shutdown Following a collision where airbags or seatbelt pretensioners have deployed, on-board safety systems will turn off the engine and fuel pump, unlock the doors and turn the hazard and interior lights on, if battery power is available.

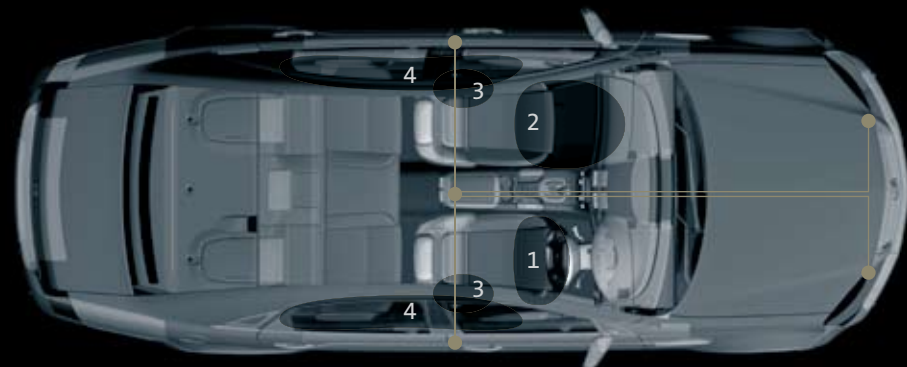

The new Statesman is a vehicle distinguished not only by its quality, but also the quality of thought evident in its many technological innovations. From the futuristic component synchronisation and optional on-board telematics, to the sublime convenience of integrated Bluetooth connectivity, it positively brims with ingenious ideas.

Holden Assist telematics*

Optional on the new Statesman, telematics enables vehicles to send and receive data – and have their position pinpointed at any time – via integrated GSM mobile phone network and global positioning satellite technology.

Owners of telematics-equipped vehicles can take advantage of Holden Assist, a subscription-based interactive security system that provides on-board assistance 24/7, based on one of three service levels:

Holden Assist Secure

- If stolen, Holden Assist can locate and track your vehicle, and working with police, safely immobilise the engine via remote technology.

Holden Assist Ultra

All Secure level features, plus:

- If an airbag is deployed, the system notifies an operator who will attempt to speak with the driver. If there is no response, emergency services are notified.
- If keys are locked in the vehicle, an operator can validate the owner's identity, then unlock the doors remotely.
- In an emergency, the driver can press the SOS button to speak with an operator, who will locate the vehicle and send emergency services if required.
- If roadside assistance is required, on the press of a button the vehicle is located and assistance despatched.
- If the vehicle battery is low, the system notifies an operator who will attempt to speak with the driver.

GM FleetView

Designed for businesses with on-the-road employees, fleet telematics are designed to increase driver and fleet manager productivity, while encouraging better driver behaviour and greater adherence to occupational health and safety practices. For full details on fleet telematics, call GM Fleet Customer Assistance on 1300 559 696.



Satellite navigation*

Turn-by-turn satellite navigation is optional on the new Statesman. Operated via the scroll wheel and buttons mounted on the steering wheel, the system provides visual directions via the centre driver display, full mapping via the colour LCD screen in the centre console, and audible directions via the vehicle's audio system.



Trip computer

The on-board trip computer is controlled via the scroll wheel and buttons mounted on the steering wheel. Trip data is shown on the electronic driver display. Depending upon your preferences, the information displayed can include:

- trip distance
- average speed
- average fuel usage
- distance to go
- time to go
- range
- odometer reading
- speed
- overspeed warnings (visual and audible)
- underverspeed warnings (visual and audible)
- rest reminders every two hours of driving time

It is even possible to track two trips simultaneously, for example a short day trip within a long interstate trip.

Personalisation

The new Statesman lets you tailor a range of vehicle functions to your individual liking, including:

- Departure lighting: when locking your vehicle remotely at night, the headlamps will remain on and turn off automatically after 30, 60, 90 or 180 seconds.
- Approach lighting: when unlocking your vehicle remotely at night, the headlamps can automatically come on for 60 seconds, or not at all.
- Multi-stage unlocking: when unlocking your vehicle remotely, you can have all four doors unlock at once, or the driver's door on the first press and the remaining doors on the second.

Priority flip key

The new Statesman comes with two priority keys, which store individual driver preferences, such as trip computer display options, climate control settings and radio station presets. Your preferred settings take effect the moment you unlock your car remotely.

Component synchronisation

To deter theft, the audio system, instrument cluster and other key components are electronically synchronised to the vehicle in which they were originally fitted. Unauthorised removal and re-use disables both the vehicle from which a component was taken, and the vehicle into which it is fitted.

Night panel

At night, interior lighting can be dimmed to leave only the speedometer illuminated. Should your attention be required, the relevant instrument lights up. This reduces driver distraction and fatigue, making it perfect for night driving in the country.

Front and Rear Park Assist

The electronic parking sensors on the new Statesman provide visual and audible aids when parking the vehicle. Appearing on the centre display, the visual display shows both the direction and distance of nearby objects.



Bluetooth

Integrated Bluetooth technology lets you take and make calls, hands-free, at the touch of a button with compatible Bluetooth mobile phones. The controls are conveniently mounted on your steering wheel, the microphone is housed in the roof console, and the call is heard over the audio system – which automatically mutes whatever is playing at the time. No wires. No cradles. No headsets.



MP3 player connectivity

The audio system includes an auxiliary input jack for external music sources, such as MP3 players.



DVD player

An integrated DVD player with fold down screen is available as an option. Designed for use by rear passengers, it is incorporated into the roof and comes complete with headphones and a remote control.

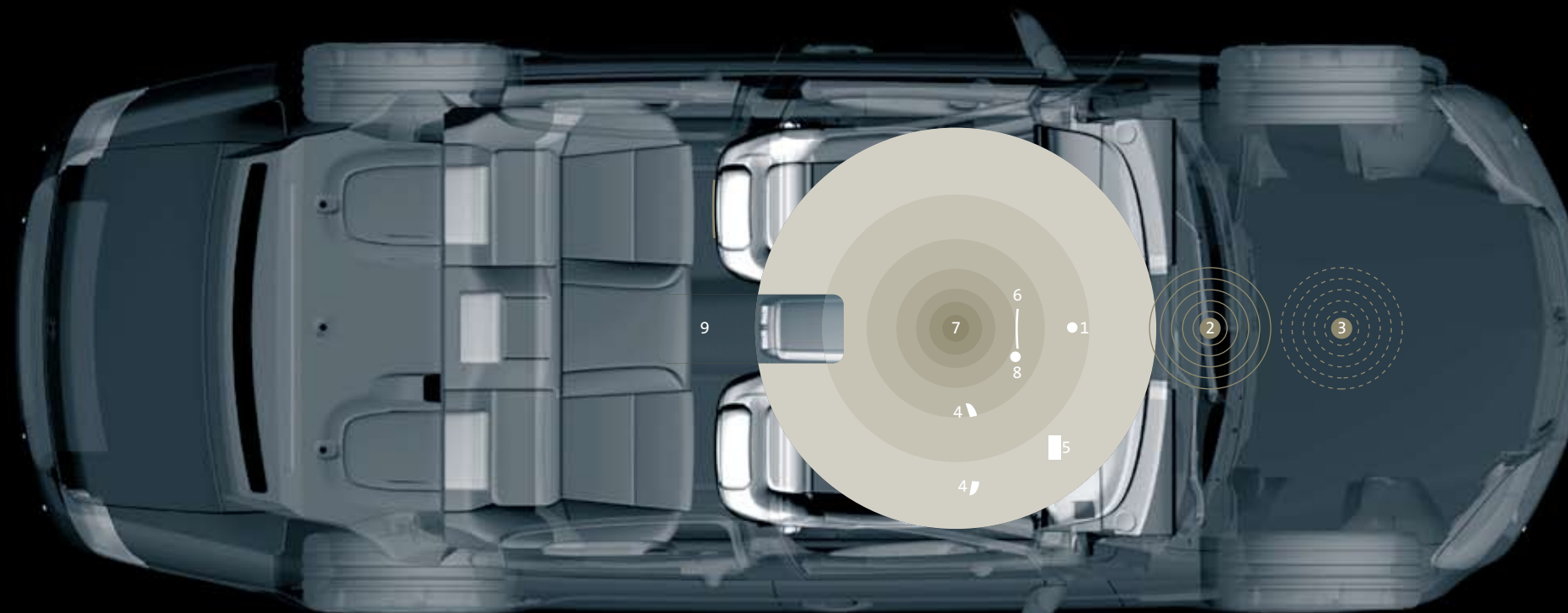

Location of features when fitted

- 1 Holden Assist SOS button located on rear vision mirror.
- 2 Telematics GSM network transmitter.
- 3 Satellite navigation GPS transmitter.
- 4 Steering wheel mounted scroll wheel and buttons for controlling satellite navigation, trip computer, audio system, personalising settings and hands-free phone calls using Bluetooth.
- 5 Centre driver display for messages such as satellite navigation directions, trip computer data and more.
- 6 Centre console screen displays full audio system data and full-colour mapping when satellite navigation is fitted.
- 7 Microphone for telematics communications and hands-free Bluetooth mobile phone calls.
- 8 Audio system auxiliary input jack for connecting MP3 players.
- 9 Integrated DVD player and screen.

Power

Power, with the luxury of choice. The new Statesman puts you in control with the option of two elite, high-performance engines – the 3.6 litre Alloytec High Output V6 with 5-speed automatic transmission, and the supremely responsive 6.0 litre Generation 4 Alloy V8 with 6-speed automatic transmission.

Alloytec V6

One of the most advanced production engines ever manufactured in Australia, the 3.6 litre Alloytec High Output V6 engine generates a potent 195kW at 6500rpm and 340Nm of torque at 2600rpm, with features that include:

- Alloy construction for power and strength
- Variable intake manifold for outstanding performance and reliability
- Double overhead camshaft for improved performance
- Four valves per cylinder to help the engine breathe better for greater performance
- Continuously variable valve timing for enhanced performance and responsiveness

5-speed automatic transmission with Active Select

Teamed with the Alloytec High Output V6 engine, the 5-speed automatic transmission with Active Select delivers smooth, crisp – almost seamless – gear changes. As well as the advantage of one-touch switching from automatic to manual shifting, for those times when you feel like true 'hands-on' driving.

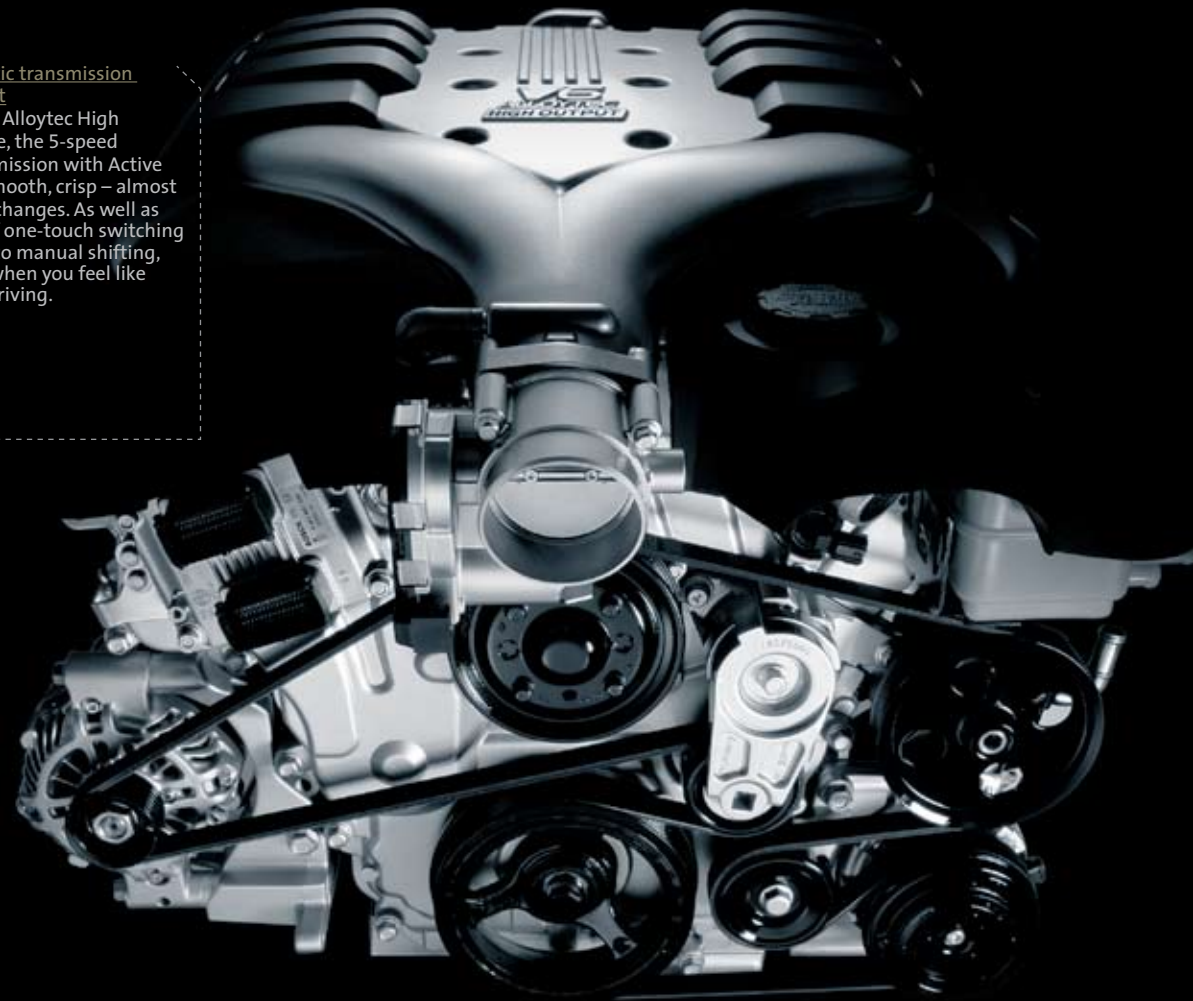

Generation 4 Alloy V8

For sheer road dominating power though, you literally cannot go past the 6.0 litre Generation 4 Alloy V8 engine. Delivering a brutal 270kW* of power and 530Nm* of torque, it features:

- Electronic Throttle Control for immediate response and maximum performance
- Lightweight alloy construction, enabling a more supple front suspension and smoother ride
- A one piece induction system for smooth airflow and superior breathing

6-speed automatic transmission with Active Select

Paired perfectly to the optional Generation 4 Alloy V8 engine, the 6-speed automatic transmission has a truly world-class shift feel, and delivers improved acceleration and fuel economy. Active Select gives you the added advantage of one touch switching between automatic or manual gear shifting.



Engine hardware may vary
* Figure quoted using 98 RON (PULP)

features

engine	exterior/interior	exterior/interior (continued)	safety/security
engine and transmission	wheels	driver (continued)	occupant safety
195kW, 3.6 litre High Output Alloytec V6 engine	17" x 7" alloy wheels. 225/55 R17 97V tyres	Service reminder. Appears 1,000km before service is due	Dual-stage front airbags for driver and front passenger
5-speed automatic transmission with Active Select (V6 only)	Full size alloy spare wheel	Tachometer	Side impact airbags for driver and front passenger
270kW*, 6.0 litre Generation 4 Alloy V8 engine		Sound system able to accommodate compatible mobile phone with phone kit fitted. Auto mute when phone is in use	Side curtain airbags
6-speed automatic transmission with Active Select (V8 only)	exterior	Bluetooth mobile phone connectivity	Front lap/sash seatbelts with load limiters and pyrotechnic pretensioners
Limited Slip Differential	Front fog lamps	Satellite navigation (available late 2006)	Front seatbelt sash height adjustable
	Projector headlamps		Rear seat child restraint anchor points (3)
control and handling	LED tail lamps	entertainment	Active front seat head restraints to help reduce risk of injury in a collision from behind
Linear Control Suspension	Exterior mirrors with 'puddle' lamps	Blaupunkt AM/FM stereo	
Electronic Stability Program (ESP®) incorporating:	Dual exhaust (V6 only)	6 disc CD player. MP3 compatible	security
Anti-lock Braking System (ABS)	Quad exhaust (V8 only)	11 speakers including sub-woofers. Total 230 watts	Remote control priority flip key:
Electronic Brakeforce Distribution (EBD)	Chrome body side mouldings	Speed dependent volume control	Operates central locking
Electronic Brake Assist (EBA)		Rear seat overhead DVD player	Operates interior lighting. Time delay on entry. Automatic illumination when engine turned off
Traction Control System (TCS)	driver	Diversity antenna: FM	Operates exterior lamps, to show location of car at night
	Steering wheel height and reach adjust		Enables/disables alarm system
	Leather wrap steering wheel	seating	Unlocks boot
	Leather wrap gear selector	Leather seat trim	Disables remote boot release button in glovebox (when locking)
	Multifunction steering wheel, featuring illuminated controls for:	8-way electric adjustment of front seats: Slide. Cushion tilt. Height. Recline	Horn sounds if front door is ajar when remote locking
	Sound system	Adjustable driver and front passenger seat lumbar support	Sound system operates only in original vehicle
	Trip computer		Holden Assist telematics (available late 2006)
	Bluetooth phone	cabin comfort	
	Satellite navigation (where fitted, available late 2006)	Dual zone electronic climate control	road safety
	Multifunction driver display, featuring:	6.5" multifunction colour LCD screen. Displays stereo and climate control information. DVD player and satellite navigation compatible (where fitted, available late 2006)	Emergency mode after seatbelt pretensioners are triggered.
	Trip computer information	Power windows. Driver and front passenger windows express up and down	On-board computer turns engine and fuel pump off. Unlocks doors. Turns hazard lights and interior lamp on (if battery power available)
	Sound system information	Electric tilt and slide sunroof	
	Priority flip key for 2 people. When unlocking car it automatically restores settings for:	Front centre sliding armrest with leather trim	● standard
	Climate control	Rear seat centre armrest with storage compartment	○ optional
	Radio presets	Vanity mirror, driver and front passenger. Illuminated, with cover	
	Trip computer	Sunglasses holder (except where sunroof fitted)	
	Speed warning	Chrome finish interior door handles	
	Headlamp and interior lighting time delay options	Passenger overhead assist handles; rear with coat hooks	
	Cruise control	Front and rear reading lamps	
	Front and Rear Park Assist	Door entry lamps	
	Power exterior mirrors		
	Rain sensing wipers	storage and cargo	
	Automatic headlamp mode. Switches on at twilight or low light. Manual override	Twin cup holders in front centre console and rear seat	
	Headlamps auto off feature (variable delay)	Centre console storage compartment	
	Trip computer with triple display, including:	Auxiliary power socket in console and boot	
	Average speed	Fold-down rear seat centre 'ski' hatch for long loads	
	Odometer/tripmeter	Luggage net (adjustable) in boot to keep small items in place	
	Distance/time to go		
	Instantaneous/average fuel consumption		
	Fuel used/range		
	Visual and audible speed warning		
	Tracks two trips simultaneously (eg. short day trip within long interstate trip)		
	Rest reminder warning after a nominated length of continuous driving (adjustable setting)		

* Figure quoted using 98 RON (PULP)

technical specifications

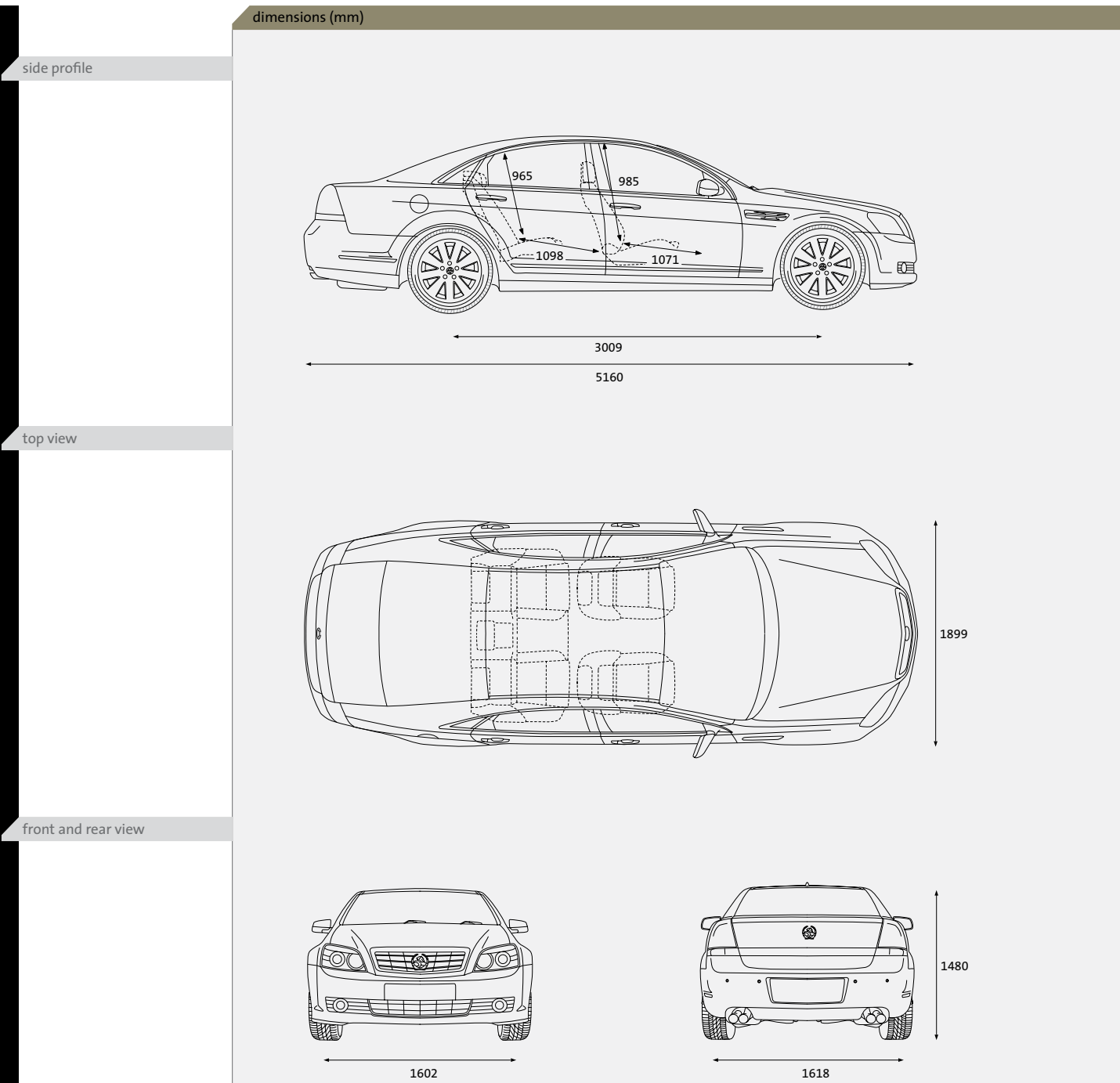

	195kW, 3.6 litre High Output Alloytec V6 engine	270kW,* 6.0 litre Generation 4 Alloy V8 engine		Statesman
Engine	3.6L 60-degree Double Overhead Cam V6 with 4 valves per cylinder. Twin knock control sensors with individual cylinder adaptive control. On-board diagnostics	6.0L 90-degree OHV V8. Cross flow cylinder heads. Twin knock control sensors. On-board diagnostics	Recommended petrol octane rating	91 RON ULP Note that using 95 RON (PULP) or higher may result in improved engine performance and economy
	Continuously variable camshaft phasing for inlet and exhaust cams. Variable Intake Manifold (VIM)	Central plenum with individual symmetrical runners	Petrol tank capacity (L)	73
	High energy distributorless ignition. Solid state, voltage-driven Direct Fire ignition, coil-on-plug with on-board igniter	High energy, distributorless ignition. Solid state Direct Fire ignition, coil near plug with integrated igniter	Brakes	Four wheel disc. Ventilated discs – front and rear. Twin piston alloy front caliper, single piston alloy rear caliper
Capacity (cc)	3564	5967	Electronic Stability Program (ESP®)	Incorporating: Anti-lock Braking System (ABS), Electronic Brakeforce Distribution (EBD), Electronic Brake Assist (EBA), Traction Control System (TCS)
Compression ratio (:1)	10.2	10.4	Suspension	Front: MacPherson strut. Direct acting stabiliser bar. Progressive rate coil springs Rear: Multi-Link Independent Rear Suspension (IRS) Semi-trailing arm. Progressive rate mini-block coil springs. Stabiliser bar
Power (ECE, kW)*	195kW @ 6500rpm	270kW* @ 5700rpm	Steering	Variable ratio rack and pinion
Torque (ECE, Nm)#	340Nm @ 2600rpm	530Nm* @ 4400rpm	Track (mm)	Front: 1602 Rear: 1618
Exhaust system – stainless steel	Dual exhaust	Quad exhaust	Turn circle (kerb to kerb, m)	11.6
Engine cooling	Electric Cooling Fans	Electric Cooling Fans	Wheelbase (mm)	3009
Gear ratios	5sp Auto	6sp Auto	Exterior design dimensions (mm)	Length Width (excluding mirrors) Height Ground clearance
1st	3.42	4.03		5160 1899 1480 110
2nd	2.21	2.36	Interior design dimensions (mm)	Leg Shoulder Head Hip
3rd	1.60	1.53		1071 1501 985 1439
4th	1.00	1.15	Front	1098 1500 965 1472
5th	0.75	0.85	Rear	
6th	–	0.67	Boot volume (L)	535
Final drive ratio	2.92	2.92	Towing (kg)	Maximum towing: 2100. Holden approved 1200, 1600 and 2100 towing equipment is available. See your Holden Dealer for details.
	#Maximum figures as per ECE regulations *Figure quoted using 98 RON (PULP)		Service	The first inspection is due at 3,000km or 3 months (whichever occurs first). The first service is due at 15,000km or 12 months (whichever occurs first). Thereafter, at every 15,000km or 12 months since the last service (whichever occurs first). Additional services are required under certain driving conditions, such as when towing (refer to owner's handbook). Maintenance-free long life, accessory drive belt with automatic tensioner. Dual belt on V8. Holden Dealer 'Tech 2' computerised analysis available for engine management system.

vehicle dimensions



trims and colours

Statesman

exterior colours										interior trim		
Heron White	Phantom	Sandstorm	Red Passion	Vespers Blue	Nickel	Odyssey	Evoke	Crema			Metro leather	
•	•	•	•	•	•	•	•	•			Light Urban leather	
leather trim												
 <p>Metro</p>						 <p>Light Urban</p>						

Variations between colours shown and actual paint colours/interior trim colours may occur due to the printing process. Actual vehicle colours may appear different under certain light conditions. Trim patterns are not to scale. Indicative only.

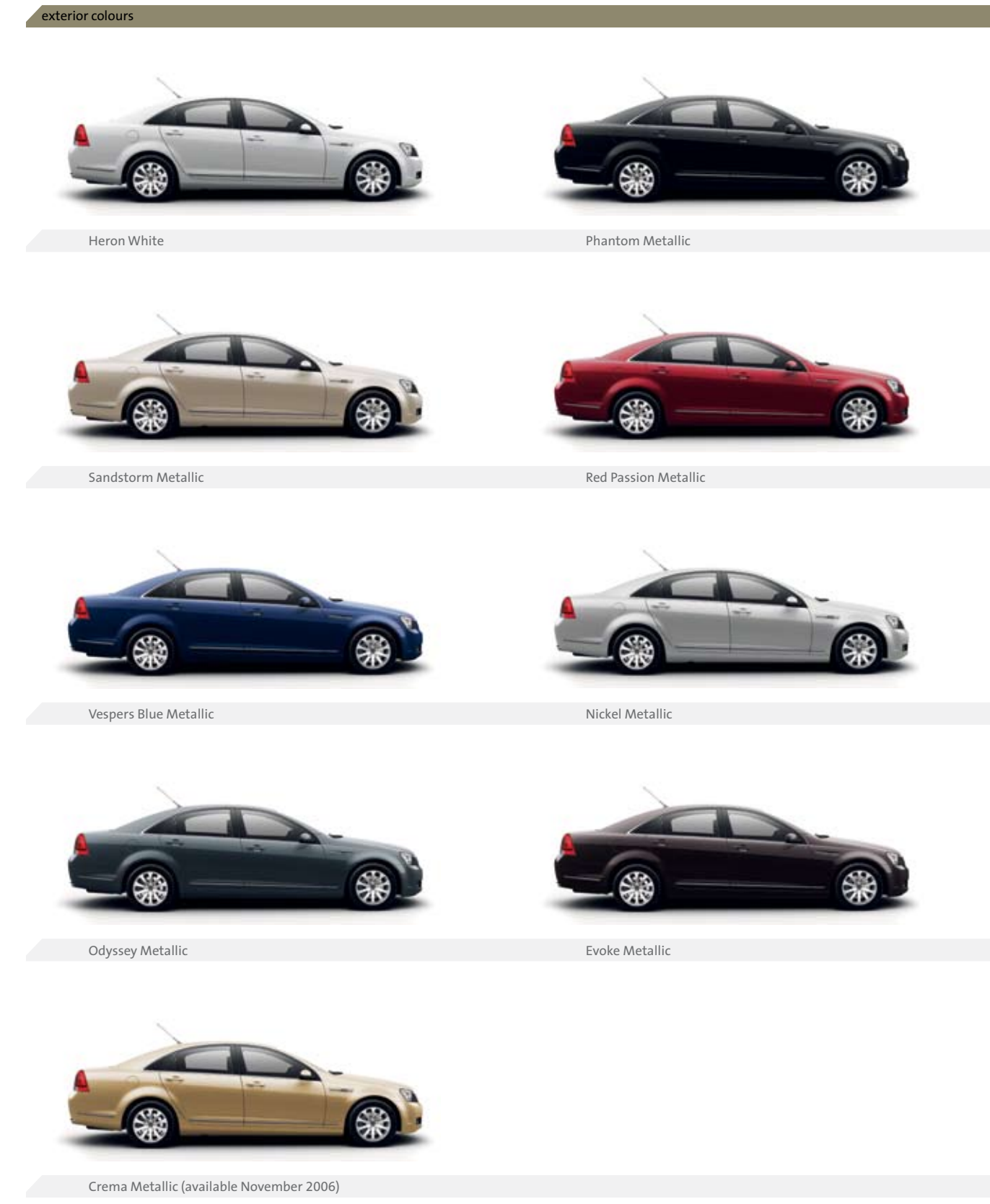

easy purchase options

Finance

SmartChoices, provided by GMAC Financial Services, is an array of automotive finance products designed to help the dream of driving a new Holden become a reality. Just select the product, term and payment structure that best suits your lifestyle and your Holden Dealer can provide more information.

Insurance

Holden Insurance offers a range of competitively priced insurance products, providing tailor-made protection, at whatever level of cover you need. For more information, call the Holden Insurance hotline on 1300 784 026.

Holden Leasing

Businesses of all sizes are now accessing vehicle leasing options with Holden Leasing. We operate nationally through the Holden Dealer Network and our dedicated service and support team. Our people are responsive professionals who understand your business and what it means to deliver total fleet management solutions. To find out how Holden Leasing can help you, call us on (03) 9693 0400.

Holden MasterCard

Holden MasterCard can assist you to get into a new Holden sooner. 10% of credit purchases on this card goes towards a Rebate of up to \$3,000 on your new Holden¹. That's a \$1 saving towards a new Holden for every \$10 spent. There are a range of extra features including up to 45 days interest free² on credit purchases and a competitive interest rate. Apply³ online at www.holden.com.au/mastercard or call Holden MasterCard's 24 hour help line 131 200.

ownership benefits

Holden Service

With over 300 Holden Dealers, Holden can supply an enviable level of customer care. Our Service Network is one of the largest in the country. Only Holden Dealership technicians have access to regular Holden factory training and equipment.

The Holden Luxury Edge

One of the extras you get from owning a new Statesman is extra peace of mind. With the Holden Luxury Edge, the first three handbook services are at no extra charge⁴ as long as they fall within the first 12 months from date of first registration. For complete terms and conditions, just ask your Dealer.

Holden New Vehicle Warranty

Every new Holden comes with a New Vehicle Warranty, covering your Holden for 3 years⁵ or 100,000 kilometres, whichever comes first. This factory backed warranty covers items including the engine, transmission, interior and exterior components. Refer to your Owner's handbook or see your Holden Dealer for full terms, conditions and exclusions.

Holden PLUS Extended Factory Warranty

Holden also offers Holden PLUS Extended Factory Warranty. Holden PLUS is a complete extension of your New Vehicle Warranty, giving you peace of mind because your car is factory backed for up to 3 additional years. The very same items covered under the New Vehicle Warranty will continue to be covered under Holden PLUS, without exclusion. Simply select a 1, 2 or 3 year Holden PLUS Extended Factory Warranty at the time you purchase your new Holden. See your Holden Dealer or call 1300 308 062 for full terms and conditions.

24 Hour Roadside Assistance

Provided for the first 3 years of your new Holden's life⁶. Holden Roadside Assistance is one of Australia's most comprehensive assistance packages with over 3000 Roadside Assistance patrols nationwide⁶. There to help with even the smallest service, the toll-free Roadside Assistance hotline is always open, 1800 817 100.

Holden Ultra Roadside Assistance

Ultra Roadside Assistance provides additional benefits, over and above those supplied by our standard Roadside Assistance program. In certain circumstances it covers accommodation, alternative transport, rental car, accident assistance, Australia-wide vehicle recovery and more⁷. For more information call 1800 645 668.

For more information contact

Holden Customer Assistance on 1800 033 349 Monday to Friday 8am to 7pm or Saturday 9am to 1pm EST or visit www.holden.com.au

¹ A total of \$3000 in the form of Holden Card 'Core Rebate' (plus additional 'Bonus Rebate' accumulated via the Partner Program) accrued over a maximum of five years may be applied per eligible vehicle purchased. Vehicle sales for which a fleet allowance is paid are not eligible for Holden MasterCard Rebate. Earning and redemption of Rebate towards a new Holden is subject to the Holden Card Rebate Program Rules. ² The interest-free period applies where the card account is fully paid by the due date each month. ³ Applications are subject to Westpac's normal lending criteria. ⁴ Services include all labour and parts (except oil) as per the owner's handbook and exclude non-scheduled service work or repairs. Services must be conducted by an authorised Holden Dealer. ⁵ From date of first registration. ⁶ In remote or sparsely populated areas you may experience delay in obtaining Roadside Assistance. Refer to the Roadside Assistance brochure in your glovebox for full terms and conditions of this service. ⁷ See the Roadside Assistance brochure in your glovebox for full terms and conditions of this service.

A word about this catalogue. We have tried to make this catalogue as comprehensive and factual as possible. However, since the time of printing some of the information you'll find here may have been updated. Also, some of the equipment shown or described through this catalogue may have been changed and / or is available at extra cost. Further, GM Holden Ltd, reserves the right to make changes at any time without notice, in prices, colours, materials, equipment and models. Your Holden Dealer has details, and before ordering, you should ask them to bring you up to date. No Holden Dealer or other person is authorised or permitted to give or make any statement, assertion or undertaking in relation to the quality, performance characteristics, descriptions or fitness for any purpose of any Holden product which is at variance with any written statement, assertion or undertaking on any of these subjects given or made by GM Holden Ltd ABN 84 006 893 232 in its published sales literature, and GM Holden Ltd does not accept any liability for any such unauthorised action. GM Holden Ltd has authorised dealers in many parts of Australia for the sale of service parts and the provision of service to owners of Holden's products. Every endeavour is made to ensure that such dealers carry adequate stocks of service parts, but GM Holden Ltd doesn't make any promise other than that contained in the New Vehicle Warranty given by GM Holden Ltd that such parts or service facilities will be available at any specific location or at any particular time. Express warranties offered for Holden products are subject to the conditions set out in all vehicle handbooks. Details also available from GM Holden Ltd on request. Copyright GM Holden Ltd. July 2006. emerystudio STAWM0106 AD12066