



medium-heavy duty

IH
INTERNATIONAL TRUCKS

PERFORMANCE TO SATISFY YOUR NEED

Good truck performance has many aspects, takes many forms. Ample engine power, rugged construction, economy of operation, comfort, safety.

These are the ingredients of INTERNATIONAL truck performance. They put real value into the new C-line medium/heavy duty models. Value for you.

In this range there are ten basic models to choose from including a four wheel drive unit. All are available with optional wheelbases — one to suit you.

Both petrol and diesel power units are available in this range. They are individually work matched to the truck's capacities and incorporate the latest in metallurgy and engineering

know-how. Consequently they give you ample power matched with economy. And they last.

All these trucks have strong frames and rugged suspensions. They're engineered to withstand the toughest work, yet with no sacrifice in riding comfort.

INTERNATIONAL TRUCKS not only give you profitable operation; the added bonus is safe operation. Big brakes all round give powerful and fade-free stopping. Low pedal effort is yours with air assistance on the CD-1840 and vacuum power assistance on all other models.

Safety extends into the cab interiors to give you comfortable fatigue free driving — all day long. Deep padded adjustable seats provide firm support, controls fall within easy reach. Clearly calibrated, full instrumentation gives fast knowledge of truck's performance and big glass areas provide exceptional all round vision.

For the performance you want, INTERNATIONAL TRUCKS can serve you best.

C-1600

GVW 19,500 lbs.
GCW 32,000 lbs.

This chassis pays handsome dividends in tray and container applications as well as other uses. It is powered by a strong engine — the INTERNATIONAL 6-281 petrol six cylinder. Power and torque figures of 142 BHP at 3,800 RPM and 241 lb. ft. at 1,800 RPM make light work of heavy loads, speed cartage and so lower costs. If your preference is for diesel power, its attendant economies can be yours with the six cylinder Perkins 6.354. This engine's output has been up-rated with the introduction of the C-line and gives this truck greater workability than previously available.

Power is transmitted through a four speed synchromesh gearbox to a hypoid rear axle. Thence to the rear wheels through fully floating shafts — induction hardened for great resistance to shock loads.

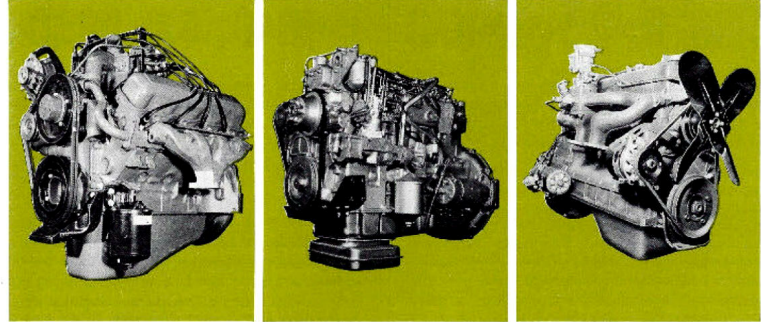

The dynamic INTERNATIONAL V-345 is fitted to the C-1840 and is optional for the C-1820. Its output of 177 BHP at 4,000 RPM and gross torque of 302 lb. ft. at 2,000 RPM ensures you have more than adequate power to meet every road condition.

The Perkins 6.354 provides optional diesel power for the C-1600, C-1640 and C-1820. Producing 120 maximum BHP at 2,800 RPM and 260 lb. ft. torque at 1,450 RPM this engine gives powerful yet economical operation for all conditions.

Standard for the C-1640 and C-1820 is the INTERNATIONAL 6-282 petrol engine. Low stressed design ensures minimum maintenance. It develops 148 BHP at 3,800 RPM and maximum torque of 244 lb. ft. at 1,800 RPM.

CD-1840

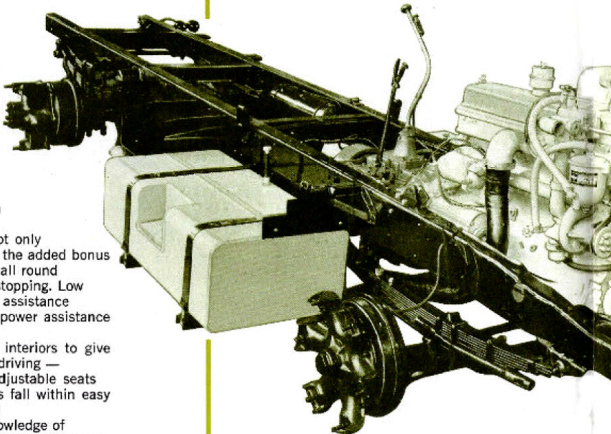

SPECIFICATIONS: C-LINE MEDIUM-HEAVY DUTY

Model	C-1600	C-1600 4 x 4	C-1640	C-1820	C-1840	CD-1840
Engines Standard Optional	6-281 petrol 6.354 diesel	6-281 petrol	6-282 petrol 6.354 diesel	6-282 petrol V-345 petrol 6.354 diesel	V-345 petrol	CAU-160B Diesel
W.B.	153, 171, 189 in.	153, 171 in.	153, 171, 189 in.	153, 171, 189 in.	153, 171 in.	153, 171 in.
GVW Optional	19,500 *16,000	20,000	22,500 *21,500 *21,000 *20,500	25,000 *23,500	25,500	25,500
GCW Optional	32,000 *30,000	30,000	38,500	43,500 146,000	51,000	53,000

* With optional tyre sizes

† With V-345 or 6.354 engines

PERFORMANCE TO SATISFY YOUR NEED

Good truck performance has many aspects, takes many forms. Ample engine power, rugged construction, economy of operation, comfort, safety. These are the ingredients of INTERNATIONAL truck performance. They put real value into the new C-line medium/heavy-duty models. Value for you. In this range there are ten basic models to choose from including a four wheel drive unit. All are available with optional wheelbases — one to suit you. Both petrol and diesel power units are available in this range. They are individually work matched to the truck's capacities and incorporate the latest in metallurgy and engineering know-how. Consequently they give you ample power matched with economy. And they last. All these trucks have strong frames and rugged suspensions. They're engineered to withstand the toughest work, yet with no sacrifice in riding comfort. INTERNATIONAL TRUCKS not only give you profitable operation; the added bonus is safe operation. Big brakes all round give powerful and fade-free stopping. Low pedal effort is yours with air assistance on the CD-1840 and vacuum power assistance on all other models. Safety extends into the cab interiors to give you comfortable fatigue free driving — all day long. Deep padded adjustable seats provide firm support, controls fall within easy reach. Clearly calibrated, full instrumentation gives fast knowledge of truck's performance and big glass areas provide exceptional all round vision. For the performance you want, INTERNATIONAL TRUCKS can serve you best.

C-1600

GVW 15,500 lbs.
GCW 32,000 lbs.

This chassis pays handsome dividends in tray and container applications as well as other uses. It is powered by a strong engine — the INTERNATIONAL 6281 petrol six cylinder. Power and torque figures of 142 BHP at 3,800 RPM and 241 lb. ft. at 1,800 RPM make light work of heavy loads, speed cartage and so lower costs. If your preference is for diesel power, its attendant economies can be yours with the six cylinder Perkins 6354. This engine's output has been up-rated with the introduction of the C-line and gives this truck greater workability than previously available. Power is transmitted through a four speed synchromesh gearbox to a hypoid rear axle. Thence to the rear wheels through fully floating shafts — induction hardened for great resistance to shock loads.

C-1600 4X4

GVW 20,000 lbs.
GCW 38,000 lbs.

Rough or muddy ground conditions, seemingly impossible gradients — they're light work with the added traction and high ground clearance you get with this four wheel drive unit. And you have the power to match this agility with the INTERNATIONAL 6281 six-cylinder petrol engine.

In combination with the four speed synchromesh gearbox is a two speed transfer case. The resulting eight forward transmission ratios in four wheel drive help you to get further, get more work done.

And every component of this truck is built to take it — built to give unfailing service under arduous conditions.

C-1640

GVW 22,500 lbs.
GCW 38,500 lbs.

Having heavy duty features such as sodium cooled exhaust valves and two piece exhaust manifold, the INTERNATIONAL 6282 petrol engine provides you with increased power to easily handle the bigger payload of the C-1640.

Ranging in application from tray, tipper, container to many other uses, this versatile unit has been engineered for strength in every component to give you profitable service. As optional diesel power you are offered the six-cylinder Perkins 6354. Diesel economy and robust construction give low running costs over long periods. Both engines are true truck engines designed to easily withstand the rigours of truck operation. A spiral bevel two speed electric shift rear axle is fitted, enabling split changes and consequent saving in time on long hauls.

C-1820

GVW 25,000 lbs.
GCW up to 46,000 lbs.

You are offered a choice of three engines with this model, an ideal chassis for prime mover applications as well as tipper and other uses. Standard power unit is the new INTERNATIONAL 6282 petrol engine.

If your preference is for V8 power, the INTERNATIONAL V-345 petrol engine is available. It combines high power output with excellent low speed torque to easily handle heavy loads.

Diesel power is also available with the Perkins 6354 — designed for durability and economy as well as having the power to match this truck's capacity. To speed haulage a sturdy five speed close ratio gearbox transmits power to a two speed electric shift rear axle.

C-1840

GVW 25,500 lbs.
GCW 51,000 lbs.

Offering you heavy duty hauling capability this chassis is eminently suitable for prime mover applications. It is powered by the INTERNATIONAL V-345, a V8 with the strength to match this truck's great capacity. Its low stressed design ensures years of trouble free service. Features including unique piston design for maximum power combustion, roto coil exhaust valves and water jacketed intake manifold are designed to give this engine its outstanding performance characteristics. Chassis rails are high torsional strength steel channel with L-shaped outer reinforcement. Heavy duty suspension components easily carry rated loads; make rough roads feel smooth.

CD-1840

Top of the C line. This unobstructed view shows you its heavily reinforced frame and rugged components — the thoroughness of design that gives this truck great favour among long haul operators.

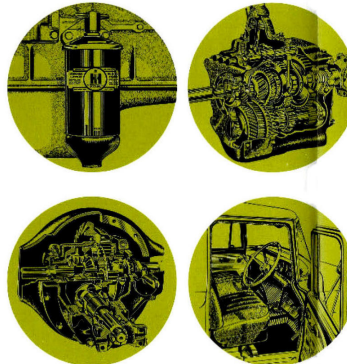
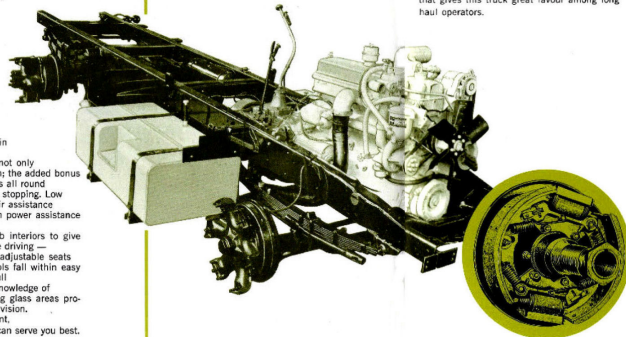

BRAKES — Powerful braking is assured with well designed power assisted units incorporating generous lining areas.

2 SPEED AXLE — Fitted to all models except the C-1600 and C-1600 4 x 4 is a two speed rear axle, enabling 'split changes' making higher average speeds possible.

3 SPEED TRANSMISSION — Standard transmission on the C-1800, C-1840 and CD-1840 are rugged five speed gearboxes which all employ large gear surfaces and big bearings to ensure smooth power delivery and long life.

OIL FILTER — A full flow oil filter is fitted to all engines ensuring that no damaging particles reach bearing surfaces, benefiting you with increased engine life.

CAB — Designed for the driver's comfort and safety these all steel cabs feature new deeply padded, fully adjustable seats with hard wearing surfaces for long life. A relaxed driving position is assured with controls that fall readily to hand and easily read instrument calibration. Two speed windshield wipers are fitted to give you unobstructed vision in adverse weather conditions and optional equipment includes cab heater/demister for your driving comfort in cold weather.

CD-1840

GVW 25,500 lbs.
GCW 53,000 lbs.

Capable of hauling the greatest capacity of this range is this diesel powered chassis excelling in prime mover applications. The beefy Cummins CAU-160B diesel engine supplies you with the muscle for this unit, having adequate power in reserve for hilly conditions. With a gross output of 160 BHP at 2,650 RPM and maximum torque of 345 lb. ft. at 1,700 RPM this engine pulls hard throughout its entire speed range. Sensibly placed gear ratios through the five speed transmission and two speed rear axle ensure you with a smooth power flow. Twin 60 gallon step tanks are fitted for long distance work. Bold and rugged construction throughout make this chassis ideal for profitable heavy hauling.



INTERNATIONAL HARVESTER COMPANY OF AUST. PTY. LTD.

In order that product improvements may be introduced at any time, specifications are subject to change without notice. Illustrations may include optional equipment. Colours of trucks are not necessarily standard.



A-151-T 10.6M-9 PRINTED IN AUSTRALIA

