



Mercedes-Benz

The Actros

Authorised Dealer

To speak to your nearest authorised Mercedes-Benz Dealer call **1300 66 22 30**.

For full Warranty details and limitations contact your authorised Mercedes-Benz Dealer. Specifications and information referred to herein is correct at the time of publication. Some of the equipment depicted either on vehicle illustrations or separately may be non-standard or optional at extra cost.

Mercedes-Benz Australia/Pacific Pty Ltd reserves the right to discontinue or modify any vehicle or optional equipment at any time without prior notice to meet any requirement of a manufacturing or commercial nature which it may deem appropriate. Consult your authorised Mercedes-Benz Dealer for the latest details on specifications, options, prices and availability. www.mercedes-benz.com.au

Telligent® is a registered trademark of Daimler AG. *2008 Build only.

LMCT 6776

Mercedes-Benz Australia/Pacific Pty Ltd, ABN 23 004 411 410. 44 Lexia Place, (PO Box 4214) Mulgrave, Victoria 3170 Telephone: (03) 9566 9317 Facsimile: (03) 9562 0397

The  and the words Mercedes-Benz are registered trademarks of Daimler AG, Germany. Printed in Australia. TF DCBRO605 04/08



Designed with the driver in mind.

The Actros is the economical solution for today's stringent emission laws. BlueTec® is the SCR diesel technology for heavy and medium duty commercial vehicles from Mercedes-Benz. With this technology, a catalytic converter is responsible for reducing nitrogen oxide emissions. This is done with the aid of an additive called AdBlue, which is fed from a separate tank. AdBlue is an aqueous, non-toxic solution that helps to convert nitrogen oxides into harmless substances. BlueTec® has the added advantage of working extremely economically.



Ergonomics and comfort in the workplace

Everything a driver wants and more.

When it comes to designing a truck, we look to the people who know them inside and out – the drivers. The result is a tougher, bigger and all around better Actros offering one of the best combinations of features and options in its class. High performance V6 and V8 engines for extra power and torque. Cabin designs offering unsurpassed comfort, convenience

and stowage space. A unique twin-bellows rear suspension system and refined aerodynamics for improved driving dynamics. Add state-of-the art Telligent® engine, shifting and braking electronics plus a host of advanced safety features and you have a truck that is truly designed with the driver in mind.



The driver's cab: the workplace, operating convenience

Spacious cabs.

L-cabs feature a standard air-sprung suspension seat, air conditioning, spring-core mattress, ample stowage, a flat surface which may be used for a coffee machine, and a top quality finish. Megaspace Cabs come with a high roof, a level floor, stowage compartments in the instrument panel, above the windscreen and under the bed, suspension seat as standard, plus a wide, single-piece spring-core mattress.

Deluxe seat.

The luxury suspension seat features pneumatic lumbar support, side contour adjustment and seat heating. Both the angle and length of the seat cushion are fully adjustable, plus the backrest includes an integral head restraint and 3-point seat belt for extra safety.



Ergonomic controls.

The instrument cluster in the Actros offers an unsurpassed layout and readability. Analogue and digital displays deliver clear, concise information on speed, engine speed, fuel level and braking pressure. The user-friendly driver information system is operated using buttons on the steering wheel, enabling drivers to adjust settings and conduct diagnostic functions easily while displaying information on a large colour screen. Additionally the Telligent® gearshift lever is located on a fold-up arm rest on the left side of the driver's seat for added comfort and convenience.



Multifunction steering wheel.

The multifunction steering wheel enables drivers to operate the radio, telephone and driver information system without even having to take their hands off the wheel. The buttons can also be used to call up operational and service information. Plus the steering wheel can be fully adjusted telescopically and for rake angle.



Megaspace and high roof L-cabs feature spacious above-windscreen stowage compartments with optional hinged lids and interior lighting, as well as an optional 13-litre anti-theft valuables compartment. Under-bunk storage compartments feature internal and external access. For drivers travelling with healthy drinks and snacks, there is an option of a 25-litre roll-out cooler box which keeps contents at a cool 5°C.



Powerful engines give you more pull.

You can choose from four output classes of the Mercedes-Benz 500-series V6 engine, ranging from 265kW (360hp) to 350kW (476hp). There are three versions of the V8 ranging from 375kW (510hp) to 440kW (598hp). Depending on which configuration you choose,

the new Actros delivers up to 10% more power and up to 8.1% greater torque. In addition to gains in power, Actros engines are now more durable than ever. Modifications to the engines have eased thermal load on the pistons. Higher strength inlet valves and seat rings allow the valve

setting intervals to be extended. The crankcase breather features an improved oil separator, and the compact alternator and starter motor have both been designed for a longer service life.



Smart design lets you pull more.

When we say the Actros has been redesigned from the ground up, we mean it. Tyres, axles, frame, transmission – all have been re-engineered to optimise performance. Frame improvements include replacing head frame rivets with bolts so it is easier to exchange parts during repair. The front underride protection has been lowered and the headlamps have been moved further up to reduce the risk of chipping.

Most importantly, stronger backbone for better support on two axle trucks our optional integral rear section (standard with Megaspaces cabs) has freed up substantial room to attach components like extra fuel tanks, hydraulic pumps and compressors. Twin bellows air suspension further reduces weight by 30kg and allows for a number of design enhancements that improve handling dynamics and body roll. The Actros variants with steel suspension use weight optimised parabolic springs with maintenance-free rubber molecular bearings.

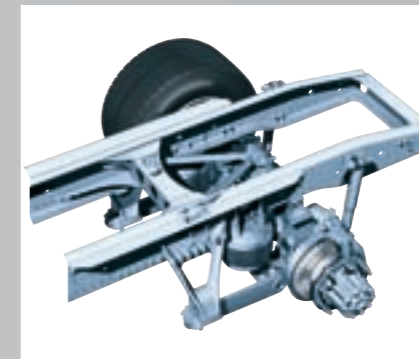

In addition, all variants are fitted as standard with shock absorbers and front and rear axle stabilisers. The leaf suspension is protected against corrosion, which makes an essential contribution to the long service life of the suspension system as a whole. Load up easily, drive safely. The standard-fit Telligent® level control allows the frame to be raised and lowered, in trucks with an air-sprung rear axle. Semitrailers or interchangeable systems can be attached and detached quickly and easily.



Advantages at a glance.

- robust, reliable design
- high torque at low rev speeds
- twin bellows air suspension = higher payload and improved handling dynamics
- Telligent® level control for raising and lowering the frame



You can never have too many safety systems

Total control and safety. But what else would you expect from Mercedes-Benz?

Driver safety never takes a back seat at Mercedes-Benz and Actros takes our long standing commitment to safety even further. The newly designed cab puts controls within easy reach, while the larger window improves visibility. The Actros also puts you in total control. Our Telligent® gear shift comes as standard and makes shifting effortless. Cleverly positioned

on the driver's seat, you can now comfortably change gears without taking your eyes off the road. Another new innovation is our braking system which comes with ABS and ASR (traction control) for outstanding stopping power. Actros also builds upon its legendary commitment to efficiency and economy, making it as affordable to operate as it is enjoyable to drive.

Telligent® gearshift and maintenance systems



PowerShift.

The Mercedes PowerShift is a fully-automated direct drive gear shifting system. Being fully-automated it provides the driver with a smoother, more economical drive. A clutch pedal is not required with the PowerShift and gear changes are performed by the control module at optimal times. Being automated not only reduces the workload on the driver. It also optimizes the drive, reducing the service requirements on the clutch, transmission and drivetrain.

Additional functions of Mercedes PowerShift.

- Power mode: permits short-term use of the full engine power.
- Eco-roll mode: assists in achieving fuel-saving operation in overrun conditions.
- Manoeuvring mode: offers precisely controllable power selection up to 1000 rpm using the accelerator pedal when manoeuvring.
- Rock-free mode: simplifies driving off on difficult ground.
- Extension of cruise control function 1 (speed range): offers individually adjustable vehicle speed range from 2 to 15 km/h between propulsion and brake cut-in.
- Extension of cruise control function 2 (separate vehicle memories): stores the setting for cruise control /autonomous cruise control and speed limiter separately, whereby the settings are preserved when switching between.
- High-speed reverse gears: allows higher speeds when reversing.
- Direct first-to-reverse shift: bypasses the intermediate step via neutral.

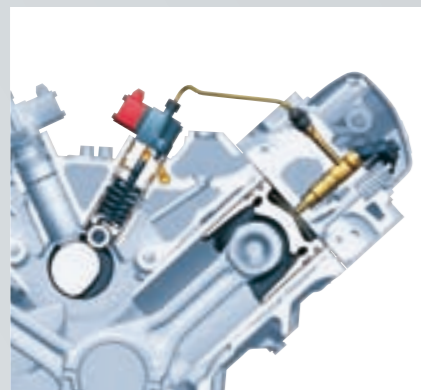

Telligent® engine control.

The revolutionary Telligent® electronic engine management system adjusts the injection of fuel with extreme precision to suit the driving situation. This optimised injection strategy, coupled with an injection pressure of up to 1800 bar, results in outstanding mixture preparation and efficiency.

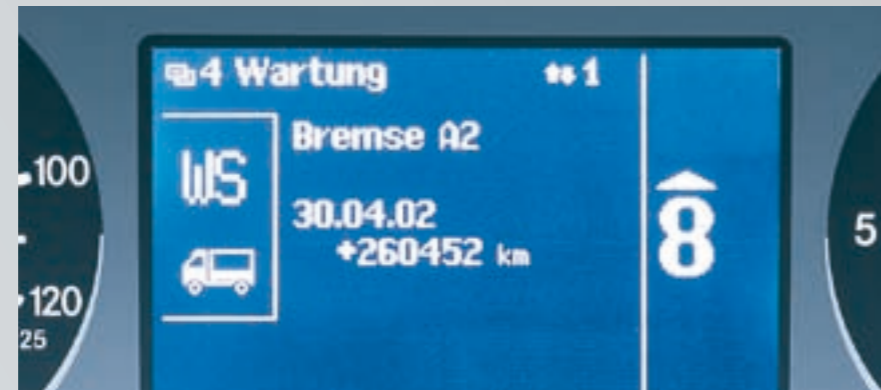

Telligent® maintenance.

The Telligent® maintenance system schedules service intervals according to the actual wear and tear on a vehicle. For instance, every single cold start is recorded. The condition of the engine oil and all major assembly oils, as well as the coolant level are monitored constantly. The system also shows when air or fuel filters need to be

changed and indicates brake pad wear. As a result, servicing and repairs can be scheduled more efficiently and more effectively, thus reducing downtime. Daily checks can be carried out quickly and easily from the comfort of the cabin, saving valuable time every morning.

Active and passive safety in the Actros

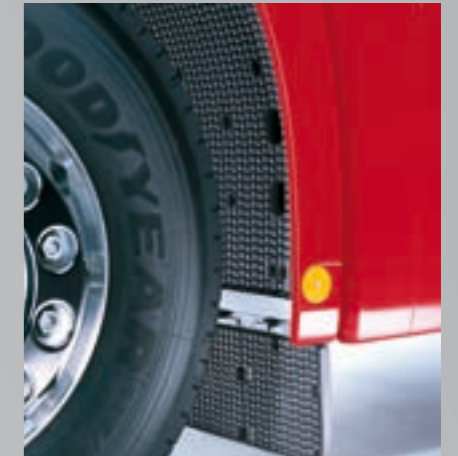

Built-in passive safety features.

In addition to optimal positioning of controls and larger windows for improved visibility, Actros also features clear-lens headlamps or optional xenon headlamps for unbeatable road illumination, heated exterior mirrors to prevent fogging and grooved channels in the wings to minimise spray from wet roads.

Telligent® active safety innovations.

Actros also offers a range of standard and optional active safety systems that can substantially reduce the risks of long-distance driving. The Telligent® braking system is standard and includes ABS and ASR (traction control), as well as internally ventilated disc brakes and 10-bar permanent brake pressure for outstanding stopping power. The system also features Brake Assist, which boosts braking power in emergencies and a hill holder function which prevents forward or backward rolling.

Advantages at a glance.

- low fuel consumption
- Telligent® braking system with hill-holder function
- new clear-lens headlamps
- xenon headlamps for unbeatable illumination of the road (optional)
- grooved wings to minimise spray from wet roads



Efficient to run.

Despite a substantial increase in performance, Actros still offers excellent fuel efficiency and economy. This is due in part to advanced technologies, such as the Telligent® electronic engine management system. It is also the result of an innovative approach to design and manufacture, including the introduction of turbochargers with a higher rate of air flow and the use of single-cylinder air compressors.

Economical to maintain.

Increased durability of parts, redesign of components to simplify repair or replacement, enhanced safety features and revolutionary technologies like the Telligent® maintenance system all contribute to reducing maintenance frequency and cost making the Actros as affordable to operate as it is enjoyable to drive.



Finance and insurance solutions.

Daimler Truck Financial

Through our national sales staff and customer support centre based in Melbourne, Daimler Truck Financial Services Australia Pty Ltd (DTFAu) offers a range of the most advanced finance products. DTFAu sales and support staff are thoroughly familiar with the light and heavy commercial vehicle market and can be of considerable help in selecting and tailoring the financial solution that's best for your business. DTFAu is part of the worldwide Daimler DTFAu Group, which means a dedicated, total commitment to Mercedes-Benz products and the people and companies who have chosen to use and rely on them. Through DTFAu you're offered the opportunity to run your vehicle or fleet with a flexible choice of finance options designed to help add value to your business, at highly competitive rates. As a vendor financier, DTFAu provides you with access to an alternative source of funds separate to traditional bank and finance company facilities. Through DTFAu you can take advantage of innovative, plain-language financing with simplified documentation that has been developed to answer the needs of all kinds of businesses.

Finance flexibility custom built to your business.

DTFAu is the only source of finance totally committed to supporting Mercedes-Benz Commercial Vehicles, which means DTFAu is totally committed to supporting you. We know you have more on your mind than finance. So in order to offer the most appropriate financial solution, we make it our business to understand yours. To this end, in conjunction with the dealer, we work closely with you to help develop finance and insurance solutions that truly match your needs. For example, structuring a lease arrangement to the length of a work contract, application or utilisation. A choice range of packages and a wide choice of options. We can help you choose which finance option and structure works best to meet your requirements. You can then rely on a prompt credit decision process with the finance arrangement being completed very quickly. Each finance option can take in variables, such as seasonal business, which can affect your day-to-day operations and cash flow. The end result is a DTFAu financing strategy that works best for you and the success of your business.



When you purchase an Actros you can always be assured that you are getting more than just a truck for your money. An extensive network of services is placed at your disposal. In other words, you have everything you – and of course your Actros – need to do your job as efficiently and reliably as possible.

Of course, it is a terrible shame that you will very rarely get to meet our service staff, if you ever get to meet them at all, that is. But then again, that's precisely what we're aiming for.