



This Brochure is prepared by Daimler AG and it predominantly reflects the capabilities and performance of vehicles sold in Europe. Some characteristics, capabilities, performance features and optional extras (e.g. towing systems) may not be available or may not apply in Australia or under Australian conditions. The information in this Brochure is therefore indicative, illustrative and provided only for guidance and should not be relied on. To obtain current and accurate information on a vehicle and any options applicable to Australia, contact your local authorised Mercedes-Benz dealer.

Mercedes-Benz



Mercedes-Benz

The C-Class

“Whether in driving refinement, design or safety – the C-Class is a genuine Mercedes. Experience it for yourself.”

Dr Dieter Zetsche

Contents

The C-Class	3	My C-Class	64
Agility	12	Design and equipment lines	66
TrueBlueSolutions	14	Standard	68
Diesel engines	16	ELEGANCE	74
Petrol engines	18	AVANTGARDE	80
Transmissions	22	AMG sports package	88
Suspension	24	Equipment	94
4MATIC	26	Standard equipment	94
Comfort	30	Light-alloy wheels	96
Interior	30	Audio and communication systems	100
Cockpit	32	Optional extras	101
Seating comfort	34	Standard equipment/ optional extras for estate	104
COMAND APS	36	designo	106
Ride comfort	38	Genuine accessories	110
Load compartment	40	Colours and materials	114
Safety	44	Paintwork	116
Integral safety concept	44	Upholstery and leather	118
AMG	56	Trim elements	120
		Combination options	121
		Technical details	122
		Saloon	122
		Estate	126
		Service and test drive	130

Get a new feel for the road

The C-Class. Agility and effortless superiority

Grey asphalt may not be one of life's most inspiring sights, but for over 120 years now, our vehicles have shown that it can give drivers a lot of fun. Reason enough, we thought, to go a step further and offer a new interpretation of driving pleasure. The result is the C-Class. Available as a saloon or an estate, it allows you to experience the road as never before. Few cars can compete with its ability to adjust so many facets of its character – from the interior to the drive technology – so quickly and precisely in response to external conditions and your own particular needs.

The advanced technology for the C-Class includes the standard-fit AGILITY CONTROL package with selective

damping as well as the optional dynamic handling package with a sports mode which allows you to adjust the vehicle's handling at the touch of a button. A wide range of engines (including a number of uprated units) means that the C-Class can be specified to meet just about any performance requirements while the estate offers the ideal combination of functionality and flexibility. Both models feature fine materials and an elegant design, creating an even more compelling interior ambience (whether this reflects a more sports-oriented character or a particular emphasis on comfort is entirely up to you). As you will see, in terms of its external appearance, too, the C-Class has, quite literally, several faces.



A mark of personality

The design of the C-Class AVANTGARDE

The C-Class impresses, both inside and out, with its distinctive design, spaciousness, high-quality materials and wide choice of paint finishes and upholstery patterns. What's more, you can choose which aspect of your C-Class you would like to highlight. The AVANTGARDE design and equipment line emphasises the car's sporty side. The dominant star in the radiator grille makes a powerful statement, while the chrome band which runs right around the body accentuates the taut lines of the C-Class.

A sure sign of style

The design of the C-Class ELEGANCE

The ELEGANCE design and equipment line brings the refinement and comfort of the C-Class to the fore. The characteristic star features as a free-standing element on the bonnet and the different chrome trim elements around the vehicle give the C-Class a particularly impressive presence. Tone-in-tone colour schemes contribute to the warm, pleasant atmosphere of the interior. Convex, chromed badges on the front wings designate the ELEGANCE and AVANTGARDE design and equipment lines which build on the classically stylish look of the standard-equipment version of the C-Class.















The C-Class



Your most enjoyable drive ever. Each time you get in

An agile look - right down to the last centimetre

The C-Class is a pleasure to behold: its taut lines lend it an air of effortless superiority while the wide radiator grille and distinctive rear section announce a vehicle with a real presence and a dynamic personality. But these compelling looks are only part of the story.

The C-Class is equipped with many innovative technical features which deliver a driving experience that is unique in this class. Think ease and confidence. Among the highlights is the AGILITY CONTROL package. This comprises AGILITY CONTROL suspension with a selective damping system which automatically adjusts the suspension set-up in accordance with the condition of the road - giving you a consistently high level of driving enjoyment.

As an option, you can order the ADVANCED AGILITY PACKAGE with its special sports mode which allows you to choose a particularly sporty suspension response or a distinctly comfortable one at the touch of a button.

And for a perfect driving experience not only on any road, but in any weather, too, you can choose the optional 4MATIC all-wheel-drive system. It is available for the C 280 and C 350 petrol-powered saloon models and for the C 320 CDI diesel versions of the saloon and the estate. As well as improving grip on wet roads when accelerating, for example, 4MATIC offers a noticeably more dynamic driving experience in the dry, too.

TrueBlueSolutions

Climate change is one of the major challenges of the 21st century. The rising consumption of natural resources is having an increasing impact on our planet. As the inventor of the motor car, Mercedes-Benz has a special responsibility to implement innovative technologies in order to develop solutions that help preserve the environment and ensure that raw materials are used as efficiently as possible – without compromising on comfort, safety and driving enjoyment. We call them TrueBlueSolutions.

Our goal is emission-free mobility. To achieve this goal, we have developed a number of concepts, one of which is **BlueEFFICIENCY**. This custom-designed package of efficiency measures can reduce fuel consumption by up to 12 %: various aerodynamic and energy-management measures are implemented individually for each model to maximise savings in each case. These include tyres with low rolling resistance, lightweight materials, changes to the body aerodynamics and the automatic ECO start/stop function. As for

diesel engines, Mercedes-Benz has brought to market its **BlueTEC** technology based on common-rail direct injection (CDI). This technology is the embodiment of the world's cleanest diesel as it can reduce nitrogen oxides by up to 80 %. Great things are also expected of **BlueHYBRID** technology - a combination of a highly efficient internal combustion engine and an electric motor. Vehicles equipped with this drive system raise the bar once again in terms of economy and cleanliness, as will be shown by the S-Class from 2009 onwards. Mercedes-Benz calls the equivalent technology for diesel vehicles **BlueTEC HYBRID**. A prototype



BlueTEC. The world's cleanest diesel technology in a modern-day vehicle. The E-Class is also available with BlueTEC technology

version of this system can be seen in the Vision GLK 300 BlueTEC HYBRID¹, which is currently the world's cleanest and most economical SUV. It returns a combined consumption figure of just 5.9 l/100 km. And with the F700 research vehicle, we have succeeded in combining the advantages of a petrol engine with those of a diesel powerplant. The **DIESOTTO** drive at the heart of the F700 may have petrol in the tank; however, it operates like an economical diesel model in many driving situations. Mercedes-Benz also sees great potential in the development of the fuel cell. This highly promising drive system requires no



BlueEFFICIENCY. Numerous models, various measures, one goal: maximum efficiency

mineral fuel whatsoever and operates with zero emissions. The first of these vehicles to be built under series-production conditions – the B-Class F-CELL – is due in 2010.

However, our extensive TrueBlueSolutions concept does not just include new drive technologies. Under the banner **Design for Environment**, we look at the vehicle's entire lifecycle – from planning to recycling. The same applies to the building and running of new plants. We save energy, avoid pollutants and increase the use of renewable raw materials. Incidentally, Mercedes-Benz is the



BlueHYBRID. Looking forward to one of the world's most economical luxury saloons. The S-Class from 2009

world's only car brand to have received the independently awarded TÜV² environmental certificate. TrueBlueSolutions also involves the active participation of the Group and its employees in environmental protection measures both inside and outside the company's plants. And it incorporates a commitment to developing second-generation alternative fuels (BTL/Biomass-to-Liquid fuels), such as SunDiesel[®], which are not at odds with food production. Another aspect of TrueBlueSolutions is the research discipline of bionics, which looks at structures and designs in the natural world in order to optimise the



BlueTEC HYBRID. The Vision GLK 300 BlueTEC HYBRID¹ is the most efficient combination of BlueTEC diesel and hybrid modules

weight and aerodynamics of body constructions, for example. Last but not least, you can also do your bit for TrueBlueSolutions by adapting your driving style.

For further information on our extensive package of measures, go to www.mercedes-benz.com/truebluesolutions

¹ Provisional figures: combined fuel consumption: 5.9l/100 km; overall CO₂ emissions: 157 g/km

The figures are not based on an individual vehicle and do not constitute part of the product offer; they are provided solely for purposes of comparison between different vehicle models

² TÜV SÜD Management Service GmbH, Munich



F-CELL. Emission-free mobility with the drive system of the future: the B-Class F-CELL goes into production in 2010



Engines with the power to move you

The C-Class diesel models with common-rail technology and particulate filter

Six efficient and powerful CDI engines are available for the C-Class. The C 320 CDI boasts a six-cylinder common-rail unit with an output of 165 kW (224 hp) which accelerates the car from 0 to 100 km/h in 7.7 seconds (estate: 7.9 s).

The C 200 CDI and C 220 CDI four-cylinder diesels have extra power and considerably higher torque thanks to numerous technical innovations. The C 200 CDI now has an output of 100 kW (136 hp) and the C 220 CDI 125 kW (170 hp).

Particularly environment-minded drivers will welcome the C 200 CDI BlueEFFICIENCY or our new special model, the C 250 CDI BlueEFFICIENCY “Prime Edition”.

The 4-cylinder diesel engine in the special model delivers particularly impressive performance with outstanding power and torque figures (150 kW and up to 500 Nm) combined with excellent fuel efficiency and high environmental compatibility thanks to its compliance with the EU 5 exhaust emissions standard. Both models share a raft of intelligent measures which reduce their weight, drag and rolling resistance and also feature optimised energy management technology which offers significant reductions in both fuel consumption and CO₂ emissions.



Numerous efficiency-enhancing measures in the BlueEFFICIENCY models ensure reduced fuel consumption and lower CO₂ emissions

It's more than engineering. It's performance art

4-cylinder supercharged petrol engines

You can choose between nine different petrol engines for the C-Class. The range begins with two 4-cylinder supercharged models. The C 180 KOMPRESSOR BlueEFFICIENCY has an output of 115 kW (156 hp) and a maximum torque of 230 Nm while the C 200 KOMPRESSOR delivers no less than 135 kW (184 hp) and 250 Nm. Acceleration from 0 to 100 km/h takes just 9.5/8.6 seconds (estate: 9.8/8.8 s) and the respective top speeds are 230/235 km/h (estate: 223/228 km/h).

As well as featuring an engine optimised for fuel economy, the C 180 KOMPRESSOR BlueEFFICIENCY is notable for an extensive package of fuel-saving measures concerning its weight, aerodynamics and tyres. The result is a vehicle which offers a significant reduction in fuel consumption

and which provides a timely demonstration that high comfort and typical Mercedes-Benz safety can still be assured even if the basic parameters are changed.

C 200 KOMPRESSOR

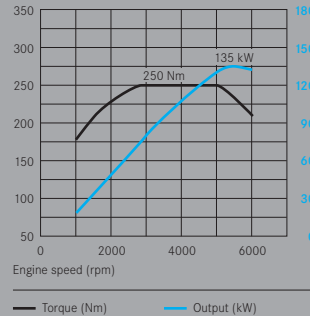

With a 15 kW (21 hp) increase in output and an extra 10 Nm of torque, the C 200 KOMPRESSOR now accelerates even more powerfully across the entire engine speed range



If it all went too fast for you out on the road, catch up on the facts and figures here

The V6 petrol engines: the strong, silent types

The 6-cylinder powerplants in the C 230, C 280, C 350 and C 350 CGI BlueEFFICIENCY are paragons of refined performance. Their respective maximum torque of 245, 300, 350 and 365 Nm is available across an exceptionally broad engine speed range, ensuring that you always have impressive power reserves to call on.

Exemplary fuel use is common to all the V6 engines, thanks to four precisely adjustable camshafts whose timing can be optimised in line with changing requirements. This system ensures that the engines are always provided with exactly the right amount of fuel for the driving situation.

The C 230 develops 150 kW (204 hp), the C 280 170 kW (231 hp) and the C 350 puts more than 200 kW (272 hp) on tap. Despite its impressive 215 kW (292 hp) output, the new C 350 CGI BlueEFFICIENCY with direct petrol injection actually consumes ten percent less fuel than

comparable six-cylinder petrol units. At the same time, its acceleration figures are worthy of a sports car: 0 to 100 km/h in 6.2 s.

The versions equipped with V6 engines, which use fuel particularly sparingly, can be identified externally by the dual-flow exhaust system.

C 350

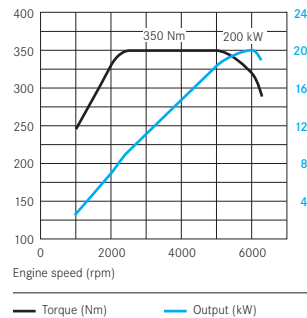

The C 350 with a maximum torque of 350 Nm and an output of 200 kW (272 hp)



We've stepped up a gear or two so that you can enjoy faster shifting

Transmission technology in the C-Class

The C-Class is fitted as standard with a 6-speed manual transmission with very short shift throw which makes gear changes a joy. The ratios in the C 320 CDI are specially tuned to this model's high torque, which peaks at 510 Nm. All 4-cylinder models are also equipped with a gearshift recommendation for optimal fuel efficiency, while all C-Class models boast a display of the current fuel consumption.

The C-Class can offer even faster gear changes. A 5-speed automatic transmission is available as an option for the 4-cylinder models. The highlight of our transmission range, the 7G-TRONIC 7-speed automatic transmission, is standard in the C 350, C 350 CGI BlueEFFICIENCY and C 63 AMG as well as the 4MATIC models, and available as an option for all other 6-cylinder models. The seven forward gears permit optimum rev levels at all times and make for almost imperceptible gear changes. 7G-TRONIC can also skip individual gears when downshifting for quicker bursts of speed.



A nice touch: If your car is fitted with an automatic transmission and you want to change up or down a gear manually, simply nudge the selector lever to the right or left



Even more compelling driving at the touch of a button

The dynamic handling package for the C-Class

The dynamic characteristics of the C-Class set the standard by which all vehicles in this segment are judged – a standard which is raised even further by the optional dynamic handling package with a sports mode. A touch of a button is all it takes to choose a distinctly comfort-oriented driving experience or a compellingly sporty one. With sports mode selected, the system adjusts not only the firmness of the damping, but also sharpens the accelerator response. Assuming, of course, that you are in the mood for it. Otherwise, you can simply choose the comfort mode and enjoy a particularly smooth and comfortable ride.

Whatever the selected mode, the electronically controlled damping system constantly adjusts to the driving situation and the condition of the road. The result is a smoother ride, increased handling safety and, above all, greater agility. The dynamic handling package includes innovative

speed-sensitive sports steering which uses a modified steering response map to deliver a particularly sporty feel. This sensation is complemented by the lower-slung chassis (15 mm lower) which makes fast bends even more enjoyable.



Dynamic handling package: The dynamic handling package allows you to match the C-Class to your mood. A touch of a button is all it takes to give the vehicle a distinctly sporty handling response. Vehicles equipped with 7G-TRONIC benefit from an additional, noticeable reduction in shift times



The C-Class makes the best of bad weather

High traction with 4MATIC all-wheel drive

When contending with loose gravel, snow or challenging inclines, 4MATIC all-wheel drive distributes the engine power to the wheels that need it most. It interacts intelligently with the Electronic Stability Program ESP®, acceleration skid control ASR and the 4MATIC-specific electronic traction system 4ETS to increase both directional stability and traction – particularly where road conditions are difficult.

4MATIC permanent all-wheel drive is available for the C 320 CDI, C 280 and C 350 Saloons as well as for the C 320 CDI Estate. All 4MATIC models are equipped as standard with the 7G-TRONIC 7-speed automatic transmission.

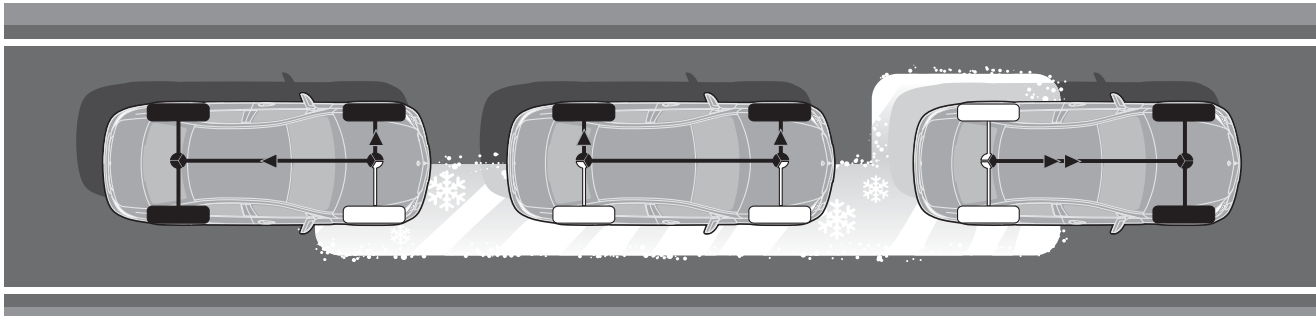

4ETS: In the 4MATIC models the ETS electronic traction system is adapted to the special requirements of all-wheel drive. It automatically diverts the drive torque to the wheels with the best grip





C350



S ON3811





Why long trips are going to seem much too short from now on

The interior of the C-Class

With its soft materials, fine trim elements and more space than ever, the interior of the C-Class is particularly inviting. Shoulder and elbow room has been increased, and rear passengers will also quickly feel at home thanks to their increased legroom. The exceptional ambience of the interior is heightened further by numerous attractive design details with chrome, wood or aluminium trim, depending on the model and your preferences. With a wide range of optional equipment highlights to choose from, including the panoramic sliding sunroof, which features a particularly large glass area, driving the C-Class is a joy that, quite literally, knows no bounds.



Take a seat: The firmness of the lateral and upper-leg support areas of the seat cushions helps to keep you fresh and alert when on the move



You've worked hard enough. Now it's our turn

Stress-relieving comfort in the C-Class

A driving environment which allows you to concentrate on the task in hand is not just a luxury, it is also a major safety feature. It all starts with the well-designed driver's area. The dashboard allows you to take in all the necessary information at a glance. The instrument cluster, with its three round displays, is situated in the driver's immediate field of vision and provides information about key operating parameters. Depending on the equipment version, you can use the multifunction steering wheel for easy and convenient control of various features while keeping both hands on the steering wheel. And with the optional KEYLESS-GO function, you can drive off without even having to turn an ignition key.

A comfortable travelling environment comes courtesy of the 2-zone automatic climate control THERMATIC which is fitted as standard in the C-Class. As an option, you

can order the 3-zone luxury automatic climate control THERMOTRONIC which, among other things, allows the temperature of the rear section of the passenger compartment to be set independently as well.



An easy touch: The instruments and systems have intuitive controls. The press of a button is all it takes to adjust audio settings, in-car entertainment selections or, here, the temperature

Soft on the outside, firm on the inside

The secrets of exceptional travel comfort

Equipped on the driver's side with a lumbar support for enhanced lower-back comfort, the ergonomic front seats are electrically adjustable for cushion height and backrest angle. These settings, in combination with others such as the steering wheel position, head restraint height and exterior mirror position, can be stored by means of the optional memory package. This allows three different configurations to be recalled at the touch of a button.

Also available as an optional extra, the multicontour seat has adaptive air chambers for even greater comfort.

As a result, you can adjust the side bolsters of the seat cushion and backrest as well as the lumbar support to meet your individual comfort and health requirements.

If it's the dynamic side of the C-Class that interests you most, there's the optional AMG sports package which includes seats with more pronounced contours for even greater lateral support. Other optional extras include leather upholstery. Depending on the line, this is available in the form of either man-made leather or genuine leather in a choice of attractive colours.







Typical Mercedes: a navigation system that's a real turn for the better

The COMAND APS multimedia navigation system

The optional COMAND APS multimedia system guides you directly to your destination, helping you to arrive fresh and composed. It combines audio, telephone and navigation functions. Thanks to its interface, COMAND APS is now more intelligent and user-friendly than ever – despite having considerably extended functionality.

The pivoting 7-inch display with graphic elements and colours is now at the same level as the instrument cluster and is therefore ideally positioned in the driver's field of vision. COMAND APS can be controlled either via an input array in the centre console or via the controller which falls conveniently to hand in front of the armrest. Moreover, all key functions can now also be called up by means of a voice-recognition function: the destination input section of the navigation system has whole-word recognition capability for all place names and road names; a stored telephone number can be dialled simply by saying the name associated with it and you can even set the system

up to read out your text messages. Bluetooth functionality is also integrated to allow safe hands-free mobile phone operation and the DVD player is compatible not only with video and audio DVDs, but with CDs and MP3 files too. Up to 1000 MP3 music tracks can be stored on the hard disc of the navigation system.



All at your fingertips: The armrest is designed in such a way that the controller automatically falls to hand. It offers a particularly fast, easy and intuitive way of adjusting the full range of COMAND APS settings



A chauffeur-driven feel

The C-Class: setting the benchmark for comfortable suspension and low noise levels

The C-Class has always been synonymous with outstanding ride comfort. With every new model generation, the aim of our engineers is to raise the standard yet again. This is why the C-Class now features a selective damping system. The standard-fit AGILITY CONTROL package automatically adjusts the dampers at each wheel to a harder or softer setting according to the current driving situation, ensuring a significantly smoother ride than conventional dampers, especially on poor road surfaces.

Low interior noise levels are a prerequisite for a relaxing driving experience. To eliminate wind noise from the C-Class interior even more effectively, we have optimised the shape of countless bodywork details and further improved the sound insulation.

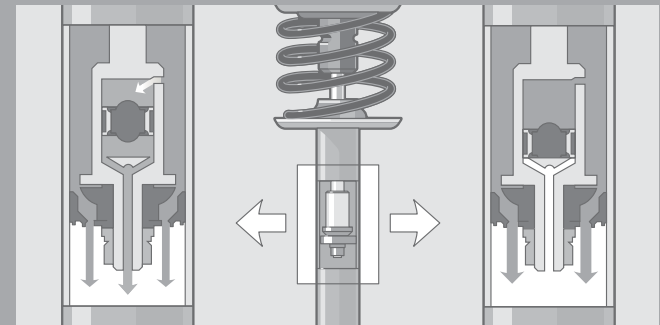

Selective damping system: Softer shock absorber characteristics ensure an extremely smooth ride in normal mode. For dynamic driving the full damping force is made available to stabilise the vehicle



If you need more space, we have the real estate

Simply more possibilities

Every day brings its challenges, be they large or small, personal or professional. It is only natural, therefore, that anyone who wants to be prepared for any situation should set particularly high standards when it comes to choosing an estate, not least with regard to the variability of the load compartment. So we took special care to address these needs comprehensively during the development of the C-Class Estate – with the handy stowage nets, the 485 to 1500-litre load capacity (particularly impressive in this segment) and the EASY-PACK load-securing kit. All the details have been fully thought-out and are geared to the same objective: ensuring your comfort.

The C-Class Estate also impresses with its extremely high payload of up to 605 kg¹ as well as its remarkable towing capacity of up to 1800 kg. What's more, when you make use of the latter, you benefit from the additional safety offered by the trailer stabilisation functionality of the vehicle's ESP® system. A range of options, including automatic opening/closing functionality for the tailgate and a new type of self-levelling suspension for optimum load compensation, enhances the everyday practicality of this all-rounder even further.

¹As per DIN





A high-angle, close-up photograph of a brown leather-bound book. The book is positioned diagonally on a dark, metallic surface with a fine, scratched texture. The cover of the book is embossed with the text "THE INTEGRAL SAFETY CONCEPT" on the top line and "FROM MERCEDES-BENZ" on the bottom line. The leather has a subtle grain and is finished with a double-stitch border. The spine of the book is visible on the left, showing the thickness of the pages. The lighting is dramatic, casting a soft shadow to the left of the book.

THE INTEGRAL SAFETY CONCEPT
FROM MERCEDES-BENZ

A theory which can save lives in practice

The integral safety concept from Mercedes-Benz

Few, if any, fields of activity inspire us to produce such consistently impressive results as researching new safety technologies. As early as the 1950s, we passed an important safety milestone when legendary vehicle safety pioneer Béla Barényi invented the passenger safety cell.

This era also saw revolutionary ideas put forward by many others – such as Rolf Maier. In order to be able to study the crash performance of steering and restraint systems quickly and cost-effectively, Maier and his engineer colleagues designed and built a special sledge which was to be driven into a wall at high speed. When they needed to create a crumple zone, the team came up with a simple, yet brilliant solution: gherkin tins from the staff restaurant – a typical example of the creative spirit which characterised this pioneering time.

Much as we like to reflect on the past, though, our focus has always been firmly on the future. The best example is our vision of accident-free driving, which is nearer today

than ever before thanks to PRO-SAFE™. This integral safety concept from Mercedes-Benz divides automotive safety into four phases.

To ensure a safe journey throughout, the vehicle helps the driver to identify critical situations promptly and handle them better. In the second phase, where a risk has been detected, numerous preventive measures can be activated to reduce the risk of injury. In the event of an accident, the occupants can benefit from effective, individualised protection provided by the comprehensive range of passive safety systems. Finally, the fourth component comprises the phase after the accident when further measures come into play – to make the task of the rescue services easier, for example.

Further information about the Mercedes-Benz safety concept is available online at www.mercedes-benz.com/airbag-brochure



Focusing on helping you to stay focused

Drive more safely, and avoid dangers before they have a chance to develop

The majority of accidents start long before the actual collision: with a lapse in concentration, poor visibility or an unexpected hazard. The C-Class is therefore fitted with safety systems which promote relaxed motoring and help you to bring critical situations under control.

For example, the COMAND APS multimedia system as well as the voice-operated control system LINGUATRONIC, both of which are available as options, allow you to keep both hands on the steering wheel. When driving, you can also count on over 60 electronic support systems. Some are designed to alert you in the event of a problem – the tyre pressure loss warning system, for example. Others are there to provide active assistance, such as the Electronic Stability Program ESP®, Brake Assist (BAS) and, for the first time in the C-Class, ESP® trailer stabilisation. The ESP® and BAS sensors can detect hazardous driving situations – such as pronounced oversteer or understeer, dramatic steering movements, emergency and panic braking – and

can assist the driver accordingly. You are also kept informed about the safety status of your passengers. The standard belt status display for the rear seats in the instrument cluster gives you a visual signal if a passenger has forgotten to belt up.

Driving in the dark becomes an experience to relish with the optional Intelligent Light System, based on the bi-xenon headlamps. It automatically adapts the low-beam lights to the given driving situation, improving long-range visibility on motorways and providing broader illumination on other roads. The Intelligent Light System also includes enhanced fog lamps, which significantly improve illumination of the driver's side of the road. Other components of the Intelligent Light System include the active light and cornering light functions. With these, the headlamps follow your steering movements, lighting up bends in the road more effectively.

Some hazards arise in next to no time. Some protective systems are even faster

The PRE-SAFE® anticipatory occupant protection system

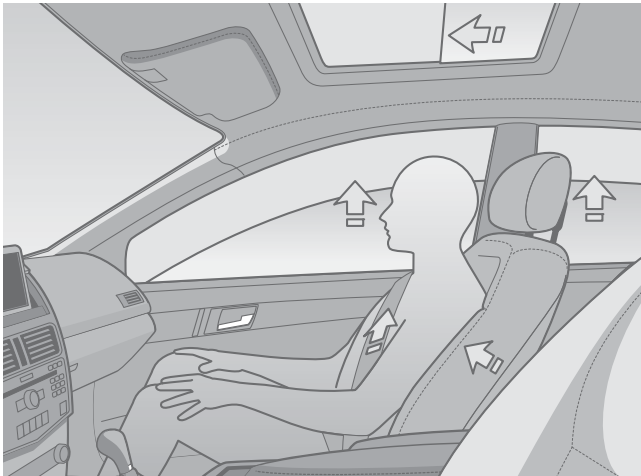

Mercedes-Benz presented PRE-SAFE® in 2002 with one particular objective in mind: the valuable seconds which precede an accident usually elapse unused. The optional PRE-SAFE® system is designed to make effective use of them. The ESP® and BAS sensors identify potentially dangerous situations such as strong oversteer or understeer, critical steering movements, panic braking or emergency braking.

PRE-SAFE®: If there is an immediate danger of an accident occurring, the optional PRE-SAFE® system can tauten the seat belts, close the side windows and the optional tilting/sliding sunroof or panoramic glass roof and move the front passenger seat into a more favourable position (in conjunction with electrically adjustable seats and memory package)





PRE-SAFE® electronically evaluates this information and, when faced with situations which are typically associated with hazards, it triggers precautionary measures to protect the occupants – including automatic tautening of the front seat belts, automatic repositioning of the front passenger seat (provided it is electrically adjustable and equipped with the memory function) and automatic closure of the side windows and the optional tilting/sliding sunroof or panoramic glass roof.

In the event of emergency braking, the adaptive brake lights are also activated, their flashing mode providing more of a warning to traffic behind than conventional brake lights.

If it comes to the crunch, you can trust Mercedes to cushion the blow

Restraint systems and the passenger safety cell can protect you and others effectively in an accident

Numerous occupant protection systems can significantly reduce the risk of injury in an accident. In the event of a rear-end collision, for example, sensors cause the standard-fit NECK-PRO head restraints for the driver and front passenger to deploy in a matter of milliseconds to reduce the distance between the seat occupant's head and the head restraint.

The C-Class is equipped with belt tensioners on the front and outer rear seats, plus numerous airbags, including two-stage driver's and front passenger airbags, sidebags, and windowbags whose protection zone covers virtually the entire area of the side windows. The sidebags and if the door deforms in a side-on collision, the increase

windowbags are also triggered by pressure sensors: in air pressure between the outer door panels and the interior of the door is registered by the pressure sensors, which assist the control unit in deploying the airbags.

Protection also extends to other road users, however, thanks to features such as smooth body surfaces with a generous degree of predefined yield.

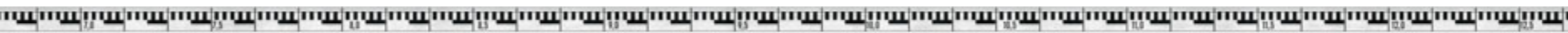

Your Mercedes may have been immobilised, but that doesn't mean it can't still help you

Safety after the event: helping to minimise further damage and speed up the rescue effort

In order to prevent further damage being caused following an accident and to assist with the task of rescuing the occupants, the C-Class is able to take various measures depending on the type and severity of the accident: the engine can be turned off automatically and the fuel supply cut. The hazard warning lights and emergency interior lights can be activated automatically, the side windows partially lowered, if necessary, and the doors automatically unlocked. To complete its holistic safety philosophy, Mercedes-Benz has also published multi-lingual rescue guidelines (accessible online worldwide at www.mercedes-benz.com/rescue-guidelines) as an additional aid for the emergency services.

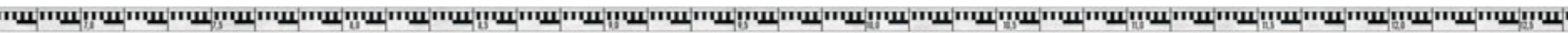
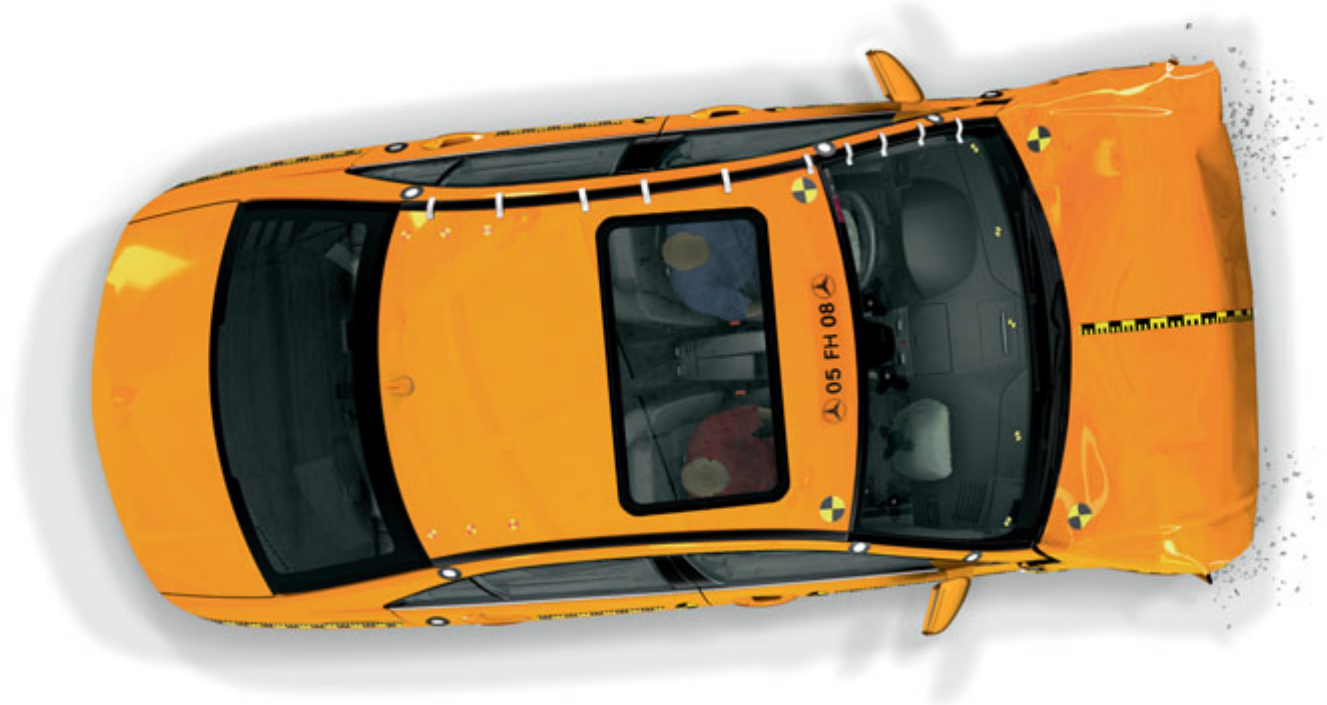



C 320



CDI

S ON 1464



M.F.F.

Hellelyst

GAS

Steng hovedkyl
for ombordkjø

Please close
valve before

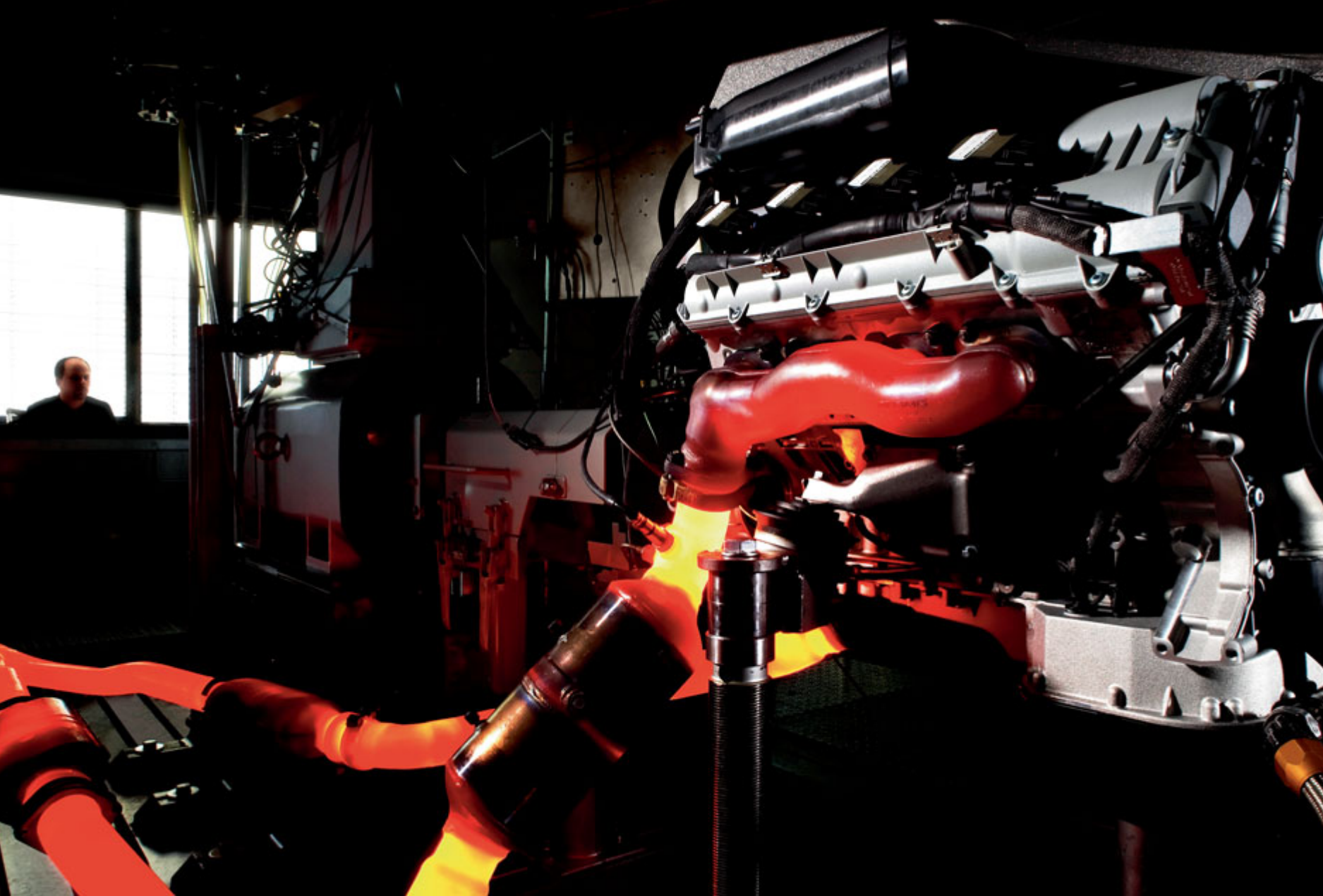

Precision is the hallmark of AMG, passion is its driving force

Mercedes-AMG: the motorsport specialists

“One man, one engine” – this philosophy embodies the sense of passion and commitment which strikes anybody who visits the facility in Affalterbach where the AMG engines are crafted. Because each engine – from the installation of the crankshaft to the filling of the oil – is the responsibility of a single experienced engineer. As a result, this specialist unit is able to ensure the highest quality and reliability for its products. And just so you know who was responsible for the powerplant of your AMG Mercedes, the engine is fitted with a plate bearing the signature of its creator.

Mercedes-AMG has a long tradition of precision engineering. More than 40 years ago, company founders Hans Werner Aufrecht and Erhard Melcher turned their passionate interest in automotive engineering into a business: they brought motorsport to the road. Today, AMG creates not only high-performance engines, but also entire vehicle concepts designed to underline the sporty dimension of a Mercedes in every respect.



The sportiest C-Class of all time

The C 63 AMG

A 6.3-litre naturally aspirated V8 engine, 336 kW (457 hp), 600 Nm of torque, 0 to 100 km/h in 4.5 seconds (estate: 4.6 s), top speed 250 km/h – the specification and performance data of the C 63 AMG speak for themselves. But the only way to really appreciate the calibre of this exceptional vehicle is to drive it. The fifth generation of the AMG C-Class offers a perfect blend of extraordinarily impressive performance and expressive design. Outstanding power and agility are ensured by the combination of the AMG V8 engine and the perfectly matched AMG sports suspension with a wider front axle and AMG speed-sensitive sports steering. The 7-speed AMG SPEEDSHIFT PLUS 7G-TRONIC automatic transmission ensures optimum delivery of engine power to the road, enhances driving dynamics with its ultra-smooth downshifts and makes for an even more enjoyable drive with its throttle-blip function. The new, specially optimised three-stage Electronic Stability Program

ESP® and the AMG high-performance brake system also play key roles in delivering a safe and enjoyable driving experience. But the really great thing about the C 63 AMG is that it is a genuine Mercedes-Benz in every respect – with all that that implies with regard to long-distance comfort, handling and safety – and offers an ideal combination of high performance and everyday practicality.





It's a C-Class, but not as you know it

It only takes one glance to appreciate the exceptional power of the C 63 AMG. The front view is dominated by the two pronounced powerdomes as well as the special AMG radiator grille with its central star and louvres. The front fog lamps at the outer edges of the front apron emphasise the width of the vehicle, as do the flared front wings. The side air vents in the front apron provide an outlet for the heat from the additional oil cooler. When equipped with the optional bi-xenon headlamps or the Intelligent Light System, the C 63 AMG features dark-tinted headlamp lenses.

The side view is dominated by the high-sheen 18-inch AMG light-alloy wheels painted in titanium grey, as well as the attractively integrated "6.3 AMG" legend on the wings and the AMG side skirts. At the back the tone is set by characteristic brand design cues: the AMG rear apron with its black diffuser insert and three distinctive diffuser fins as well as the AMG sports exhaust system with two

chromed twin tailpipes and standard-fit LED rear lights. The AMG spoiler lip on the boot lid reduces lift and provides greater directional stability and road adhesion.

Exclusive optional features are available for the C 63 AMG from the AMG *PERFORMANCE STUDIO*. These include the AMG performance package, high-sheen 19-inch multi-spoke AMG light-alloy wheels painted in titanium grey and AMG carbon-fibre trim elements.





An interior full of sporty highlights

Inside the C 63 AMG, exclusive AMG sports seats with integral head restraints and adaptive backrests are fitted as standard. Upholstery is available in ARTICO man-made leather/AMG fabric in black and alpaca grey. If optional fine nappa leather is ordered for the upholstery of these seats, the door centre panels and door armrests are also finished in nappa leather, the available colour combinations being black, alpaca grey or black/sahara beige. Exceptional sportiness is also the dominant theme throughout the rest of the interior. The cockpit features an AMG instrument cluster with the characteristic tubular design while the three-spoke AMG performance steering wheel has a flattened lower segment and is equipped with authentic motorsport-style shift paddles. AMG door sills, aluminium

trim elements, the black roof lining and the brushed stainless-steel sports pedals complete this distinctly sporty interior.







My C-Class



The C-Class from its three most attractive sides

Standard equipment and the ELEGANCE
and AVANTGARDE design and equipment lines



The C-Class is packed with technology which automatically adjusts to the driver and his or her driving style. And its design and equipment lines are intended to reflect your personal style too – whether you prefer a classic, elegant or avant-garde look.



Standard equipment

One look at the exterior of the C-Class is enough to confirm that it has all the typical Mercedes-Benz characteristics: the chromed radiator grille is embellished with the laurel wreath badge with the hallmark star standing above it on the bonnet. Fine chrome defines the top of the window areas and three black louvres add emphasis to the front air intakes. The fog lamps also have black surrounds.



Chromed and black trim elements characterise the front of the C-Class

The colour concept continues all the way to the rear with the wide matt black handle.

The C-Class is also equipped with attractive light-alloy wheels in a 7-spoke design as standard.



Matt black is used for the boot lid handle



Standard equipment for the C-Class Estate

Featuring a chromed radiator grille embellished with the laurel wreath badge and the star standing on the bonnet, the standard-equipment version of the C-Class Estate has all the inimitable exterior characteristics of a genuine Mercedes-Benz. This version is made all the more attractive by the three black air-intake louvres and the front fog lamps which also have black surrounds. The black roof rails and the matt-black tailgate handle also complement the harmonious colour scheme. What's more, attractive light-alloy wheels come as standard.

The exterior design concept is taken up by the interior which has a classic black or alpaca grey finish. High-quality chrome details complement the fine trim elements with their piano-lacquer-effect finish (burr walnut is available as an alternative) to further enhance the stylish ambience. The seats are upholstered in Brighton fabric in black, alpaca grey, black/beige or black/red while

ARTICO man-made leather upholstery is available as an optional extra.



High-quality materials are used in the load compartment, too



Standard equipment – the interior

The interior, too, retains its classic feel, finished either in black or alpaca grey. Fine piano-lacquer-effect trim elements are supplemented with high-quality chrome details. The trim elements are also available in burr



Numerous chrome details harmonise with the piano-lacquer-effect trim elements

walnut as an option. Specially designed with horizontal seamlines, the seats are upholstered in black, alpaca grey, black/beige or black/red Brighton fabric, but can be finished in ARTICO man-made leather as an option.



Comfortable and elegant: the seats with their attractive fabric panels



The ELEGANCE design and equipment line

The first time you set eyes on your C-Class ELEGANCE is a very special moment. From the star standing on the bonnet, your gaze travels to the fog lamps with their elegant chrome surrounds. More chrome elements can be seen on the bumpers, wings and doors. The polished



Numerous chrome trim elements lend the front its elegant character

aluminium shoulderline trim strip adds a particularly stylish highlight to the sides of the C-Class. The rear of the C-Class ELEGANCE is distinctive with its chromed handle. 12-spoke light-alloy wheels provide a dazzling finishing touch.



Gleaming chrome is also used for the boot lid handle



The ELEGANCE design and equipment line for the C-Class Estate

Truly elegant design is always eye-catching – as in the case of the front section of the C-Class ELEGANCE, for example. The distinctive headlamps and the fog lamps with their attractive chrome surrounds set the tone for the thoroughly elegant statement made by the chrome details on the bumpers, wings and doors and reinforced by the polished aluminium shoulderline trim strip and roof rails.

The tailgate of the C-Class ELEGANCE is equally striking with its chromed handle, while 12-spoke light-alloy wheels provide a dazzling finishing touch. Subtle colours characterise the interior. The Edinburgh fabric is available in black, alpaca grey or almond beige. ARTICO man-made leather or genuine leather upholstery can be ordered as optional extras. Burr walnut can be specified as an option instead of the standard fine-grain eucalyptus wood trim elements. Both harmonise beautifully with the stylish

leather steering wheel, which is standard in this design and equipment line.



The elegant design extends to the load compartment, too



The ELEGANCE design and equipment line – interior

Inside, the tone is set by a discreet combination of colours. The Edinburgh fabric is available in black, almond beige or alpaca grey. As an option, the comfortable seats can also be upholstered in ARTICO man-made leather or genuine leather. A leather steering wheel is fitted as standard.



The natural beauty of the eucalyptus wood trim elements

Upholstered in fabric or leather, the seats have decorative vertical stitching and the trim elements are in fine-grain eucalyptus. The interior can also be trimmed in burr walnut as an option.



The seats can be upholstered in leather – for example in alpaca grey – as an option



The AVANTGARDE design and equipment line

The AVANTGARDE design and equipment line turns the C-Class into an even more distinctive Mercedes. The agility of this model is conveyed instantly by the look of the front featuring a wide radiator grille with three bright silver louvres, distinctive chrome strips and the dominant star set in the centre. Chrome highlights – on the bumpers,



Striking and powerful: the face of the AVANTGARDE line

wings and doors, for example – emphasise the elegant profile of the C-Class and are complemented by the polished aluminium shoulderline trim strip and the chromed handle at the rear. Dark-tinted tail lights are another distinctive feature of the rear of the C-Class AVANTGARDE.



Embellishments at the rear include a chrome handle



The AVANTGARDE design and equipment line for the C-Class Estate

Avant-gardists always stand out – and the C-Class AVANTGARDE is no exception, its front instantly conveying the vehicle's agility through its wide radiator grille with three bright silver louvres, and the dominant star set in the centre. Chrome highlights on the bumpers, wings and doors emphasise the sleek lines of the C-Class. Particularly eye-catching touches include the polished aluminium shoulderline trim strip and roof rails as well as the chromed handle at the rear and the chrome band which runs round the whole vehicle.

Sportiness is the dominant theme inside the vehicle: the dashboard and floor are black while the door centre panels and door armrests are black or alpaca grey. Matt aluminium trim elements underline the sporty look. Wood trim elements in black bird's-eye maple are available as an option. The sporty theme continues with the standard Liverpool fabric/ARTICO man-made leather upholstery in black or alpaca grey.

Leather upholstery in black, alpaca grey, black/sahara beige or black/cognac brown is available as an optional extra.



The sporty look and feel is carried through to the load compartment



The AVANTGARDE design and equipment line – interior

Contrasting colours and materials lend the interior its sporty character. The floor and dashboard are black while the door centre panels and door armrests are black or alpaca grey. Finely textured aluminium trim elements emphasise the clean, sporty look. Wood trim elements in black bird's-eye maple are available as an option. The seats are distinguished by horizontal stitching and

are upholstered as standard in a Liverpool fabric/ARTICO man-made leather combination in black or alpaca grey. Optional appointments for the C-Class AVANTGARDE include two-tone leather upholstery with the black/sahara beige or black/cognac brown colour combination adding a particularly striking touch.



Aluminium trim for a refined, sporty look



The horizontal stitching adds to the dynamic ambience



	Standard	ELEGANCE	AVANTGARDE
Exterior			
B-pillar trim	Matt black	High-gloss black	High-gloss black
Boot lid handle	Matt black	Chromed	Chromed
Bumpers and side panels	Vehicle colour	Vehicle colour with chrome trim strips	Vehicle colour with chrome trim strips
Fog lamp surrounds	Black surround	Chrome surround	Chrome surround with two chrome bars
Line badge	Wings without line lettering	ELEGANCE line lettering on the wings	AVANTGARDE line lettering on the wings
Radiator grille	3 louvres, chromed, star on bonnet	3 louvres, chromed, star on bonnet	3 louvres, brilliant silver, central star on radiator grille
Shoulderline trim strip	Matt black	Polished aluminium	Polished aluminium
Tail lights (in conjunction with projection-beam headlamps)	Light meander	Light meander	Dark meander
Wheels	16-inch 7-spoke light-alloy wheels	17-inch 12-spoke light-alloy wheels for C 320 CDI and C 350, 16-inch 12-spoke light-alloy wheels for all other models	17-inch 5-twin-spoke light-alloy wheels
Interior			
Gearshift console	Polyurethane shift lever gaiter, black plastic surround	Leather shift lever gaiter, chrome surround	Leather shift lever gaiter, chrome surround
Instrument cluster	Backplate in black	Backplate in black	Backplate in titanium silver
Seat design	Large panels with horizontal stitching	Thinly spaced vertical stitching	Sporty horizontal stitching
Steering wheel	Polyurethane-foam multifunction steering wheel	Luxury multifunction steering wheel in leather with 4.5-inch display in the instrument cluster	Luxury multifunction steering wheel in leather with 4.5-inch display in the instrument cluster
Trim elements	Piano-lacquer-effect finish	Eucalyptus wood	Aluminium
Upholstery	Brighton fabric	Edinburgh fabric	Liverpool fabric / ARTICO man-made leather



The AMG sports package¹

If you would like to give your C-Class an even sportier character, the optional AMG sports package offers an attractive combination of features: a dynamic AMG front apron, side skirts and a distinctive AMG rear apron as well as 17-inch 6-twin-spoke AMG light-alloy wheels with mixed-size tyres (225/45 at the front and 245/40 at the rear). You can also opt for 18-inch 5-twin-spoke AMG light-



Powerful: AMG rear apron and 17-inch AMG light-alloy wheels

¹Shown here in combination with the AVANTGARDE line

alloy wheels. The sports suspension, which is lowered by 15 mm, actively helps to enhance driving pleasure – as does the speed-sensitive sports steering. And while the perforated front brake discs and brake callipers with “Mercedes-Benz” lettering have a breathtakingly sporty look, they also deliver reassuring deceleration.



Powerful look, powerful effect: the perforated brake discs



Featuring large air intakes and round fog lights with chrome surrounds, the AMG front apron lends the C-Class an athletic look. The powerful AMG rear apron, meanwhile,

along with the side skirts and the high-shine 17-inch 6-twin-spoke AMG light-alloy wheels, gives the dynamic AMG sports package an even keener edge.



Powerful: the AMG front apron



The AMG sports package – interior

The AMG sports package creates a special atmosphere inside the car too: the sports seats provide secure support and, like the rear seats, are upholstered in a Liverpool fabric/ARTICO man-made leather combination. Leather upholstery is available as an option.

Also included in the AMG sports package is a sporty 3-spoke leather steering wheel featuring shift paddles for



Behind the 3-spoke leather steering wheel are shift paddles for manual gear changes (in conjunction with automatic transmission)

gear selection (when fitted in conjunction with an automatic transmission). The look of the instrument cluster is based on the tube-type design found in the C 63 AMG. Brushed stainless-steel sports pedals, black floor mats with AMG lettering, black roof lining and an aluminium-look shift/selector lever are further highlights of the sporty interior.



AMG through and through: the sports pedals in brushed stainless steel



Standard equipment (selection)

 3-point seat belts and head restraints for all seats

 6-speed manual transmission¹

 Adaptive brake lights

 ADAPTIVE BRAKE with ABS, ASR, brake drying function and Hill-Start Assist

 AGILITY CONTROL suspension with selective damping system

 Airbags (front), sidebags (front) and windowbags

 ASSYST service interval indicator

 Audio 20 CD²

 Belt tensioners with belt force limiters, front and outer rear seats

 Brake Assist (BAS)

 Central locking (remote control with selective and global opening)

 Clear-lens fog lamps

 Clear-lens headlamps with projection-beam technology

 Electronic Stability Program ESP®

 Front armrest, with stowage compartment

 Front seats with electrically adjustable height and backrest angle

 Headlamp Assist

 Heated exterior mirrors, electrically adjustable, with aspherically curved glass and clear-lens indicators

 Heated rear window with time relay

 Kneebag for driver (Europe only)

 Multifunction steering wheel with trip computer

 Outside temperature display

 Power windows (4), with one-touch control

 Remote boot-lid release, can be operated via key

 Seat occupancy sensor for front passenger seat

 THERMATIC 2-zone automatic climate control

¹ 7G-TRONIC 7-speed automatic transmission fitted as standard in C 350, C 350 CGI BlueEFFICIENCY, C 63 AMG and 4MATIC models

² Optional extra for C 200 CDI BlueEFFICIENCY



Control panel for 2-zone automatic climate control THERMATIC



Designer key

Ever thought of investing in precious metals?

The light-alloy wheels for the C-Class

The C-Class is equipped with 16-inch 7-spoke light-alloy wheels as standard. The ELEGANCE line features 16 or 17-inch light-alloy wheels as standard, depending on the model. Both have a 12-spoke design. The AVANTGARDE line is

supplied with particularly sporty 17-inch 5-twin-spoke wheels. Both the C 250 CDI BlueEFFICIENCY Prime Edition and the C 350 CGI BlueEFFICIENCY are fitted with 16-inch 7-spoke light-alloy wheels as standard. Other

attractive 16 and 17-inch light-alloy wheels are available as an option.



16-inch 7-spoke light-alloy wheel¹ (standard)



16-inch 12-spoke light-alloy wheel (ELEGANCE)



17-inch 5-twin-spoke light-alloy wheel (AVANTGARDE)



16-inch 7-spoke light-alloy wheel²



16-inch 7-spoke light-alloy wheel²



17-inch 5-spoke light-alloy wheel



17-inch 5-twin-spoke light-alloy wheel



17-inch 7-twin-spoke light-alloy wheel



17-inch multi-spoke light-alloy wheel

¹Standard for C 250 CDI BlueEFFICIENCY Prime Edition

²Standard for C 350 CGI BlueEFFICIENCY

Rounding off the sporty look

AMG light-alloy wheels

Highly exclusive and sensationally sporty – high-sheen 17-inch 6-twin-spoke AMG light-alloy wheels shod with 225/45 tyres at the front and 245/40 tyres at the rear are available in conjunction with the AMG sports package.

High-sheen 18-inch 5-twin-spoke AMG light-alloy wheels with size 225/40 tyres at the front and size 255/35 tyres at the rear are available as an optional extra for all models and in conjunction with the AMG sports package.



17-inch 6-twin-spoke AMG light-alloy wheel



18-inch 5-twin-spoke AMG light-alloy wheel

If designer footwear is your thing ...

incenio designer wheels

The range of Mercedes-Benz accessories for the C-Class features exclusive incenio light-alloy wheels, such as the 18-inch 5-twin-spoke “Pulaha” designer wheel.



18-inch “Pulaha” 5-twin-spoke incenio designer wheel

Even traffic bulletins can be a joy to listen to

The radios, navigation systems and surround sound system

The C-Class provides plenty of listening enjoyment when you're on the move. You can choose between three high-end audio systems, all of which are available as an option.

The Audio 20 CD features a 4.9-inch colour display, a CD player which can also play MP3 files, and Bluetooth functionality. It can also be combined with a 6-CD changer as an option. The Audio 50 APS unit also includes a DVD drive for both audio functions and the integrated DVD navigation system with dynamic route guidance.

The highlight of the on-board entertainment range for the C-Class is COMAND APS. You can find out more about it on page 37.

All audio systems (except Audio 20 without a CD changer) can be combined with the Harman Kardon® Logic 7® surround sound system as an option. A DSP amplifier with Logic 7® technology and a total output of 450 W as well as 12 high-performance loudspeakers ensure great sound quality and a breathtaking surround sound experience, whether you are listening to a stereo or Dolby Digital 5.1 recording (Audio 20 CD offers stereo reproduction only).



Audio 20 with a CD drive



Audio 50 APS radio with a DVD navigation system

Optional extras (selection)	C 200 CDI	C 200 CDI BlueEFFICIENCY	C 220 CDI	C 250 CDI BlueEFFICIENCY	C 320 CDI	C 320 CDI 4MATIC	C 180 KOMPR. BlueEFFICIENCY	C 200 KOMPR.	C 230	C 280	C 280 4MATIC	C 350	C 350 4MATIC	C 350 CGI BlueEFFICIENCY	C 63 AMG
5-speed automatic transmission	●	●	●	-	-	-	●	●	-	-	-	-	-	-	-
7G-TRONIC 7-speed automatic transmission	-	-	-	-	●	□	-	-	●	●	□	□	□	□	□
AMG sports package	●	-	●	●	●	●	●	●	●	●	●	●	●	●	-
Anti-theft alarm system with tow-away protection and interior monitoring	●	●	●	●	●	●	●	●	●	●	●	●	●	●	●
Bi-xenon headlamps	●	●	●	●	●	●	●	●	●	●	●	●	●	●	●
COMAND APS multimedia system with a DVD drive	●	●	●	●	●	●	●	●	●	●	●	●	●	●	●
Cruise control	●	●	●	●	●	□	●	●	●	●	□	□	●	□	□
Dynamic handling package	-	-	●	-	●	-	-	●	●	●	-	●	-	●	-
Folding trailer coupling incl. ESP® trailer stabilisation	●	-	●	●	●	●	●	●	●	●	●	●	●	●	-

● Optional extra □ Standard - Not available



The PARKTRONIC parking aid with visual proximity warning



Rear windscreen roller blind, electric (saloon only)

Optional extras (selection)	C 200 CDI	C 200 CDI BlueEFFICIENCY	C 220 CDI	C 250 CDI BlueEFFICIENCY	C 320 CDI	C 320 CDI 4MATIC	C 180 KOMPR. BlueEFFICIENCY	C 200 KOMPR.	C 230	C 280	C 280 4MATIC	C 350	C 350 4MATIC	C 350 CGI BlueEFFICIENCY	C 63 AMG
Harman Kardon® Logic 7® surround sound system, Dolby Digital 5.1 and stereo, 12 loudspeakers, 450 W	●	●	●	●	●	●	●	●	●	●	●	●	●	●	●
Heated front seats	●	●	●	●	●	●	●	●	●	●	●	●	●	●	●
Heated windscreen washer system	●	●	●	●	●	●	●	●	●	●	●	●	●	●	●
Intelligent Light System with bi-xenon headlamps	●	●	●	●	●	●	●	●	●	●	●	●	●	●	●
Interior and driver's-side exterior mirror automatically dimming, exterior mirrors electrically folding	●	●	●	●	●	●	●	●	●	●	●	●	●	●	●
KEYLESS-GO	●	●	●	●	●	●	●	●	●	●	●	●	●	●	●
Media interface	●	●	●	●	●	●	●	●	●	●	●	●	●	●	●
Memory function for driver's seat, steering column, exterior mirrors	●	●	●	●	●	●	●	●	●	●	●	●	●	●	●

● Optional extra □ Standard - Not available



Intelligent Light System with bi-xenon headlamps



KEYLESS-GO – open the doors and start the engine without even taking the key out of your pocket

Optional extras (selection)	C 200 CDI	C 200 CDI BlueEFFICIENCY	C 220 CDI	C 250 CDI BlueEFFICIENCY	C 320 CDI	C 320 CDI 4MATIC	C 180 KOMPR. BlueEFFICIENCY	C 200 KOMPR.	C 230	C 280	C 280 4MATIC	C 350	C 350 4MATIC	C 350 CGI BlueEFFICIENCY	C 63 AMG
Mounted fire extinguisher	●	●	●	●	●	●	●	●	●	●	●	●	●	●	●
Multicontour front seats	●	●	●	●	●	●	●	●	●	●	●	●	●	●	-
PARKTRONIC	●	●	●	●	●	●	●	●	●	●	●	●	●	●	●
PRE-SAFE® system	●	●	●	●	●	●	●	●	●	●	●	●	●	●	●
Panoramic sliding sunroof with electric roller blinds	●	●	●	●	●	●	●	●	●	●	●	●	●	●	-
Rear windscreen roller blind, electric	●	●	●	●	●	●	●	●	●	●	●	●	●	●	●
Sidebags in rear	●	●	●	●	●	●	●	●	●	●	●	●	●	●	●
Speed-sensitive power steering	●	-	●	●	●	●	●	●	●	●	●	●	●	●	-
THERMOTRONIC 3-zone luxury automatic climate control	●	●	●	●	●	●	●	●	●	●	●	●	●	●	●
Through-loading facility, folding rear seats ²	●	●	●	●	●	●	●	●	●	●	●	●	●	●	□
Tilting / sliding glass sunroof	●	●	●	●	●	●	●	●	●	●	●	●	●	●	● ²

● Optional extra □ Standard - Not available ¹ Standard for C 63 AMG Estate ² Standard for C-Class Estate



Rear control panel for 3-zone luxury automatic climate control THERMOTRONIC



Rear armrest with cup holders

Standard equipment (selection)

 3-point seat belts and head restraints for all seats

 6-speed manual transmission¹

 Adaptive brake lights

 ADAPTIVE BRAKE with ABS, ASR, brake drying function and Hill-Start Assist

 AGILITY CONTROL steering

 AGILITY CONTROL suspension with selective damping system

 Airbags (front), sidebags (front) and windowbags

 Anchoring rings with chrome finish

 ASSYST service interval indicator

 Audio 20 CD

 Belt tensioners with belt force limiters, front and outer rear seats

 Brake Assist (BAS)

 Clear-lens fog lamps

 Clear-lens headlamps with projection-beam technology

 Electronic Stability Program ESP®

 Front and rear armrests with stowage facility

 Front seats with electrically adjustable height and backrest angle

 Headlamp Assist

 Kneebag for driver (Europe only)

 Multifunction steering wheel with trip computer

 Outside temperature display

 Power windows (4), with one-touch control

 Side luggage nets

 THERMATIC 2-zone automatic climate control

¹7G-TRONIC 7-speed automatic transmission fitted as standard in C 320 CDI 4MATIC, C 350 and C 63 AMG



Integrated child seat (optional extra)



Sunblinds on rear doors (optional extra)

Optional extras (selection)	C 200 CDI	C 220 CDI	C 320 CDI	C 320 CDI 4MATIC	C 180 KOMPR. BlueEFFICIENCY	C 200 KOMPR.	C 230	C 280	C 350	C 63 AMG
5-speed automatic transmission	●	●	-	-	●	●	-	-	-	-
7G-TRONIC 7-speed automatic transmission	-	-	●	□	-	-	●	●	□	□
AMG sports package	●	●	●	●	●	●	●	●	●	-
COMAND APS multimedia system with a DVD drive	●	●	●	●	●	●	●	●	●	●
Dark-tinted side and rear windows	●	●	●	●	●	●	●	●	●	●
Dynamic handling package	-	●	●	-	-	●	●	●	●	-
EASY-PACK load-securing kit	●	●	●	●	●	●	●	●	●	●
EASY-PACK tailgate	●	●	●	●	●	●	●	●	●	●
Folding trailer coupling incl. ESP® trailer stabilisation	●	●	●	●	●	●	●	●	●	-
Panoramic sliding sunroof with electric roller blinds	●	●	●	●	●	●	●	●	●	-
PRE-SAFE® system	●	●	●	●	●	●	●	●	●	●
Self-levelling suspension	●	●	●	●	●	●	●	●	●	-
Sunblinds on rear doors	●	●	●	●	●	●	●	●	●	●

● Optional extra □ Standard - Not available



Panoramic sliding sunroof (optional extra)



EASY-PACK tailgate (optional extra)



As personal as your own handwriting

Individualise your vehicle in line
with your own tastes with the designo range

How can you personalise a Mercedes C-Class so that it truly becomes your Mercedes? The answer is designo, a range of carefully selected materials which allows you to turn your vehicle into a unique masterpiece. With superb leather appointments, perfectly colour-coordinated fabric roof lining and matching velour floor mats. As well as having instant appeal, the remarkable quality which characterises the look and feel of even the smallest details of the designo range of appointments is a source of lasting pleasure.

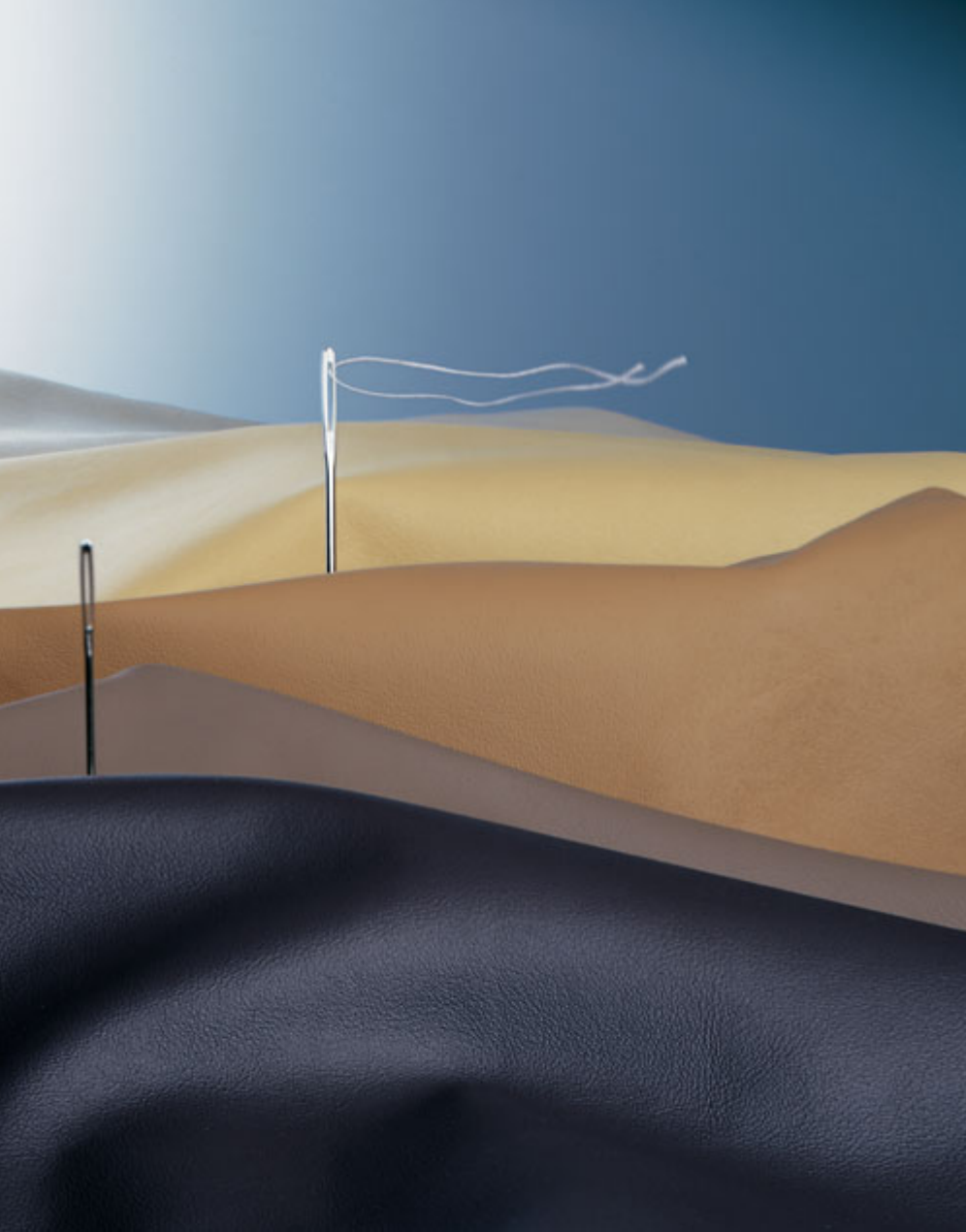

As unique as you are

The designo leather appointments

designo is synonymous with outstanding craftsmanship. Like that of the experienced upholsterers, for example, who painstakingly turn hand-picked hides into beautiful leather appointments. Two of these sets of exclusive designo leather appointments are available for the C-Class Saloon and Estate.

You can choose between the leather colours designo porcelain and designo sand. The designo seating has a characteristic two-tone design with the seat centre panels in the chosen designo colour and the side bolsters in black.



Two-tone: designo leather appointments for the Mercedes C-Class

In addition, high-quality designo metal badges are set into the backrests of the front seats. The interior appointments are completed by the black fabric roof lining and velour floor mats with a designo leather surround in black.

The designo leather appointments are available only in conjunction with the ELEGANCE and AVANTGARDE lines and cannot be specified for the C 63 AMG.



The hallmark of quality and meticulous workmanship: the designo badge





Those special extras

Genuine Mercedes-Benz accessories for the C-Class Saloon

From attractive to practical – there's a whole selection of extras to choose from in the Mercedes-Benz accessories range.

Take the genuine styling products, for example. The line-up for the C-Class includes front apron spoiler lips, a rear apron, rear/roof spoilers and incenio designer wheels.



Luxury at your fingertips: the wood/leather steering wheel

The range of accessories has plenty of other extras in store, too, including carrier systems, wood/leather steering wheels, and cup holders. For details of the full range, please see our special C-Class accessories brochure, or contact your Mercedes-Benz dealer who will be happy to help you.



One less reason to break your journey: the cup holder for the centre console



Perfect, right down to the smallest detail

Practical and versatile: genuine accessories for the C-Class Estate

Practicality and attractiveness are defining characteristics of the C-Class Estate. So it's good to know that there is a range of genuine accessories which allow you to enhance it to meet your specific requirements without compromising these key attributes. Suppose you like skiing, for example. A Mercedes-Benz roof box might be just what you need. As well as offering good aerodynamics and very attractive styling, it's also extremely practical and versatile. If cycling's

your thing, by contrast, how about the New Alustyle bicycle rack? You'll find loading your C-Class is also particularly easy and convenient with our load compartment products. What's more, they ensure the high standards of travelling safety which are synonymous with Mercedes-Benz. The shallow load compartment tub, for example, not only allows items to be carried hygienically but also fits the load compartment perfectly, has a non-slip surface and

is food-safe. The concertina-type folding bag comprises two bags made from tough, washable nylon fabric. Each bag has two large compartments and two handles which make it easy to remove and carry.

For details of other useful items, please see the C-Class accessories brochure which is available separately, or contact your Mercedes-Benz dealer.



Alustyle basic carrier bars with New Alustyle bicycle rack



Concertina-type folding bag



Load compartment tub



Irresistibly attractive. And extremely resistant

The extra-scratch-resistant clearcoat of the C-Class

Stars are meant to shine, and if ours seem to shine brighter, it's because we have followed the Mercedes tradition of pioneering new technologies and have developed one of the best clearcoats available in the automotive market. Thanks to this innovative Mercedes-Benz paint system, our vehicles now make an even more impressive visual statement which is also reflected in their even higher value retention. This clearcoat developed by Mercedes-Benz is more resistant than conventional clearcoats by virtue of its particularly dense molecular structure. It also produces

a more lasting and noticeably more intense sheen. Whether you choose a metallic or non-metallic paint finish, this more scratch-resistant clearcoat is less sensitive to weathering and environmental influences, rain and snow, sunlight and temperature fluctuations. It is also more resistant to chemical attack and physical wear and tear, such as that caused by automatic car washes. You can rest assured that your new Mercedes will continue to shine elegantly throughout its long life.

The C-Class paintwork puts the finishing touch to the carefully crafted Mercedes-Benz corrosion protection system, which includes zinc phosphating and electrophoretic dip priming stages for long-lasting protection. Furthermore, Mercedes-Benz makes extensive use of eco-friendly water-based paints.

Non-metallic paints



040 black



590 fire opal



650 calcite white

Metallic paints



197 obsidian black



300 periclase green



359 tanzanite blue

Special paint

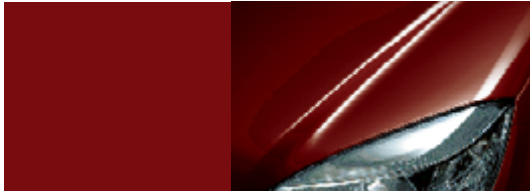

544 carneol red

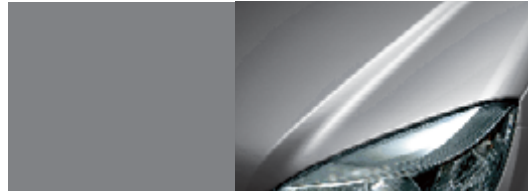

775 iridium silver

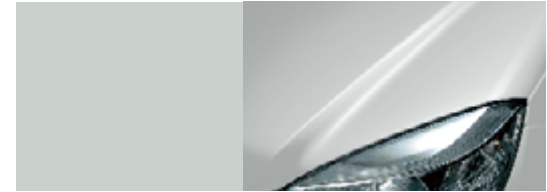

799 diamond white BRIGHT¹



723 cubanite silver

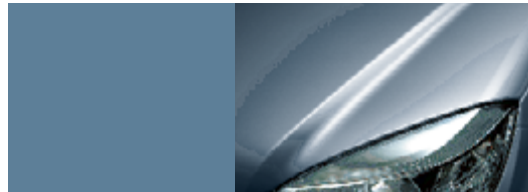

792 palladium silver

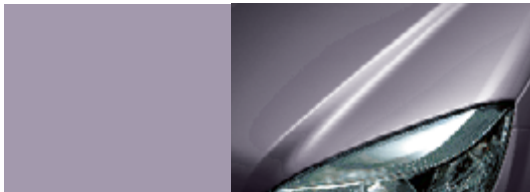

755 tenorite grey



798 sanidine beige

¹Only available for C 250 CDI BlueEFFICIENCY Prime Edition with AVANTGARDE line

The seats of a Mercedes-Benz offer an extremely high degree of comfort thanks to the special way in which the seat cushions are sprung and the use of separate foam elements for the centre panel of the seat cushion and the sides. The combination of the seat cushion spring set-up, which is precisely tuned to the vehicle, and the selection of the appropriate degree of cushion density results in exceptional springing and damping characteristics. You can create an ideal seating environment which reflects your own preferences by choosing from our range of fabric and/or leather upholstery. The fabric patterns have been developed to complement and harmonise with the different design and equipment lines of the C-Class.

Standard

Brighton fabric



001 black



018 alpaca grey

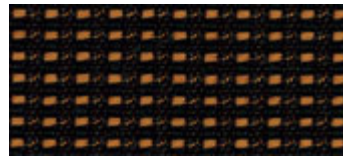

055 black/beige



057 black/red

ELEGANCE

Edinburgh fabric

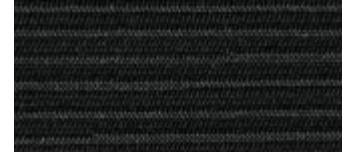

401 black



415 almond beige



418 alpaca grey

AVANTGARDE and AMG sports package

Liverpool fabric/
ARTICO man-made leather

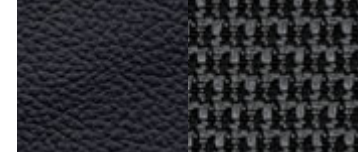

701 black

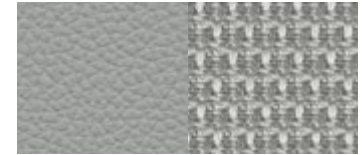

718 alpaca grey

Standard and ELEGANCE

ARTICO man-made leather

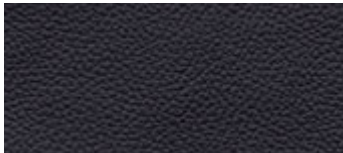

101 black

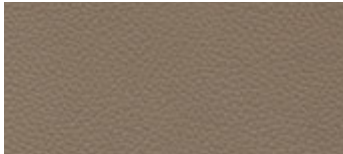

115 almond beige
(for ELEGANCE only)



118 alpaca grey

ELEGANCE, AVANTGARDE and AMG sports package¹

Leather

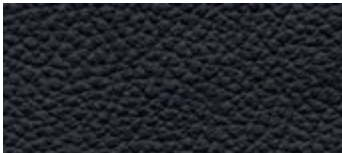

201 black

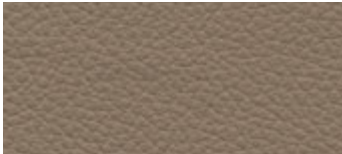

215 almond beige
(for ELEGANCE only)

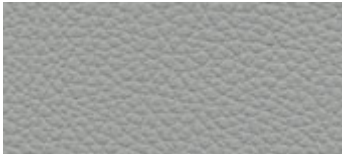

218 alpaca grey

AVANTGARDE and AMG sports package¹

Leather

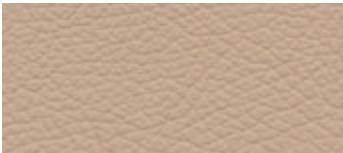

205 black/sahara beige

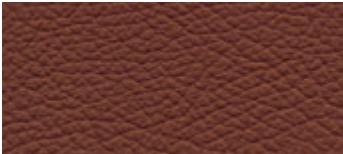

207 black/cognac brown

designo

Leather²



X77 sand

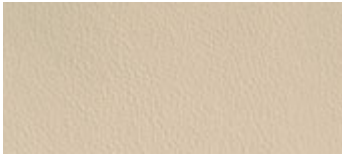

X87 porcelain

¹Leather appointments only in conjunction with ELEGANCE and AVANTGARDE

²Only in conjunction with the ELEGANCE or AVANTGARDE design and equipment lines. designo leather appointments are not available for the C 63 AMG

Many hours of care and attention are lavished on every Mercedes-Benz. The wood trim elements are just one example of the craftsmanship involved: it takes around three weeks to turn this natural product into a perfectly finished Mercedes component.

Special computer-controlled planing machines slice the thinnest of veneers from the wood. The ones whose colour and grain characteristics match best are then used to create a complete veneer. This process involves placing the individual layers on thin substrate elements with intermediate layers of aluminium and glue sheets to ensure strength and durability. Up to 100 of these layers are applied by hand to create a trim strip. Take a close look at your C-Class and you will see how much care has gone into every detail.

Standard

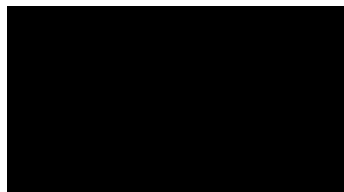

Piano-lacquer-effect finish



Burr walnut (optional extra)

ELEGANCE



Eucalyptus



Burr walnut (optional extra)

AVANTGARDE



Aluminium



Black bird's-eye maple (optional extra)

	NON-METALLIC PAINTS			METALLIC PAINTS									
	black	fire opal	calcite white	obsidian black	periclase green	tanzanite blue	carneol red	cubanite silver	tenorite grey	iridium silver	palladium silver	sandrine beige	diamond white BRIGHT
Brighton fabric (standard)													
black	●	●	●	●	●	●	●	●	●	●	●	●	●
alpaca grey	●	○	●	●	○	●	●	○	●	●	○	△	●
black/beige	●	△	△	●	△	△	○	○	△	△	△	●	△
black/red	●	○	●	●	△	○	●	○	△	●	△	△	●
Edinburgh fabric (ELEGANCE)													
black	●	●	●	●	●	●	●	●	●	●	●	●	●
almond beige	●	○	○	●	●	○	●	△	△	△	△	●	○
alpaca grey	●	○	●	●	○	●	●	○	●	●	○	△	●
Liverpool fabric/ARTICO man-made leather (AVANTGARDE and AMG sports package)													
black	●	●	●	●	●	●	●	●	●	●	●	●	●
alpaca grey	●	○	●	●	○	●	●	○	●	●	○	△	●
ARTICO man-made leather (standard, ELEGANCE)													
black	●	●	●	●	●	●	●	●	●	●	●	●	●
almond beige	●	○	○	●	●	○	●	△	△	△	△	●	○
alpaca grey	●	○	●	●	○	●	●	○	●	●	○	△	●
Leather (ELEGANCE, AVANTGARDE and AMG sports package)													
black	●	●	●	●	●	●	●	●	●	●	●	●	●
almond beige	●	○	○	●	●	○	●	△	△	△	△	●	○
alpaca grey	●	○	●	●	○	●	●	○	●	●	○	△	●
Leather (AVANTGARDE)													
black/sahara beige	●	○	○	●	○	●	●	○	○	△	△	●	○
black/cognac brown	●	△	●	●	△	○	△	●	△	●	○	○	●

● Recommended ○ Possible △ Not recommended

	C 200 CDI	C 200 CDI BlueEFFICIENCY	C 220 CDI	C 250 CDI BlueEFFICIENCY	C 320 CDI	C 320 CDI 4MATIC
No. and arrangement of cylinders	4 / in-line	4 / in-line	4 / in-line	4 / in-line	6 / V	6 / V
Total displacement (cc)	2148	2148	2148	2143	2987	2987
Rated output ¹ (kW at rpm)	100/3800	100/3800	125/3800	150/4200	165/3800	165/3800
Rated torque ¹ (Nm at rpm)	270/1600–3000	270/1600–3400	400/2000	500/1600–1800	510/1600–2800	510/1600–2800
Compression ratio	17.5	17.5	17.5	16.2	17.7	17.7
Acceleration from 0 to 100 km/h (s) (automatic transmission)	10.4 (10.2)	10.4 –	8.5 (8.4)	7.0 –	7.7 (6.9)	– (6.9)
Top speed, approx. (km/h) (automatic transmission)	215 (213)	220 –	229 (227)	250 ² –	250 ² (250) ²	– (250) ²
Tyre size front	195/60 R 16	195/60 R 16	205/55 R 16	205/55 R 16	225/45 R 17	225/45 R 17
rear	195/60 R 16	195/60 R 16	205/55 R 16	205/55 R 16	225/45 R 17	225/45 R 17
Fuel	Diesel	Diesel	Diesel	Diesel	Diesel	Diesel
Fuel consumption ³ (l/100 km)						
urban (automatic transmission)	7.7–8.2 (9.0–9.2)	6.7–6.9	7.9–8.2 (9.1–9.2)	7.1–7.4	9.2–9.5 (10.0–10.3)	– (10.1–10.5)
extra-urban (automatic transmission)	4.5–4.9 (5.0–5.3)	4.1–4.5	4.7–4.9 (5.1–5.3)	4.2–4.7	5.5–5.8 (5.9–6.2)	– (6.1–6.6)
combined (automatic transmission)	5.7–6.1 (6.5–6.7)	5.1–5.4	5.9–6.1 (6.6–6.7)	5.2–5.7	6.9–7.2 (7.3–7.6)	– (7.6–8.0)
CO ₂ emissions ³ (g/km) combined (automatic transmission)	149–160 (171–177)	133–141 –	156–160 (173–177)	138–150 –	182–191 (193–201)	– (200–211)
Tank capacity (l)/incl. reserve, approx.	66/8	59/8	66/8	66/8	66/8	66/8
Load capacity (l)	475	475	475	475	475	475
Turning circle (m)	10.84	10.84	10.84	10.84	10.84	10.84
Kerb weight ⁴ (kg) (automatic transmission)	1560 (1575)	1505	1585 (1605)	1645	1700 (1700)	– (1760)
Permissible gross vehicle weight (kg) (automatic transmission)	2045 (2060)	1990 –	2070 (2090)	2130 –	2185 (2185)	– (2245)

¹ Figures according to Directive 80/1269/EEC in the currently applicable version

² Electronically governed

C 180 KOMPRESSOR BlueEFFICIENCY	C 200 KOMPRESSOR	C 230	C 280	C 280 4MATIC	C 350	C 350 4MATIC	C 350 CGI BlueEFFICIENCY	C 63 AMG
4/in-line	4/in-line	6/V	6/V	6/V	6/V	6/V	6/V	8/V
1597	1796	2496	2996	2996	3498	3498	3498	6208
115/5200	135/5500	150/6100	170/6000	170/6000	200/6000	200/6000	215/6400	336/6800
230/3000-4500	250/2800-5000	245/2900-5500	300/2500-5000	300/2500-5000	350/2400-5000	350/2400-5000	365/3000-5100	600/5000
9.3	8.5	11.4	11.3	11.3	10.7	10.7	12.2	11.3
9.5 (9.9)	8.6 (8.8)	8.4 (8.6)	7.3 (7.2)	- (7.2)	- (6.4)	- (6.4)	- (6.2)	- (4.5)
230 (223)	235 (230)	240 (233)	250 ² (246)	- (246)	- (250) ²	- (250) ²	- (250) ²	- (250) ²
195/60 R 16	205/55 R 16	205/55 R 16	205/55 R 16	205/55 R 16	225/45 R 17	225/45 R 17	205/55 R 16	235/40 R 18
195/60 R 16	205/55 R 16	205/55 R 16	205/55 R 16	205/55 R 16	225/45 R 17	225/45 R 17	205/55 R 16	255/35 R 18
Premium	Premium	Premium	Premium	Premium	Premium	Premium	Premium	Super Plus
9.5-9.9 (10.1-10.5)	10.5-10.7 (11.0-11.2)	13.3-13.5 (13.1-13.3)	13.4-13.6 (13.3-13.5)	- (13.4-13.6)	- (13.9-14.2)	- (14.5)	- (12.1-12.8)	- (20.9)
5.1-5.7 (5.4-6.0)	5.8-6.0 (6.1-6.3)	6.7-6.9 (6.8-7.0)	6.8-7.0 (6.9-7.1)	- (7.2-7.4)	- (7.3-7.6)	- (7.5)	- (6.1-6.7)	- (9.2)
6.7-7.3 (7.1-7.7)	7.6-7.8 (7.9-8.1)	9.1-9.3 (9.1-9.3)	9.2-9.4 (9.2-9.4)	- (9.4-9.6)	- (9.7-10.0)	- (10.0)	- (8.3-8.9)	- (13.4)
159-173 (169-183)	180-185 (187-192)	216-221 (217-222)	220-225 (219-224)	- (224-229)	- (232-239)	- (239)	- (198-212)	- (319)
66/8	66/8	66/8	66/8	66/8	66/8	66/8	66/8	66/14
475	475	475	475	475	475	475	475	475
10.84	10.84	10.84	10.84	10.84	10.84	10.84	10.84	11.75
1480 (1495)	1490 (1505)	1540 (1560)	1555 (1575)	- (1635)	- (1610)	- (1670)	- (1615)	- (1730)
1965 (1980)	1975 (1990)	2025 (2045)	2040 (2060)	- (2120)	- (2095)	- (2155)	- (2100)	- (2170)

³ The figures shown were obtained in accordance with the prescribed measuring process (Directive 80/1268/EEC in the currently applicable version).

The figures are not based on an individual model and do not constitute part of the product offer; they are provided solely for purposes of comparison between different vehicle models

⁴ Figures according to Directive 92/21/EC, as amended by 95/48/EC (kerb weight with fuel tank 90% full, driver, 68 kg, and luggage, 7 kg) for standard-specification vehicles.

Optional extras and accessories will generally increase this figure and reduce the payload capacity accordingly

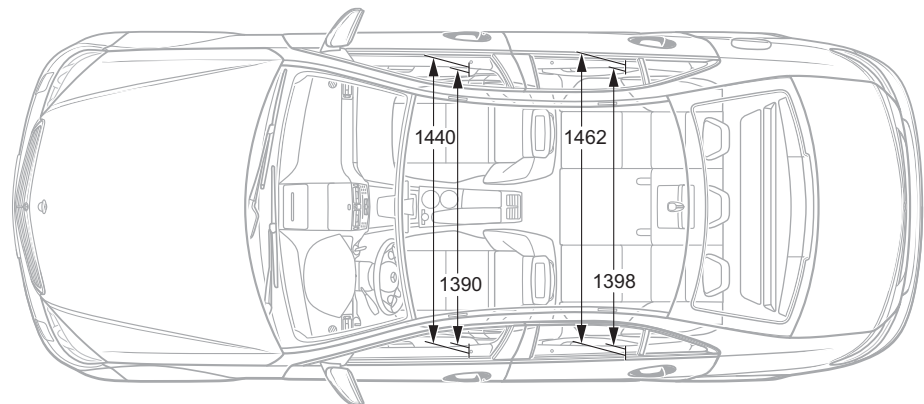
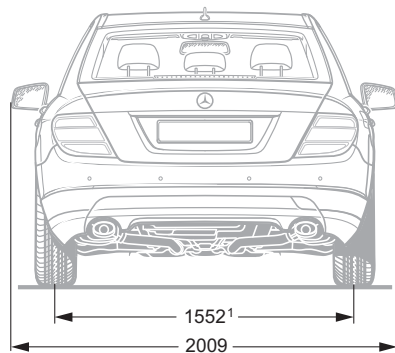
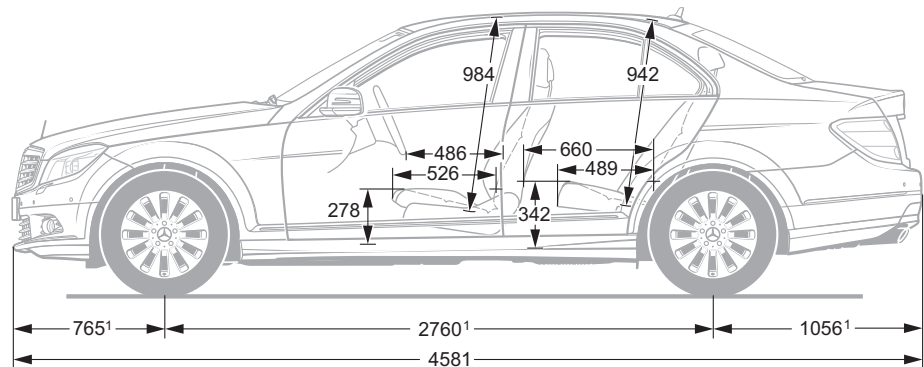
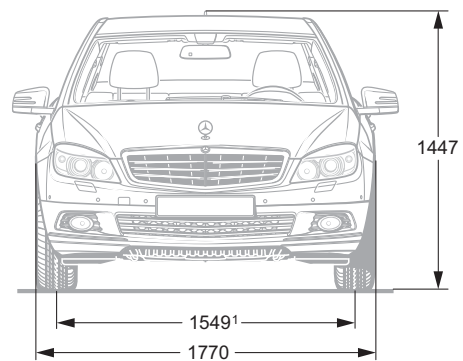

All measurements in millimetres. The dimensions shown are mean values and apply to standard-specification, unladen vehicles

¹ Carrying 3 people, each weighing 68 kg



	C 200 CDI	C 220 CDI	C 320 CDI	C 320 CDI 4MATIC
No. and arrangement of cylinders	4/in-line	4/in-line	6/V	6/V
Total displacement (cc)	2148	2148	2987	2987
Rated output ¹ (kW at rpm)	100/3800	125/3800	165/3800	165/3800
Rated torque ¹ (Nm at rpm)	270/1600-3000	400/2000	510/1600-2800	510/1600-2800
Compression ratio	17.5	17.5	17.7	17.7
Acceleration from 0 to 100 km/h (s) (automatic transmission)	10.8 (10.6)	8.9 (8.8)	7.9 (7.1)	- (7.1)
Top speed, approx. (km/h) (automatic transmission)	208 (204)	224 (220)	245 (244)	- (244)
Tyre size front	205/55 R 16	205/55 R 16	225/45 R 17	225/45 R 17
rear	205/55 R 16	205/55 R 16	225/45 R 17	225/45 R 17
Fuel	Diesel	Diesel	Diesel	Diesel
Fuel consumption ³ (l/100 km)				
urban (automatic transmission)	7.7-8.1 (8.9-9.0)	7.8-8.1 (9.2)	9.7-10.0 (10.2-10.5)	- (9.9-10.7)
extra-urban (automatic transmission)	4.8-5.0 (5.2-5.3)	4.8-5.0 (5.3-5.5)	5.9-6.2 (6.2-6.5)	- (6.3-6.6)
combined (automatic transmission)	5.9-6.1 (6.6-6.7)	5.9-6.1 (6.8)	7.1-7.4 (7.5-7.8)	- (7.7-8.1)
CO ₂ emissions ³ (g/km), combined (automatic transmission)	154-161 (175-176)	156-161 (178-180)	188-198 (199-209)	- (205-215)
Tank capacity (l)/incl. reserve, approx.	66/8	66/8	66/8	66/8
Load capacity (l)	485	485	485	485
Turning circle (m)	10.84	10.84	10.84	10.84
Kerb weight ⁴ (kg) (automatic transmission)	1605 (1615)	1630 (1650)	1750 (1750)	- (1810)
Permissible gross vehicle weight (kg) (automatic transmission)	2135 (2145)	2160 (2180)	2280 (2280)	- (2340)

¹ Figures according to Directive 80/1269/EEC in the currently applicable version ² Electronically governed ³ The figures shown were obtained in accordance with the prescribed measuring process (Directive 80/1268/EEC in the currently applicable version). The figures are not based on an individual model and do not constitute part of the product offer; they are provided solely for purposes of comparison between different vehicle models

C 180 KOMPRESSOR BlueEFFICIENCY	C 200 KOMPRESSOR	C 230	C 280	C 350	C 63 AMG
4/in-line	4/in-line	6/V	6/V	6/V	8/V
1597	1796	2496	2996	3498	6208
115/5200	135/5500	150/6100	170/6000	200/6000	336/6800
230/3000-4500	250/2800-5000	245/2900-5500	300/2500-5000	350/2400-5000	600/5000
9.3	8.5	11.4	11.3	10.7	11.3
9.8 (10.2)	8.8 (9.0)	8.6 (8.9)	7.5 (7.5)	- (6.5)	- (4.6)
223 (218)	228 (225)	232 (227)	242 (240)	- (250) ²	- (250) ²
205/55 R 16 205/55 R 16	205/55 R 16 205/55 R 16	205/55 R 16 205/55 R 16	205/55 R 16 205/55 R 16	225/45 R 17 225/45 R 17	235/40 R 18 255/35 R 18
Premium	Premium	Premium	Premium	Premium	Super Plus
9.4-9.8 (10.4-10.8)	10.7-10.9 (11.2-11.4)	13.4-13.6 (13.4-13.6)	13.6-13.8 (13.4-13.6)	- (14.5-14.8)	- (21.1)
5.5-6.0 (5.8-6.2)	6.0-6.2 (6.4-6.6)	6.9-7.1 (6.9-7.1)	7.0-7.2 (7.1-7.3)	- (7.3-7.6)	- (9.5)
6.9-7.4 (7.5-7.9)	7.8-8.0 (8.1-8.3)	9.3-9.5 (9.3-9.5)	9.4-9.6 (9.4-9.6)	- (9.9-10.2)	- (13.7)
164-176 (179-187)	184-189 (193-198)	221-226 (221-226)	224-229 (224-229)	- (235-242)	- (326)
66/8	66/8	66/8	66/8	66/8	66/14
485	485	485	485	485	485
10.84	10.84	10.84	10.84	10.84	11.75
1530 (1545)	1540 (1555)	1585 (1605)	1600 (1615)	- (1655)	- (1795)
2060 (2065)	2070 (2085)	2115 (2135)	2130 (2145)	- (2185)	- (2275)

⁴ Figures according to Directive 92/21/EC, as amended by 95/48/EC (kerb weight with fuel tank 90 % full, driver, 68 kg, and luggage, 7 kg) for standard-specification vehicles. Optional extras and accessories will generally increase this figure and reduce the payload capacity accordingly

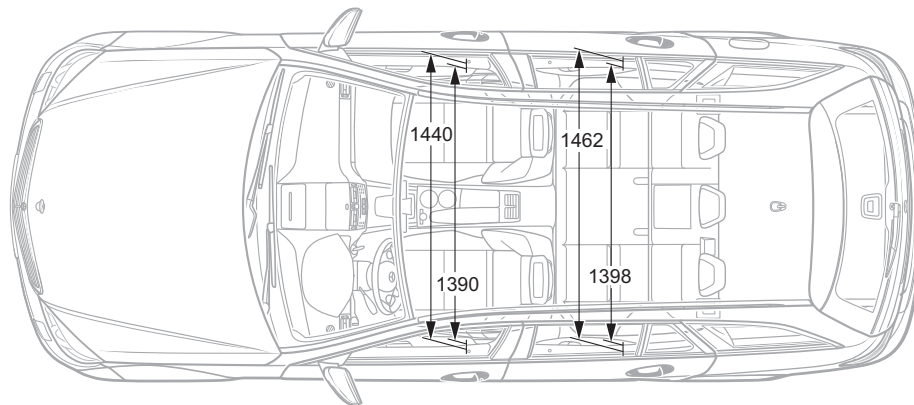
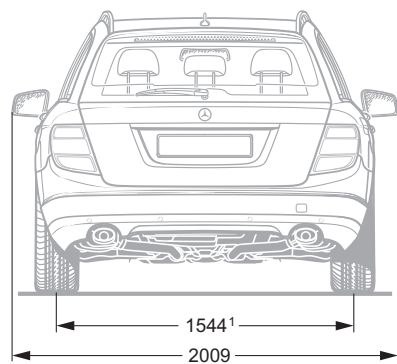
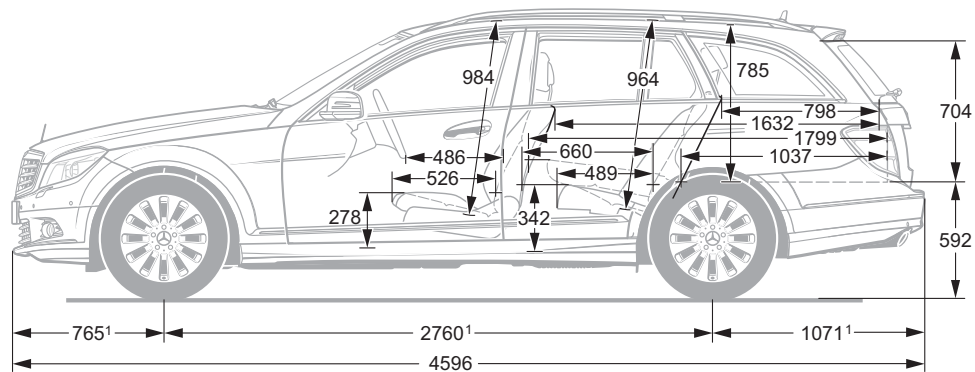
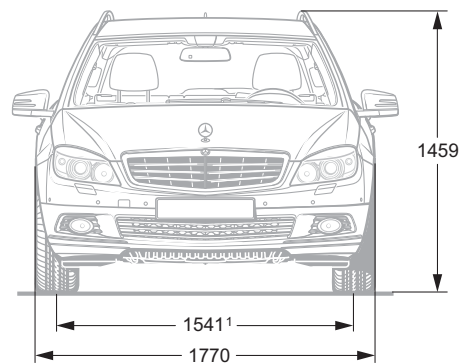

All measurements in millimetres. The dimensions shown are mean values and apply to standard-specification, unladen vehicles

¹Carrying 3 people, each weighing 68 kg



Anyone opting for a Mercedes buys far more than just a car

Comprehensive service offered by Mercedes-Benz

Mercedes-Benz for you

It all started in Berlin at the end of 2000: the concept of the car dealership was reinvented with the opening of the first Mercedes-Benz Centre. Featuring the entire Mercedes-Benz model line-up as well as the accessories range, brand merchandise and an attractive programme of events, the Centres offer a welcoming environment in which to experience the brand at first hand.

But it's not just in major cities that you can experience the legendary Mercedes-Benz brand and service. A close-knit network of company-owned branches and authorised dealers ensures that you are never far from the wide range of services, the comprehensive customer care and the high quality which you expect from Mercedes-Benz. And you can count on their support at every stage – before you buy your Mercedes, during the purchase process and, most importantly, for a long time afterwards, too.

Mercedes-Benz Museum

More than 120 years of automotive history in one place – this is what awaits you at the Mercedes-Benz Museum in Stuttgart. Experience the unique excitement first hand, and embark upon a thrilling journey through time. Housed inside an architecturally impressive building, over 1500 exhibits on nine levels give you an insight into the unique tradition and powers of innovation of the Mercedes-Benz brand. Plus you can see the world's first two automobiles in the shape of the Benz Patent-Motorwagen (motor car) and the Daimler motorised carriage – both from the year 1886. Two linked circuits take you from the beginnings of the automobile, past a series of unforgettable classics, through 100 years of motor-racing history and, finally, on to a glimpse of what the future holds – all in an area covering a total of 16,500 square meters. Enjoy the unique brand experience. We look forward to your visit.

MercedesCard

Your ticket to the Mercedes-Benz experience: the quarterly MercedesCard ARGENTUM journal offers you an exclusive selection of exciting events starring the Mercedes-Benz brand. In addition, the Mercedes magazine is packed with gripping and inspiring articles and reports. The MercedesCard has many other functions: as a VISA credit card, it is an accepted form of payment worldwide – with no annual fee if you complete a questionnaire every year. In addition, it offers further benefits to put your mind at ease, such as the Mercedes-Benz insurance package, at no extra charge, and the exclusively compiled MercedesCard insurance package at a preferential rate. For further information about this offer, available exclusively to Mercedes-Benz drivers, visit www.mercedes-benz.de/mercedescard¹

¹Information about the MercedesCard in Austria and Switzerland can be found on the Mercedes-Benz websites for these countries

Mercedes-Benz Service24h

The feel-good factor, which kicks in when you sit behind the wheel of your new Mercedes for the first time, is further enhanced by the knowledge that Mercedes-Benz Service24h is there for you around the clock – 365 days a year. Experience shows that your Mercedes model is extremely unlikely to suffer a technical problem or breakdown. And even if the unthinkable happens, you can always count on us, wherever you are in Europe. Just call our Service Hotline on 00800 1 777 7777² at any time. One of our specialists will take your call. And the newly integrated “Mercedes-Benz Contact” telematics service ensures even better customer service. That’s because Mercedes-Benz Contact³ allows you to contact the Mercedes-Benz Customer Centre directly at the push of a button. Mercedes-Benz Contact is the very first menu entry in your audio system’s phone book. The difference with this service is that all the relevant vehicle and position data can be sent to the

Customer Centre automatically. So the member of staff dealing with your call already has all the necessary information to hand. All of which ensures rapid reaction times, personalised service and fast on-the-spot assistance.

Mercedes-Benz Bank

If you have already chosen your dream car and want to remain financially flexible, the Mercedes-Benz Bank should be your next port of call. We are your one-stop shop for leasing, financing, insurance and service packages. By way of example, our “Private Leasing plus” scheme is a complete package comprising leasing, insurance and a purchase option, while our “Plus3” finance package combines low rates with high flexibility. That’s because, at the end of the contract, you decide yourself whether to keep your car, sell it or return it to us for a guaranteed price. We also offer an attractive range of investment products, including instant-access savings accounts, fixed-interest products and investment funds. For further information, please call us on 01803/32 22 65⁴ or visit us at: www.mercedes-benz-bank.de

² Freephone number, mobile-phone rates may vary

³ Only in conjunction with a factory-fitted radio and switched-on mobile phone. For the cost of a call to the landline network

⁴ 9 ct./min from Deutsche Telekom landlines, mobile-phone rates may vary



Time for another enriching experience

A Mercedes-Benz is most at home on the road. This is the only way to experience the effortlessly superior driving feel that lends every model its inimitable class. Feel the power of the engine as it propels the car forwards. Marvel at the precise steering, designed to really put you in the mood for driving. And experience what true comfort really feels like. The unique feeling of driving a Mercedes cannot be put into words, however. Which is why we'd like to invite you to take a test drive. Your Mercedes-Benz dealer will be happy to make all the necessary arrangements for you. Simply visit www.mercedes-benz.com to locate the nearest Mercedes-Benz dealer in your country or region. We look forward to seeing you.

The website also offers an interactive tour, enabling you to take a closer look at your desired model. This simulation is the ideal way to acquaint yourself with your dream car. You can view key functions in detail, gain an insight into the car's inner workings or look at the benefits of each model. For further details, visit www.mercedes-benz.de/owners-manual

Now your mobile phone acts as a gateway to the whole Mercedes-Benz world. In addition to an overview of all passenger car models, there are insights into the entire brand world, not to mention a wealth of entertainment offers and direct links to a range of services at www.mercedes.mobi

Take-back of end-of-life vehicles. Coming full circle. At the end of its long life, you can return your C-Class to us for environment-friendly disposal in accordance with the EC End-Of-Life Vehicle Directive¹. But that day lies a long way off.

¹ Applies in accordance with national regulations to vehicles up to 3.5 tonnes gross weight. Mercedes-Benz passenger cars have met the statutory regulations governing the suitability of their design for reuse and recycling for a number of years now. A network of vehicle take-back depots and dismantlers has been established which will process your vehicle in an environment-friendly manner. The ways in which both vehicles and parts can be recovered are subject to ongoing development and improvement. Consequently, the C-Class will be able to comply with any future increases in the recycling quota within the stipulated time limits. For further information please call 00800 1 777 7777

Please note: changes may have been made to the product since this publication went to press (15.08.2008). The manufacturer reserves the right to make changes to the design, form, colour and specification during the delivery period, provided these changes, while taking into account the interests of the vendor, can be deemed reasonable with respect to the purchaser. Where the vendor or the manufacturer uses symbols or numbers to describe an order or the subject of an order, no rights may be derived solely from these. The illustrations may show accessories and items of optional equipment which are not part of standard specification. Colours may differ slightly from those shown in the brochure, owing to the limitations of the printing process. This publication is distributed internationally. Information concerning legislative, legal or fiscal regulations and their effects is only valid for the Federal Republic of Germany at the time this publication went to press. For current and more specific information in relation to the regulations applicable in other countries and their effects, please contact your nearest authorised Mercedes-Benz Passenger Car Dealer. www.mercedes-benz.com