



This Brochure is prepared by Daimler AG and it predominantly reflects the capabilities and performance of vehicles sold in Europe. Some characteristics, capabilities, performance features and optional extras (e.g. towing systems) may not be available or may not apply in Australia or under Australian conditions. The information in this Brochure is therefore indicative, illustrative and provided only for guidance and should not be relied on. To obtain current and accurate information on a vehicle and any options applicable to Australia, contact your local authorised Mercedes-Benz dealer.

Mercedes-Benz



Mercedes-Benz

The CLC-Class

“Our philosophy is very simple. We give our best for people who expect the best.”

Dr Dieter Zetsche

Contents

The CLC-Class	3	My CLC-Class	38
Design	4	Equipment	40
		Sports package	40
Agility	12	Equipment packages	44
TrueBlueSolutions	14	Standard equipment	46
Diesel engines	16	Optional extras	48
Petrol engines	20	Light-alloy wheels	50
Transmissions	22		
Chassis and steering	24	Genuine accessories	52
Safety	26	Colours and materials	54
Active safety	26	Paintwork	54
Passive safety	28	Upholstery, leather and trim elements	56
		Combination options	57
Comfort	30	Technical details	58
Interior	30	Technical data	58
Seating comfort	32	Dimensions	60
Spaciousness	34		
Sound	36		
		Service and test drive	62

An exceptional form. For a fast-moving lifestyle

The CLC Sports Coupé

Images on paper can never do justice to the outstanding agility of the Mercedes-Benz sports coupé. But it could soon be right in front of you on the road. Expressive styling

and visible dynamism appeal to the heart and the mind in equal measure. And ensure that the CLC will move you even when you are not moving the CLC.

Expressive design. Intense character

It gives you driving pleasure and ride comfort. It takes away any risk of boredom. It all starts the moment you set eyes on the CLC. The design is a modern take on the classic Mercedes-Benz coupé tradition. Convex and concave surfaces intermingle with dynamic lines to create a compact form and give the body its classic wedge shape - rising dynamically all the way up to the seemingly weightless rear end. Sporty touches here include distinctive two-tone lights and a diffuser-style bumper.

The expressive look of the sports coupé is further accentuated by the wheels - available in 18-inch format as an optional extra.







D S OK 9400

Time to surge ahead



The Mercedes-Benz sports coupé radiates energy. Its assuredness and desire to be on the move are immediately apparent. Thanks to the forwards thrust of the distinctive wedge-shaped design and the wide appearance of the chassis. The sportily moulded front apron with air inlets and a large central star in the radiator grille fit perfectly into the overall scheme of things. Plus you can make the CLC Sports Coupé even more expressive by ordering the optional sports package.









CLC 350



D S OK 9400

Set your expectations high. So that it can do them justice

7 engine variants – 2 diesel and 5 petrol powerplants (including a BlueEFFICIENCY model offering optimum fuel economy) – provide the driving force. Exceptional dynamism and agility come courtesy of the Direct-Steer system and the lowered sports suspension. Both form part of the optional sports package. But the CLC wouldn't be a Mercedes if it didn't combine all of this sportiness with a high standard of comfort. Cue the fast-response transmission, standard-fit sports seats and exclusive interiors, for example.





TrueBlueSolutions

Climate change is one of the major challenges of the 21st century. The rising consumption of natural resources is having an increasing impact on our planet. As the inventor of the motor car, Mercedes-Benz has a special responsibility to implement innovative technologies in order to develop solutions that help preserve the environment and ensure that raw materials are used as efficiently as possible – without compromising on comfort, safety and driving enjoyment. We call them TrueBlueSolutions.

Our goal is emission-free mobility. To achieve this goal, we have developed a number of concepts, one of which is **BlueEFFICIENCY**. This custom-designed package of efficiency measures can reduce fuel consumption by up to 12 %: various aerodynamic and energy-management measures are implemented individually for each model to maximise savings in each case. These include tyres with low rolling resistance, lightweight materials, changes to the body aerodynamics and the automatic ECO start/stop function. As for

diesel engines, Mercedes-Benz has brought to market its **BlueTEC** technology based on common-rail direct injection (CDI). This technology is the embodiment of the world's cleanest diesel as it can reduce nitrogen oxides by up to 80 %. Great things are also expected of **BlueHYBRID** technology - a combination of a highly efficient internal combustion engine and an electric motor. Vehicles equipped with this drive system raise the bar once again in terms of economy and cleanliness, as will be shown by the S-Class from 2009 onwards. Mercedes-Benz calls the equivalent technology for diesel vehicles **BlueTEC HYBRID**. A prototype



BlueTEC. The world's cleanest diesel technology in a modern-day vehicle. The E-Class is also available with BlueTEC technology

version of this system can be seen in the Vision GLK 300 BlueTEC HYBRID¹, which is currently the world's cleanest and most economical SUV. It returns a combined consumption figure of just 5.9 l/100 km. And with the F700 research vehicle, we have succeeded in combining the advantages of a petrol engine with those of a diesel powerplant. The **DIESOTTO** drive at the heart of the F700 may have petrol in the tank; however, it operates like an economical diesel model in many driving situations. Mercedes-Benz also sees great potential in the development of the fuel cell. This highly promising drive system requires no



BlueEFFICIENCY. Numerous models, various measures, one goal: maximum efficiency

mineral fuel whatsoever and operates with zero emissions. The first of these vehicles to be built under series-production conditions – the B-Class F-CELL – is due in 2010.

However, our extensive TrueBlueSolutions concept does not just include new drive technologies. Under the banner **Design for Environment**, we look at the vehicle's entire lifecycle – from planning to recycling. The same applies to the building and running of new plants. We save energy, avoid pollutants and increase the use of renewable raw materials. Incidentally, Mercedes-Benz is the



BlueHYBRID. Looking forward to one of the world's most economical luxury saloons. The S-Class from 2009

world's only car brand to have received the independently awarded TÜV² environmental certificate. TrueBlueSolutions also involves the active participation of the Group and its employees in environmental protection measures both inside and outside the company's plants. And it incorporates a commitment to developing second-generation alternative fuels (BTL/Biomass-to-Liquid fuels), such as SunDiesel[®], which are not at odds with food production. Another aspect of TrueBlueSolutions is the research discipline of bionics, which looks at structures and designs in the natural world in order to optimise the



BlueTEC HYBRID. The Vision GLK 300 BlueTEC HYBRID¹ is the most efficient combination of BlueTEC diesel and hybrid modules

weight and aerodynamics of body constructions, for example. Last but not least, you can also do your bit for TrueBlueSolutions by adapting your driving style.

For further information on our extensive package of measures, go to www.mercedes-benz.com/truebluesolutions

¹ Provisional figures: combined fuel consumption: 5.9l/100 km; overall CO₂ emissions: 157 g/km

The figures are not based on an individual vehicle and do not constitute part of the product offer; they are provided solely for purposes of comparison between different vehicle models

² TÜV SÜD Management Service GmbH, Munich



F-CELL. Emission-free mobility with the drive system of the future: the B-Class F-CELL goes into production in 2010



Generous in terms of output. Mean on fuel

Strong performers and strong fuel savers - thanks to common-rail diesel technology

Environmental awareness begins at home. On your doorstep, to be precise. Especially if this is where you get into your car. State-of-the-art common-rail diesel technology with a particulate filter as standard has a positive impact on the ecological balance sheet of the CLC 200 CDI developing 90 kW (122 hp) and the CLC 220 CDI delivering 110 kW (150 hp). As it also does on their fuel consumption. It's nice to know that the engines' performance figures, too, leave nothing to be desired, while their smoothness is astonishing.

All the cylinders of the common-rail engine are supplied with fuel via a shared line. Injection is

metered with the utmost precision, while the degree of pressurisation is extremely high. As a result, the full torque is available very soon - at just above idle speed.

CLC 220 CDI

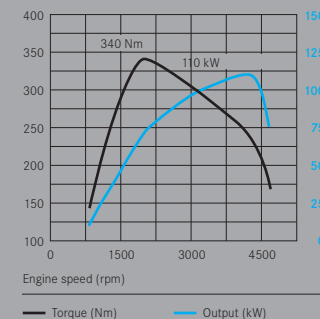

Equipped with common-rail diesel technology, the CLC 220 CDI delivers high torque even at low revs







Designed to drive your enthusiasm as well as your car

The petrol engines - maximum torque even at low revs

Keeness to perform and environmental compatibility are at the heart of the petrol engines for the CLC Sports Coupé. The two 6-cylinder variants deliver their power reserves with an impressive show of strength and spontaneity - the CLC 230 with 150 kW (204 hp) and the CLC 350 with 200 kW (272 hp). High torque is available even at low revs, making the engines extremely powerful performers. For instance, the CLC 350 takes just 6.3 seconds to sprint from 0 to 100 km/h while the CLC 180 KOMPRESSOR

with 105 kW (143 hp) and the CLC 200 KOMPRESSOR with 135 kW (184 hp) are pleasingly economical on fuel consumption yet as generous as ever with regard to dynamics. But our commitment to sustainable mobility and environmental protection is no less legendary. The latest example of this is the 95 kW (129 hp) CLC 160 BlueEFFICIENCY which combines driving pleasure with particularly low fuel consumption and reduced emissions. Classic Mercedes qualities, in fact.

CLC 200 KOMPRESSOR

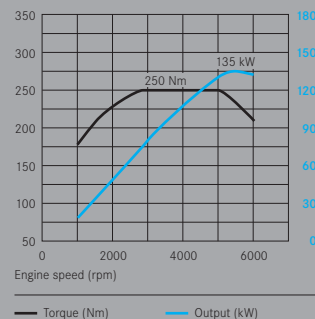

CLC 230

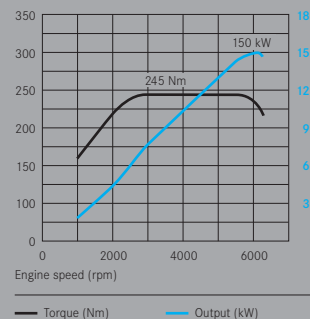

CLC 350

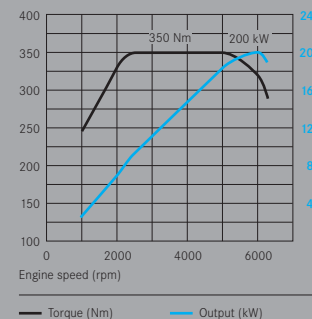

In the BlueEFFICIENCY models numerous fine-tuning measures are combined to reduce both fuel consumption and CO₂ emissions

The best transmissions are the ones that go unnoticed

Fast, precise, exciting: the manual and automatic transmissions

Power is nothing without control. This is why the fast-response transmissions for the CLC are designed to work together with you. The DIRECT CONTROL 6-speed manual transmission sends the power where it belongs: to the road, and that with unerring precision. Fast gear changes are also the order of the day with the optional 5-speed automatic transmission and the 7G-TRONIC automatic

transmission, which is available as an optional extra for the 6-cylinder models. Powerful acceleration in any gear is part of this transmission's genetic makeup – thanks largely to the multiple downshift function. The CLC's shift times are so fast that the route will never seem long enough. Not only does this sound impressive, it also enhances comfort.

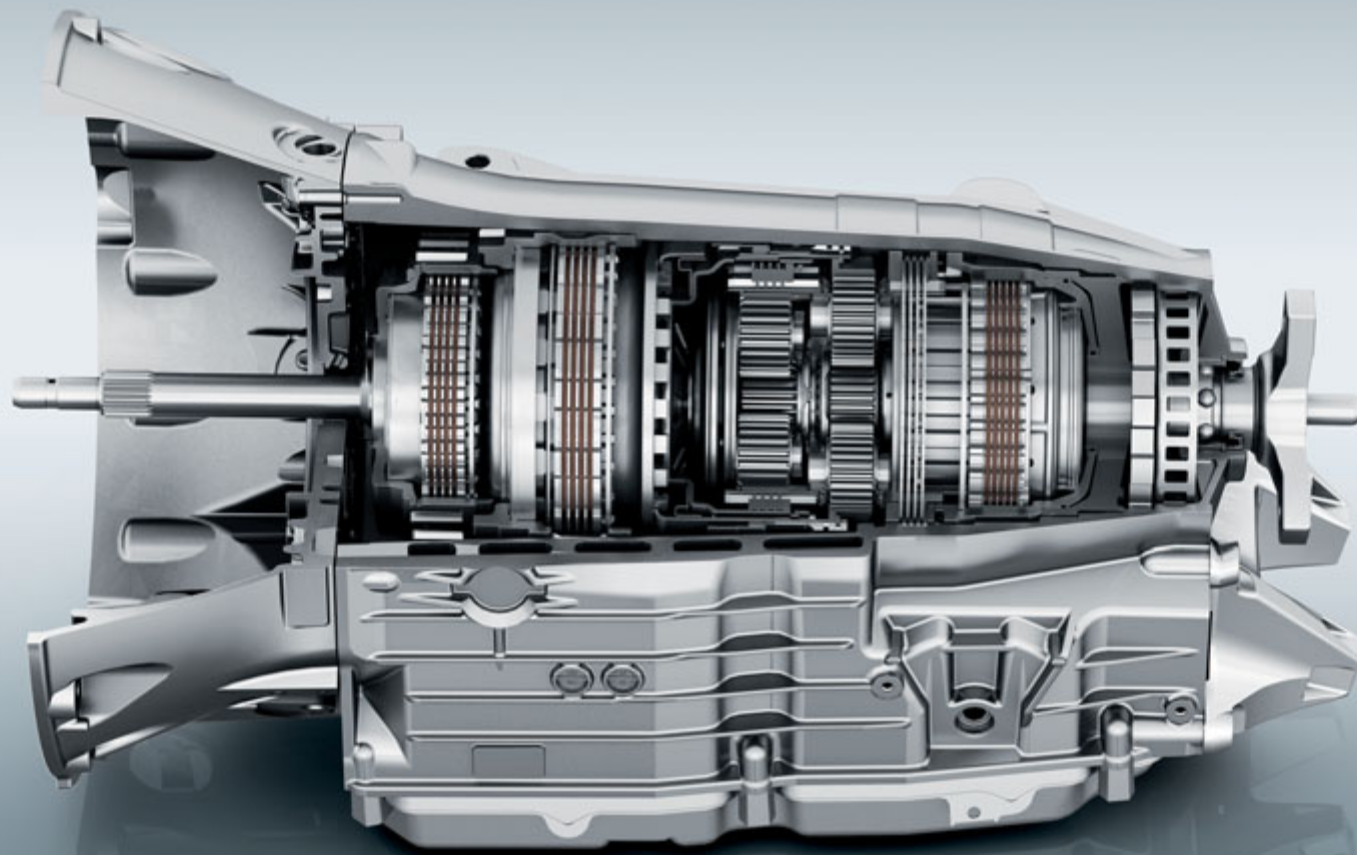

7G-TRONIC: developed with the experience gained from producing more than eleven million automatic transmissions in over 40 years



Only telepathy is more direct

Enticingly sporty, delightfully direct: suspension and steering

You hold the steering wheel with both hands. Each new bend triggers a sense of eager anticipation. With its wide track and taut tuning, the CLC's DIRECT CONTROL suspension sweeps through every bend with sporty flair. The lowered sports suspension, available as an optional extra, does full justice to its name courtesy of some exceptionally dynamic characteristics.

Similarly the Direct-Steer system – part of the optional sports package – makes you feel a close affinity with the road. It enhances both the agility and the comfort of the CLC by varying its ratio in line with the steering-wheel angle. So even the shortest of trips becomes a pleasure to savour – at every apex.

Maximum excitement. Minimum risk

Active occupant protection for the sports coupé

The CLC is clearly in its element on the road. And to make sure this is where it stays, an impressive array of safety systems helps to prevent accidents before they even get a chance to happen. The Electronic Stability Program ESP® is able to apply the brakes precisely at each individual wheel in the event of over- or under-steer, while Brake Assist (BAS) helps bring the CLC to a stop as quickly as possible when the brakes are applied in an emergency.

Further active-safety components include the anti-lock braking system ABS and the optionally available bi-xenon headlamps with cornering light function, which ensure exceptionally bright illumination of a wide section of the road. Plus the fog lamp on the side of the car in question is activated when the car starts to make the turn. Thus you can see whether the way ahead really is clear in plenty of time.





Hopefully you'll never see a repeat of what what we're about to show you

Passive occupant protection for the CLC

Dynamism is at its most stunning when it is under control. This comfortable feeling is built into the CLC. The safety body with its high-strength passenger cell and supporting structure capable of withstanding extremely high loads, along with energy-absorbing deformation zones, forms the heart of the safety concept. Efficient occupant protection is also provided by the airbags. The CLC features front airbags with two-stage deployment as well as front sidebags and windowbags. All the seats in the sports coupé are

equipped with 3-point seat belts. In addition, highly effective belt tensioners and intelligent belt-force limiters contribute to the outstanding level of occupant protection afforded by the CLC Sports Coupé.

Further information about the Mercedes-Benz safety concept is available online at www.mercedes-benz.com/airbag-brochure

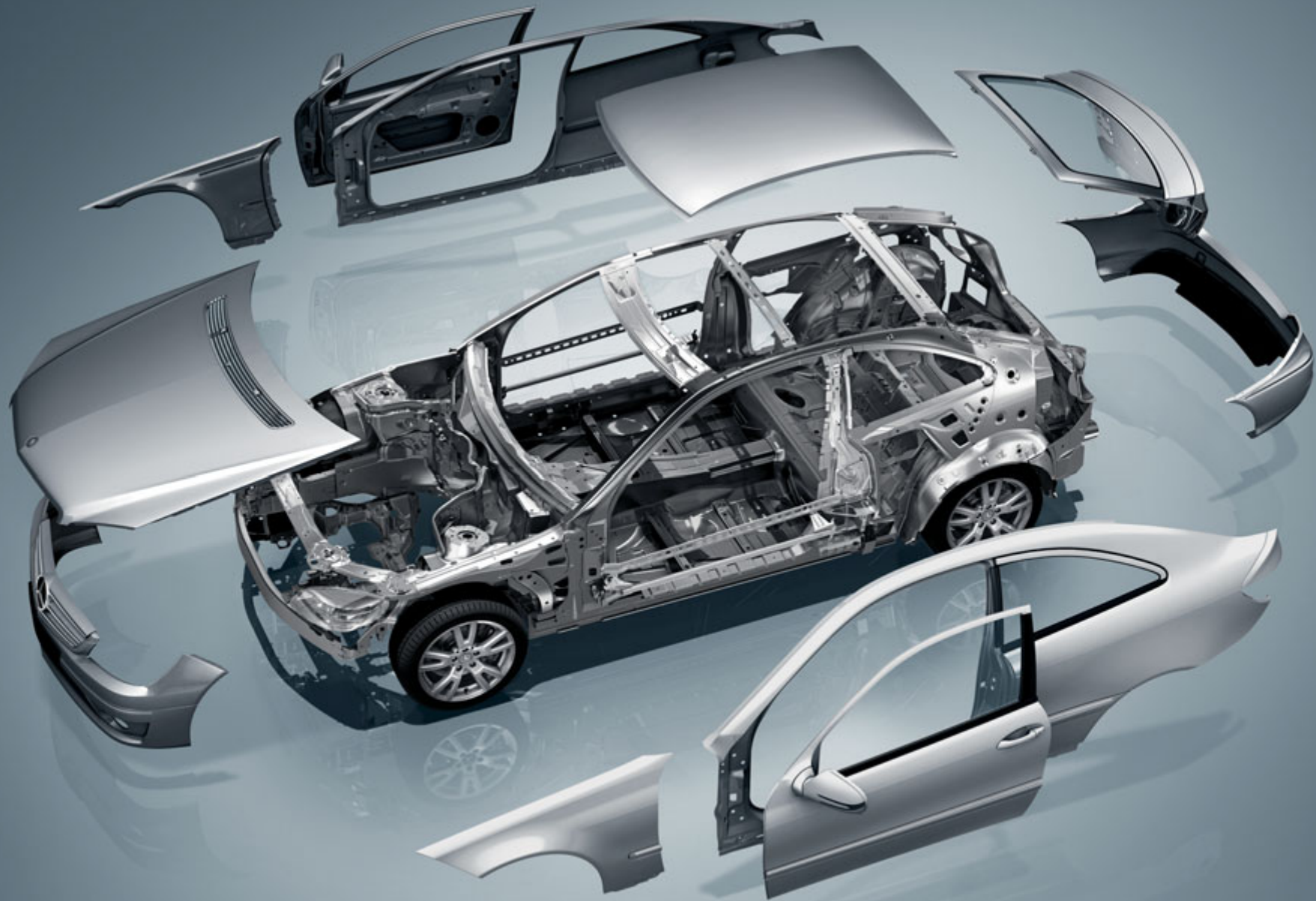





Exclusivity for all five senses. Controllable with the sixth

The cockpit equipment

Opening the driver's door reveals a space that you may not have been expecting. Not just size-wise but, above all, in terms of the harmonious blend of exclusivity and high-quality materials with sporty design. Features such as the standard automatic climate control THERMATIC further add to the enhanced ride comfort.

Impressively dynamic: the appearance of the sporty instrument cluster with distinctive white

needles. Astonishingly intuitive: the controls for key functions. Whether it be the arrangement of the switches or the layout of the instruments, everything is where you would instinctively expect it to be. Without having to chance a second look. Not only is this safer, it also makes driving an even more pleasurable experience. Furthermore, the 3-spoke multifunction steering wheel ensures that even central functions can be controlled quickly and easily.

Sporty and muscular meets suave and sophisticated

Extremely pleasing on the eye: the interior of the sports coupé

Agility and comfort are not always easy bedfellows. But they are when you're ensconced in the standard-fit sports seats. Their good looks are matched by the level of support they offer you whilst driving. They even help you to get into the rear. Simply fold down the backrest – and the EASY-ENTRY system moves the front seats forwards. As well as making life easier, the interior of the CLC is easy

on the eye. Exciting contrasts and high-quality materials – like the optionally available leather appointments in alpaca grey – create an exclusive ambience, while trim elements in brushed aluminium or optionally available black bird's-eye maple are combined with black carpet and pale seat and door centre panels. So when you next drive to a luxury suite, you'll already feel as if you're in one.







The view outside is as impressive as the one inside

The panoramic sunroof - in its element whatever the weather

Below you, hallmark Mercedes exclusivity. Above you, the open sky. The panoramic sunroof, available as an optional extra for your CLC, opens up a whole new perspective and allows light to flood into the interior, giving a hint of that special open-air feeling you only usually get when driving a cabriolet. That's because, beneath the large panoramic panel spanning the entire roof surface, it's almost like sitting beneath the open sky. You can add to this feeling by moving the front section of the roof rearwards at the touch of a button -

without restricting headroom in the rear in the least.

At the rear, the panoramic sunroof merges into a large tailgate that allows even heavy and bulky items to be loaded with ease. Thanks to a boot capacity of 310 litres (with the luggage cover) or up to 1100 litres (with the rear seat backrests folded down), your CLC has plenty of space for your luggage-carrying requirements. So there's no need to leave anything behind.

Infotainment for the i-generation

Multimedia freedom thanks to Bluetooth, media interface and Dolby Digital 5.1 surround sound

Welcome to the communications society: for information, communication, navigation and entertainment the CLC offers the latest audio and communications solutions, equipped as standard with user-friendly colour displays that connect the mobile phone wirelessly with the hands-free feature. Simply intuitively functional.



Bluetooth interface display

To begin with, there is the optional Audio 20 CD with an integrated CD player or optionally with an integrated CD changer for 6 CDs, MP3 capability, 5-inch display and Aux-in connection in the glove compartment.

Over and above these functions, the Audio 50 APS system offers you a convenient DVD arrow-based navigation function with junction zoom and Traffic Message Channel (TMC).

Completing the line-up, the COMAND APS multimedia system impresses with its hard-disc navigation, Birdview and high-resolution 6.5-inch display. Further components of the system are: the intuitive voice-operated control system LINGUATRONIC, 4 GB memory for audio files (MUSIC REGISTER) and a socket for SD memory cards.

With the optional media interface, for the first time it is possible to integrate an iPod, USB stick or other external audio devices into the CLC operating system. This way, the track titles are shown in the display and can be controlled with the buttons of the multifunction steering wheel (available from Audio 20 CD with a 6-disc CD changer upwards).

Finding yourself getting into the car whenever you want to listen to music is also part of the CLC effect. The optional Harman Kardon® Logic 7® surround sound system provides the ideal listening experience with its 450-watt output and perfectly adjusted surround sound featuring Dolby Digital 5.1 and DTS technology.



RADIO DISC

NAVI TEL

SYS

KK DD

ON

01:59

TA

Navi

Audio

Tel

Video

System

1 No one

01:51

iPod 70&80

Alicia Keys

Media Interface

Music

Medium

Sound

1

2

3

00

ABC

DEF

4

5

6

GHI

JKL

MNO

7

8

9

PQRS

TUV

WXYZ

*+

+

0

#

L

←

C

OK

AUTO

OFF







My CLC-Class

Sport de luxe

The sports package for your CLC

A special impression requires a special expression. Something the CLC derives from the optional sports package. Its body hugs the road more closely, thanks to the sports suspension, while the innovative variable-ratio Direct-Steer system is also a part of the sports package. You will feel it in the form of even more direct handling and enhanced agility.

You can tell the sporty tailoring for your CLC above all by the 5-twin-spoke 18-inch light-alloy wheels. Darkened projection-beam headlamps and a radiator grille with black louvres and chrome highlights underscore the car's expressiveness.



The air intake grille with its atlas grey mesh design



The sound-optimised exhaust system



CLC 200



S 0U 9221



The 3-spoke leather sports steering wheel continues the dynamic theme of the sports package in the interior. Dark brushed aluminium trim elements and an instrument cluster with red needles and chequered-flag design set the tone. When the key is inserted and turned in the ignition, the speedometer and rev counter spring to life. The needles swiftly abandon their 6 o'clock position and sweep the complete dial, to return to the starting position after a fraction of a second. This is just a selection of the benefits. Others include the standard seats in ARTICO man-made leather with a perforated seat surface. For the even more discerning, leather appointments in cognac brown are available as an exclusive optional extra in conjunction with the sports package. After all, uniqueness is the norm for the CLC with the sports package.



The easy-grip leather sports steering wheel



The studded stainless-steel sports pedals

Luxury is also about personal preference

For discerning tastes: exclusive package and comfort package

The upgraded appointments in the exclusive package are designed for those who feel that even everyday luxury is too ordinary. This package enables you to further personalise the CLC with a wide range of options, for example the memory function for the driver's and front-passenger seat settings or the luxury automatic climate control THERMOTRONIC.



The electric seat adjustment with memory function

Those who spend a lot of time on the road will feel perfectly at home in the CLC with the comfort package. Useful features of this equipment package include a rain sensor, electrically folding exterior mirrors and an automatic dimming function for the driver as well as a tyre pressure loss warning system, all with the focus firmly on comfort and convenience.



Luxury automatic climate control THERMOTRONIC



Tyre pressure loss warning system



Rain sensor



One of the electric exterior mirrors



The exterior mirror, electrically folded

STANDARD EQUIPMENT (Selection)

3-point seat belts, height-adjustable in front; with automatic height adjustment in rear

Airbags and sidebags for driver and front passenger, plus windowbags for driver, front passenger and rear passengers

ASSYST service interval indicator

Belt tensioners with belt force limiters front and rear

Brake Assist (BAS)

Central locking with interior switch and crash sensor

Chrome package: chrome highlights for bumpers and rub strips

Clear-lens headlamps, indicators, tail lights and brake lights with high-gloss effect

Cruise control with SPEEDTRONIC variable speed limiter

Designer key (ignition key with chrome highlight)

DIRECT CONTROL 6-speed manual transmission

DIRECT CONTROL power steering with safety steering column

DIRECT CONTROL suspension

Door sill panels with "Mercedes-Benz" lettering

EASY-ENTRY system for rear passengers

Electronic Stability Program ESP®

Exterior mirrors with integrated LED indicators

Fabric/ARTICO man-made leather upholstery

First-aid kit

Front armrest, height-adjustable, with stowage compartment and cup holder

Front fog lamps

Front sports seats with reinforced lateral support



Wide coupé radiator grille with chrome highlights



The two-tone tail lights and third brake light



The exterior mirror with integrated LED indicator

STANDARD EQUIPMENT (Selection)

Headlamp Assist

Headlamp range adjustment

Heated rear window

Immobiliser with ELCODE locking system and infrared remote control

Outside temperature display

Particulate filter for diesel models

Power windows (2) with one-touch control and obstruction sensor

Seat occupancy sensor for front passenger seat

Side-impact protection

Steering column manually adjustable for height and reach

Sun visor with vanity mirror

THERMATIC automatic climate control with separate temperature control for driver and front passenger, dust filter and activated charcoal filter and air recirculation switch with convenience function and ventilation outlets for the rear

Three-spoke multifunction steering wheel

Through-loading facility, rear bench seat folds fully or with 1/3 : 2/3 split

Tinted glass

TIREFIT tyre sealant with electric pump

Trim elements in light brushed aluminium

Trip computer in the multifunction display

Warning buzzer that sounds if the vehicle lights are left on and the parking brake is applied

Windscreen wiper system with one-touch control



Automatic climate control with aluminium trim elements



Headlamp Assist



Designer key

OPTIONAL EXTRAS (Selection)	CLC 200 CDI	CLC 220 CDI	CLC 160 BlueEFFICIENCY	CLC 180 KOMPRESSOR	CLC 200 KOMPRESSOR	CLC 230	CLC 350
7G-TRONIC 7-speed automatic transmission	-	-	-	-	-	●	●
Bi-xenon headlamps with dynamic range control and cornering light function	●	●	●	●	●	●	●
COMAND APS, multimedia system	●	●	●	●	●	●	●
Harman Kardon® LOGIC 7® surround sound system	●	●	●	●	●	●	●
Heat-insulating dark-tinted glass for rear side windows and rear window	●	●	●	●	●	●	●
Leather steering wheel and leather gearshift lever	●	●	●	●	●	●	●
Panoramic sunroof and sun visors with illuminated vanity mirror	●	●	●	●	●	●	●
Sidebags in rear	●	●	●	●	●	●	●
Sports suspension	●	●	●	●	●	●	●
Trim elements in bird's-eye maple	●	●	●	●	●	●	●

● Optional extra ○ Standard - Not available



The dark-tinted, heat-insulating glass at the rear



The panoramic sliding sunroof



The bi-xenon headlamps with cornering light function

EQUIPMENT PACKAGES (Selection)	CLC 200 CDI	CLC 220 CDI	CLC 160 BlueEFFICIENCY	CLC 180 KOMPRESSOR	CLC 200 KOMPRESSOR	CLC 230	CLC 350
Comfort package: rain sensor, interior mirror and driver's-side exterior mirror with automatic dimming function, exterior mirrors left and right electrically folding, tyre pressure loss warning system	●	●	●	●	●	●	●
Exclusive package: memory function for electrical adjustment of front seats, steering column and exterior mirrors as well as luxury automatic climate control THERMOTRONIC	●	●	●	●	●	●	●
Sports package: including Direct-Steer system, sports suspension, 18-inch 5-twin-spoke light-alloy wheels, ARTICO man-made leather upholstery in a choice of 2 variants, 3-spoke leather sports steering wheel with multifunction capability	●	●	●	●	●	●	●

● Optional extra ○ Standard - Not available



The Audio 50 APS radio with DVD navigation system



The voice-operated control system LINGUATRONIC



PARKTRONIC with LED display

Create an even greater impression – the wheels for your CLC

OPTIONAL EXTRAS



Optional extra: 16-inch 5-spoke light-alloy wheel
(standard on CLC 230)



Optional extra: 17-inch 5-twin-spoke light-alloy wheel
(standard on CLC 350)



Optional extra: 17-inch 5-twin-spoke light-alloy wheel



Optional extra: 17-inch 6-spoke light-alloy wheel



Standard for sports package: 18-inch 5-twin-spoke
light-alloy wheel



Optional for sports package: 18-inch multi-spoke
light-alloy wheel

AMG



Optional extra: 18-inch AMG 5-spoke light-alloy wheel

ACCESSORIES



Genuine accessories: 18-inch incenio "Almuredin" designer wheel painted in high-shine titanium silver

There is a broad palette of sporty wheel designs available for the CLC, depending on the engine size. But, whether you favour 16-inch, 17-inch or 18-inch wheels: all of them accentuate the sport coupé's expressive appeal.



An ideal starting point – genuine accessories

As well as being styled for maximum appeal, each and every detail of a Mercedes is also designed for maximum practicality. Take the handy accessories such as the aerodynamic roof box or the swivelling ski and snowboard rack, for instance. Not only does your equipment stay safe and well protected until you arrive at your destination, it is also easy to load and unload.



Ski and snowboard rack

Furthermore, practical luggage nets allow you to stow loose items such as toys, footballs or running shoes out of harm's way whilst you are driving. So there's a safe place for everything on board the CLC. And there is one other thing you can be sure of: only genuine Mercedes accessories are designed to fit your Mercedes perfectly.



Luggage nets for the boot floor and the boot sill

The CLC paintwork puts the finishing touch to the carefully crafted Mercedes-Benz corrosion protection system, which includes zinc phosphating and electrophoretic dip priming of the body for long-lasting protection. We also make very extensive use of eco-friendly water-based paints.

NON-METALLIC PAINTS



040 black

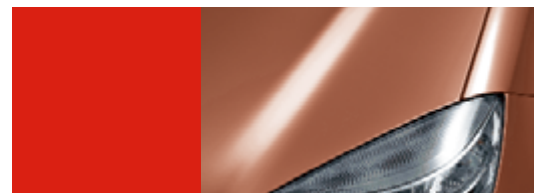

590 fire opal



650 calcite white

METALLIC PAINTS



112 chromite black



359 tanzanite blue



755 tenorite grey



197 obsidian black

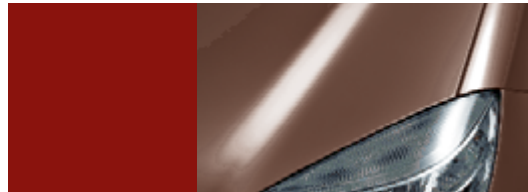

544 carneol red



775 iridium silver



345 jasper blue



723 cubanite silver

FABRIC/ARTICO MAN-MADE LEATHER

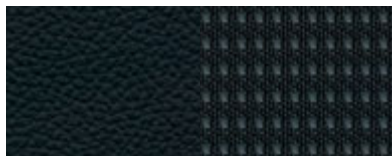

721 black/black

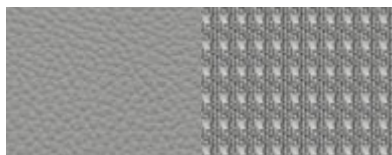

728 alpaca grey/alpaca grey

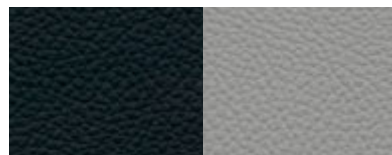

767 black-red/black

ARTICO MAN-MADE LEATHER¹171 black²178 alpaca grey³

LEATHER



241 black

244 cognac brown¹

248 alpaca grey

TRIM ELEMENTS

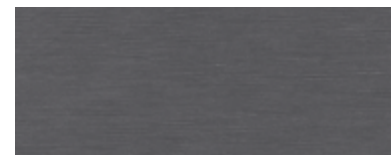

Brushed aluminium, light

Brushed aluminium, dark¹

Wood, black bird's-eye maple

¹ Only available for sports package² Centre console, door lining, rear side trim and carpeting in black, seats in alpaca grey/black³ Centre console, door lining, rear side trim in alpaca grey, carpeting in black, seats in alpaca grey/black

	FABRIC/ARTICO MAN-MADE LEATHER	black / black alpaca grey / alpaca grey black-red / black	ARTICO MAN-MADE LEATHER	black alpaca grey	LEATHER	black cognac brown alpaca grey
NON-METALLIC PAINTS						
black	●	● ● ●		● ●		● ● ●
fire opal	●	● ● ○		● ●		● △ ●
calcite white	●	● ● ●		● ●		● ● ●
METALLIC PAINTS						
chromite black	●	● ● ●		● ●		● △ ●
obsidian black	●	● ● ●		● ●		● ● ●
jasper blue	●	○ △		● ○		● △ ○
tanzanite blue	●	● ● ○		● ●		● ○ ●
carneol red	●	● ● ●		● ●		● △ ●
cubanite silver	●	● ● ○		● ●		● ● ●
tenorite grey	●	● ● ○		● ●		● ○ ●
iridium silver	●	● ● ●		● ●		● ● ●

● Recommended

○ Possible

△ Not recommended

	CLC 200 CDI	CLC 220 CDI	CLC 160 BlueEFFICIENCY ¹	CLC 180 KOMPRESSOR
No. of cylinders/arrangement	4/in-line	4/in-line	4/in-line	4/in-line
Total displacement (cc)	2148	2148	1597	1796
Rated output ² (kW at rpm)	90/4200	110/4200	95/5000	105/5200
Rated torque ² (Nm at rpm)	270/1600–2800	340/2000	220/2500–3800	220/2500–4200
Compression ratio	18.0	18.0	9.3	9.3
Acceleration 0–100 km/h (s) (automatic transmission)	11.3 (11.1)	9.7 (9.4)	11.2 (11.5)	9.7 (9.9)
Top speed, approx. (km/h) (automatic transmission)	206 (205)	224 (219)	210 (206)	220 (215)
Tyre size				
Front	205/55 R 16	205/55 R 16	205/55 R 16	205/55 R 16
Rear	205/55 R 16	205/55 R 16	205/55 R 16	205/55 R 16
Fuel	Diesel	Diesel	Premium	Premium
Fuel consumption ⁴ (l/100 km)				
Urban (automatic transmission)	7.7–7.9 (8.8–8.9)	7.8–8.1 (8.8–8.9)	9.8–10.2 (10.6–10.9)	11.0–11.3 (11.1–11.7)
Extra-urban (automatic transmission)	4.7–5.1 (5.4–6.1)	4.8–5.2 (5.2–5.6)	5.5–5.9 (5.9–6.2)	5.7–6.2 (5.9–6.4)
Combined (automatic transmission)	5.8–6.1 (6.6–7.1)	5.9–6.3 (6.6–6.8)	7.1–7.5 (7.6–7.9)	7.7–8.1 (7.8–8.3)
CO ₂ emissions combined ⁴ (g/km) (automatic transmission)	152–161 (174–188)	156–166 (172–179)	169–178 (181–189)	182–192 (186–198)
Tank capacity (l), including reserve, approx.	62/8	62/8	62/8	62/8
Turning circle (m)	10.76	10.76	10.76	10.76
Kerb weight ⁵ (kg)	1505	1530	1470	1475
(automatic transmission)	(1525)	(1550)	(1490)	(1495)
Permissible gross vehicle weight (kg)	1960	1985	1940	1945
(automatic transmission)	(1960)	(1985)	(1940)	(1945)

	CLC 200 KOMPRESSOR	CLC 230	CLC 350
No. of cylinders/arrangement	4 /in-line	6/V	6/V
Total displacement (cc)	1796	2496	3498
Rated output ² (kW at rpm)	135/5500	150/6100	200/6000
Rated torque ² (Nm at rpm)	250/2800-5000	245/2900-5500	350/2400-5000
Compression ratio	8.5	11.2	10.7
Acceleration 0- 100 km/h (s) (automatic transmission)	8.6 (8.7)	8.4 (8.6)	6.3 (6.3)
Top speed, approx. (km/h) (automatic transmission)	235 (231)	240 (234)	250 ³ (250 ³)
Tyre size	Front	205/55 R 16	225/45 R 17
	Rear	205/55 R 16	225/45 R 17
Fuel	Premium	Premium	Premium
Fuel consumption ⁴ (l/ 100 km)			
Urban (automatic transmission)	11.0- 11.4 (11.6- 11.9)	13.3- 13.6 (13.2- 13.4)	13.7- 14.0 (13.9- 14.2)
Extra-urban (automatic transmission)	5.9- 6.4 (6.2- 6.7)	6.7- 7.1 (6.8- 7.3)	7.0- 7.3 (7.3- 7.6)
Combined (automatic transmission)	7.8- 8.2 (8.1- 8.6)	9.2- 9.5 (9.1- 9.5)	9.5- 9.8 (9.7- 10.0)
CO ₂ emissions combined ⁴ (g/km) (automatic transmission)	185- 196 (194- 204)	218- 225 (217- 226)	227- 234 (232- 239)
Tank capacity (l), including reserve, approx.	62/8	62/8	62/8
Turning circle (m)	10.76	10.76	10.76
Kerb weight ⁵ (kg)	1480	1525	1550
(automatic transmission)	(1500)	(1545)	(1570)
Permissible gross vehicle weight (kg)	1950	1995	2020
(automatic transmission)	(1950)	(1995)	(2020)

¹ Due to be available from the 1st quarter of 2009 ²Figures according to Directive 80/1269/EEC in the currently applicable version ³Electronically limited ⁴The figures shown were obtained in accordance with the prescribed measuring process (Directive 80/1268/EEC in the currently applicable version). The data does not refer to an individual vehicle and is not part of the offer, but only serves as a means of comparison between different vehicle models

⁵ Figures according to Directive 92/21/EC, as amended by 95/48/EC (kerb weight with fuel tank 90 % full, driver, 68 kg, and luggage, 7 kg) for standard-specification vehicles. Optional extras and accessories will generally increase this figure and reduce the payload accordingly

How much space will the CLC take up in your life?

The CLC dimensions at a glance

We could write at great length about its everyday practicality. Or about the fact that it is one of the shortest and lowest-slung Mercedes-Benz

models of all. But we think you should drive it yourself first. You can see the rest on the illustrations below.

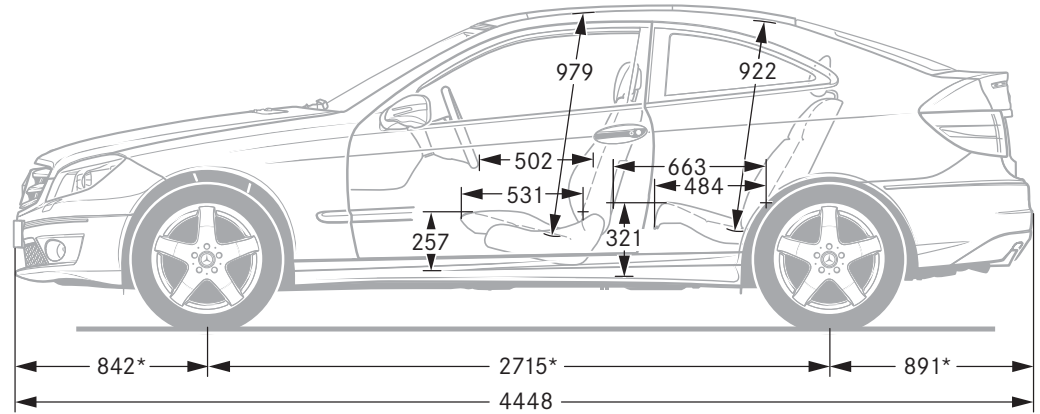
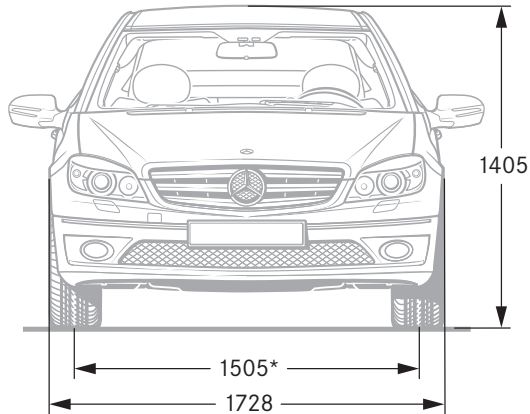

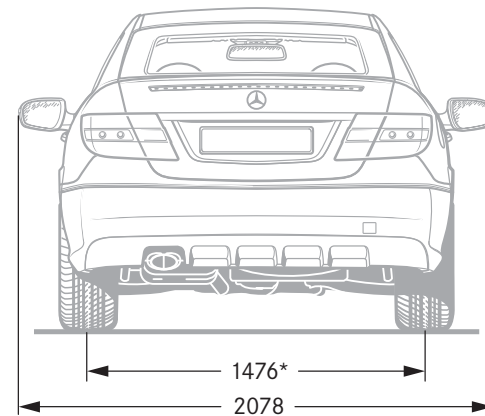
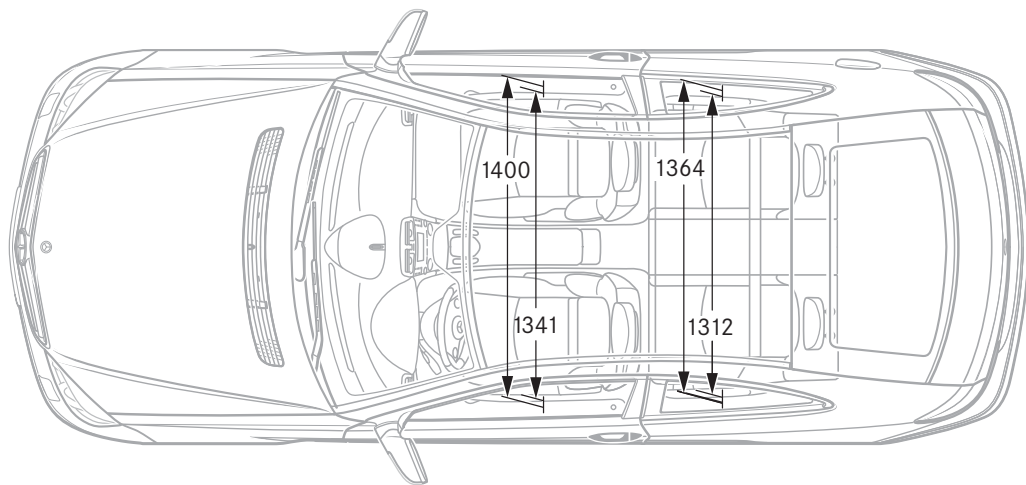

All measurements in millimetres. The dimensions shown are mean values and apply to standard-specification, unladen vehicles

* Carrying 3 people, each weighing 68 kg



Anyone opting for a Mercedes buys far more than just a car

Comprehensive service offered by Mercedes-Benz

Mercedes-Benz Service24h

The feel-good factor, which kicks in when you sit behind the wheel of your new Mercedes for the first time, is further enhanced by the knowledge that Mercedes-Benz Service24h is there for you around the clock – 365 days a year. Experience shows that your Mercedes model is extremely unlikely to suffer a technical problem or breakdown. And even if the unthinkable happens, you can always count on Mercedes-Benz Service24h, wherever you are in Europe. Just call our Service Hotline on 00800 1 777 7777¹ at any time. One of our specialists will take your call and arrange professional assistance for you immediately. By the time you put down the phone, our Service24h team will be getting ready to make their way to you. It will often be possible to sort out the problem at the scene. If this is not the case, however, we will of course arrange for your car to be taken to the nearest Mercedes-Benz workshop.

MercedesCard

Your ticket to the Mercedes-Benz experience: the quarterly MercedesCard ARGENTUM journal offers you an exclusive selection of exciting events starring the Mercedes-Benz brand. In addition, the Mercedes magazine is packed with gripping and inspiring articles and reports. The MercedesCard has many other functions: as a VISA credit card, it is an accepted form of payment worldwide – with no annual fee if you complete a questionnaire every year. In addition, it offers further benefits to put your mind at ease, such as the Mercedes-Benz insurance package, at no extra charge, and the exclusively compiled MercedesCard insurance package at a preferential rate. For further information about this offer, available exclusively to Mercedes-Benz drivers, visit www.mercedes-benz.de/mercedescard²

Mercedes-Benz Bank

If you have already chosen your dream car and want to remain financially flexible, the Mercedes-Benz Bank should be your next port of call. We are your one-stop shop for leasing, financing, insurance and service packages. By way of example, our “Private Leasing plus” scheme is a complete package comprising leasing, insurance and a purchase option, while our “Plus3” finance package combines low rates with high flexibility. That’s because, at the end of the contract, you decide yourself whether to keep your car, sell it or return it to us for a guaranteed price. We also offer an attractive range of investment products, including instant-access savings accounts, fixed-interest products and investment funds. For further information, please call us on 01803/32 22 65³ or visit us at: www.mercedes-benz-bank.de

¹ Freephone number, mobile-phone rates may vary

² Information about the MercedesCard in Austria and Switzerland can be found on the Mercedes-Benz websites for these countries

³ 9 ct/min from Deutsche Telekom landlines, mobile-phone rates may vary



Time for another enriching experience

A Mercedes-Benz is most at home on the road. This is the only way to experience the effortlessly superior driving feel that lends every model its inimitable class. Feel the power of the engine as it propels the car forwards. Marvel at the precise steering, designed to really put you in the mood for driving. And experience what true comfort really feels like. The unique feeling of driving a Mercedes cannot be put into words, however. Which is why we'd like to invite you to take a test drive. Your Mercedes-Benz dealer will be happy to make all the necessary arrangements for you. Simply visit www.mercedes-benz.com to locate the nearest Mercedes-Benz dealer in your country or region. We look forward to seeing you.

The website also offers an interactive tour, enabling you to take a closer look at your desired model. This simulation is the ideal way to acquaint yourself with your dream car. You can view key functions in detail, gain an insight into the car's inner workings or look at the benefits of each model. For further details, visit www.mercedes-benz.de/owners-manual

Now your mobile phone acts as a gateway to the whole Mercedes-Benz world. In addition to an overview of all passenger car models, there are insights into the entire brand world, not to mention a wealth of entertainment offers and direct links to a range of services at www.mercedes.mobi

Take-back of end-of-life vehicles. Coming full circle. At the end of its long life, you can return your CLC-Class to us for environment-friendly disposal in accordance with the EC End-Of-Life Vehicle Directive¹. But that day lies a long way off.

¹ Applies in accordance with national regulations to vehicles up to 3.5 tonnes gross weight. Mercedes-Benz passenger cars have met the statutory regulations governing the suitability of their design for reuse and recycling for a number of years now. A network of vehicle take-back depots and dismantlers has been established which will process your vehicle in an environment-friendly manner. The ways in which both vehicles and parts can be recovered are subject to ongoing development and improvement. Consequently, the CLC-Class will be able to comply with any future increases in the recycling quota within the stipulated time limits. For further information, go to www.mercedes-benz.de or call 00800 1 777 7777.

Please note: changes may have been made to the product since this brochure went to press (15.08.2008). The manufacturer reserves the right to make changes to the design, form, colour and specification during the delivery period, provided these changes, while taking into account the interests of the vendor, can be deemed reasonable with respect to the purchaser. Where the vendor or the manufacturer uses symbols or numbers to describe an order or the subject of an order, no rights may be derived solely from these. The illustrations may show accessories and items of optional equipment which are not part of standard specification. Colours may differ slightly from those shown in the brochure, owing to the limitations of the printing process. This brochure has been compiled by Daimler AG of Germany and is distributed internationally. It provides a general indication of the range of models, features, optional extras and /or colours available in various countries. Some of the models, features, optional extras and /or colours shown may not be available in your country or may only be available in a different specification. Additionally some models, features, optional extras and /or colours may only be available in combination with others. For current and more specific information in relation to the range of models, features, optional extras and /or colours available in your country, and their pricing, you should contact your nearest authorised Mercedes-Benz Passenger Car Dealer. www.mercedes-benz.com