



This Brochure is prepared by Daimler AG and it predominantly reflects the capabilities and performance of vehicles sold in Europe. Some characteristics, capabilities, performance features and optional extras (e.g. towing systems) may not be available or may not apply in Australia or under Australian conditions. The information in this Brochure is therefore indicative, illustrative and provided only for guidance and should not be relied on. To obtain current and accurate information on a vehicle and any options applicable to Australia, contact your local authorised Mercedes-Benz dealer.

Mercedes-Benz



Mercedes-Benz

The GL-Class

“Our philosophy is very simple.
We give our best for people who expect the best.”

Dr Dieter Zetsche

The GL-Class	08	My GL-Class	48
REFINEMENT		EQUIPMENT	50
TrueBlueSolutions	10	Basic chrome exterior package	52
V6 engine	12	Off-Road Pro engineering package	54
V8 engines	14	Standard equipment	56
Transmissions	18	Light-alloy wheels	60
Suspension	20	Exterior chrome package	62
		Optional extras	64
OFF-ROAD	22	GENUINE ACCESSORIES	74
Off-Road Pro engineering package	24	COLOURS AND MATERIALS	76
		Paintwork	78
COMFORT		Leather	80
Cockpit	28	Wood	81
Interior	30	Possible combinations	82
INTEGRAL SAFETY CONCEPT	36	TECHNICAL DETAILS	
Safe driving	38	Technical data	84
In the event of danger	42	Dimensions	85
In an accident	44	SERVICE	86

Exclusivity is best savoured in company

The GL-Class offers first-class travel, on and off-road

There was a time when drivers were quite happy with merely getting from A to B. Times have changed though and drivers have now come to expect far more from their car. For example, today's car should offer sufficient scope for individuality while leaving enough space for company. It should cut a fine figure out on the open road but should not be found lacking when the going gets a little rougher. It should exude exclusiveness, but never extravagance. In short, it must make opposites attract. We have built just such a car: the GL-Class.

The GL is a luxurious, spacious cross-country vehicle that has a great deal to offer, whether you're on your way to a board meeting or to a campfire. It effortlessly handles any itinerary – with its V6 or V8 engines, the 7G-TRONIC automatic transmission and the individually programmable AIRMATIC air suspension. The masculine design is a joy to behold and the ample interior seats up to seven people.

The hopes and wishes of a good many Mercedes connoisseurs have been realised in the new GL-Class. It is destined to set new benchmark standards in many respects because of our engineers' own exemplary work ethic: **one step further.**





Welcome to the GL-Class. Welcome to the club









The GL-Class

TrueBlueSolutions

Climate change is one of the major challenges of the 21st century. The rising consumption of natural resources is having an increasing impact on our planet. As the inventor of the motor car, Mercedes-Benz has a special responsibility to implement innovative technologies in order to develop solutions that help preserve the environment and ensure that raw materials are used as efficiently as possible – without compromising on comfort, safety and driving enjoyment. We call them TrueBlueSolutions.

Our goal is emission-free mobility. To achieve this goal, we have developed a number of concepts, one of which is **BlueEFFICIENCY**. This custom-designed package of efficiency measures can

reduce fuel consumption by up to 12 %: various aerodynamic and energy-management measures are implemented individually for each model to maximise savings in each case. These include tyres with low rolling resistance, lightweight materials, changes to the body aerodynamics and the automatic ECO start/stop function. As for diesel engines, Mercedes-Benz has brought to market its **BlueTEC** technology based on common-rail direct injection (CDI). This technology is the embodiment of the world's cleanest diesel as it can reduce nitrogen oxides by up to 80 %. Great things are also expected of **BlueHYBRID** technology - a combination of a highly efficient internal combustion engine and an electric motor.

Vehicles equipped with this drive system raise the bar once again in terms of economy and cleanliness, as will be shown by the S-Class from 2009 onwards. Mercedes-Benz calls the equivalent technology for diesel vehicles **BlueTEC HYBRID**. A prototype version of this system can be seen in the Vision GLK 300 BlueTEC HYBRID¹, which is currently the world's cleanest and most economical SUV. It returns a combined consumption figure of just 5.9 l/100 km. And with the F700 research vehicle, we have succeeded in combining the advantages of a petrol engine with those of a diesel powerplant. The **DIESOTTO** drive at the heart of the F700 may have petrol in the tank; however, it operates like an economical diesel



BlueTEC. The world's cleanest diesel technology in a modern-day vehicle. The E-Class is also available with BlueTEC technology



BlueEFFICIENCY. Numerous models, various measures, one goal: maximum efficiency



BlueHYBRID. Looking forward to one of the world's most economical luxury saloons. The S-Class from 2009

model in many driving situations. Mercedes-Benz also sees great potential in the development of the fuel cell. This highly promising drive system requires no mineral fuel whatsoever and operates with zero emissions. The first of these vehicles to be built under series-production conditions – the B-Class F-CELL – is due in 2010.

However, our extensive TrueBlueSolutions concept does not just include new drive technologies. Under the banner **Design for Environment**, we look at the vehicle's entire lifecycle – from planning to recycling. The same applies to the building and running of new plants. We save energy, avoid pollutants and increase the use of renewable raw materials. Incidentally, Mercedes-

Benz is the world's only car brand to have received the independently awarded TÜV² environmental certificate. TrueBlueSolutions also involves the active participation of the Group and its employees in environmental protection measures both inside and outside the company's plants. And it incorporates a commitment to developing second-generation alternative fuels (BTL/Biomass-to-Liquid fuels), such as SunDiesel[®], which are not at odds with food production. Another aspect of TrueBlueSolutions is the research discipline of bionics, which looks at structures and designs in the natural world in order to optimise the weight and aerodynamics of body constructions, for example. Last but not least, you can also do

your bit for TrueBlueSolutions by adapting your driving style.

For further information on our extensive package of measures, go to www.mercedes-benz.com/truebluesolutions

¹Provisional figures: combined fuel consumption: 5.9 l/100 km; overall CO₂ emissions: 157 g/km

The figures are not based on an individual vehicle and do not constitute part of the product offer; they are provided solely for purposes of comparison between different vehicle models

²TÜV SÜD Management Service GmbH, Munich



BlueTEC HYBRID. The Vision GLK 300 BlueTEC HYBRID¹ is the most efficient combination of BlueTEC diesel and hybrid modules



F-CELL. Emission-free mobility with the drive system of the future: the B-Class F-CELL goes into production in 2010

Refinement

Your invitation to embark on an extraordinary journey

Power in abundance! The V6 engine in the GL 320 CDI

The moment you step into the GL you'll realise you won't want to get out again in a hurry. Because yours is the best seat in the house – the one behind the wheel.

Now the moment you've been waiting for – opening the throttle for the first time. The GL 320 CDI is propelled by a mighty V6 diesel powerplant taken from the latest generation of engines. It employs the frugal common-rail direct injection principle with piezoelectric injectors for high-precision fuel metering and injection timing. Engine refinement has also undergone a number of advances compared to a conventional diesel unit; the chain routing has been optimised, for instance, resulting in yet smoother running, while noise levels have been subdued by the restyled engine cover.

All of which equates to exceptional performance: 165 kW (224 hp) are unleashed with dynamic yet controlled force. Just like its sibling in the GL 420 CDI, the engine naturally comes equipped with a particulate filter to meet the EU 4 emissions limits.

GL 320 CDI 4MATIC

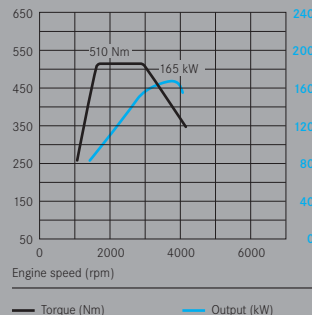

The GL 320 CDI boasts a remarkably uniform power delivery. Its peak torque of 510 Nm is fully available between 1600 and 2800 rpm







Your personal calling card: V8

Smoothness fused with dynamism: the V8 engines in the GL 420 CDI and GL 450

V8 denotes power and sheer driving pleasure in petrol and diesel engines alike.

A newly developed V8 diesel engine with a four-valve-per-cylinder design and common-rail direct injection is at work under the bonnet of the GL 420 CDI. 225 kW (306 hp) and 700 Nm of torque ensure distinctly sporty progress combined with respectable consumption figures.

The GL 450 boasts a V8 petrol engine that also features four valves per cylinder. Its 250 kW (340 hp) and maximum torque of 460 Nm make it a joy to drive anywhere you choose to go.

GL 420 CDI 4MATIC

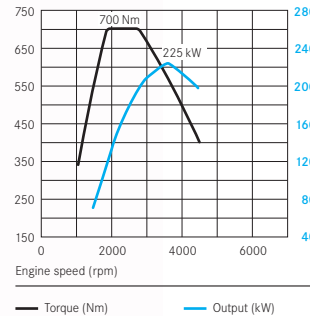

The GL 420 CDI delivers its maximum torque between 2000 and 2600 rpm

GL 450 4MATIC

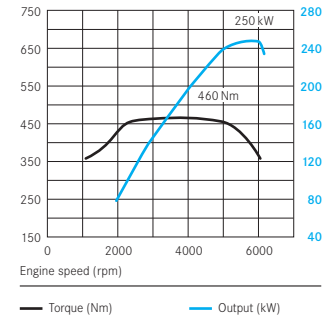

The GL 450 musters its maximum torque of 460 Nm at just 2700 rpm

Scaling new heights

The V8 engine powering the GL 500 maintains its maximum torque over a wide rev range

An engine of exceptional calibre lies in wait in the GL 500: a combination of four-valve-per-cylinder technology, optimisation of all air-ducting components and enlargement of the engine's displacement has resulted in a 26-percent increase in power output compared to the outgoing model – with virtually no impact on the fuel consumption figures. Put simply, you have 285 kW (388 hp) at the mercy of your right foot which will whisk the GL 500 from 0 to 100 km/h in just 6.5 seconds. And with torque delivery peaking at 530 Nm at just 2800 rpm, this engine is one of the most powerful, yet, at the same time, most economical drive units in its displacement category.

The cutting-edge aluminium and forged steel lightweight construction operates with special shifting camshafts which optimise the gas cycles in the engine. The discernible results are improved smoothness along with higher torque, particularly in the mid engine speed range. And it goes without saying that with two close-coupled catalytic converters, the GL 500 meets all existing emissions standards.

GL 500 4MATIC

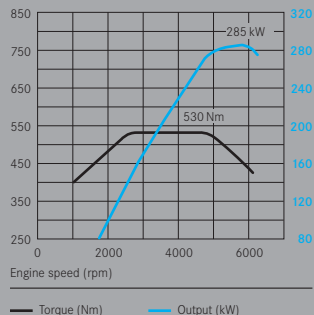

Torque peaks at just 2800 rpm and stays there all the way up to 4800 rpm





The best transmissions hardly make their presence felt

The 7G-TRONIC 7-speed automatic transmission

Pull away, accelerate, shift up, brake, shift down, speed away again ... and all with unerring smoothness. It's all down to the 7G-TRONIC intelligent automatic transmission's ability always to come up with the perfect gear selection to suit the current situation and your driving style.

The standard-specification 7G-TRONIC is designed for fuel-efficient, silky smooth operation. A total of seven ratios allow smaller steps between the gears, adding to the smoothness of the

GL-Class. And whenever you feel like stepping up the pace somewhat, the kickdown function slips into action: press the accelerator pedal down to its limit and the transmission instantly selects the optimum gear for maximum acceleration. It is even able to skip gears when downshifting for yet sharper acceleration response.

Should you wish, you are also able to change gear manually with the easy-to-use shift buttons on the back of the steering wheel spokes.

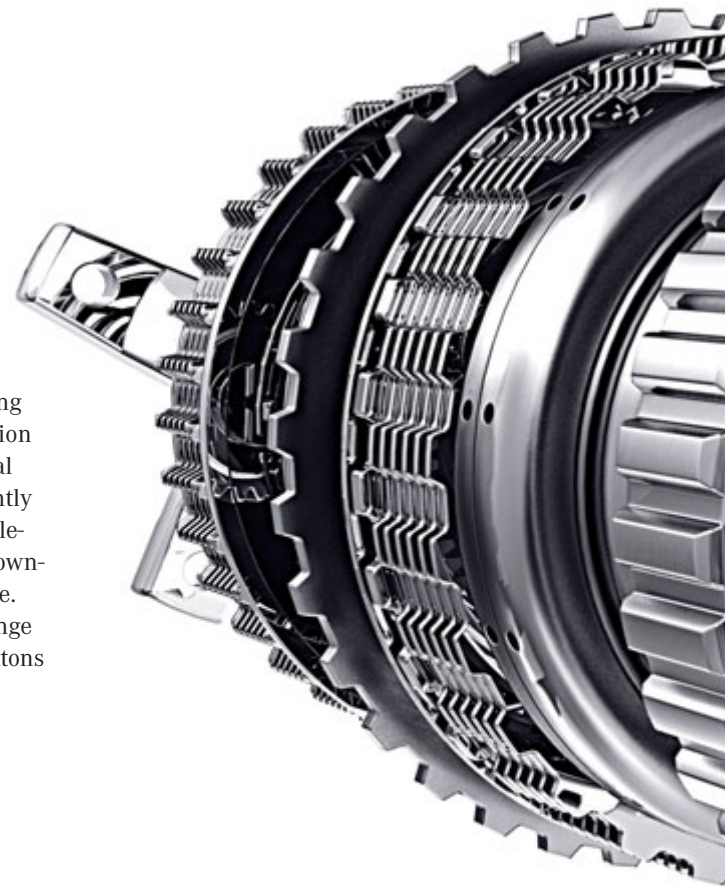

DIRECT SELECT

It seems a shame to clutter up the centre console with a selector lever. Which is why it's mounted directly on the steering column in the GL-Class, permitting fingertip selection of the D, R, N and P settings

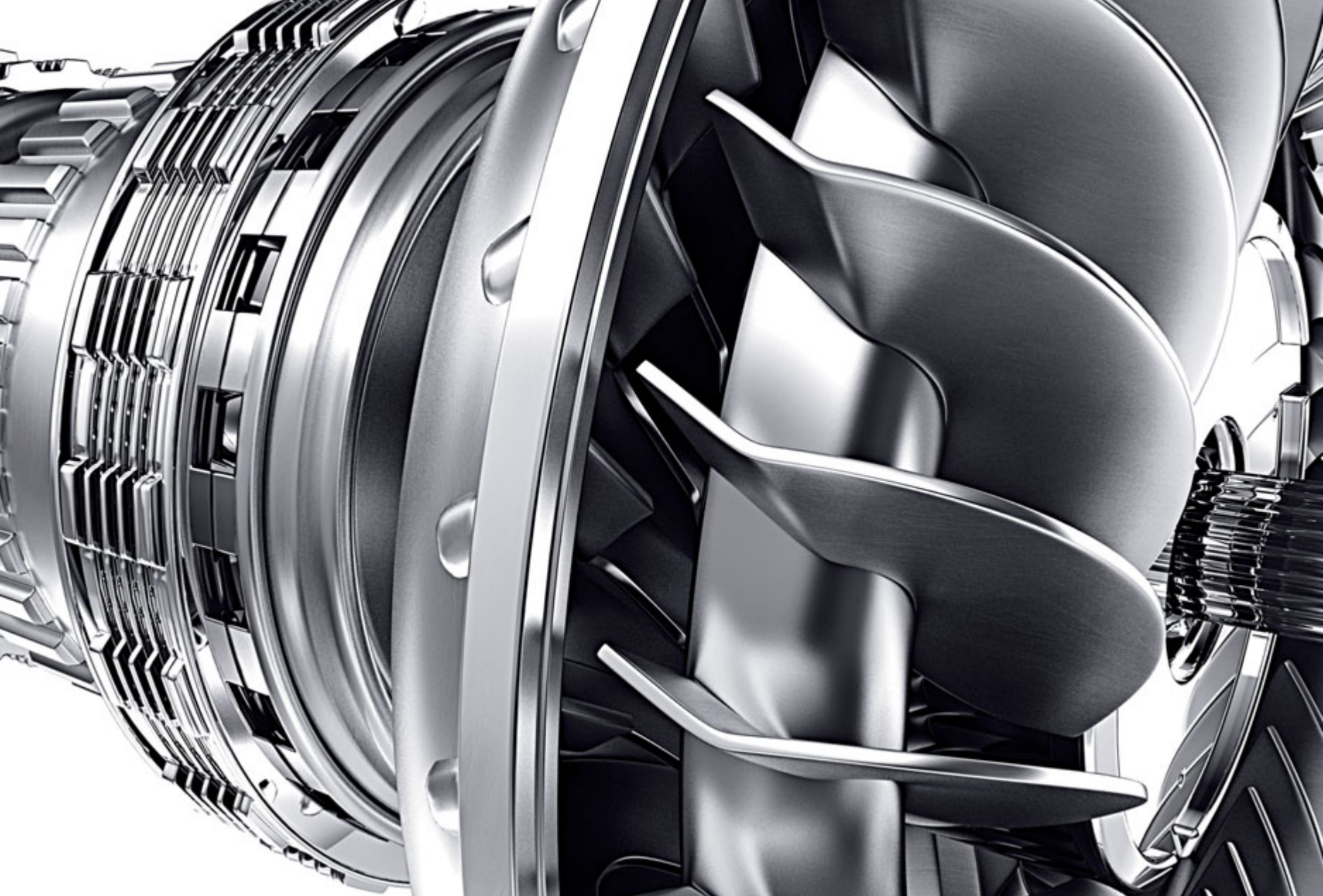



Off-road

When it's time to make tracks, why not drive down them instead?

From road to rough terrain – sheer pleasure with the GL

The GL is very much at home out on the open road, but it's also quite game for a foray off the beaten track.

The six-piece plastic underbody panelling of the GL-Class offers extra protection for driving in off-road terrain. The Off-Road Pro engineering package included as standard supplements this with a reinforced underguard at the front made from stainless steel. The fording depth can also be increased by 110 mm to a maximum of 600 mm, making light work of rocky stretches or stream crossings.

The double-wishbone suspension at the front and the four-link rear suspension, both of which come with self-supporting subframes, are ideally suited to the challenges of off-road driving. The isolated design of the subframes prevents any jolts from being transferred via the vehicle's body. The upshot is that rough terrain will be virtually imperceptible to you and your passengers, producing a ride that is almost as comfortable off the road as on it.





Go for it!

The Off-Road Pro engineering package readies your GL-Class for virtually any terrain. It has a maximum ramp angle of 23°



Ground clearance: up to 307 mm



Angle of approach / departure: max. 33° / 27°



Maximum fording depth: 600 mm



It is able to climb gradients of up to 100%, depending on ground conditions

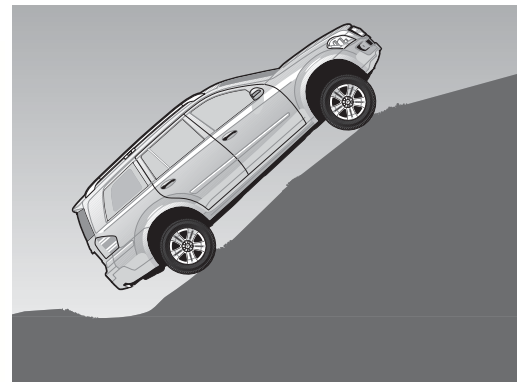

An off-road drive with an on-road feel

Extra reserves of safety in rough terrain: 4ETS and the low-range reduction gear ensure outstanding grip

The GL is an experience to savour on any road. However, the thrills don't really start until the tarmac stops. An array of technical features makes powering along muddy forest tracks nearly as effortless and comfortable as driving on the open road. Hill Start Assist comes to your aid on inclines, while off-road ABS reduces the stopping distance on descents, particularly on loose surfaces.

A two-speed transfer case is employed in the GL-Class. This allows you to switch from a higher on-road to a lower off-road ratio. This low-range

gear offers added power and improved traction on unpaved surfaces. Climbing steep slopes or pulling heavy loads becomes easier as a result. In off-road mode, the electronic dynamic handling control system 4ESP®/4ETS adapts to cater to the special conditions encountered in rough terrain: the timing of brake applications at the wheels is reprogrammed, for instance, and the 7G-TRONIC transmission's shift points are raised.

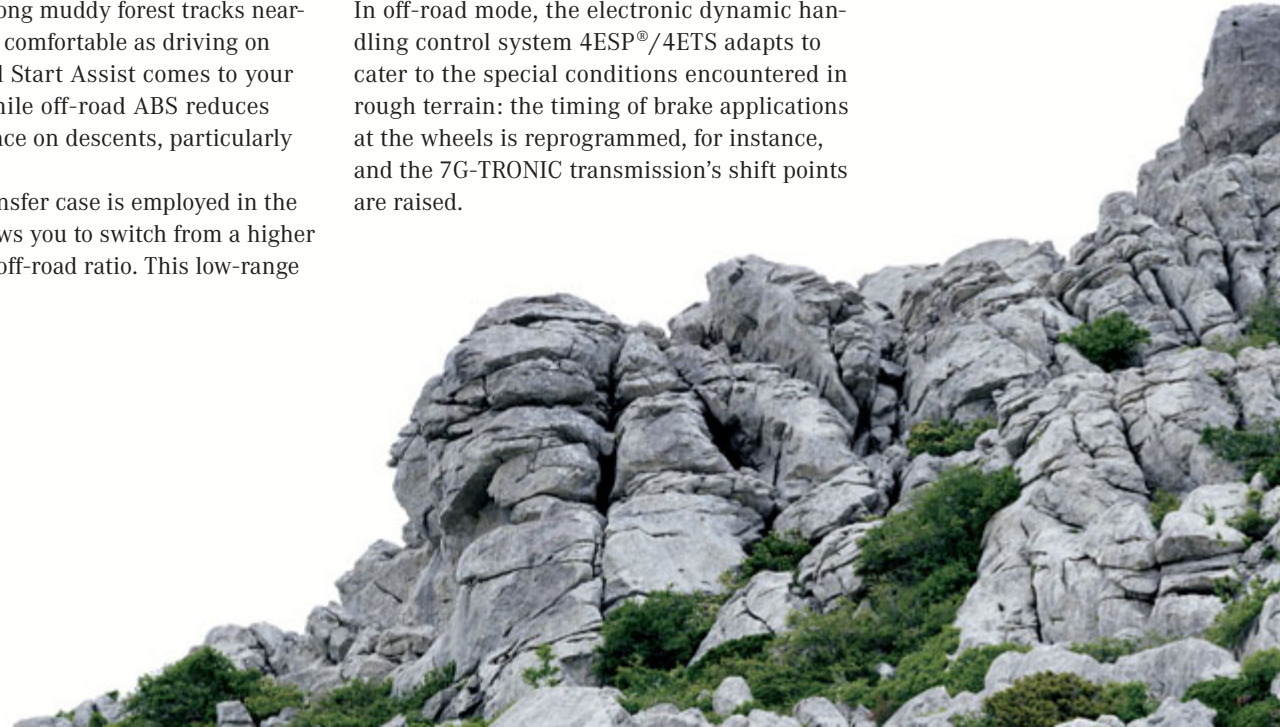







More comfortable than any boardroom seat

Finest wood and sumptuous leather – all you need for a very pleasant drive

The comfortable, elegantly styled seats are the most prominent feature of the interior. However, many of the more minor details are thoroughly deserving of your attention too: the wood trim is adorned in parts by chrome highlights and, depending on which leather upholstery version is specified, decorative topstitching lends further emphasis to the cockpit's attractive two-tone colour scheme.

The leather-trimmed multifunction steering wheel that comes as standard is also available in a heated or a wood/leather version as an option. All models come with speed-sensitive power steering. Plus, you are able to store your preferred steering wheel height setting with the memory package that is a standard feature (except in the GL 320 CDI).

The instrument cluster keeps you up-to-date with the most important data: the selected drive mode, for example, and the navigation commands or audio settings. Optionally, you can also choose to receive this information from COMAND APS: in this case the navigation or audio data appears in a colour display in the dashboard console. Pictures from the optional reversing camera, which teams up with PARKTRONIC to make light work of parking, are also shown here. Whatever you opt for, you'll be able to take everything in at a single glance.

Interplay of colours

The chrome highlights add a particular flair to the interior. With the alpaca grey and cashmere beige appointments, some details come in a two-tone finish, giving the cockpit a more spacious look







Being a leader is often a lonely task. But you can change that ...

The GL-Class comfortably seats up to seven

The best seat is reserved for you, the driver, but your fellow travellers are also in for a treat aboard the GL.

The driver and front passenger seats feature fully electric seat adjustment as standard. With the memory package (optional on the GL 320 CDI), the seat automatically moves into a position you have stored at the mere press of a button. The driver's seat features an integral electrically adjustable 4-way lumbar support which helps ensure a relaxed journey (GL 320 CDI). In addition, in the V8 models the multicontour seats are standard, offering even firmer lateral support while you're on the move. The standard of comfort is impressive in the second row of seats too: seat heating with a choice of three levels is available in conjunction with front seat heating and the backrest angle can be adjusted to four different positions.

The interior is kept at a pleasant temperature at all times by the automatic climate control THERMATIC or the luxury automatic climate control THERMOTRONIC, which is fitted in the V8 models and permits separate temperature control in the rear.

Fancy a challenge? Then try and fill the luggage compartment

EASY-PACK enables the ample luggage compartment to be packed with supreme ease

Family having trouble choosing what to take on holiday with them? Then just let them take everything! With a length of 5.08 m, a width of 1.92 m and a height of 1.84 m, there's space aplenty in the GL-Class.

The optional third row of seats can be accessed easily courtesy of the EASY-ENTRY system. Whenever you need extra luggage space, these seats can be simply folded away electrically. Likewise, the second row of seats can be folded flat too – leaving a whole 2300 litres of load space. Enjoy!

You can have all the hard work taken out of loading the vehicle by opting for the EASY-PACK system. The EASY-PACK tailgate opens and closes electrohydraulically and can be halted in any intermediate position to prevent it from knocking against low garage roofs, for example. Stowage capacity can be increased with an additional partitioned load compartment floor as well as a range of stowage boxes. And with the EASY-PACK load-securing kit, everything can be firmly lashed down and held in place, even when driving through off-road terrain.

The versatility of the GL-Class
With the optional third row of seats, the luggage compartment has a capacity of 300 litres. This increases to 1240 litres without the third-row seats.

Both of the rear rows of seats can be folded completely out of sight, producing a cavernous 2300 litres of load space

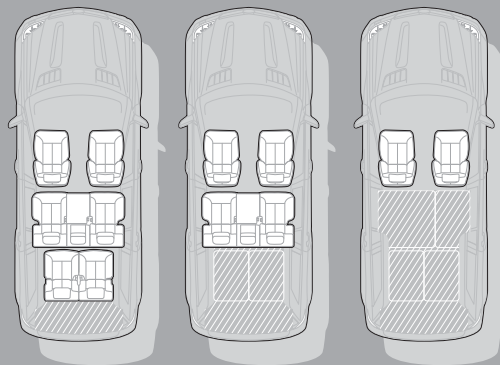







C.A.P.

Banca

A dark brown leather-bound book is shown at an angle, resting on a metallic surface. The book's cover is embossed with the text "THE INTEGRAL SAFETY CONCEPT" on the top line and "FROM MERCEDES-BENZ" on the bottom line. The book has visible stitching along its edges and a slightly worn, textured leather finish. The background is a brushed metal surface with some scratches and a soft shadow cast by the book.

THE INTEGRAL SAFETY CONCEPT
FROM MERCEDES-BENZ

A theory which can save lives in practice

The integral safety concept from Mercedes-Benz

If there is one area that drives us to ever greater achievements more than any other, it is researching new safety technologies. We laid the foundation for supreme standards of occupant protection back in the 1950s when Béla Barényi developed the passenger safety cell. The celebrated forefather of modern-day vehicle safety was not the only one to make his mark with groundbreaking ideas; there were others, too – such as Rolf Maier.

With a view to investigating the behaviour of the steering and restraint systems in an accident swiftly and cost-efficiently, Rolf Maier and his fellow engineers designed a special type of sledge, which was to be propelled at high speed against a wall. The engineers came up with a simple, yet highly ingenious solution for the crumple zone: gherkin cans from the factory canteen. This typifies the creative spirit that prevailed during those pioneering years.

Much as we like to reflect on the past, though, our focus has always been firmly on the future. The best example is our vision of accident-free

driving which is closer today than ever before thanks to the integral safety concept from Mercedes-Benz. This concept divides automotive safety into three phases. In the “safe driving” phase the car helps the driver to recognise, prevent and master critical driving situations. In the second phase, “in the event of danger”, PRE-SAFE® is capable of initiating various measures – depending on the equipment fitted and the situation concerned – to prepare the vehicle and its occupants for an impending accident. “In an accident” the occupants can be protected suitably and effectively by a comprehensive array of passive safety systems. Also very important is the fact that after an accident, too, a Mercedes is well prepared to provide help such as making it easier to rescue the occupants.

Further information about the Mercedes-Benz safety concept is available online at www.mercedes-benz.com/airbag-brochure





Complete peace of mind is the best method of accident prevention

Keeping relaxed at the wheel can nip danger in the bud

The majority of accidents start long before the actual collision: with a lapse in concentration, poor visibility or a hazard which is not recognised as such. The GL-Class is therefore fitted with safety equipment which promotes relaxed driving and helps you to cope with critical situations better.

Firstly, there is the ergonomically designed interior in which each switch and each function is easy to use. In addition, intelligent features such as the optional control and display system COMAND or the voice-operated control system

LINGUATRONIC (a component of COMAND APS and Audio 50 APS with a DVD changer) allow you to keep your hands on the wheel. Driver stress-relief also comes courtesy of the climate control system, comfortable seats and a fine-tuned suspension system.

Out on the road, more than 60 electronic aids are on standby, ready to either warn you as and when appropriate – such as the tyre pressure monitoring system – or actively come to your assistance. Leading the way is the Electronic Stability Program ESP®. Capable of stabilising

the vehicle when there is a risk of oversteer or understeer, this system received its premiere in a Mercedes. The braking systems featuring Brake Assist (BAS) are becoming increasingly versatile too: based on the speed with which you depress the brake pedal, BAS is able to detect emergency braking and instantly build up maximum brake pressure in response. The result: the vehicle comes to a stop sooner, perfectly mirroring the Mercedes-Benz safety philosophy of avoiding accidents before they even happen.

Trailer plus ESP[®] equals a winning team

Your invisible friends: safer driving in the GL

The Electronic Stability Program ESP[®] that is fitted as standard in the GL-Class supports the driver, while towing has now been made far safer thanks to the inclusion of a trailer stabilisation function.

Your field of vision is furthermore brightly illuminated at night by the projection-beam halogen headlamps which come as standard in the GL-Class. For even greater clarity of vision, bi-xenon headlamps with an active light function can be specified as an option. The active light function tracks the movement of the steering wheel, pivoting the headlamps to follow the line of the bend and improving illumination of the road ahead in the process by up to nearly 100%! When driving round a bend with a radius of 180 metres, for instance, the illuminated section of road is extended from approximately 30 to around 55 metres. During emergency braking the adaptive brake lights flash, thereby warning the drivers of vehicles behind.

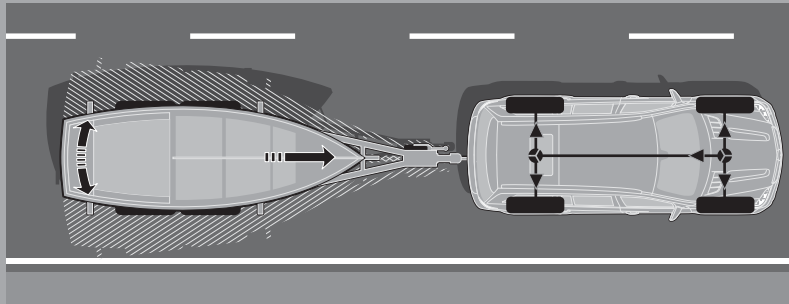

ESP[®] trailer stabilisation

There is a risk of trailers starting to swerve from side to side whilst being towed. The ESP[®] trailer stabilisation function is able to recognise this type of hazardous driving situation and immediately eliminate the weaving motion by briefly actuating the brakes





What do a few seconds matter? For Mercedes, they make the difference between an accident and outstanding accident protection

PRE-SAFE® can prepare the vehicle and the people inside it for an impending impact highly effectively

The unveiling of PRE-SAFE® from Mercedes-Benz in 2002 was prompted first and foremost by one simple observation: valuable seconds elapse unused between the detection of an imminent accident and the impact itself. PRE-SAFE® is able to use this time to great effect. The ESP® and BAS sensor system recognises critical driving situations, such as heavy oversteer or understeer, abrupt steering movements, as well as panic or emergency braking.

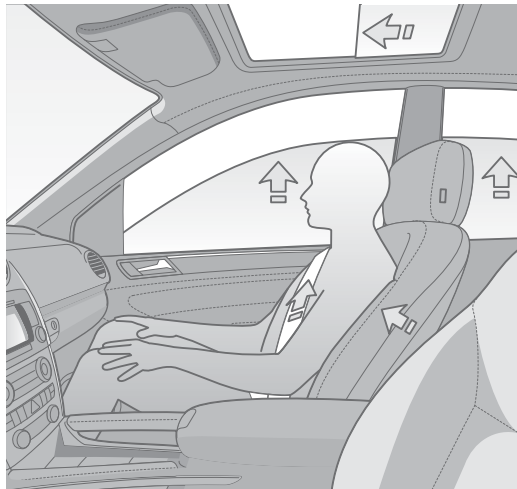

PRE-SAFE®
Helps ensure that a “moment of shock” remains nothing more than a moment: the anticipatory occupant protection system tensions the front seat belts and can – depending on the vehicle’s equipment and the driving situation – close the sun-roof and side windows, and move the front passenger seat into a more favourable position





PRE-SAFE® electronically evaluates this information and, if a typical pre-crash situation is identified, triggers precautionary measures to protect the occupants - the front passenger seat can be adjusted into a more favourable position (provided it is electrically adjustable and fitted with the memory function), the optional sunroof and the side windows can be closed and the front seat belts pulled taut.

In these various ways, PRE-SAFE® illustrates Mercedes-Benz's commitment to enhanced road safety based on innovative technologies.

When it comes to the crunch, a Mercedes-Benz is there to provide a soft landing

In an accident, the restraint systems and safety cell could save you and your passengers

Mercedes-Benz has been a pioneer in the field of passive safety from the outset. For example it introduced the first 3-point static seat belt in 1968.

The GL-Class of today, meanwhile, is equipped with a range of airbags, including two-stage airbags for the driver and front passenger and windowbags over all three rows of seats whose protection zone covers virtually the entire area of the side windows.

The sidebags and windowbags in the GL-Class also feature new deployment technology in the form of pressure sensors. If a door deforms due to an accident, the air pressure between the outer door panel and the interior of the door increases. This change is registered by the pressure sensors whose signals support the control unit's decisions concerning deployment of the sidebags and windowbags.











My GL-Class





Automatic wish fulfilment comes as standard

The standard equipment of the GL

The GL-Class comes with a wealth of creature comforts as standard, but the scope for personalisation is every bit as rich. Touches of chrome give the GL-Class an exclusive look, the Off-Road Pro engineering package gives it outstanding all-terrain capabilities and sophisticated functions such as the Audio 20 sound system, automatic climate control THERMATIC (GL 320 CDI) or (on vehicles with a V8 engine) luxury automatic climate control THERMOTRONIC combine to make travelling in the GL a truly indulgent experience and something to really savour.

When gold, silver or bronze just won't do ...

For that extra sparkle: the standard-fit basic chrome exterior package

Even in standard guise, the bold lines of the GL are set off by a number of chrome highlights. It starts right at the front, where the brilliant silver louvres of the radiator grille are embellished by chrome highlights, and continues through to the elegant chrome strips in the tail light units. The vehicle-coloured door handles feature a chrome insert, as does the tailgate handle. The rub strips at the side and the scratch guard on the rear bumper likewise sport a gleaming chrome finish. The touches of chrome form an appealing contrast with the black used for other parts, such as the roof rails, the panelling for the B and C-pillars as well as the roof edging and waistline trim (waistline trim chrome-coloured on all V8 models).

Optical trinity: red and white lights plus chrome inserts



The tailpipes in high-shine stainless steel



Door handle with chrome insert





Always ready for a trip into off-road territory



Taking the rough with the smooth

The Off-Road Pro engineering package: leaves virtually any track powerless to resist

The Off-Road Pro engineering package that comes as standard transforms your luxurious GL into a fully fledged cross-country vehicle. Features include a two-speed transfer case which allows you to switch between an on-road and an off-road ratio. The off-road mode's low-range gear has a shorter ratio, meaning added power and superior traction, particularly when tackling steep slopes and treacherous tracks or pulling heavy loads. The AIRMATIC air suspension offers a choice of three ride levels, allowing you to adjust the ground clearance of your GL to suit your requirements, while the firmness of the damping can be varied between comfortable and sporty by means of the Adaptive Damping System ADS. Forging depth can be increased to as much as 600 mm.

Protection for your GL during off-road trips: the simulated underguard made from stainless steel



Get ready for a day in the countryside at the push of a button



Stylish and sophisticated – right down to the finest detail

Information, relaxation, pleasure: inside the GL, anything's possible

The instrument cluster's multifunction display keeps you up-to-date with everything you want to know during the journey, such as the selected drive mode or the outside temperature, for example. Additional data can be called up at the push of a button: navigation displays, telephone settings, audio data, off-road displays illustrating the air suspension's current ride height or a compass. There's no shortage of relaxation features either, however: the automatic climate control THERMATIC (the luxury automatic climate

control THERMOTRONIC on V8 models) keeps the interior at your ideal temperature, the Audio 20 sound system with a total of eight speakers and a CD player allows you to relax to your favourite music and the lighting package (which is only available as standard in conjunction with leather) gives the interior an extra cosy feel. Reading lamps for the first two rows of seats are complemented by indirect illumination of the glove compartment and centre console.

The instrument cluster tubes sport chrome surrounds with a matt finish



Always to hand: twin cup holder



Making a clear-cut impression: the interior's two-tone colour scheme



The GL is a car of many virtues, but its true talent lies in its ability to thrill

The standard equipment at a glance

The 6 and 8-cylinder engines, the smooth 7G-TRONIC automatic transmission, the speed-sensitive power steering, AIRMATIC air suspension and the DIRECT SELECT gearshift with convenient steering-wheel shift buttons turn every trip in the GL into a pleasure ride. And there's more besides: the Electronic Stability Program ESP®, airbags plus belt tensioners and belt force limiters included with certain seat belts all combine to enhance safety.

The interior invites you to really make yourself at home. The GL-Class is equipped with electrically adjustable seats upholstered in ARTICO man-made leather as standard (nappa leather in the GL 500). The picture is otherwise dominated by fine woods and a harmonious two-tone colour scheme set off by touches of chrome. The glass roof extending over the optional third row of seats allows extra light to flood in, and the load compartment behind the front seats has a capacity of up to 2300 litres.

The Audio 20 sound system display



The off-road display in the instrument cluster



Adjust the differential locks with a mere flick of the wrist



STANDARD EQUIPMENT (SELECTION)

19-inch light-alloy wheels (18-inch in GL 320 CDI)
3-point seat belts (at front with adaptive belt force limiters, belt buckle tensioners and manual belt height adjustment; 3-point seat belts for outer seats on 2 nd seat row with integrated belt tensioners and belt force limiters)
4ESP®/4ETS (Electronic Stability Program and Electronic Traction System)
7G-TRONIC 7-speed automatic transmission
Adaptive Damping System (ADS) with three setting ranges
Airbags with multi-stage deployment logic and sidebags for driver and front passenger, plus windowbags for all seat rows
AIRMATIC (air suspension with level control all round)
Anti-lock braking system (ABS)
Armrests front and rear, folding, front armrest with compartment
ARTICO man-made leather (nappa leather in GL 500)
ASSYST PLUS service interval indicator with service computer
Audio 20 with CD player
Aux-in connection in the glove compartment, for external audio devices
Basic chrome exterior package (brilliant silver radiator grille with chromed highlights, chrome inserts in tail lights, vehicle-coloured door handles with chrome inserts, chrome finish for tailgate handle, chrome-look side rub strips and scratch guard on rear bumper)
Brake Assist (BAS)
Central locking with interior switch and crash sensor
Cruise control with SPEEDTRONIC variable speed limiter
Dashboard and door centre panels trimmed in ARTICO man-made leather
DIRECT SELECT gearshift with steering-wheel gearshift buttons and steering-column selector lever
Downhill Speed Regulation (DSR – automatic brake control for downhill driving)
Driver's seat with electric 4-way lumbar support (for GL 420 CDI)
Electronic immobiliser incl. locking system with radio/infrared remote control (recognised by AZT (Allianz Technology Centre) and German Technical Inspection Authority)

Electronic Stability Program ESP® with ABS and ASR
Front right and left multicontour seats (for GL 420 CDI, GL 450 and GL 500)
Green-tinted, noise-insulating glass all round
Headlamp Assist
Hill Start Assist
ISOFIX child seat attachment points for 2 nd seat row, left and right, with TopTether, left, centre and right
Leather-trimmed multifunction steering wheel
Load-securing rings in load compartment
Memory package in front (fully power-adjustable front seats)
NECK-PRO crash-responsive head restraints for driver and front passenger
Off-Road Pro engineering package (two-speed transfer case, additional differential locks, modified air suspension with extendable range for greater ground clearance and fording depth, reinforced underguard)
Power windows (4)
PRE-SAFE® (initiates preventive occupant protection measures as a precaution in critical driving situations)
Rear panoramic roof
Roof rails in black
Simulated underguards in chrome-look stainless steel front and rear (optional extra for GL 320 CDI as part of the exterior chrome package)
Speed-sensitive power steering
THERMATIC automatic climate control (in GL 320 CDI)
THERMOTRONIC luxury automatic climate control (optional for GL 320 CDI)
Tyre pressure loss warning system
Waistline trim strip in chrome (for GL 420 CDI, GL 450 and GL 500)



Perfect for the car that has everything

The changing faces of the GL

Would you like to add an extra touch of allure to your GL with stunning light-alloy wheels? The GL 320 CDI rides on 18-inch 5-spoke light-alloy wheels measuring 265/60 R 18 as standard, while the V8 models sport 19-inch light-alloy wheels in a 5-twin-spoke design (optional for GL 320 CDI). The list of optional extras for all models includes the distinctly styled 20-inch 5-spoke light-alloy wheel with dimensions of 275/50 R 20. The elegant incenio “Aldhanab” 19-inch designer wheel in a 7-spoke design and the imposing incenio “Tyndarides” 20-inch 5-spoke designer wheel can be chosen from the accessories range for any model.

Optionally, for an even brawnier look, you can fit your GL with 21-inch AMG 5-spoke light-alloy wheels (option includes flared wheel arches).

21-inch AMG 5-spoke light-alloy wheel

18-inch 5-spoke light-alloy wheel



incenio "Aldhanab" 19-inch 7-spoke designer wheel



19-inch 5-twin-spoke light-alloy wheel



incenio "Tyndarides" 20-inch 5-spoke designer wheel



Turn something beautiful into something irresistible

The exterior chrome package gives the GL even greater presence

There are so many different types of chrome highlights. We've taken a few and transformed them into stunning design details. On models with the optionally available exterior chrome package, the roof rails gleam in chrome instead of black. Waistline trim strips in chrome, together with simulated underguards front and rear, are also included in the package (standard on

V8 models). If the optional bi-xenon headlamps are specified, the front fog lamps come with a chrome surround. And should you wish to further emphasise the GL's elongated flanks, there is the option of running boards. As a further optional extra, chrome crossbars are also available.

Standard on all V8 models, part of the exterior chrome package for the GL 320 CDI: the simulated underguards at the front and rear



The radiator grille with louvres in a brilliant silver finish along with the optional running boards give the GL a bold look



Light is so common. Let us turn it into something really special

The optional extras for the GL-Class

The GL is glazed with green-tinted glass as standard. Should you prefer a little more privacy, you can opt for heat-insulating, dark-tinted glass, in which case it will not be possible to see through the rear window, the rearmost side windows or the rear door windows from the outside. This option can also be combined with heat-insulating, infrared-reflecting glass. This glass cuts the amount of heat radiated through the front side windows by around 60 percent, keeping the temperature inside the vehicle at a far more pleasant level. Lighting levels inside the GL remain unaffected by this particular option, but can be enhanced if desired by the addition of the optional lighting package (in conjunction with leather upholstery), comprising features such as reading lamps above the third row of seats and illuminated cup holders.

The GL-Class comes with a panoramic roof in the rear as standard. For an even brighter interior, there is the option of an electric tilting/sliding glass sunroof at the front, featuring an inner liner that can be slid into any position manually to shield the occupants from the sun's rays.





The clearly structured COMAND APS display in the dashboard console



Taking the right decision depends on having all the right information to hand

COMAND APS gives you the full picture

COMAND APS with its 6.5-inch colour display informs you in even greater detail than the instrument cluster is able to. COMAND APS includes a navigation computer. Special characteristics of this new generation feature include: rapid hard-disc navigation and the particularly clear and realistic bird's-eye-view display graphics.

The practical reversing camera doesn't just take the hard work out of parking, it also comes to your aid when manoeuvring in difficult off-road terrain.

The wide-angle camera is attached to the tailgate and is actuated when reverse gear is engaged. It monitors the area immediately behind the vehicle in the form of a video picture in the COMAND display, offering you an unobstructed view at all times. PARKTRONIC, which comes as standard on the GL 500, is another convenience-enhancing feature. Its sensors operate at road speeds of up to 16 km/h and issue visual and audible signals to warn the driver of any obstructions.

The reversing camera makes light work of manoeuvring safely



Sounding an end to “Are we nearly there yet?”

Non-stop distraction of the highest calibre: the in-car entertainment systems

Enjoy front-row viewing from second-row seats: 8-inch colour screens can be optionally incorporated into the back of the front-seat head restraints. Apart from this, each monitor also includes a set of wireless headphones and a remote control. Under the seat cushion of the second row of seats can be found a DVD player, while the TV tuner is capable of receiving both analogue and digital signals (DVB-T). The entertainment line-up is rounded off by pre-installation for a mobile phone, a CD changer as well as connections for games consoles. So now, there’s really no excuse for anyone to feel bored.

The monitors can be used for playing DVDs, digital camera recordings or games

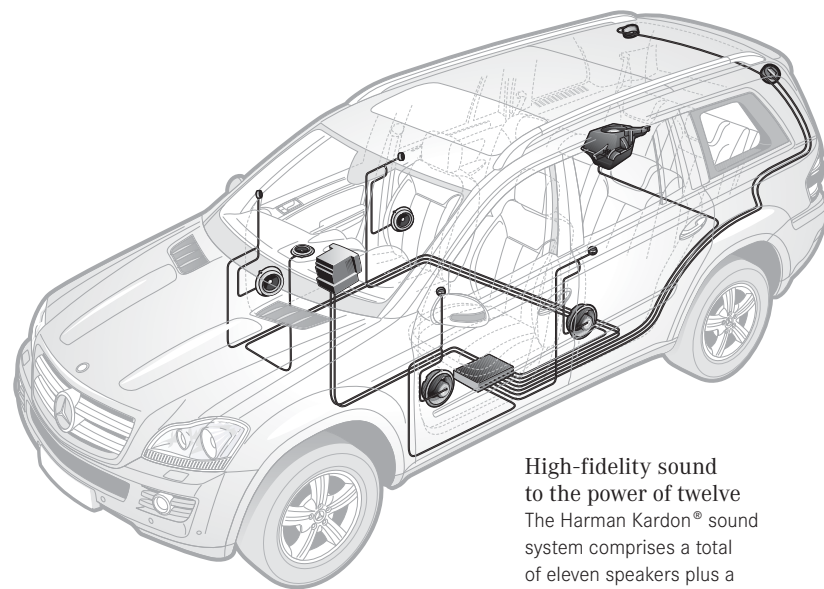

**High-fidelity sound
to the power of twelve**
The Harman Kardon® sound
system comprises a total
of eleven speakers plus a
subwoofer for all-round
surround sound

8-inch colour screens can be integrated into the back of the front head restraints as an option



Twists and turns only make their presence felt at the steering wheel

For a whole new seating sensation: the multicontour seat

The driver and front passenger both benefit from the heated multicontour seats as standard in the V8 models. Individual air chambers are distributed throughout the seat, which you are able to adjust as desired. The chambers in the lumbar region, the backrest side cushions and the front seat cushion are inflated to a higher pressure for extra stability. Meaning that your body will hardly be able to tell the difference between the twisty and the straight bits.

The optional climatised seating function makes a great contribution to comfort. Not only does this function make for pleasant seat climate control, it can cool down hot seat surfaces more swiftly in the summer or, in conjunction with the seat heating, it can dry out damp clothes faster – just what you need if you're venturing off the beaten track.

The seats in the GL-Class are electrically adjustable as standard. Extra convenience comes in the form of the memory package (standard in the V8 models) that stores not just the selected seat position but the steering column and exterior mirror settings too. The same package also incorporates a handy easy-entry/exit feature and power adjustment of the head restraint height.

Comfort at the push of a button

The memory buttons are placed where they can be easily reached on the outside of the seat. All your personal settings can be restored at the mere push of a button



Multicontour seats in black leather for driver and front passenger



<i>OPTIONAL EXTRAS (SELECTION)</i>	<i>GL 320 CDI 4MATIC</i>	<i>GL 420 CDI 4MATIC</i>	<i>GL 450 4MATIC</i>	<i>GL 500 4MATIC</i>
Automatically dimming interior and exterior mirrors	●	□	□	□
Auxiliary heater with remote control	●	●	●	●
Bi-xenon headlamps with active light function, headlamp cleaning system, dynamic headlamp range control, cornering light function and integral fog lamp function	●	●	●	□
Chrome crossbars	●	●	●	●
COMAND APS multimedia system with 6.5-inch colour display	●	●	●	●
Dark-tinted privacy glass for rear window and rear side windows	●	●	●	●
Electrically operated tilting/sliding glass sunroof and electrically operated rear side vent windows	●	●	●	●
Exterior chrome package (chrome-look roof rails; for the GL 320 CDI, chrome waistline trim strips and stainless steel, chrome-look simulated underguards front and rear are also included)	●	●	●	●
Garage-door opener in interior mirror	●	●	●	●
Harman Kardon® Logic 7® surround sound system, Dolby Digital 5.1, DTS, 11 loudspeakers plus subwoofer, 610-watt	●	●	●	●
Heated leather steering wheel	●	●	●	●
KEYLESS-GO	●	●	●	●

Bi-xenon headlamps with active light function enhance illumination of the road ahead



The electrically operated EASY-PACK power tailgate is standard for the GL 500



<i>OPTIONAL EXTRAS (SELECTION)</i>	<i>GL 320 CDI 4MATIC</i>	<i>GL 420 CDI 4MATIC</i>	<i>GL 450 4MATIC</i>	<i>GL 500 4MATIC</i>
Leather upholstery (including interior lighting package)	●	●	●	–
Memory package (front seats, steering column, head restraint height and exterior mirrors electrically adjustable, exterior mirror with parking position)	●	□	□	□
Nappa leather upholstery (including interior lighting package)	●	●	●	□
Outboard spare wheel carrier ¹	●	●	●	●
PARKTRONIC	●	●	●	□
Rear air conditioning (only in conjunction with THERMOTRONIC)	●	●	●	●
Rear seat entertainment system with two LCD screens (8-inch), DVD player and wireless headphones	●	●	●	●
Reversing camera	●	●	●	●
Tailgate (electrically operated with load-securing kit) incl. obstruction sensor	●	●	●	□
TV tuner for analogue and digital TV reception (only in conjunction with COMAND APS)	●	●	●	●
Wood/leather steering wheel	●	●	●	●

● Optional extra

□ Standard equipment

– Not available

¹ Not in conjunction with 21-inch AMG 5-spoke light-alloy wheels, Minispare wheel and reversing camera

The wood/leather steering wheel makes driving all that more pleasurable



The luxury automatic climate control THERMOTRONIC is individually programmable



Protective side bar with integral step



Screen for rear seat entertainment system



More comfort, more stowage space – more personality

The genuine accessories offer you even greater scope for personalising your GL

Space is one luxury you can never have too much of. The roof box comes in a titanium metallic or a matt silver finish and is available in a choice of three sizes, with capacities ranging from 330 up to 450 litres. The new crossbars offer sturdy support for the New Alustyle ski and snowboard racks as well as the Mercedes-Benz roof boxes. And even when their load-carrying abilities are not needed, they emphasise the sporty lines of your GL-Class.

The protective side bars made from electro-polished stainless steel lend particular emphasis to the vehicle's profile, and their integral plastic steps make it simpler to get in and out of the vehicle or load the roof rack.

You can now enjoy complete control over the music played in the car. The iPod® Interface Kit mounted in the glove compartment allows you to link up your iPod® with the audio system and operate it from the multifunction steering wheel. The state-of-the-art rear seat entertainment system can be housed between the front seats and comes complete with remote control. The system includes a DVD player, a high-resolution 8-inch LCD colour screen and two sets of headphones – ensuring that passengers in the rear are in for a thrilling drive too.

The roof boxes for the GL are available in three different sizes and two colours



Chromed door handle recesses ensure a glittering entrance







Colours and materials

Irresistibly stunning. And stunningly resistant

A clearcoat with a difference

1934. The first “Silver Arrow” is probably the only Mercedes-Benz ever to have started out in life with less-than-perfect paintwork. When the Mercedes-Benz engineers put the newly developed W 25 racing car on the scales during scrutineering before the Eifel Grand Prix at the Nürburgring in 1934, the 300-hp car turned out to weigh 751 kilograms – just one kilogram over the strict weight limit imposed by the international racing federation. “Well, that takes the shine off things,” mused Mercedes racing manager Alfred Neubauer – then realised he’d just put his finger on the solution. He promptly ordered the engineers to sand down the white paintwork, thus exposing the silver-coloured aluminium bodywork. This shed the necessary weight and the rest is history: Manfred von Brauchitsch won the race and it wasn’t long before the press were raving about the “Silver Arrows”, as they quickly dubbed them.

2006. If they had been faced with today’s latest-generation paint from Mercedes-Benz, the “Silver Arrow” engineers would have had their work cut out. Quite simply because the special paint finish developed by Mercedes-Benz is significantly more durable than previous clearcoats, producing a longer-lasting, more intense shine. Regardless of whether the final finish is non-metallic or metallic, the clearcoat is less vulnerable to scratching and also less sensitive to climatic and environmental influences, such as precipitation, sunlight, fluctuating temperatures, dust or soot.

Expressive colours

Bring out the character of the GL-Class with your favourite colour. Choose from a range of different paint finishes and continue the theme inside, where fine leather and colour-coordinated woods round off the look of your GL-Class

NON-METALLIC PAINTS

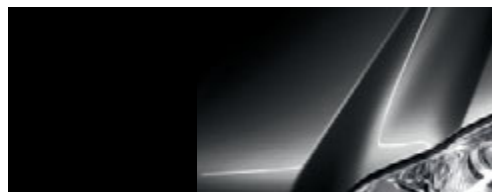

040 black



650 calcite white

METALLIC PAINTS

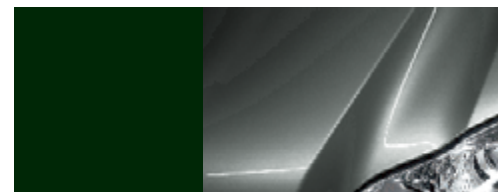

197 obsidian black



300 periclase green



359 tanzanite blue



544 carneol red

METALLIC PAINTS



723 cubanite silver

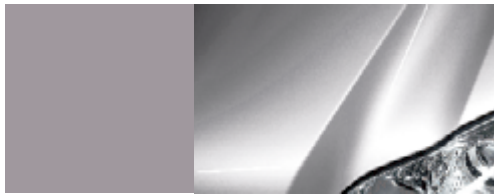

775 iridium silver



798 sanidine beige

SPECIAL PAINT

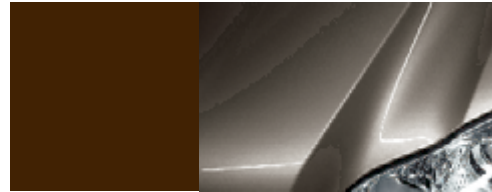

474 peridot brown

Take a seat

Finest leather sets the tone inside the GL-Class. You won't find a more comfortable or refined place to sit. Try it out for yourself

ARTICO MAN-MADE LEATHER¹

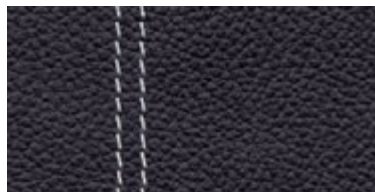

101 black⁴

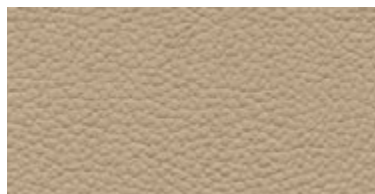

104 cashmere beige

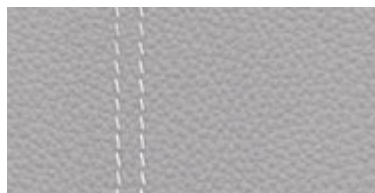

108 alpaca grey⁴

LEATHER²

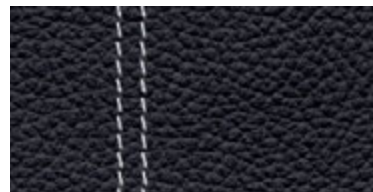

201 black⁴

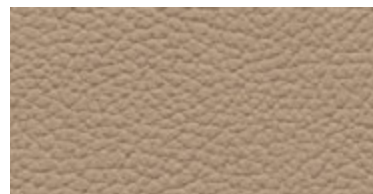

204 cashmere beige

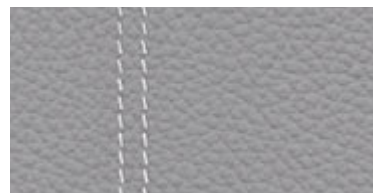

208 alpaca grey⁴

NAPPA LEATHER³

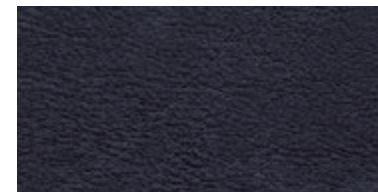

501 black

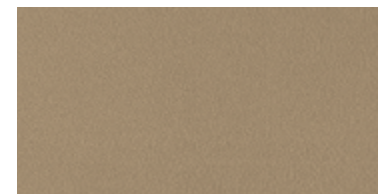

504 cashmere beige



508 alpaca grey

¹ Standard for GL 320 CDI, GL 420 CDI, GL 450

² Optional extra for G 320 CDI, GL 420 CDI, GL 450

³ Optional extra (standard for G 500)

⁴ Topstitching in contrasting colour

The ideal way of getting more in touch with nature

Wood and leather turn your GL into something really special

Two materials serve to remind you that the GL is a country dweller at heart: leather and wood.

The seats in the GL 500 are upholstered in soft nappa leather. Nappa leather is produced when leather skins of varying thicknesses are split into even layers. The nappa leather is the high-grade topmost layer, characterised by exceptional suppleness and smoothness.

The wooden trim adds a very special something too. Pale birch with chrome highlights features as standard in the GL 500 and is available as an optional extra for the other models. What sets this finish apart from other wood inlays is the soft, unpainted surface. The wood's natural porosity has been preserved, as you will notice when you run your fingers along it.

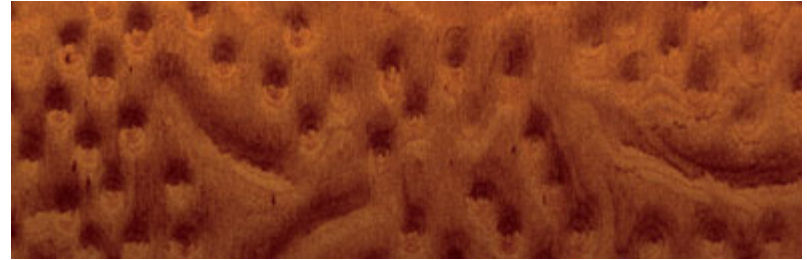

Bird's-eye poplar wood¹

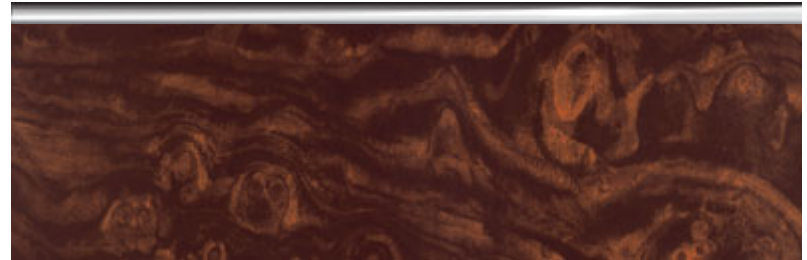

Burr walnut with chrome highlights²



Pale birch with chrome highlights³

¹ For GL 320 CDI only

² Standard for GL 420 CDI and GL 450, no-cost option for GL 500

³ Standard for GL 500

	ARTICO MAN-MADE LEATHER			LEATHER			NAPPA LEATHER		
	black	cashmere beige	alpaca grey	black	cashmere beige	alpaca grey	black	cashmere beige	alpaca grey
NON-METALLIC PAINTS									
black	●	●	●	●	●	●	●	●	●
calcite white	●	○	●	●	○	●	●	○	●
METALLIC PAINTS									
obsidian black	●	●	●	●	●	●	●	●	●
periclase green	●	●	○	●	●	○	●	●	○
tanzanite blue	●	○	●	●	○	●	●	○	●
carneol red	●	○	●	●	○	●	●	○	●
cubanite silver	●	△	●	●	△	●	●	△	●
iridium silver	●	○	●	●	○	●	●	○	●
sanidine beige	●	●	△	●	●	△	●	●	△
SPECIAL PAINT									
peridot brown	●	●	○	●	●	○	●	●	○

● Recommended ○ Possible △ Not recommended



	<i>GL 320 CDI 4MATIC</i>	<i>GL 420 CDI 4MATIC</i>	<i>GL 450 4MATIC</i>	<i>GL 500 4MATIC</i>
No. of cylinders/arrangement	6/V	8/V	8/V	8/V
Bore/stroke (mm)	83.0/92.0	86.0/86.0	92.9/86.0	98.0/90.5
Total displacement (cc)	2987	3996	4663	5461
Rated output ¹ (kW at rpm)	165/3800	225/3600	250/6000	285/6000
Rated torque ¹ (Nm at rpm)	510/1600–2800	700/2000–2600	460/2700–5000	530/2800–4800
Compression ratio	17.7	17.0	10.7	10.7
Alternator (V/A)	14/220	14/220	14/180	14/180
Acceleration from 0 to 100 km/h (s)	9.5	7.6	7.2	6.5
Top speed, approx. (km/h)	210	230	235	240 ²
Tyre size				
front	265/60 R 18	275/55 R 19	275/55 R 19	275/55 R 19
rear	265/60 R 18	275/55 R 19	275/55 R 19	275/55 R 19
Fuel	Diesel	Diesel	Premium unleaded	Premium unleaded
Fuel consumption ³ (l/100 km)				
urban	12.3–12.9	15.6–16.0	18.0–18.2	18.4–18.6
extra-urban	8.2–8.3	9.2–9.4	10.3–10.5	10.4–10.6
combined	9.7–10.0	11.6–11.8	13.1–13.3	13.3–13.5
CO ₂ emissions ³ (g/km), combined	257–264	307–313	312–317	317–322
Tank capacity (l)/of which reserve approx.	100/13	100/13	100/13	100/13
Turning circle (m)	12.1	12.1	12.1	12.1
Load capacity behind driver's seat without 3 rd seat row, 2 nd seat row folded down (l)	2300	2300	2300	2300
Kerb weight ⁴ (kg) (7 seats)	2450 (2505)	2550 (2585)	2430 (2465)	2445 (2480)
Permissible GVW (kg) (7 seats)	3150 (3250)	3250 (3250)	3150 (3250)	3150 (3250)

¹ Figures according to Directive 80/1269/EEC in the currently applicable version

² Electronically governed

³ The figures shown were obtained in accordance with the prescribed measuring processes (Directive 80/1268/EEC in the currently applicable version).

The figures are not based on an individual model and do not constitute part of the product offer; they are provided solely for purposes of comparison between different vehicle models

⁴ Figures according to Directive 92/21/EC, version 95/48/EC (kerb weight with fuel tank 90% full, driver, 68 kg, and luggage, 7 kg) for standard-specification vehicles.

Optional extras and accessories will generally increase this figure and reduce the payload capacity accordingly

The GL-Class

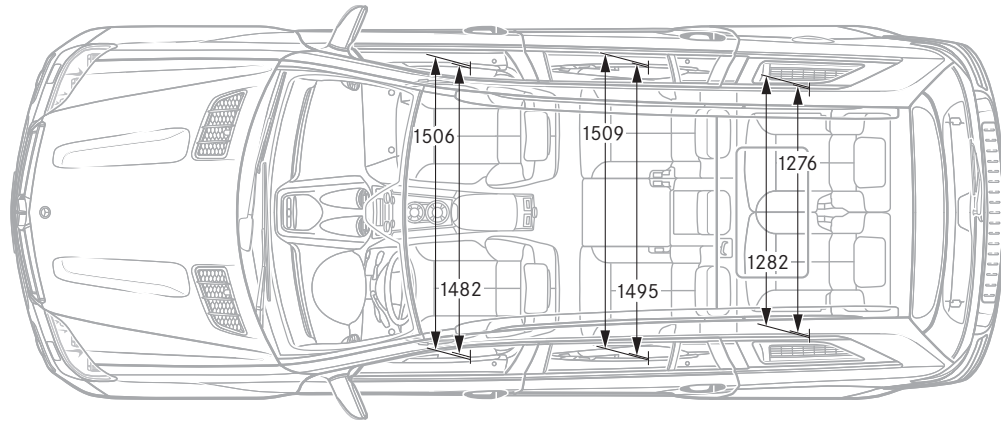
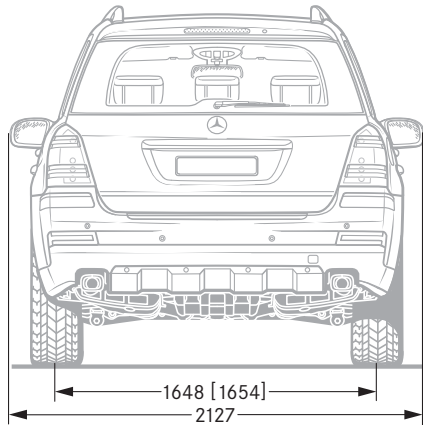
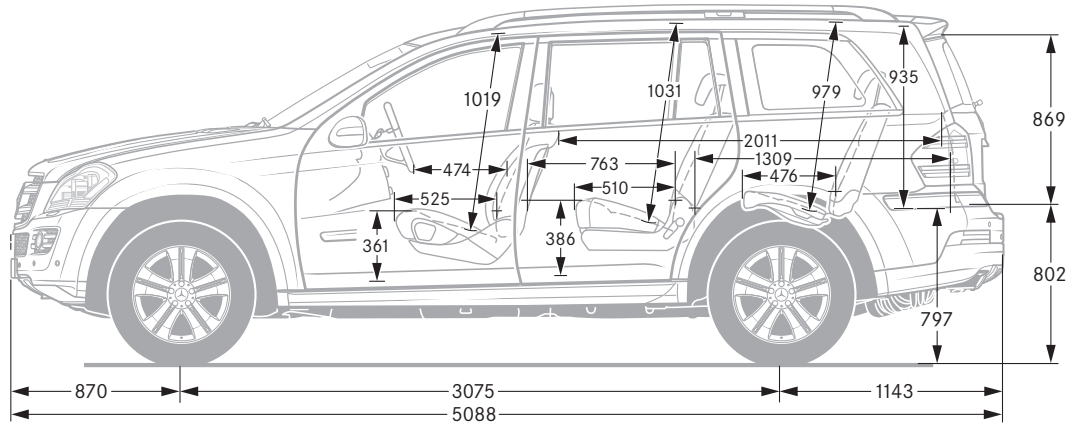
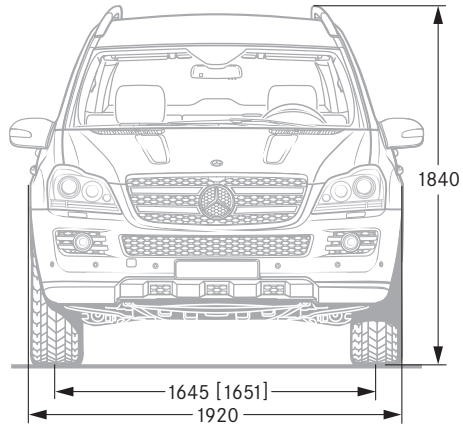

All measurements in millimetres. The dimensions shown are mean values and apply to standard-specification, unladen vehicles

[] Figures for GL 320 CDI

Anyone opting for a Mercedes buys far more than just a car

Comprehensive service offered by Mercedes-Benz

Mercedes-Benz for you

It all started in Berlin at the end of 2000: the concept of the car dealership was reinvented with the opening of the first Mercedes-Benz Centre. Featuring the entire Mercedes-Benz model line-up as well as the accessories range, brand merchandise and an attractive programme of events, the Centres offer a welcoming environment in which to experience the brand at first hand.

But it's not just in major cities that you can experience the legendary Mercedes-Benz brand and service. A close-knit network of company-owned branches and authorised dealers ensures that you are never far from the wide range of services, the comprehensive customer care and the high quality which you expect from Mercedes-Benz. And you can count on their support at every stage – before you buy your Mercedes, during the purchase process and, most importantly, for a long time afterwards, too.

Mercedes-Benz Museum

More than 120 years of automotive history in one place – this is what awaits you at the Mercedes-Benz Museum in Stuttgart. Experience the unique excitement first hand, and embark upon a thrilling journey through time. Housed inside an architecturally impressive building, over 1500 exhibits on nine levels give you an insight into the unique tradition and powers of innovation of the Mercedes-Benz brand. Plus you can see the world's first two automobiles in the shape of the Benz Patent-Motorwagen (motor car) and the Daimler motorised carriage – both from the year 1886. Two linked circuits take you from the beginnings of the automobile, past a series of unforgettable classics, through 100 years of motor-racing history and, finally, on to a glimpse of what the future holds – all in an area covering a total of 16,500 square meters. Enjoy the unique brand experience. We look forward to your visit.

MercedesCard

Your ticket to the Mercedes-Benz experience: the quarterly MercedesCard ARGENTUM journal offers you an exclusive selection of exciting events starring the Mercedes-Benz brand. In addition, the Mercedes magazine is packed with gripping and inspiring articles and reports. The MercedesCard has many other functions: as a VISA credit card, it is an accepted form of payment worldwide – with no annual fee if you complete a questionnaire every year. In addition, it offers further benefits to put your mind at ease, such as the Mercedes-Benz insurance package, at no extra charge, and the exclusively compiled MercedesCard insurance package at a preferential rate. For further information about this offer, available exclusively to Mercedes-Benz drivers, visit www.mercedes-benz.de/mercedescard¹

¹ Information about the MercedesCard in Austria and Switzerland can be found on the Mercedes-Benz websites for these countries

Mercedes-Benz Service24h

The feel-good factor, which kicks in when you sit behind the wheel of your new Mercedes for the first time, is further enhanced by the knowledge that Mercedes-Benz Service24h is there for you around the clock – 365 days a year. Experience shows that your Mercedes model is extremely unlikely to suffer a technical problem or breakdown. And even if the unthinkable happens, you can always count on Mercedes-Benz Service24h, wherever you are in Europe. Just call our Service Hotline on 00800 1 777 7777² at any time. One of our specialists will take your call and arrange professional assistance for you immediately. By the time you put down the phone, our Service24h team will be getting ready to make their way to you. It will often be possible to sort out the problem at the scene. If this is not the case, however, we will of course arrange for your car to be taken to the nearest Mercedes-Benz workshop.

Mercedes-Benz Bank

If you have already chosen your dream car and want to remain financially flexible, the Mercedes-Benz Bank should be your next port of call. We are your one-stop shop for leasing, financing, insurance and service packages. By way of example, our “Private Leasing plus” scheme is a complete package comprising leasing, insurance and a purchase option, while our “Plus3” finance package combines low rates with high flexibility. That’s because, at the end of the contract, you decide yourself whether to keep your car, sell it or return it to us for a guaranteed price. We also offer an attractive range of investment products, including instant-access savings accounts, fixed-interest products and investment funds. For further information, please call us on 01803/32 22 65³ or visit us at: www.mercedes-benz-bank.de

² Freephone number, mobile-phone rates may vary

³ 9 ct/min from Deutsche Telekom landlines, mobile-phone rates may vary

Time for another enriching experience

A Mercedes-Benz is most at home on the road. This is the only way to experience the effortlessly superior driving feel that lends every model its inimitable class. Feel the power of the engine as it propels the car forwards. Marvel at the precise steering, designed to really put you in the mood for driving. And experience what true comfort really feels like. The unique feeling of driving a Mercedes cannot be put into words, however. Which is why we'd like to invite you to take a test drive. Your Mercedes-Benz dealer will be happy to make all the necessary arrangements for you. Simply visit www.mercedes-benz.com to locate the nearest Mercedes-Benz dealer in your country or region. We look forward to seeing you.

The website also offers an interactive tour, enabling you to take a closer look at your desired model. This simulation is the ideal way to acquaint yourself with your dream car. You can view key functions in detail, gain an insight into the car's inner workings or look at the benefits of each model. For further details, visit www.mercedes-benz.de/owners-manual

Now your mobile phone acts as a gateway to the whole Mercedes-Benz world. In addition to an overview of all passenger car models, there are insights into the entire brand world, not to mention a wealth of entertainment offers and direct links to a range of services at www.mercedes.mobi

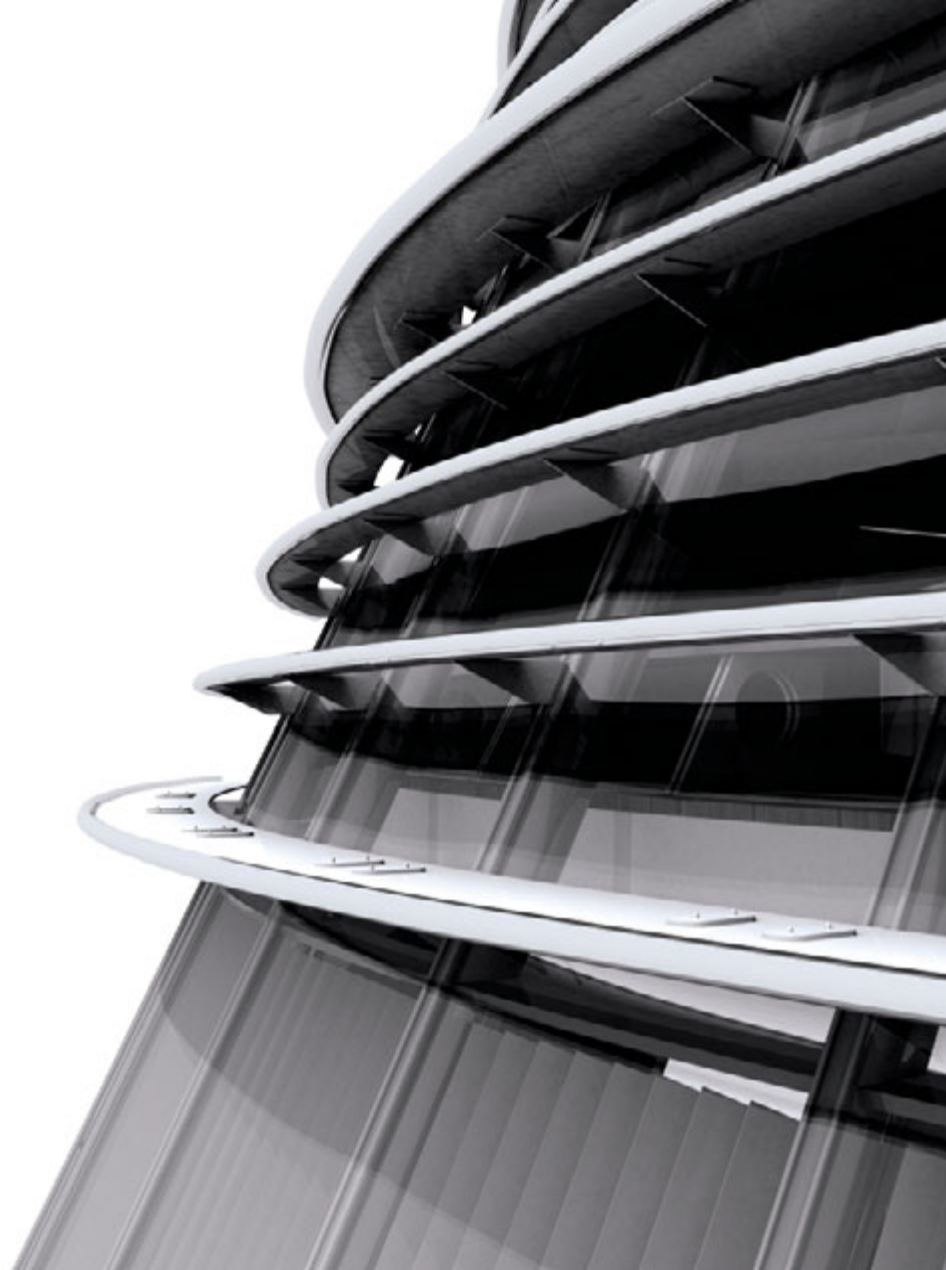

Take-back of end-of-life vehicles. Coming full circle

At the end of its long life, you can return your GL-Class to us for environment-friendly disposal in accordance with the EC End-Of-Life Vehicle Directive¹. But that day lies a long way off.

¹ Applies in accordance with national regulations to vehicles up to 3.5 tonnes gross weight. Mercedes-Benz passenger cars have met the statutory regulations governing the suitability of their design for reuse and recycling for a number of years now. A network of vehicle take-back depots and dismantlers has been established which will process your vehicle in an environment-friendly manner. The ways in which both vehicles and parts can be recovered are subject to ongoing development and improvement. Consequently, the GL-Class will be able to comply with any future increases in the recycling quota within the stipulated time limits. For further information, call 00800 1 777 7777.

Please note: changes may have been made to the product since this brochure went to press (15.08.2008). The manufacturer reserves the right to make changes to the design, form, colour and specification during the delivery period, provided these changes, while taking into account the interests of the vendor, can be deemed reasonable with respect to the purchaser. Where the vendor or the manufacturer uses symbols or numbers to describe an order or the subject of an order, no rights may be derived solely from these. The illustrations may show accessories and items of optional equipment which are not part of standard specification. Colours may differ slightly from those shown in the brochure, owing to the limitations of the printing process. This brochure has been compiled by Daimler AG of Germany and is distributed internationally. It provides a general indication of the range of models, features, optional extras and/or colours available in various countries. Some of the models, features, optional extras and/or colours shown may not be available in your country or may only be available in a different specification. Additionally some models, features, optional extras and/or colours may only be available in combination with others. For current and more specific information in relation to the range of models, features, optional extras and/or colours available in your country, and their pricing, you should contact your nearest authorised Mercedes-Benz Passenger Car Dealer.