



This Brochure is prepared by Daimler AG and it predominantly reflects the capabilities and performance of vehicles sold in Europe. Some characteristics, capabilities, performance features and optional extras (e.g. towing systems) may not be available or may not apply in Australia or under Australian conditions. The information in this Brochure is therefore indicative, illustrative and provided only for guidance and should not be relied on. To obtain current and accurate information on a vehicle and any options applicable to Australia, contact your local authorised Mercedes-Benz dealer.

Mercedes-Benz



Mercedes-Benz

The SLK-Class

Direct from the Mercedes-Benz Dream Factory

Contents

The SLK	4	My SLK	44
Agility	6	Equipment	46
Exterior design	6	Sports package	46
Driving dynamics	14	Standard equipment	48
Vario-roof	16	Optional extras	50
TrueBlueSolutions	18	Light-alloy wheels	52
Petrol engines	20	Audio and communication systems	54
Transmissions	24		
		Genuine accessories	58
Safety	26	designo	60
Active safety	26		
Passive safety	28		
		Colours and materials	62
Comfort	30	Paint finishes	62
Interior design	30	Upholstery and trim elements	64
		Possible combinations	66
COMAND APS	36		
		Technical data	68
AMG	38	Dimensions	69
SLK 55 AMG	38	Service and test drive	70
AMG <i>PERFORMANCE STUDIO</i>	40		
AMG optional extras	42		

Start measuring time a new way

Ever since Einstein we have known that neither time nor space are absolute dimensions. Time can drag by ever so slowly, for example when you are waiting for something much longed-for, whereas in moments of happiness it feels as if it literally flies by. Seen from this perspective, the SLK is something of a time machine. A roadster and at the same time a full-blooded coupé, created in order to experience each moment as intensely as possible. Come along for a little time travel and become part of this fascinating motor car's success story.

The SLK





From 0 to absolute fascination in 0.1 seconds flat

Exterior design

First impressions count, and are furthermore seldom reconsidered. One glance is all it takes for the brain to make a split-second, instinctive decision. Now, if it's fascination at first sight the moment you see the SLK, this could be due to its classic roadster proportions with short overhangs and a dynamically styled front end, to-

gether with the sporty looks of the light-alloy wheels. Whatever the reason, one thing is certain: a lot has been said and written about designing cars. And a lot of verbose expositions have been made about this or that formal idiom, or these or those flowing lines. But in all honesty – one look at the SLK says it all.









As time goes by, fascination turns into a lasting captivation

The exterior design

Its very design makes you want to set it in motion. With its beguiling looks, the SLK forms a thoroughly impressive package from nose to tail. It goes without saying, of course, that the rear end of the SLK is every bit as eye-catching as its striking front, courtesy of distinctive tailpipes, the bumper with a hint of a diffuser at the bottom, as well as the dark-tinted tail lights. Consequently, the instant you set eyes on the SLK, you will feel an urge ... to get behind the wheel.











Discover the joy of the perpetual perfect moment

Agility

You are enjoying the exhilarating acceleration and the incomparable sensation of open-top motoring: there are moments when absolutely everything seems perfect. Those are precisely the occasions for which we built the SLK. Then, time somehow seems to go faster, so that even driving great distances becomes an enthralling experience because of its intensity. Effortlessly superior agility, dynamism you can feel, plus remarkably precise handling with the optional Direct-Steer system all allow you to experience sportiness in an entirely new way aboard this timelessly beautiful roadster. Every single day, should you wish.

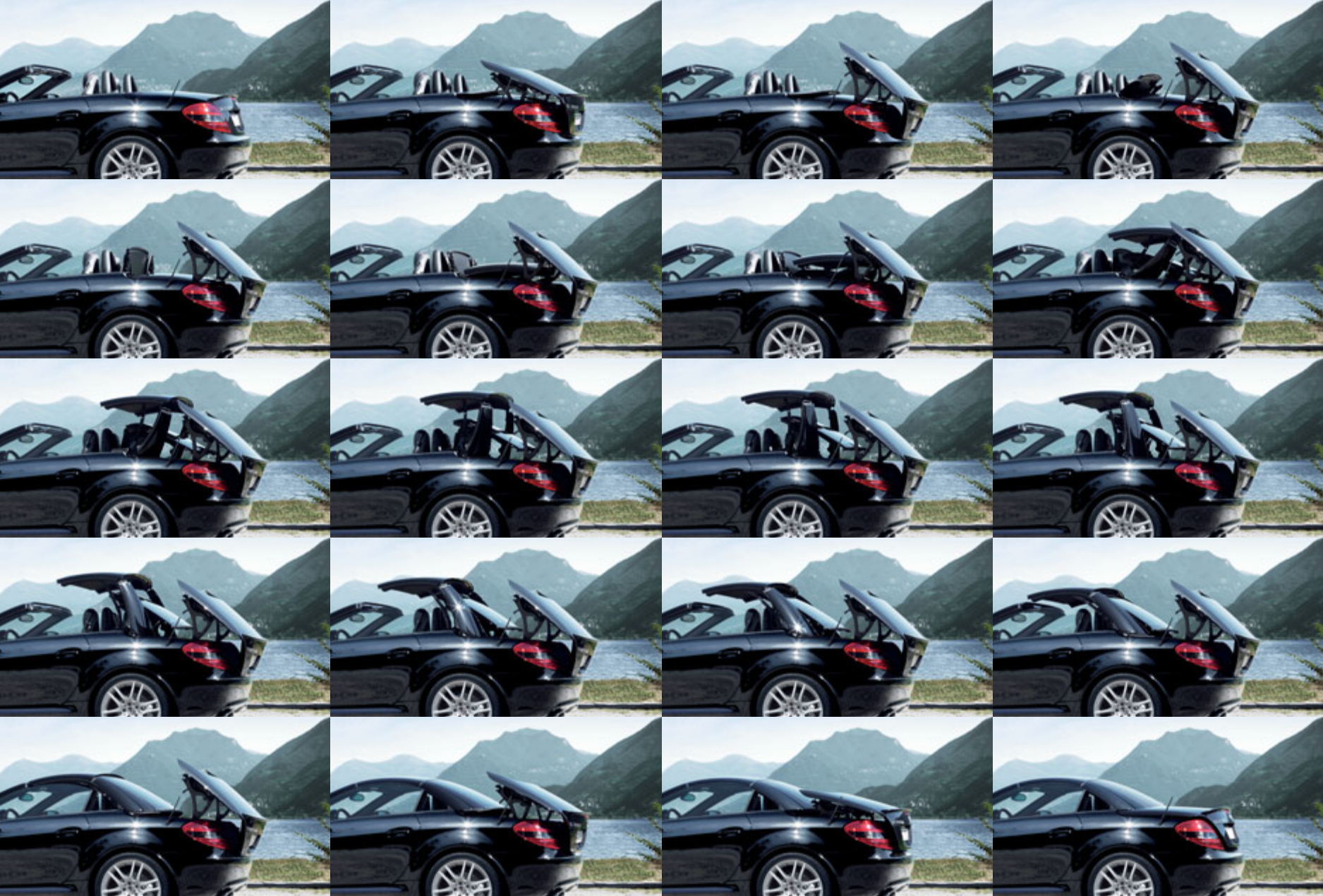

Infinite headroom, instantly. This really is unique in this segment. Pressing a button is all it takes for the vario-roof to disappear into the boot in 22 seconds. In the closed position, you will benefit from the pleasant noise insulation it provides, and the reassuring feeling of having a solid roof over your head. With the roof lowered, there is 208 litres of luggage space available. With the roof raised, it's even more: 300 litres.

In order to prevent irritating airflow turbulence in the neck region from diluting the roadster sensation when driving with the top down, you have a choice of two optional draught-stop systems.

And if you are looking to drive with the roof open even when the warm summer days are a distant memory, you will be thrilled with the AIRSCARF neck-level heating system that is exclusive to Mercedes-Benz. Here, air flowing out of the head restraint provides warmth in the head and neck region, enabling you to enjoy the roadster season all year long, if you so desire.



TrueBlueSolutions

Climate change is one of the major challenges of the 21st century. The rising consumption of natural resources is having an increasing impact on our planet. As the inventor of the motor car, Mercedes-Benz has a special responsibility to implement innovative technologies in order to develop solutions that help preserve the environment and ensure that raw materials are used as efficiently as possible – without compromising on comfort, safety and driving enjoyment. We call them TrueBlueSolutions.

Our goal is emission-free mobility. To achieve this goal, we have developed a number of concepts, one of which is **BlueEFFICIENCY**. This custom-designed package of efficiency measures can reduce fuel consumption by up to 12 %: various aerodynamic and energy-management measures are implemented individually for each model to maximise savings in each case. These include tyres with low rolling resistance, lightweight materials, changes to the body aerodynamics and the automatic ECO start/stop function. As for

diesel engines, Mercedes-Benz has brought to market its **BlueTEC** technology based on common-rail direct injection (CDI). This technology is the embodiment of the world's cleanest diesel as it can reduce nitrogen oxides by up to 80 %. Great things are also expected of **BlueHYBRID** technology - a combination of a highly efficient internal combustion engine and an electric motor. Vehicles equipped with this drive system raise the bar once again in terms of economy and cleanliness, as will be shown by the S-Class from 2009 onwards. Mercedes-Benz calls the equivalent technology for diesel vehicles **BlueTEC HYBRID**. A prototype



BlueTEC. The world's cleanest diesel technology in a modern-day vehicle. The E-Class is also available with BlueTEC technology

version of this system can be seen in the Vision GLK 300 BlueTEC HYBRID¹, which is currently the world's cleanest and most economical SUV. It returns a combined consumption figure of just 5.9 l/100 km. And with the F700 research vehicle, we have succeeded in combining the advantages of a petrol engine with those of a diesel powerplant. The **DIESOTTO** drive at the heart of the F700 may have petrol in the tank; however, it operates like an economical diesel model in many driving situations. Mercedes-Benz also sees great potential in the development of the fuel cell. This highly promising drive system requires no



BlueEFFICIENCY. Numerous models, various measures, one goal: maximum efficiency

mineral fuel whatsoever and operates with zero emissions. The first of these vehicles to be built under series-production conditions – the B-Class F-CELL – is due in 2010.

However, our extensive TrueBlueSolutions concept does not just include new drive technologies. Under the banner **Design for Environment**, we look at the vehicle's entire lifecycle – from planning to recycling. The same applies to the building and running of new plants. We save energy, avoid pollutants and increase the use of renewable raw materials. Incidentally, Mercedes-Benz is the



BlueHYBRID. Looking forward to one of the world's most economical luxury saloons. The S-Class from 2009

world's only car brand to have received the independently awarded TÜV² environmental certificate. TrueBlueSolutions also involves the active participation of the Group and its employees in environmental protection measures both inside and outside the company's plants. And it incorporates a commitment to developing second-generation alternative fuels (BTL/Biomass-to-Liquid fuels), such as SunDiesel[®], which are not at odds with food production. Another aspect of TrueBlueSolutions is the research discipline of bionics, which looks at structures and designs in the natural world in order to optimise the



BlueTEC HYBRID. The Vision GLK 300 BlueTEC HYBRID¹ is the most efficient combination of BlueTEC diesel and hybrid modules

weight and aerodynamics of body constructions, for example. Last but not least, you can also do your bit for TrueBlueSolutions by adapting your driving style.

For further information on our extensive package of measures, go to www.mercedes-benz.com/truebluesolutions

¹ Provisional figures: combined fuel consumption: 5.9l/100 km; overall CO₂ emissions: 157 g/km

The figures are not based on an individual vehicle and do not constitute part of the product offer; they are provided solely for purposes of comparison between different vehicle models

² TÜV SÜD Management Service GmbH, Munich



F-CELL. Emission-free mobility with the drive system of the future: the B-Class F-CELL goes into production in 2010

High time for a most powerful argument

The SLK 350 sports engine

More than enough power for getting away from it all. The SLK offers you the widest choice of engines in its class. They all have one thing in common: they turn every drive in your SLK into a most moving experience, and, thanks to the vehicle's generously-sized 70-litre fuel tank and the resulting range, you can revel in it at great length.

Take the lively SLK 350 sports engine, for instance. This six-cylinder unit just loves to accel-

erate the car, with a formidable 224 kW (305 hp) at its disposal, and truly makes its mark with a high-revving design that permits engine speeds of up to 7200 rpm. What's more, it delivers a thrilling sound that truly gets under your skin over the entire rev band, as well as power galore for tasting pure driving bliss. One final thing worth mentioning is that, despite the tremendous power output, our engineers have actually succeeded in cutting both the engine's fuel consumption and its pollutant emissions.

SLK 350 sports engine

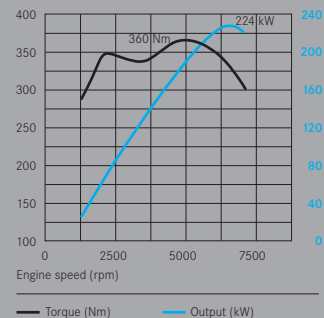





A temperament to suit all tastes

The SLK 200 KOMPRESSOR and the SLK 280

Delivering an output of 135 kW (184 hp), the SLK 200 KOMPRESSOR propels the SLK along in agile, dynamic fashion, while delighting with its understated yet resonant sound. The SLK 280 promises an even sportier drive, mustering up as it does 170 kW (231 hp) from its displacement of 2996 cc. And thanks to its uniform power delivery and impressive refinement, the SLK 280 succeeds in fusing motoring comfort with motoring pleasure.

To continue as the leaders of tomorrow, it is vital to think in terms of sustainability today. That's why we have significantly reduced the CO₂ emissions and fuel consumption of the engines detailed here, in spite of their impressive output figures. Please refer to page 68 for more information on fuel consumption and CO₂ emissions.

SLK 200 KOMPRESSOR

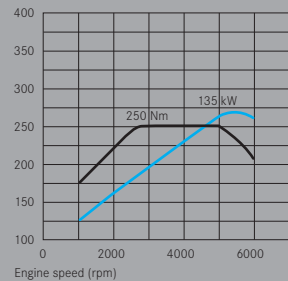

SLK 280

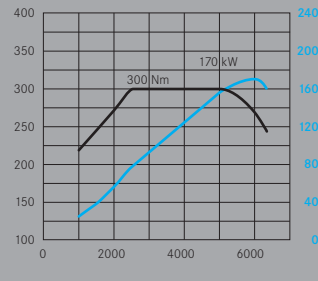

— Torque (Nm) — Output (kW)



As precise as a Swiss watch – and saves fuel too

The transmissions

The SLK stands for responsiveness and agility of the highest degree. And if you move fast, you must be able to shift fast, too. That's why the power of the various engines is transferred by transmissions which are precisely attuned to the temperament of each model. You can choose between the standard 6-speed manual transmission and an optional 5-speed automatic transmission for the SLK 200 KOMPRESSOR. For those who prefer one of the 6-cylinder engines, 7G-TRONIC, the 7-speed automatic transmission, is available as an option. In the SLK 55 AMG, this transmission is standard.

The optional 7G-TRONIC Sport with steering-wheel gearshift paddles ensures even swifter gearshifts. These steering-wheel gearshift paddles can be ordered as optional equipment for all automatic transmissions, and are likewise included as standard on the SLK 55 AMG.

With its seven speeds, the 7G-TRONIC automatic transmission adapts marvellously to every driving situation. The seven ratios ensure that the jumps in rev speed from one gear to the next are small, resulting in smoother gearshifts and a lower average rev speed level. In addition, it offers the possibility of multiple downshifts for extra-fast acceleration at any time.



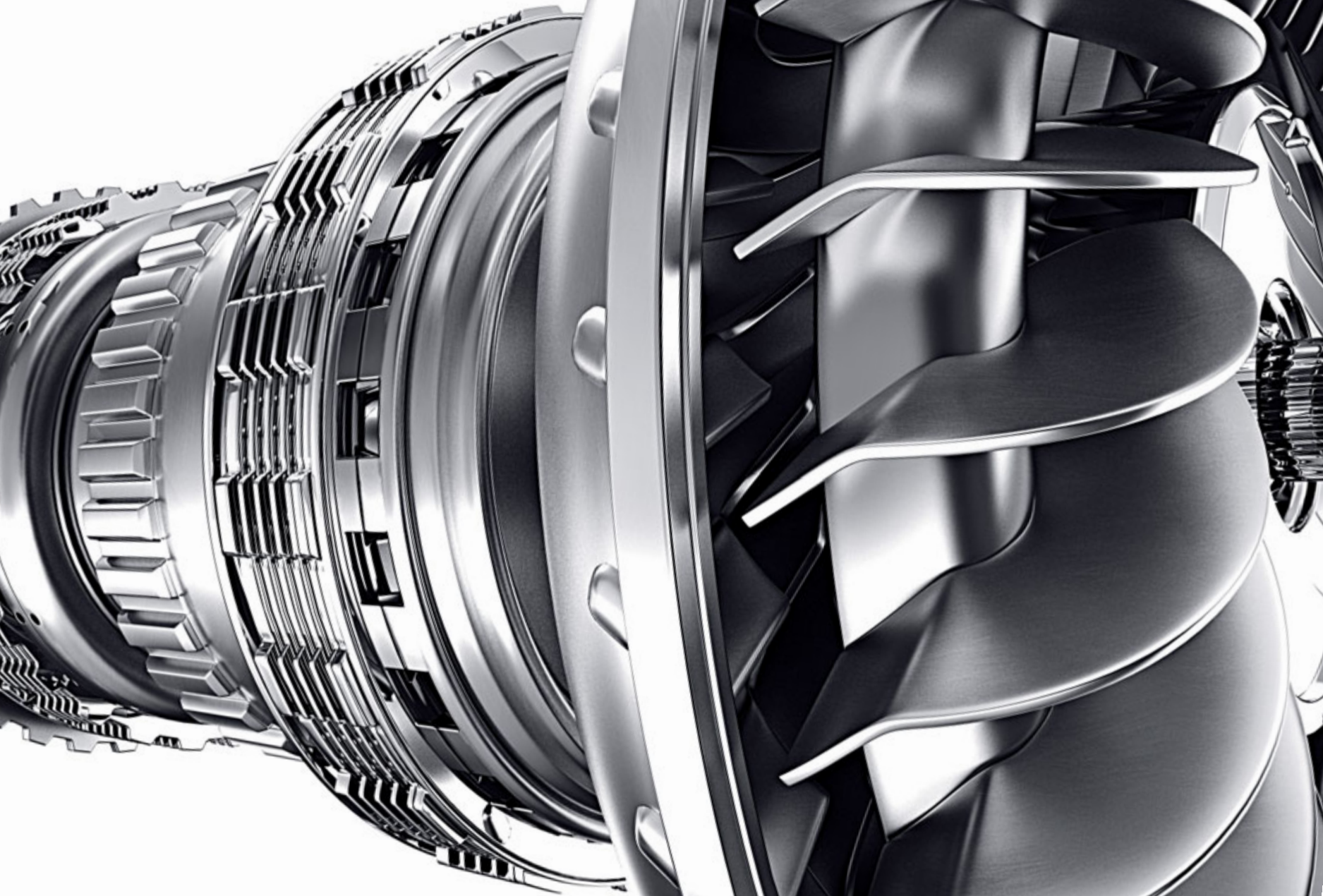



SLK280



S 0T 9481



When your safety is at stake, the SLK takes action in an instant

Active safety

To prevent accidents from happening in the first place, a high level of active safety is built-in for undiluted driving pleasure. Your SLK is, of course, equipped with ESP® and BAS as standard. If the vehicle is at risk of entering a skid, ESP® helps to defuse the situation through targeted interventions in the braking and engine management

systems. Meanwhile, the electronic Brake Assist system detects emergency braking from the speed with which you press the brake pedal, whereupon it instantly builds up maximum braking power. Further information about the Mercedes-Benz safety concept is available online at: www.mercedes-benz.com/airbag-brochure

Years of research shows its worth in a split second

Passive safety

What might be awaiting you around the next bend? There may indeed be questions for which no safety system yet has the answer, but in practically all other situations you can rely on the SLK's intelligent safety concept. Should the worst come to the worst, you will be protected by belt tensioners as well as adaptive driver's and passenger's airbags. In addition, the SLK is equipped with head/thorax sidebags too. These are located in the outside edges of the seat backrests, and together with the roll-over sensor,

they afford the best possible occupant protection in the event of a lateral collision or of the vehicle overturning. All these systems have been integrated in an extremely torsionally-rigid passenger safety cell which, in combination with the roll-over bars built into the vehicle body, ensures you always keep on the safe side in spite of all the vehicle's openness. Added to this is the fact that the robust steel construction of the vario-roof when closed offers even greater safety.



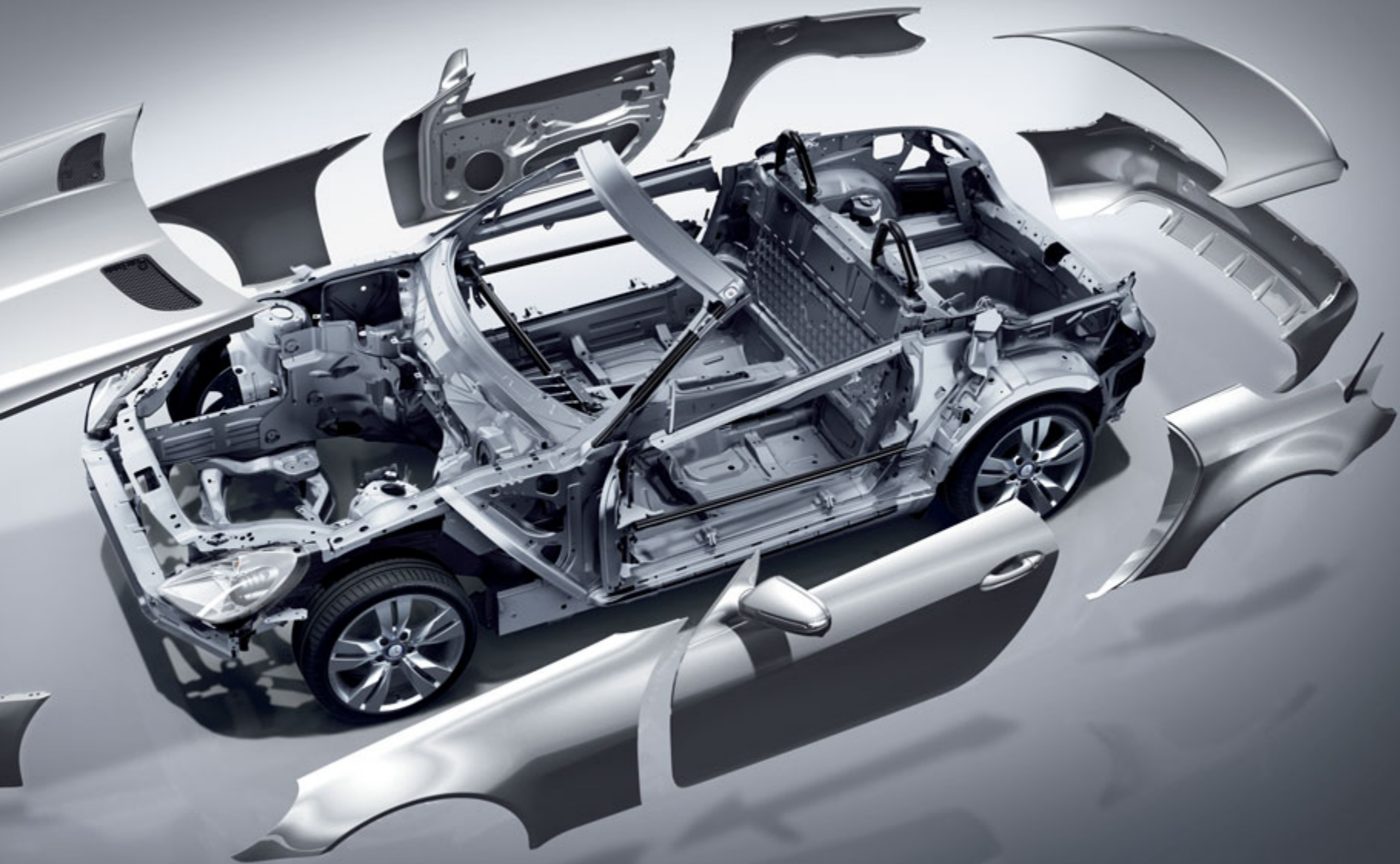

Ergonomics can either be explained at length, or felt at once

Interior design

If you want to have fun, you have no time to waste. That's why it is good if all the controls and displays are not only crafted with the highest degree of workmanship, but are also placed just



The 3-spoke sports steering wheel features practical multifunction buttons as standard

where you would intuitively expect them to be. Because that is the only way to have the reassuring feeling of being in direct control of the vehicle: a control so powerful and intense that it almost makes you feel at one with the vehicle's technology. The sports steering wheel with standard-fit multifunction buttons feels good in your hands, while the interior can be given a particularly refined air by opting for the exclusive wood trims in a choice of light burr walnut and black ash. Positioned directly in your field of vision to keep you constantly informed of all key data is the instrument cluster, which stands out for its understated good looks with red needles, elegant dial bezels in a 3D look, plus tubes with chrome surrounds.

USE APPROPRIATE SPEED
FOR YOUR AREA
© 2011
VOLVO CAR CORP.



FM 4

↑
SWR3
↓

+23.0 °C



Open for spontaneous decisions

Interior design

The interior of the SLK is the perfect place for enjoying yourself. Awaiting you here is a stylish symbiosis of out-and-out sportiness on the one hand and, on the other, a degree of space and comfort which is otherwise unheard of in this segment. The result is a clear enhancement of motoring pleasure. The optional leather appointments allow you to give your SLK an even more exclusive look: you can choose from leather in black, alpaca grey, orient beige or gullwing red.

And anyone looking for an even greater air of refinement can opt for the luxurious nappa leather appointments: here, the seats are upholstered in finest nappa leather in either black or natural beige, and even the centre armrest is trimmed in soft black nappa, complete with elegant topstitching. Whatever you decide on, you can be sure of exceptional build and material quality. The SLK is, after all, one thing above all else: a Mercedes.





Mercedes-Benz



Sport has seldom been so relaxing

Driving comfort

This is just how comfortable sporty motoring can be. You will start to appreciate the excellent lateral support of the dynamically contoured seats with their magnesium frame on your very first outing. Then there is the spontaneous, agile handling of the optional Direct-Steer system with variable servo assistance, which is unrivalled in this segment and positively invites you to power through bends in the road. Thanks to the outstanding suspension tuning, even longer journeys are nothing less than an absolute delight. You also have the option of AIRSCARF neck-level heating, the only system of its kind in the world: by delivering pleasantly warm air from the head restraints it allows you to extend the cabriolet season at the touch of a button. And to maintain a refreshing climate when the roof is up too,

there is either the air conditioning system that comes as standard in the SLK 280, SLK 350 and SLK 55 AMG, or the optional luxury automatic climate control THERMOTRONIC featuring automatic regulation of the air distribution, plus solar and air quality sensors.



The innovative AIRSCARF neck-level heating can keep your head and neck snug and warm as an option



RADIO

DISC

NAVI

TEL



SYS



ON

11:47

TA

Navi Audio Tel Video System

1. SWR1 BW 101.3 MHz

3 SWR3

2. SWR2 BW 4. 102.3 MHz

Radio Speicher FM Klang

1

2

3

QW

ABC

DEF

4

5

6

GHI

JKL

MNO

7

8

9

PQRS

TUV

WXYZ



If you wish, your SLK can listen to your every word

Ease of operation

At last! A car that understands you. This is because you have the option of the sophisticated COMAND APS multimedia system. The system's intuitive user guidance makes it more user-friendly than ever, despite its vast array of functions. The COMAND APS features a fast hard-disc navigation system including a 3D display, a MUSIC REGISTER for storing audio files, plus a high-resolution 6.5-inch colour display, to name but a few of the highlights. The entire system can be operated from an ergonomically positioned control pad. What's more, the SLK can also be ordered with the voice-operated control system LINGUATRONIC for operating the audio, telephone and navigation systems. The system is already contained within the COMAND APS and can also be added to the optional Audio 50 APS, if you wish.



The multifunction buttons give you the option of controlling many of the COMAND APS system's functions directly from the steering wheel

AMG. Three letters – one clear statement

The SLK 55 AMG

You can see it immediately just from the outside: this is as SLK as it gets. Because the SLK 55 AMG interprets the sporty, elegant look of the classic roadster more assertively and uncompromisingly than ever. And it lives up to this exterior promise in every way by delivering true sports car performance. Under the bonnet, an AMG V8 engine with a displacement of 5.5 litres generates a



brehtaking 265 kW (360 hp) and a maximum torque of 510 Nm. The SLK 55 AMG reaches the 100 km/h mark in 4.9 seconds. More than sufficient to press you with pleasant firmness back into the exclusive AMG nappa leather sports seats. The SLK 55 AMG is equipped as standard with the innovative AMG SPEEDSHIFT 7G-TRONIC, which permits extra-swift gear-shifting. The transmission can also be controlled by means of the steering-wheel gearshift paddles on the AMG sports steering wheel. Further highlights of the extensive high-performance specification of the SLK 55 AMG are the AMG sports suspension and the 18-inch AMG multi-spoke light-alloy wheels in a high-sheen, titanium grey-painted finish that are exclusive to this model.







If the only sports that count for you are high-performance sports

The AMG PERFORMANCE STUDIO

For even more dynamic driving, there are exclusive optional extras available for the SLK 55 AMG from the AMG PERFORMANCE STUDIO. Here, for instance, you can opt for the multi-piece 18-inch AMG light-alloy wheels in twin-spoke design, an AMG performance suspension, as well as AMG carbon-fibre trim elements and the AMG

performance steering wheel, with its flattened lower section and smaller rim diameter. For ultimate motoring pleasure there is the highly attractive AMG performance package, which comprises an AMG high-performance composite brake system in addition to the features mentioned above.



Where would an athlete be without the right outfit?

The optional AMG bodystyling and 18-inch AMG light-alloy wheels

If you don't want to go for the SLK 55 AMG right away, you still have the option of underlining the SLK's sportiness to most striking effect with the AMG bodystyling package. This package, created by Mercedes-AMG and consisting of dynamic-looking AMG aprons at the front and rear as well as muscular side skirts, lends the SLK a particularly athletic look.

In addition, the AMG spoiler lip neatly rounds off the exterior design, at the same time enhancing downforce and thus handling stability. Optionally, all SLK models can be fitted with high-shine 18-inch twin-spoke AMG light-alloy wheels, shod with 225/40 R 18 tyres at the front and 245/35 R 18 tyres at the rear.









My SLK

The most beautiful combination of sports and aesthetics

The SLK with the sports package

Sportiness lies in the nature of the SLK. And the optional SLK sports package allows you to elicit this temperament to stunning effect. The extensive package includes headlamp linings in a matt grey finish, as well as 18-inch 6-twin-spoke light-alloy wheels that lend yet greater emphasis to the car's dynamic appearance.



The striking perforated brake discs at the front provide extra reserves of stopping power, while the AMG spoiler lip on the tail generates even greater downforce at the rear axle. A sports suspension is likewise fitted as standard, and gearshift paddles on the steering wheel are also included on models with the optional automatic transmission.



Yet the sports package can be admired equally as well from the interior. Here you will find a black roof liner, red seat belts (optionally available in black), plus red topstitching on the seats, armrest, steering wheel and gearshift lever. Attractive carbon-look trim elements and floor mats with red edging round off the interior concept of the sports package in style.







The roll-over bars offer added protection if the worst comes to the worst



Cruise control makes for more relaxed motoring and can also reduce fuel consumption



The 3-spoke sports steering wheel with multifunction buttons as standard



The dark-tinted tail lights add to the sporty looks



Front fog lamps ensure clear visibility even in the most dreary weather



The shorter rod aerial is suitable for automatic car washes

Standard equipment (selection)

16-inch, 7-spoke light-alloy wheels ⁴
3-spoke sports steering wheel with multifunction buttons
6-speed manual transmission ¹
Adaptive front airbags and head/thorax bags (enlarged sidebag providing additional head protection) for driver and passenger
Air conditioning system including dust filter and activated charcoal filter ³
Anti-lock braking system (ABS)
ASSYST PLUS service interval indicator with service computer
Automatic heating and ventilation system with dust filter and air recirculation button with convenience feature (automatic window closing)
Automatic seat occupancy recognition/child seat recognition in passenger seat
Aux-in connection in glove compartment (omitted if optional media interface fitted) ²
Belt tensioners with belt force limiters
Cruise control with SPEEDTRONIC variable speed limiter
Dark-tinted tail lights
Designer key (ignition key with chrome highlight)
Driver and passenger seats height-adjustable
Electrohydraulic vario-roof, vehicle-coloured, with heated rear windscreen
Electronic immobiliser with locking system and radio remote control
Electronic Stability Program ESP®
Fog lamps front and rear

Folding armrest with compartment
Indicator lamps in exterior mirrors
Interior lighting switch-on after accident
Power socket (12 V) in passenger footwell
Power steering and safety steering column
Remote boot-lid release
Roll-over bars for driver and passenger
Short rod aerial, suitable for automatic car washes
Sports seats with magnesium backrest (folding) and integral head restraint
Steering column manually adjustable for height and reach
Stowage box on rear bulkhead, between seats
Stowage net in passenger footwell
Tinted windows all round
TIREFIT tyre sealant with electric pump
Trapezoidal-section tailpipes

¹ 7G-TRONIC automatic transmission standard for SLK 55 AMG² Only in conjunction with Audio 20 CD, Audio 50 APS or COMAND APS³ Available for SLK 200 KOMPRESSOR as an option⁴ 16-inch 5-spoke wheels for SLK 280, 17-inch 5-twin-spoke wheels for SLK 350, 18-inch multi-spoke wheels for SLK 55 AMG



Thanks to the innovative AIRSCARF neck-level heating, you can enjoy open-top motoring without having to endure chilly temperatures in the head and neck region



The 3-spoke sports steering wheel is optionally available with shift paddles for changing through the gears manually



The luxury automatic climate control THERMOTRONIC with automatic regulation of the air distribution



The electric seat adjustment control reproduces the shape of the seat, making it particularly user-friendly

Optional extras (selection)	SLK 200 K	SLK 280	SLK 350	SLK 55 AMG
5-speed automatic transmission	●	–	–	–
7G-TRONIC 7-speed automatic transmission	–	●	●	○ ²
Adjustable (4-way) lumbar support for driver and passenger	●	●	●	–
AIRSCARF neck-level heating with fabric draught-stop	●	●	●	●
AMG bodystyling	●	●	●	○
Anti-theft alarm system (ATA) with tow-away protection	●	●	●	●
Audio 20 CD (with colour display, MP3 capability and Bluetooth hands-free system)	●	●	●	●
Audio 50 APS (plus DVD arrow-based navigation and Junction View)	●	●	●	●
Battery with increased capacity	●	○	○	○
Bi-xenon headlamps with headlamp cleaning system, dynamic range adjustment and cornering light function	●	●	●	●
COMAND APS multimedia system for audio, navigation and telephone, incl. high-resolution 6.5-inch display, hard-disc navigation, MUSIC REGISTER and voice-operated control system LINGUATRONIC	●	●	●	●
Direct-Steer system with variable servo assistance	● ³	●	●	○
Harman Kardon® Logic 7® surround sound system with Dolby 5.1 / DTS	●	●	●	●
Heated windscreen washer system	●	●	●	●
Interior lighting package	●	●	○	○
Lowered sports suspension	● ³	●	●	–
Media interface, e.g. for MP3 player, iPod and USB stick	●	●	●	●
Memory package for driver's seat, steering column and mirrors	●	●	●	●
PARKTRONIC	●	●	●	●
Sports package	●	●	●	–
Steering-wheel gearshift paddles ¹	●	●	●	○ ²
THERMOTRONIC luxury automatic climate control	●	●	●	●
Tyre pressure loss warning system	●	●	●	●

● Optional extra ○ Standard equipment – Not available

¹ Only in conjunction with automatic transmission

² AMG SPEEDSHIFT 7G-TRONIC with steering-wheel gearshift paddles standard on SLK 55 AMG

³ Only in conjunction with mixed-size tyres

Make your mark before you even touch the ignition key

The light-alloy wheels

Light-alloy wheels are the calling card of any sporty car. Here you will find a wealth of suggestions for how to add a most personal touch to your SLK.



16-inch 7-spoke light-alloy wheel
(standard for SLK 200 KOMPRESSOR)



16-inch 5-spoke light-alloy wheel
(standard for SLK 280, optional for SLK 200 KOMPRESSOR)



17-inch 5-twin-spoke light-alloy wheel (standard for SLK 350,
optional for SLK 200 KOMPRESSOR and SLK 280)



17-inch 5-twin-spoke light-alloy wheel
(only in conjunction with sports suspension)



17-inch "Kikuchi" incenio designer wheel



18-inch AMG multi-spoke light-alloy wheel in high-sheen,
titanium grey-painted finish (standard for SLK 55 AMG)



17-inch 10-spoke light-alloy wheel in "chrome shadow"
high-gloss painted finish



18-inch "Korsunia" incenio designer wheel



18-inch AMG twin-spoke light-alloy wheel, multi-piece
(optional for SLK 55 AMG)



18-inch 6-twin-spoke light-alloy wheel
(only in conjunction with sports package)



18-inch AMG twin-spoke light-alloy wheel, high-sheen finish

Crystal clear and as impressive as the SLK itself

The Harman Kardon® Logic 7® surround sound system

If you would like to experience Dolby 5.1 digital sound in a class of its own, there is the option of the Harman Kardon® Logic 7® surround sound system with an output of 500 watts. This system has been specially developed for the SLK and delivers pure listening pleasure for both driver

and passenger through its eleven speakers. Regardless of whether the roof is up or down, or the recording is in stereo or 5.1: this is a high-end hi-fi system that is music to everyone's ears.

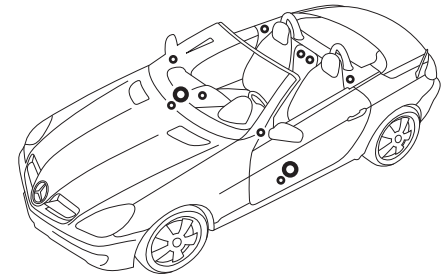

The clever arrangement of the speakers generates a sound field optimised specifically for the SLK, so you are able to enjoy a pristine sound at all times, even when driving with the roof down





AIRBAG

11:04 FM 92.2 MHz
DIE NEUE SWR4 5
SWR3
DKL TUR 89.3 MHz
Radio Speicher Klang



HILFE ANFORDERN

56

Welcome to today's communication society. There are a number of audio and communication systems to choose from for your SLK. A common feature of all radio systems is the standard-fit Bluetooth hands-free system. The range starts with the optional Audio 20 CD featuring a 5-inch colour screen, built-in CD player with MP3 capability (can be upgraded to a built-in 6-disc CD changer) and an Aux-in connection in the glove compartment for connecting portable audio devices.

The Audio 50 APS supplements this with a DVD navigation system featuring an arrow-based display and Junction View. Anyone also opting for the built-in 6-disc DVD changer can enjoy the added luxury of the intuitive voice-operated control system LINGUATRONIC. This highly convenient means of control is included as standard with the COMAND APS, the innovative multimedia system with hard-disc navigation, including a 3D display and high-resolution 6.5-inch screen. In addition to this, COMAND APS comes with a MUSIC REGISTER, an SD memory card slot, plus a DVD video function.



The optional Audio 50 APS radio system can be upgraded to include a 6-disc DVD changer



The optional COMAND APS has a multimedia controller interface, allowing you to operate a host of functions with ease



Ready for the finishing touches

Genuine accessories from Mercedes-Benz

Nothing impresses quite like the real thing. With genuine Mercedes-Benz accessories you can make even more out of your SLK. Take, for instance, the optional three-piece draught-stop with a transparent perspex panel and the two



The perspex draught-stop reduces airflow turbulence

plastic-framed mesh sections. These practical accessories help reduce airflow turbulence in the neck area and can be attached between the roll-over bars in next to no time. You can create further highlights too by adding spoiler lips for



The attractive SLK holdall is designed to match your SLK perfectly

the front apron, for example, or the 18-inch “Korsunia” incenio designer wheels in 5-triple-spoke design (pictured left) to enhance the dynamic appearance of your SLK even more.



17-inch “Kikuchi” incenio designer wheel in 5-twin-spoke design for a most personalised look

As individual as you are

The designo appointments

Custom-design your SLK as you please. Fine woods and exquisite leather upholstery – or combined leather and Alcantara – with striking double topstitching give the interior an exclusive and highly individual flair. Matching

leather-covered trim elements and roll-over bars are available as an option. For further information, please refer to our extensive designo brochure.





The SLK paintwork puts the finishing touch to the carefully crafted Mercedes-Benz corrosion protection system, which includes zinc phosphating and electrophoretic dip priming stages for long-lasting protection. We also make very extensive use of eco-friendly water-based paints.

NON-METALLIC PAINTS

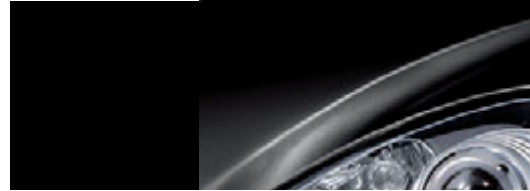

040 black



590 fire opal



650 calcite white

METALLIC PAINTS



197 obsidian black



300 periclase green



345 jasper blue

SPECIAL PAINT



359 tanzanite blue

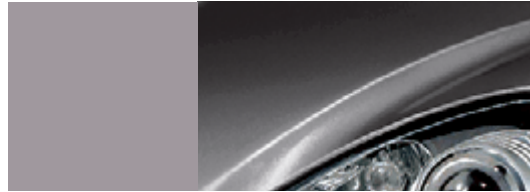

775 iridium silver



430 prehnite green



541 thulite red



792 palladium silver



723 cubanite silver

The seats of a Mercedes-Benz excel with a particularly high level of comfort, thanks to the special way in which the seat cushions are sprung and the use of separate foam elements for the centre panel of the seat cushion and the sides. The combination of the seat cushion spring set-up, which is precisely tuned to the vehicle, and the selection of the appropriate degree of cushion density results in exceptional springing and damping characteristics. To finish them, the seats are then upholstered in your own personal choice of fabric or leather.

FABRIC

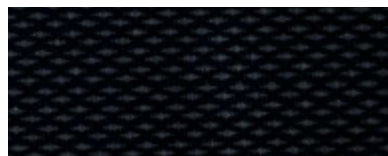
081 black¹

LEATHER

801 (851) black²808 (858) alpaca grey²815 (855) orient beige²817 (887) gullwing red²

¹ Standard specification

² Codes in brackets = standard nappa leather for SLK 55 AMG

³ For further information, please see designo brochure

⁴ Available for the sports package

NAPPA LEATHER



861 black

designo³ LEATHER, LEATHER/ALCANTARA

X11 single-tone black

TRIM ELEMENTS

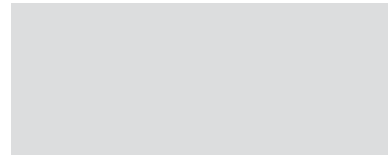
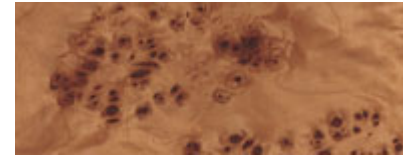
7H72 avus silver¹designo³ TRIM ELEMENTS

W61 natural poplar



874 natural beige



X83 two-tone classic red



H12 light burr walnut



X20 single-tone black



736 black ash

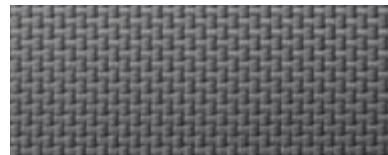

X21 single-tone alpaca grey

7K79 carbon fibre⁴

	FABRIC	LEATHER					NAPPA LEATHER		
	black		black	alpaca grey	orient beige	gullwing red		black	natural beige
NON-METALLIC PAINTS									
black	●		●	●	●	●		●	●
fire opal	●		●	●	○	●		●	○
calcite white	●		●	●	○	●		●	●
METALLIC PAINTS									
obsidian black	●		●	●	●	●		●	●
periclase green	●		●	○	△	△		●	●
jasper blue	●		●	○	△	△		●	△
tanzanite blue	●		●	●	○	△		●	●
thulite red	●		●	●	●	○		●	○
cubanite silver	●		●	●	△	●		●	○
iridium silver	●		●	○	△	●		●	●
palladium silver	●		●	●	●	●		●	△
SPECIAL PAINT									
prehnite green	●		●	●	●	△		●	○

● Recommended

○ Possible

△ Not recommended

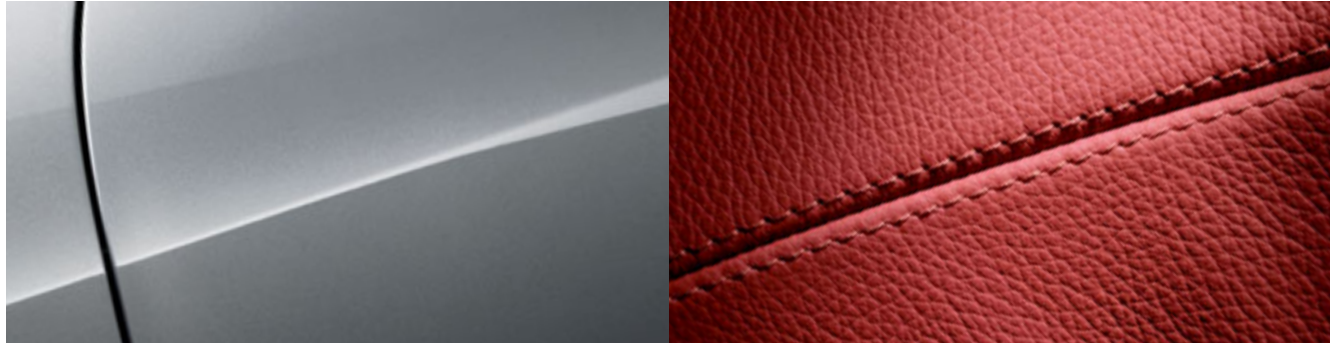

Palladium silver metallic and gullwing red leather lend a particularly sporty flair



The combination of obsidian black metallic and black leather with red topstitching¹ also produces a most athletic look

¹ Available for the sports package

	SLK 200 KOMPRESSOR	SLK 280	SLK 350 sports engine	SLK 55 AMG ⁶
No. of cylinders/arrangement	4/in-line	6/V	6/V	8/V
Total displacement (cc)	1796	2996	3498	5439
Rated output ¹ in kW (hp) at rpm	135 (184)/5500	170 (231)/6000	224 (305)/6500	265 (360)/5750
Rated torque ¹ (Nm at rpm)	250/2800–5000	300/2500–5000	360/4900	510/4000
Compression ratio	8.5	11.3	11.7	11.0
Acceleration from 0 to 100 km/h (s) (automatic transmission)	7.6 (7.9)	6.3 (6.2)	5.4 (5.4)	– (4.9)
Top speed, approx. (km/h) (automatic transmission)	236 (232)	250 ² (250) ²	250 ² (250) ²	– (250) ²
Tyre size				
front	205/55 R 16 V	205/55 R 16 W	225/45 R 17 W	225/40 R 18
rear	205/55 R 16 V	225/50 R 16 W	245/40 R 17 W	245/35 R 18
Fuel	Premium unleaded	Premium unleaded	Premium unleaded	Super Plus
Fuel consumption ³ (l/100 km)	11.0–11.2/5.7–6.0/7.7–7.9	13.6–13.8/6.7–6.9/9.3–9.5	14.2/6.9/9.5	–
Urban/extra-urban/combined (automatic transmission)	(11.5–11.8/5.9–6.2/8.0–8.2)	(13.0–13.2/6.8–7.0/9.1–9.3)	(13.1/7.0/9.2)	(17.7/8.8/12.0)
CO ₂ emissions ³ (g/km) combined (automatic transmission)	182–188 (190–196)	220–225 (216–221)	227 (219)	– (288)
Tank capacity (l)/incl. approx. reserve	70/9	70/9	70/9	70/10
Boot capacity (l) ⁴	300	300	300	300
Turning circle diameter (m)	10.51	10.51	10.51	10.51
Kerb weight ⁵ (kg) (automatic transmission)	1390 (1415)	1455 (1475)	1485 (1505)	– (1575)
Permissible gross vehicle weight (kg)	1705	1770	1800	1850

¹ Figures in accordance with Directive 80/1269/EEC in the currently applicable version

² Electronically governed

³ The figures shown were obtained in accordance with the prescribed measuring process (Directive 80/1268/EEC in the currently applicable version). The figures are not based on an individual vehicle and do not constitute part of the product offer; they are provided solely for purposes of comparison between different vehicle models

⁴ With the roof closed

⁵ Figures according to Directive 92/21/EC, version 95/48/EC (kerb weight with fuel tank 90 % full, driver, 68 kg, and luggage, 7 kg) for standard-specification vehicles. Optional extras and accessories will generally increase this figure and reduce the payload capacity accordingly

⁶ Only available with automatic transmission

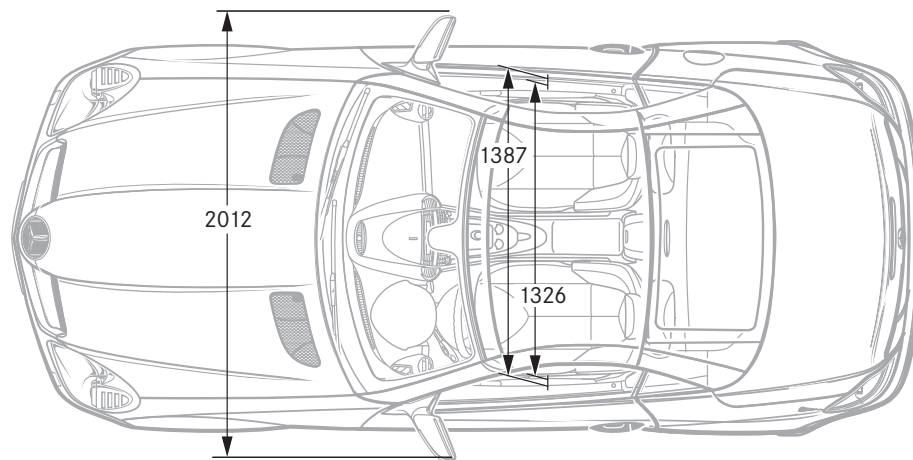
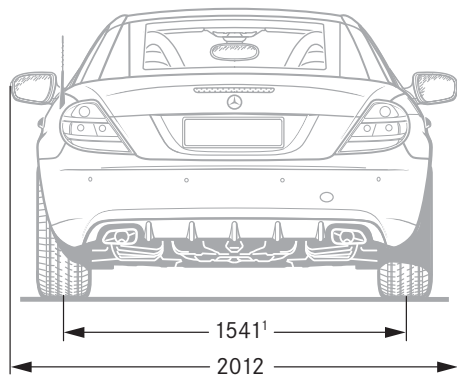
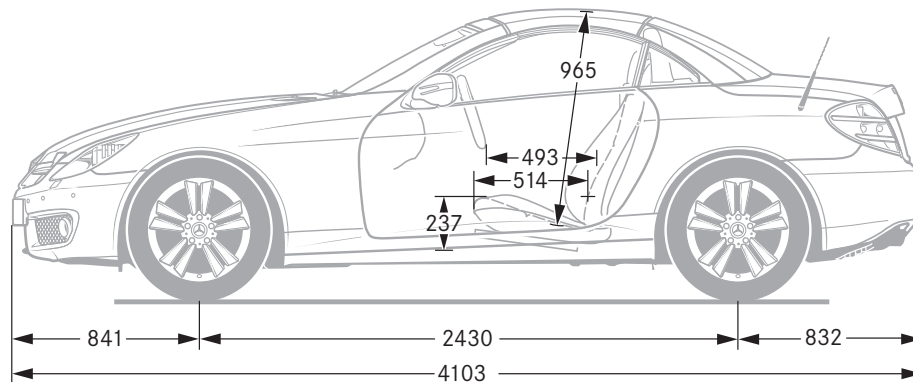
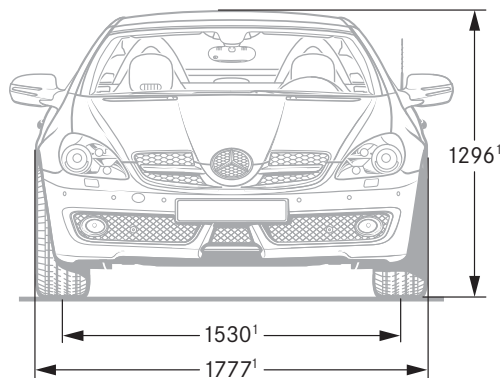

All measurements are in millimetres. The dimensions shown are mean values and apply to standard-specification, unladen vehicles

¹Dimensions apply to SLK 200 KOMPRESSOR and may deviate for other models



Anyone opting for a Mercedes buys far more than just a car

Comprehensive service offered by Mercedes-Benz

Mercedes-Benz Service24h

The feel-good factor, which kicks in when you sit behind the wheel of your new Mercedes for the first time, is further enhanced by the knowledge that Mercedes-Benz Service24h is there for you around the clock – 365 days a year. Experience shows that your Mercedes model is extremely unlikely to suffer a technical problem or breakdown. And even if the unthinkable happens, you can always count on Mercedes-Benz Service24h, wherever you are in Europe. Just call our Service Hotline on 00800 1 777 7777¹ at any time. One of our specialists will take your call and arrange professional assistance for you immediately. By the time you put down the phone, our Service24h team will be getting ready to make their way to you. It will often be possible to sort out the problem at the scene. If this is not the case, however, we will of course arrange for your car to be taken to the nearest Mercedes-Benz workshop.

MercedesCard

Your ticket to the Mercedes-Benz experience: the quarterly MercedesCard ARGENTUM journal offers you an exclusive selection of exciting events starring the Mercedes-Benz brand. In addition, the Mercedes magazine is packed with gripping and inspiring articles and reports. The MercedesCard has many other functions: as a VISA credit card, it is an accepted form of payment worldwide – with no annual fee if you complete a questionnaire every year. In addition, it offers further benefits to put your mind at ease, such as the Mercedes-Benz insurance package, at no extra charge, and the exclusively compiled MercedesCard insurance package at a preferential rate. For further information about this offer, available exclusively to Mercedes-Benz drivers, visit www.mercedes-benz.de/mercedescard²

Mercedes-Benz Bank

If you have already chosen your dream car and want to remain financially flexible, the Mercedes-Benz Bank should be your next port of call. We are your one-stop shop for leasing, financing, insurance and service packages. By way of example, our “Private Leasing plus” scheme is a complete package comprising leasing, insurance and a purchase option, while our “Plus3” finance package combines low rates with high flexibility. That’s because, at the end of the contract, you decide yourself whether to keep your car, sell it or return it to us for a guaranteed price. We also offer an attractive range of investment products, including instant-access savings accounts, fixed-interest products and investment funds. For further information, please call us on 01803/32 22 65³ or visit us at: www.mercedes-benz-bank.de

¹ Freephone number, mobile-phone rates may vary

² Information about the MercedesCard in Austria and Switzerland can be found on the Mercedes-Benz websites for these countries

³ 9 ct/min from Deutsche Telekom landlines, mobile-phone rates may vary



Time for another enriching experience

A Mercedes-Benz is most at home on the road. This is the only way to experience the effortlessly superior driving feel that lends every model its inimitable class. Feel the power of the engine as it propels the car forwards. Marvel at the precise steering, designed to really put you in the mood for driving. And experience what true comfort really feels like. The unique feeling of driving a Mercedes cannot be put into words, however. Which is why we'd like to invite you to take a test drive. Your Mercedes-Benz dealer will be happy to make all the necessary arrangements for you. Simply visit www.mercedes-benz.com to locate the nearest Mercedes-Benz dealer in your country or region. We look forward to seeing you.

The website also offers an interactive tour, enabling you to take a closer look at your desired model. This simulation is the ideal way to acquaint yourself with your dream car. You can view key functions in detail, gain an insight into the car's inner workings or look at the benefits of each model. For further details, visit www.mercedes-benz.de/owners-manual

Now your mobile phone acts as a gateway to the whole Mercedes-Benz world. In addition to an overview of all passenger car models, there are insights into the entire brand world, not to mention a wealth of entertainment offers and direct links to a range of services at www.mercedes.mobi

Take-back of end-of-life vehicles. Coming full circle. At the end of its long life, you can return your SLK to us for environment-friendly disposal in accordance with the EC End-Of-Life Vehicle Directive¹. But that day lies a long way off.

¹ Applies in accordance with national regulations to vehicles up to 3.5 tonnes gross weight. Mercedes-Benz passenger cars have met the statutory regulations governing the suitability of their design for reuse and recycling for a number of years now. A network of vehicle take-back depots and dismantlers has been established which will process your vehicle in an environment-friendly manner. The ways in which both vehicles and parts can be recovered are subject to ongoing development and improvement. Consequently, the SLK will be able to comply with any future increases in the recycling quota within the stipulated time limits. For further information, call 00800 1 777 7777.

Please note: changes may have been made to the product since this brochure went to press (15.08.2008). The manufacturer reserves the right to make changes to the design, form, colour and specification during the delivery period, provided these changes, while taking into account the interests of the vendor, can be deemed reasonable with respect to the purchaser. Where the vendor or the manufacturer uses symbols or numbers to describe an order or the subject of an order, no rights may be derived solely from these. The illustrations may show accessories and items of optional equipment which are not part of standard specification. Colours may differ slightly from those shown in the brochure, owing to the limitations of the printing process. This brochure has been compiled by Daimler AG of Germany and is distributed internationally. It provides a general indication of the range of models, features, optional extras and/or colours available in various countries. Some of the models, features, optional extras and/or colours shown may not be available in your country or may only be available in a different specification. Additionally some models, features, optional extras and/or colours may only be available in combination with others. For current and more specific information in relation to the range of models, features, optional extras and/or colours available in your country, and their pricing, you should contact your nearest authorised Mercedes-Benz Passenger Car Dealer. www.mercedes-benz.com