



Actros

Cabins

Mercedes-Benz



Actros

Cabins



Design and construction

All Actros cabs are specified in line with operational requirements. Each cab offers superb driver comfort and safety along with practical features designed to make life on board as pleasant as possible.

Actros cabs are constructed of steel and precision welded by robots. Critical areas are galvanised and box sections are filled with wax. This gives excellent protection against corrosion and offers high standards of occupant safety (complying with ECE-R29).

Cabs tilt to 70° to enable optimal service access, either using the manual or electric pump where fitted.

Comfort

Driver comfort was one of the primary objectives when designing the Actros cab and it has been improved even further. All the seats and beds are designed to offer unrivalled support and comfort.

The upper bed (where fitted) features our unique adjustable spring slats and at a massive 800 mm x 2,020 mm, it gives the most comfortable night's sleep possible. Thanks to a newly designed suspension system, the height of the front edge of the upper bed can be adjusted so that the driver always sleeps level.

The lower bed now also features our unique adjustable spring slats and gives a generous 710 mm x 1,950 mm sleeping area. The lower bed features a new rising head section to optimise driver comfort when relaxing in the cab.

The driver's seat is air suspended with a head restraint and armrests. It is extensively adjustable and provides ideal support and positioning for the driving controls.

The passenger's seat features a lifting squab allowing either cross cab access or additional space for storage or movement.

All of the materials used in the Actros cab have been specially selected to deliver a high-quality look and feel throughout the vehicle's life.

Storage

The storage areas in the Actros are both practical and accessible. For smaller items there are deep pockets on each door, recesses on the fascia and above the windscreen, dual drinks holders for driver and passenger are also integrated into the fascia.

For larger items, sleeper cabs feature a large pull-out drawer under the lower bed, which can be optionally fitted with a fridge. MegaSpace cabs are fitted with two large drawers as standard.

Long cabs feature two large secure compartments for storage accessible from inside and outside the cab. MegaSpace cabs also have additional external storage compartments.

Access

Getting in and out could not be easier. Doors open to 90° and two grab handles aid entry. The non-slip entrance steps are illuminated and arranged in a staircase for safe entry and exit.

Interior lighting

Interior lighting is supplied by fully dimming lamps positioned around the cab. These can be controlled by the door opening and will automatically turn off once moving. The Actros also has reading lamps and green night lamps.

Instruments

The new anti-glare instrument cluster gives the interior a very modern feel and a quick glance gives all the information necessary for safe driving. More detailed information is obtained by scrolling through the information pages using the function buttons on the steering wheel. The fuel gauge includes an integrated AdBlue tank level indicator.

Protection and finish

Actros cabs are painted in Arctic White as standard and can be ordered in a range of solid or metallic colours. Please see your local Mercedes-Benz dealer for full details.

Chassis and components are finished in Nova Grey whilst the wheels are painted silver.

Service access

Lifting the front grille gives access to top up the following fluids

- Clutch
- Screen wash
- Coolant
- Engine oil

All fluids can be monitored through the Telligent® Maintenance System.

Other refinements

Two electrically adjustable, large rearview mirrors with switched heating combined with long-range mirrors on both sides, ensure all-round visibility.

Two full width sunvisors at the front on all cabs and a pull down window blind on the driver's side on long cabs are fitted as standard. Externally all round tinted glass and an impressive new sunvisor are also standard.

Three point integrated seat belts.

Dash mounted 12 volt socket.

Electric windows for driver and passenger - operated from door panel.

Cab mounted compressed air gun.

Automatic rain and light sensors.

Steering wheel control buttons.

Short cab

The short cab is specially designed for minimised cab space to maximise payload space behind cab.

Cab exterior

- Three piece steel front
- Swinging bottom step with steel bumper
- Windows in cab rear wall
- Rain sensor and automatic driving lights

Cab interior

- Stereo CD player with Bluetooth connectivity
- Hardwearing woven cloth seat fabric
- Compressed air connection in cab with air gun
- Driver's airbag and seatbelt pre-tensioner (not with off-road vehicles)

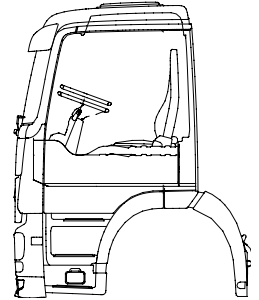
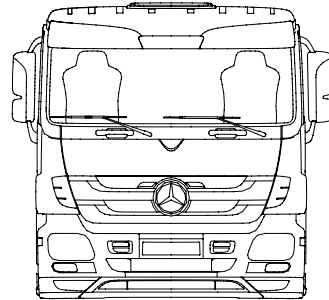

Mid cab

Available with all models, distribution style cab with some storage space behind the seats.

Cab exterior

- Aerodynamic front bumper (three piece steel with off-road vehicles)
- Cab access via 3 stairs (swinging steps with steel bumper)
- Windows in cab rear wall
- Rain sensor and automatic driving lights

Cab interior

- Stereo CD player with Bluetooth connectivity
- Hardwearing woven cloth seat fabric
- Compressed air connection in cab with air gun
- Driver's airbag and seatbelt pre-tensioner (not with off-road vehicles)

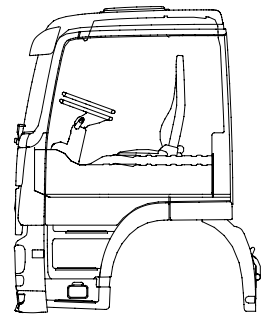
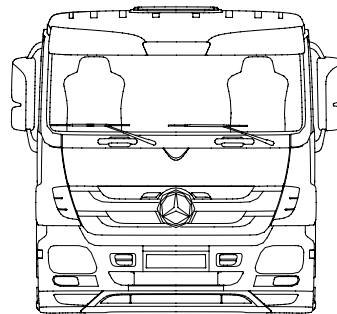

Long cab

The cab of choice for prime-movers, designed for the long haul with comfort bed and plenty of storage.

Cab exterior

- Aerodynamic front bumper
- Cab access via 3 stairs
- Extended rear cab wall
- Remote central locking
- Electric sunroof
- Storage lockers on both sides
- Aerodynamic fairing and side extenders optional
- Electric cab tilt pump
- Rain sensor and automatic driving lights
- Low roof option

Cab interior

- Stereo CD player with Bluetooth connectivity
- Hardwearing woven cloth seat fabric
- Compressed air connection in cab with air gun
- Driver's airbag and seatbelt pre-tensioner
- Luxury bed with compartment draw underneath
- Storage compartments above windscreen
- Driver's side sunblind
- Wood-grain dash

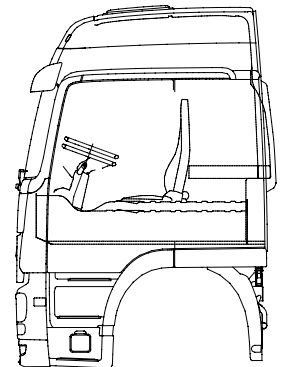
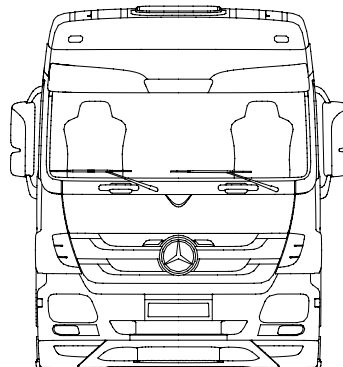

MegaSpace cab

The top of the range long haul cab with comfort bed, extra storage and designed for easy movement inside the cab with a flat floor.

Cab exterior

- Aerodynamic front bumper
- Cab access via 4 stairs
- Extended rear cab wall
- Remote central locking
- Electric sunroof
- Storage lockers on both sides
- Aerodynamic fairing and side extenders optional
- Electric cab tilt pump
- Additional storage lockers
- Fog lights in bumper
- Rain sensor and automatic driving lights

Cab interior

- Stereo CD player with Bluetooth connectivity
- Hardwearing woven cloth seat fabric
- Compressed air connection in cab with air gun
- Driver's airbag and seatbelt pre-tensioner
- Luxury bed with 2 compartment draws underneath
- Storage compartments above windscreen
- Driver's side sunblind
- Wood-grain dash

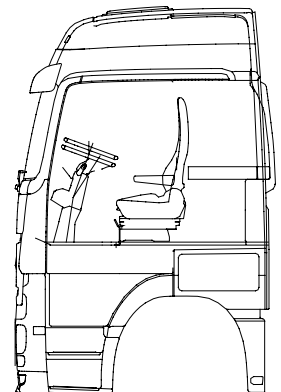
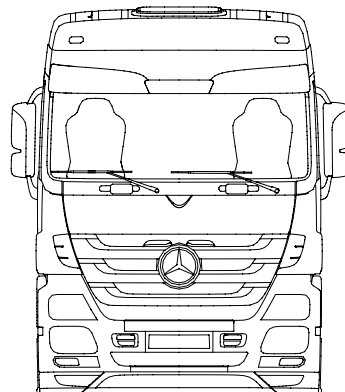

Factory fit cab options

Cab exterior	Short	Mid	Long	MegaSpace
Front fog lights	○	○	○	●
Roof air deflector	○	○	○	○
Roof and side air deflectors	○	○	○	○
Electric glass sun roof	—	○	●	●
Electric cab tilt (not with steel bumper)	○	○	●	●
Automatic headlamp and wiper activation	●	●	●	●
Bi-Xenon headlamps	○	○	○	○
Cab rear window	●	●	○	○
Safety package	○	○	○	○
Fuel saving A-pillar	○	○	○	○
Low roof cab	—	○	○	—
Air horns on roof	○	○	○	○
Painted grille	○	○	○	○
Painted cab mounted parts	○	○	○	○
Cab interior	Short	Mid	Long	MegaSpace
Driver's airbag (not with off-road vehicles)	●	●	●	●
Air conditioning	●	●	●	●
Air suspended comfort seat - Driver	●	●	●	●
Air suspended comfort seat - Passenger	○	○	○	○
Centre seat	○	○	—	—
Remote central locking	○	○	●	●
Provision for phone or fax	○	○	○	○
CD storage box	○	○	●	●
12V socket in dash	○	○	○	○
Refrigerator in under-draw bunk	—	—	○	○
Passenger sunblind	○	○	○	○
Lower bunk	—	○	●	●
Upper bunk	—	—	○	○

Key: Standard ● Optional ○ Not available —

Authorised Dealer

To speak to your nearest authorised Mercedes-Benz Dealer call **1300 66 22 30**

Mercedes-Benz Australia/Pacific Pty Ltd offers a standard 3 year / 450,000 km or extended 4 year / 800,000 km driveline Warranty on engine, transmission, propshafts and driving axles. For full Warranty details and limitations contact your authorised Mercedes-Benz Dealer. Specifications and information referred to herein is correct at the time of publication. Some of the equipment depicted either on vehicle illustrations or separately may be non-standard or optional at extra cost. Mercedes-Benz Australia/Pacific Pty Ltd reserves the right to discontinue or modify any vehicle or optional equipment at any time without prior notice to meet any requirement of a manufacturing or commercial nature which it may deem appropriate. Consult your authorised Mercedes-Benz Dealer for the latest details on specifications, options, prices and availability. www.mercedes-benz.com.au/trucks Telligent® is a registered trademark of Daimler AG. LMCT 6776 Mercedes-Benz Australia/Pacific Pty Ltd, ABN 23 004 411 410. 44 Lexia Place, (PO Box 4214) Mulgrave, Victoria 3170 Telephone: (03) 9566 9317 Facsimile: (03) 9562 0397. The  and the words Mercedes-Benz are registered trademarks of Daimler AG, Germany. Printed in Australia. MBB011 01/09.