



This Brochure is prepared by Daimler AG and it predominantly reflects the capabilities and performance of vehicles sold in Europe. Some characteristics, capabilities, performance features and optional extras (e.g. towing systems) may not be available or may not apply in Australia or under Australian conditions. The information in this Brochure is therefore indicative, illustrative and provided only for guidance and should not be relied on. To obtain current and accurate information on a vehicle and any options applicable to Australia, contact your local authorised Mercedes-Benz dealer.

Mercedes-Benz

The CL-Class



Mercedes-Benz

neering too. Its dynamic design takes your breath away with a magical allure
which the boldest visions of our engineers and designers are brought together
for a car so effortlessly. Meet a car that is your equal – and every bit as discerning
that reflects the pinnacle of what is achievable rather than extravagance.
ahead thanks to its new driving assistance systems. It slips through the wind
as you glance from one new thrilling detail to another. Sheer passion tamed
its dynamism is infectious. One look is all it takes. Isn't it reassuring to be
complete trust. If the CL had a favourite tense, it would be the future tense.
t of surprise. **Excellence in a brand new form.** Style, skill and sophistication
e an unforgettable impression. And it is the coupé you'll have already seen



Not only is the CL a paragon of elegance and luxury, it's a masterpiece of engineering too. The new generation of V8 engines with BlueDIRECT technology sets new standards of efficiency and performance. Meanwhile, an array of sensors and intelligent electronic systems help to make the new CL even safer and more comfortable.

Its dynamic design takes your breath away with a magical allure that enchants anyone, no matter how high their expectations are. At the essence of the CL is the resolve to keep improving, even when perfection has been reached. And that is precisely what makes it so special: excellence in a brand new form.

[Overview](#) | [from page 4](#) [Insight](#) | [from page 28](#)

The CL-Class

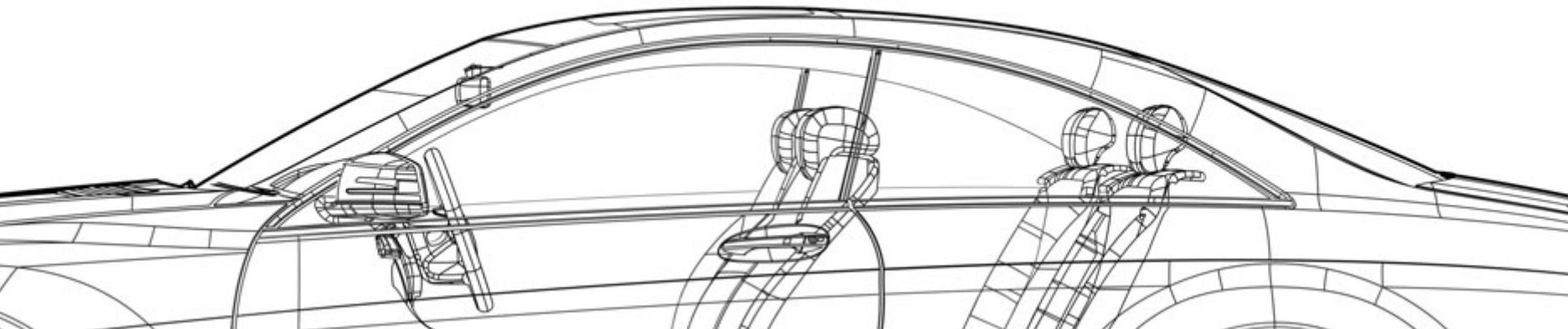

Dynamism at its best: engines, transmissions and chassis.

Drive system & chassis | from page 36

Supreme safety: innovations and proven technologies which can act in advance to help prevent accidents, mitigate their possible consequences and facilitate rescue.

Safety | from page 44

Relaxation en route: all you need to know about the entertainment, multimedia and assistance systems, climate control and seating comfort.

Comfort | from page 48

The right CL for any situation:

CL 500 BlueEFFICIENCY, CL 500 4MATIC BlueEFFICIENCY and CL 600.

Model variants | from page 54

Mighty AMG coupés: the CL 63 AMG and CL 65 AMG models.

AMG | from page 58

A coupé with personality: standard equipment and optional extras, designo, upholstery and trim, light-alloy wheels and genuine accessories.

Equipment | from page 64

Star-studded service: everything there is to know about the Mercedes-Benz Museum and services.

Services | from page 80

CL in detail: dimensions, paintwork and technical data.

Facts & colours | from page 82



Making prowess a way of life:

We have a long tradition of building outstanding coupés – and the CL is yet another extra-special one. It is the coupé in which the boldest visions of our engineers and designers are brought together in spectacular fashion. It is the coupé which perpetuates the evolution of the motor car so effortlessly. And it is the coupé you'll have already seen so many times in your dreams.

Masterfulness

A top-class means of travel
for top-class achievers:

Style, skill and sophistication: the CL blends vivid design,
true craftsmanship and leading-edge technologies to
make an unforgettable impression. Meet a car that is your
equal – and every bit as discerning.

Effortless superiority





**Eliminating the element
of surprise:**

With the optional 4MATIC permanent all-wheel drive, you will be accompanied on every journey by a system that dutifully distributes the drive torque to all four wheels and makes your car feel more like your travel companion. The result is even greater traction and handling safety, no matter whether you are driving over asphalt or sand, in the wet, through snow or on black ice. Yet another detail of a car that is truly deserving of your complete trust.

Predictability









A marriage of courage and respect:

Creating a truly moving experience requires unwavering commitment. That is why the CL incorporates only the very finest of traits: consistent style, absolute dedication and advanced environmental technologies. With impressive results: CO₂ emissions in the CL 500 BlueEFFICIENCY have been cut by 22%. Luxury that reflects the pinnacle of what is achievable rather than extravagance.

Responsibility











S PB 5585



**A staggering feat
of innovation:**

If the CL had a favourite tense, it would be the future tense. Because instead of concentrating on the here and now, it thinks a few possibly crucial seconds ahead thanks to its new driving assistance systems. Innovations such as Active Lane Keeping Assist and Active Blind Spot Assist, both of which are available as options, can thus help to prevent hazardous situations.

The power of invention





When two eyes are
not enough:

It slips through the wind but cannot escape the wondrous gaze of all around: the CL has a more mature, more dynamic and even more harmonious feel about it. The radiator grille's two striking louvres set the tone, the bonnet's four bold lines make it appear to be straining forward, the tail seems wider. It's hard to believe your eyes as you glance from one new thrilling detail to another.

Harmony











Radio interface display showing:
Navi Audio Telefon Video Fahrzeug
FM 102.7 MHz
- 103.5 MHz
102.7 MHz - 107.5 MHz
- 102.3 MHz - 105.5 MHz
Radio Speicher Info FM Klang





A breathtaking sense of speed,
even at standstill:

The character of the CL lives up to all the promise of its distinctive appearance: sheer passion tamed by elegance. Flowing lines exude power, while luxurious materials seduce the senses. And its dynamism is infectious. One look is all it takes.

Spirit



Peace of mind in the midst of the storm:

You are always assured of its undivided attention, which is why the CL is able to nip critical situations in the bud. There is ATTENTION ASSIST, for example, which tracks your steering reactions and gives you a gentle but firm warning if drowsiness sets in. Isn't it reassuring to be able to trust something so much?

Trust





The manual revolution

27 bones, 33 muscles, 3 nerves, 17,000 nerve endings and a unique sensitivity to the world around it – the human hand is the most reliable tool we know. Making it the only one that is good enough to build the CL.

90% of the steps involved in the assembly of the CL are carried out just by hand without the use of machines, with some even requiring the very finest craftsmanship. There are just two robotic stations for installing the windscreen, rear window and the cockpit. A handpicked team of mechanics work with the utmost precision to make sure that every component and piece of trim fits perfectly and every last stitch is flawless. In the process, our employees always add a very special ingredient that no machine could ever emulate: the pride they take in yet another masterpiece from Mercedes-Benz.

Our very first assistance system

In the early days of motoring, cars were often regarded as mechanical monsters that were full of mysterious technology and difficult to control. Steering them required a great deal of physical effort, while their day-to-day operation called for highly specialist knowledge. This prompted the Daimler-Motoren-Gesellschaft to occasionally supply its cars complete with true experts. Not only did they deliver the cars, they also showed the affluent clientele how to operate these technological marvels. They furthermore assumed the combined role of mechanic, chauffeur and travel companion – sometimes for weeks or even months.

One such expert was Rudolf Schwarz, who was born in Ludwigsburg in 1878. Cool-headed, highly reliable and an employee who was held in great esteem by Gottlieb Daimler himself, he was in effect one of the very first assistance systems for making motoring safe. Today, there are more than a dozen various assistance systems in the CL helping to ensure every journey is nothing but an absolute pleasure.



t 8/V 7G-TRONIC for V8 engines Night View Assist Plus Adaptive Highbeam
/5250 Active Body Control including crosswind stabilisation CL 63 AMG C
e Acceleration from 0-100 km/h (s) AMG SPEEDSHIFT MCT 7-speed trans
ce package Plus Torque Vectoring Brakes CL 500 4MATIC BlueEFFICIENCY
232 Tyre size front/rear 255/35 R 20/275/35 R 20 COMAND APS CO₂ emis
ST Light-alloy wheels SPLITVIEW 12-cylinder engine 5-speed automatic tra
ed automatic transmission Speed Limit Assist Active Body Control (ABC) 4M
PLUS V12 Active suspension system V8 engines Generator management wi
45 R 18 tyres **The facts** Ambient lighting in three tones The 15-spoke light-
RECT technology 255/40 R 19 at the front and 275/40 R 19 at the rear Elect

36 **BlueEFFICIENCY**37 **CL-Class with BlueDIRECT technology**38 **Petrol engines**

V8 engines

V12 engines

40 **Transmissions**

7G-TRONIC

5-speed automatic transmission

42 **Chassis**Active Body Control (ABC)
including crosswind stabilisation
4MATIC44 **Safe driving**

ATTENTION ASSIST

Adaptive Highbeam Assist

Night View Assist Plus

Driving Assistance

package Plus

Torque Vectoring Brakes

46 **In the event of danger or an accident**

Airbags

PRE-SAFE® system

PRE-SAFE® Brake

48 **Multimedia systems**

COMAND APS

SPLITVIEW

Harman Kardon® Logic 7®

surround sound system

50 **Assistance systems**

Reversing camera

PARKTRONIC including

Parking Guidance

Speed Limit Assist

52 **Climate control**53 **Seats**

Active multicontour seats

Climatised front seats

54 **CL 500 BlueEFFICIENCY**55 **CL 500 4MATIC BlueEFFICIENCY**56 **CL 600**

The CL-Class in detail

58 **CL 63 AMG**

60 **CL 63 AMG technology**
 AMG 5.5-litre V8 engine
 AMG SPEEDSHIFT MCT
 7-speed sports transmission

62 **CL 65 AMG**

64 **Standard equipment**

65 **Optional extras**

66 **AMG Sports package**

68 **designo**

70 **Upholstery and trim**

76 **Wheels**

78 **Genuine accessories**

80 **Services**

Mercedes-Benz Museum

MercedesCard

Mercedes-Benz Bank

Mercedes-Benz mobility

Test drive

Service packages

Interactive Owner's Manual

Mobile internet

82 **Dimensions**

82 | 85 **Paintwork**

83 **Technical data**

BlueEFFICIENCY – fast forward to tomorrow



We do not pay lip service to protection of the environment. It's a matter close to our hearts. By the end of 2010, we will be able to offer you 85 models with BlueEFFICIENCY technologies, all of which place far less of a burden on the environment. Our BlueEFFICIENCY concept comprises innovations for efficient mobility as well as optimised processes all the way along the value chain.

BlueEFFICIENCY measures – the Mercedes-Benz efficiency package. The BlueEFFICIENCY measures are comprehensive vehicle optimisations which ease the burden on the environment. Each model combines the most efficient engine with the latest aerodynamic and energy-management measures, including the ECO start/stop function, which is being made available for an increasing number of models. Our new V8 petrol engines in the CL-Class, for example, reduce fuel consumption by up to 20% yet have a much higher power output.

BlueTEC – the clean diesel. A modular emission-control system makes BlueTEC an exceptionally clean diesel technology. As well as removing 95% of the particulate, it also reduces nitrogen oxides by up to 90%. What remains is mainly water and harmless nitrogen.

HYBRID – the intelligent combination of petrol and electric drive. During braking, the electric motor acts as a generator, turning the kinetic energy into electrical energy and feeding it to the battery. This energy is then available when needed. What's more, the ECU shuts off the petrol engine when the speed falls below 15 km/h. In this way, a HYBRID can reduce fuel consumption by up to 20%.

BlueTEC HYBRID – clean diesel combined with electric drive. From 2011, BlueTEC HYBRID will marry the benefits of the HYBRID with those of BlueTEC: during braking, kinetic energy is converted into electrical energy, which can be reused when required. At the same time, the

BlueTEC technology cleans the exhaust gases and removes a large part of the pollutants, making the economical diesel powerplant even more efficient and clean.

Innovative drive systems that break new ground: E-CELL and F-CELL. We have developed two locally emission-free drive systems that will be produced on a small scale and delivered to customers around the world starting in 2010. The B-Class F-CELL uses hydrogen to produce power for the electric motor, while the A-Class E-CELL draws its energy from a battery alone.

But that is not all: under the banner "Design for Environment", we also look at a vehicle's entire lifecycle and work hard to preserve the environment from the planning stage right through to recycling. In addition, we are involved in the development of alternative fuels and carry out research in the field of bionics. Further information about our comprehensive measures can be found at www.mercedes-benz.com/blueefficiency

CL-Class with BlueDIRECT technology

The CL-Class has always been a car whose technology sets new standards. Consequently, it also leads the way when it comes to measures aimed at reducing fuel consumption and emissions. It also boasts an outstanding drag coefficient.

When we develop a new model, responsibility for the environment plays a crucial role. People's awareness is increasing as emissions, fuel consumption and fuel prices become

topics that affect us all. It is therefore only natural that there are also CL-Class BlueEFFICIENCY models. And, far from being just a vision of a clean environment,

BlueEFFICIENCY incorporates a whole raft of specific measures:



- 1 ECO start/stop function in the CL 500 BlueEFFICIENCY/ CL 500 4MATIC BlueEFFICIENCY and CL 63 AMG
- 2 New BlueDIRECT generation of V8 engines incorporates measures such as downsizing, direct petrol injection, two compact turbochargers for spontaneous response and intercooling for optimised thermodynamic efficiency
- 3 Sealed joints around the headlamps for improved aerodynamics
- 4 Optimised 7G-TRONIC for V8 engines
- 5 Euro 5 certification for entire engine range
- 6 Generator management with braking energy recuperation (V8 engines)
- 7 Aerodynamically styled exterior mirror housings
- 8 Energy-saving control of auxiliary units for V8 engines (power steering pump as well as oil and water pumps)
- 9 Specially designed tyres for lower rolling resistance

Petrol engines

The BlueDIRECT petrol engines for the new CL combine intense driving pleasure with eco-friendly operation more effectively than ever. Consequently, the state-of-the-art V8 engine in the CL 500 BlueEFFICIENCY sets new standards for efficiency and performance with its direct fuel injection and twin turbochargers.

V8 engines. The drive unit from the new BlueDIRECT family of Mercedes-Benz engines has been developed from scratch and is making its debut in the new CL 500 BlueEFFICIENCY. On the one hand, it excels with a fuel consumption that is 22% lower than on the predecessor model – with a corresponding reduction in emissions. This is the result of lightweight design measures throughout, a moderate degree of downsizing to a displacement of 4.7 litres, direct injection with ultra-precise piezoelectric injectors, plus forward-looking BlueEFFICIENCY technologies. The ECO start/stop function, for instance, is designed to temporarily shut off the engine when stopped at lights or in traffic. On the other hand, its performance credentials have been given a significant boost by the twin turbochargers

and intercooling. A power output that has been upped to 320 kW, a substantially higher torque of 700 Nm on tap from just 1800 rpm, plus improved acceleration promise effortlessly superior motoring in any situation. And the new V8 engine proves supreme when it comes to emissions efficiency too by meeting the Euro 5 standard.

V12 engines. It's the crème de la crème of all engines – with silky smooth running, spontaneous power and a superlative sound. Yet it is also highly efficient, technically innovative and, by complying with the Euro 5 emissions standard, ecologically sound. The V12 biturbo's peak torque of 830 Nm is on tap even before the 2000 rpm mark has been reached. The CL 600 powers from 0 to 100 km/h in just 4.6 seconds, with the

V12 generating 380 kW with the help of its twin turbochargers and intercooling.

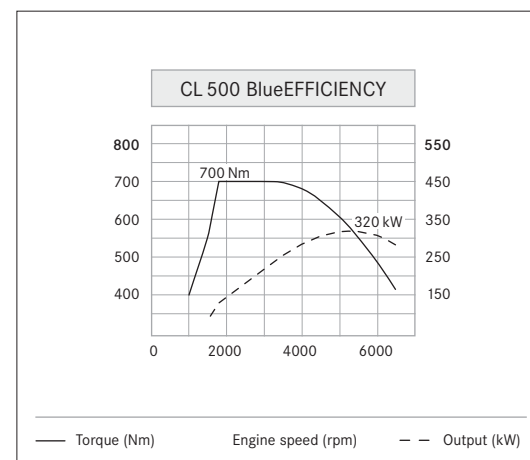

The CL 500 BlueEFFICIENCY: cutting-edge engine technology with piezoelectric direct injection



The V8 engines are the first derivatives of the new BlueDIRECT family of engines from Mercedes-Benz

Transmissions

Whatever your driving style – economical or sporty – the transmissions for the CL have been optimised with your needs firmly in mind

7G-TRONIC. The V8 engines are paired with the newly refined Mercedes-Benz 7-speed automatic transmission as standard. The 7G-TRONIC is controlled using the DIRECT SELECT lever on the steering column. The seven forward gears maintain optimum revs at all times, thus reducing both fuel consumption and noise levels. The minimal shift times and seamless transitions also make for excellent acoustic comfort as well as wonderfully smooth gearshifts. A set-up switch enables the driver to choose from three different shift modes: Manual, Comfort or Sport. Manual gear-

shifts are performed using paddles on the steering wheel – just like in Formula 1.

5-speed automatic transmission. This transmission is perfectly suited to the twelve-cylinder engine's characteristics – gear changes are so fast and smooth that they are barely perceptible, while just the right amount of power is delivered for every situation. Drivers can again change gear manually if the optional steering-wheel gearshift paddles are specified.



Fingertip transmission control with the DIRECT SELECT lever on the steering wheel

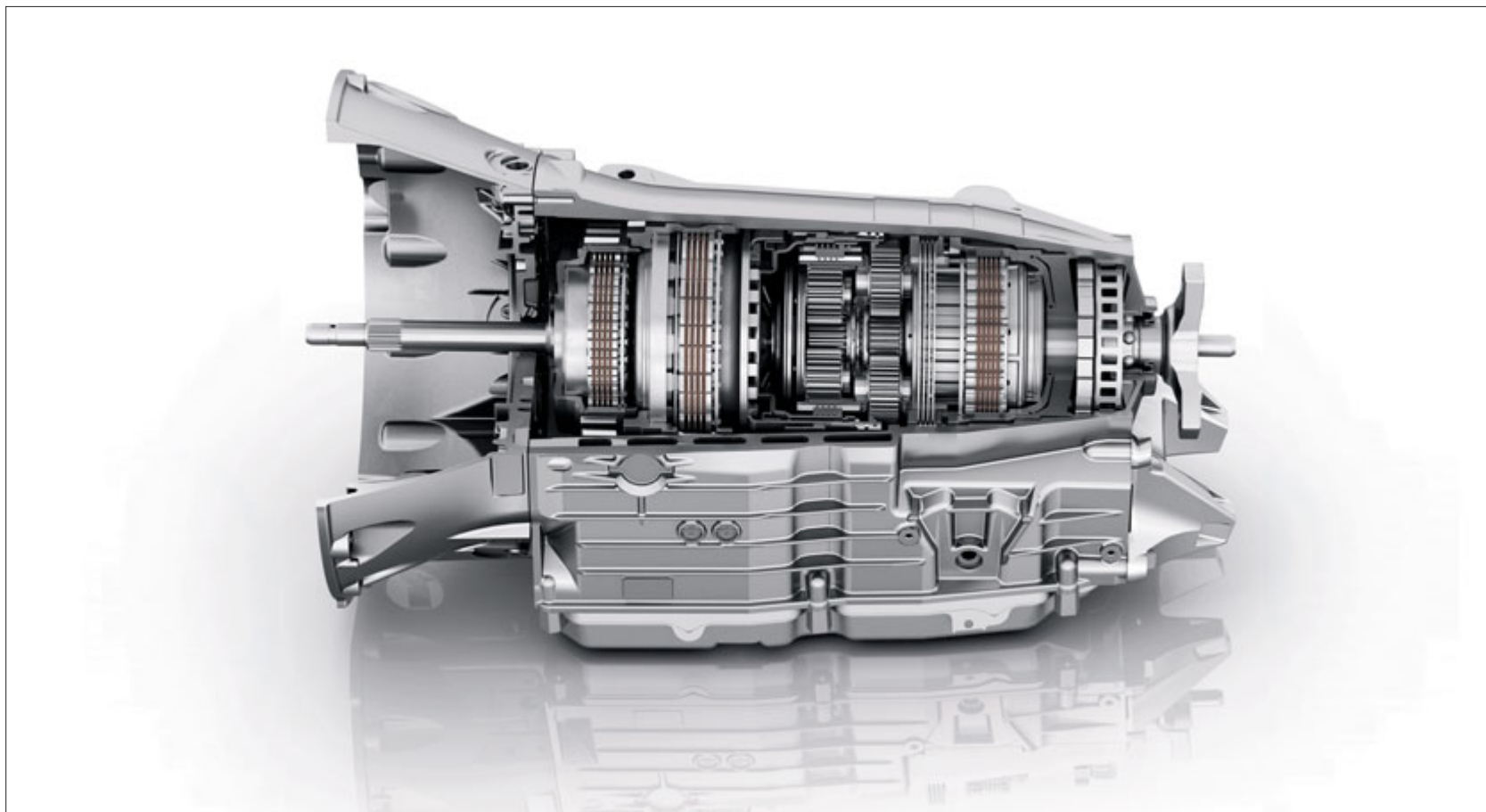

7G-TRONIC: one of over eleven million automatic transmissions produced in a period spanning more than 40 years

Chassis

Comfort is omnipresent – thanks to precision-tuned chassis and suspension components plus the option of powerful all-wheel drive

Active Body Control (ABC) including crosswind stabilisation (standard on all models except CL 500 4MATIC BlueEFFICIENCY which comes with AIRMATIC as standard). The active suspension system can provide both a comfortable and an agile ride as its set-up can be adapted as required in an instant. Microprocessor-controlled suspension struts compensate for the car body's

lift, pitch and roll by selectively raising or lowering the suspension to counteract these movements. The same process is employed to reduce body movements when the CL pulls away or brakes. The AIRMATIC air suspension with adaptive shock absorbers also adjusts itself to suit the current road conditions, vehicle load and driving situation exactly. The driver is furthermore

able to choose between a more comfort-oriented or a sporty setting manually. Crosswind stabilisation, meanwhile, can compensate for the effect of crosswinds by distributing the wheel load accordingly, and helps to keep the vehicle on course, even in stormy weather.

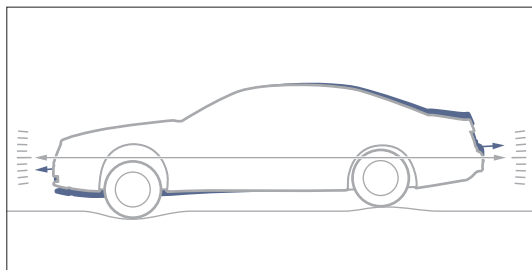

The AIRMATIC air suspension combines effortlessly superior roadholding with a high degree of comfort

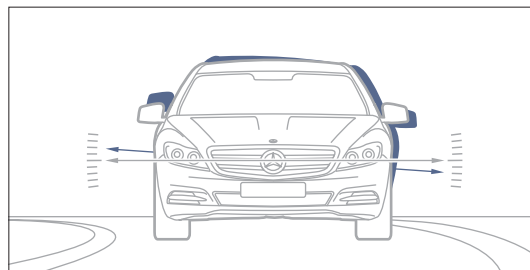

ABC ensures an extremely agile and dynamic driving feel, while crosswind stabilisation improves handling by actively influencing the wheel forces

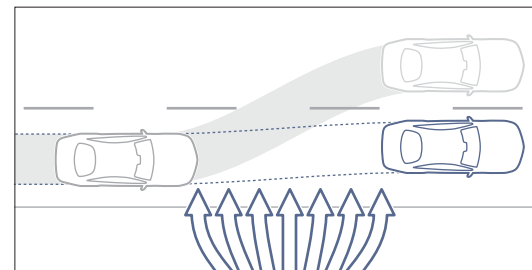

4MATIC. The permanent all-wheel-drive system splits the engine power between the two axles at a fixed ratio of 45% to 55% – for 100% traction. To this end, 4MATIC utilises the Electronic Stability Program ESP® as well as the electronic traction system 4ETS. The latter enables controlled braking of spinning wheels at the same time as increasing the drive torque at the wheels

with good grip. This allows plenty of power to be planted on the road when moving off and when accelerating, especially on poor road surfaces. Automatic braking pulses make it easier to move off on slippery surfaces as well as enhancing stability during critical manoeuvres. A further advantage of the system is the fact that it is hardly any heavier than the rear-wheel-drive

version on account of the compact design, intelligent choice of materials and high level of efficiency. 4MATIC is only available in conjunction with the 7G-TRONIC automatic transmission, meaning that it is not an option for the 12-cylinder or AMG models.

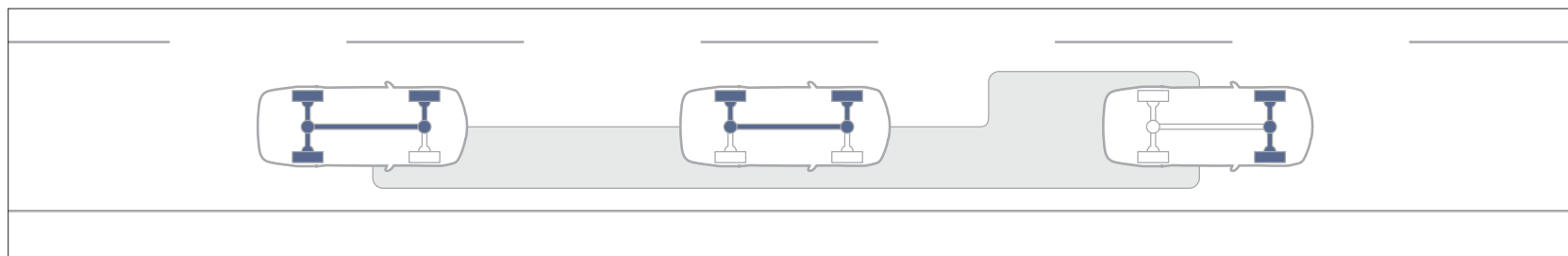

The electronic traction system 4ETS automatically directs the drive torque to the wheels with sufficient grip

Safe driving

The assistance systems in the CL help to detect and defuse critical situations and, therefore, prevent accidents wherever possible

ATTENTION ASSIST (standard). This new drowsiness detection system is useful on long trips. At speeds of between 80 and 180 km/h, ATTENTION ASSIST can alert the driver as soon as it detects lapses of attention. Several sensors are used to analyse driving behaviour on a permanent basis and detect telltale signs of drowsiness, such as involuntary steering movements.

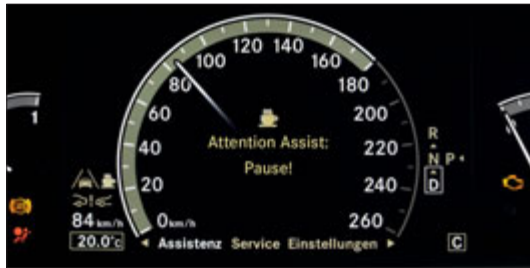

If ATTENTION ASSIST detects signs of drowsiness, it advises the driver to take a break

Adaptive Highbeam Assist (standard). Adaptive Highbeam Assist ensures excellent visibility at night time too without dazzling oncoming traffic or vehicles in front. By constantly optimising the headlamp range, it allows the driver to discern the line of the road, pedestrians or any danger spots earlier and more clearly.

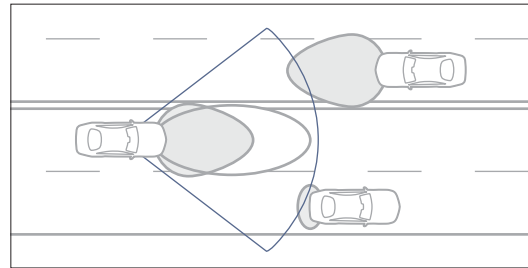

The low-beam headlamps have a range of up to 300 metres with Adaptive Highbeam Assist

Night View Assist Plus (optional). The infrared camera at the heart of this system scans the entire area normally covered by the high beam and displays it in the instrument cluster in the form of a greyscale image. Any persons detected are furthermore highlighted, enabling the driver to react more quickly to potential dangers when necessary.



Night View Assist Plus makes it easier to spot pedestrians ahead

Driving Assistance package Plus (optional).

This package's features include the new Active Lane Keeping Assist, which alerts drivers when they unintentionally drift out of lane with a gentle vibration of the steering wheel. Should they fail to react, the vehicle's course can be corrected with a controlled application of the brakes. For safer lane changing, there is Active Blind Spot Assist. When a vehicle is

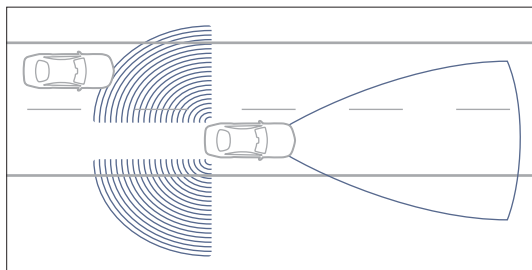

Active Lane Keeping Assist and Active Blind Spot Assist can warn the driver in potentially dangerous situations

detected in the blind spot, a red warning triangle lights up in the exterior mirror. Should the driver indicate to change lane anyway, an audible warning will sound too. If this is also ignored, the subsequent application of the brakes could prevent a possible collision. DISTRONIC PLUS helps the driver to keep at the pre-set distance from the vehicle in front. Finally, the PRE-SAFE® Brake is able to brake the vehicle automatically



Active Blind Spot Assist increases safety when changing lanes

in several stages prior to an impending rear-end collision.

Torque Vectoring Brakes (standard). This innovation enhances both handling safety and driving dynamics. If the ESP® detects understeer, the rear wheel on the inside of the bend is braked, turning the CL into the bend in a precise, controllable manner.

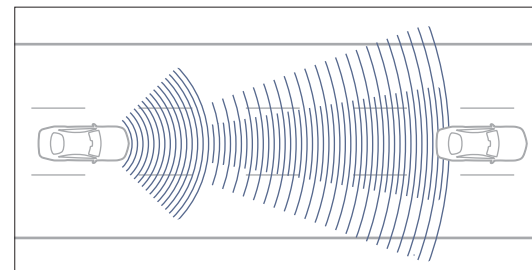

DISTRONIC PLUS maintains a set distance between the car and the vehicle in front

In the event of danger or an accident

Whether a collision is imminent or no longer avoidable, numerous systems have been developed for the CL to afford its occupants even greater protection

Airbags (standard). Airbags have been fitted as standard in all Mercedes-Benz passenger cars since October 1992. The CL comes equipped with a total of eight airbags, which can help to largely prevent injuries to both driver and passengers in a collision. Front airbags with two-stage deployment come as standard, as do sidebags in the front seat backrests and two windowbags that extend over both the front and rear seats. Plus, there are rear sidebags fitted under the wheel-arch trim to protect passengers in the rear. A great deal of development work likewise went into the new airbag control unit, which is capable of also factoring in critical approach speeds prior



A total of eight airbags can protect you and other passengers in the event of an accident

to a collision on models suitably equipped with short-range sensors.

PRE-SAFE® system (standard). The anticipatory occupant protection system, which Mercedes-Benz itself invented, is able to detect certain critical driving situations in advance and initiate precautionary measures. If a collision is deemed to be imminent, the system can close the side windows and sliding sun-roof, move the front passenger seat into a more favourable crash position and tension the seat belts automatically. If the optional active multicontour seats are fitted, the chambers

in the side bolsters can be inflated to brace the occupants laterally.

PRE-SAFE® Brake (optional as part of the Driving Assistance package Plus). This feature provides the driver with visual and audible warnings when it detects signs there is an imminent risk of a rear-end collision. If the driver fails to respond, it initiates autonomous partial braking (approx. 40% of braking power) and deploys PRE-SAFE® measures. The PRE-SAFE® system subsequently triggers autonomous emergency braking if required. As a result, impact speed and the severity of the accident can be reduced significantly.

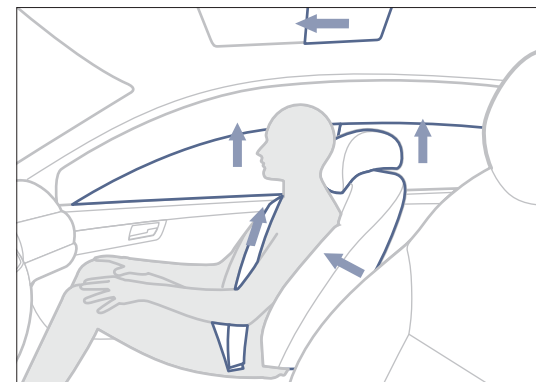

PRE-SAFE® helps to mitigate the consequences of accidents

Multimedia systems

In addition to the standard-fit USB, Bluetooth® and SD card interfaces, there is the option of SPLITVIEW and the Harman Kardon® Logic 7® surround sound system for superb in-car entertainment

COMAND APS (optional as part of the Navigation package). The multimedia system combines telephone, audio, video and hard-disc navigation, showing the information on a central colour display. The built-in DVD player can handle CDs and MP3 files, as well as playing video and audio DVDs. In addition, MUSIC REGISTER can store up to 2500 music tracks. Using Music Search you can search through this database by track



COMAND controller in the centre console

title or artist name, for example, to quickly find the music you want. The display shows maps – when navigating for instance – in 3D. COMAND APS receives European map updates free of charge for 3 years after the vehicle is first registered. Plus, there is LINGUATRONIC for simple voice control of a host of functions.

SPLITVIEW (optional as part of the Front Seat Entertainment package). SPLITVIEW is an innovative display technology that allows the driver and front passenger to each view a different picture on a single screen. While the driver looks at navigation information, for example, the front passenger can compile their own personal entertainment programme and listen through wireless headphones.



SPLITVIEW displays two different images at the same time – for the driver (1) and front passenger (2) – on a single screen

Harman Kardon® Logic 7® surround sound system (optional as part of the Front Seat Entertainment package). Excellent, further enhanced sound quality is provided by the Harman Kardon® Logic 7® surround sound system. It combines surround sound in Dolby Digital 5.1, a 13-channel DSP amplifier, 14 speakers specially tuned to the car's interior and a subwoofer. The 3D stereo sound is music to the ears, whilst the speed-sensitive volume control provides a consistent audio experience.

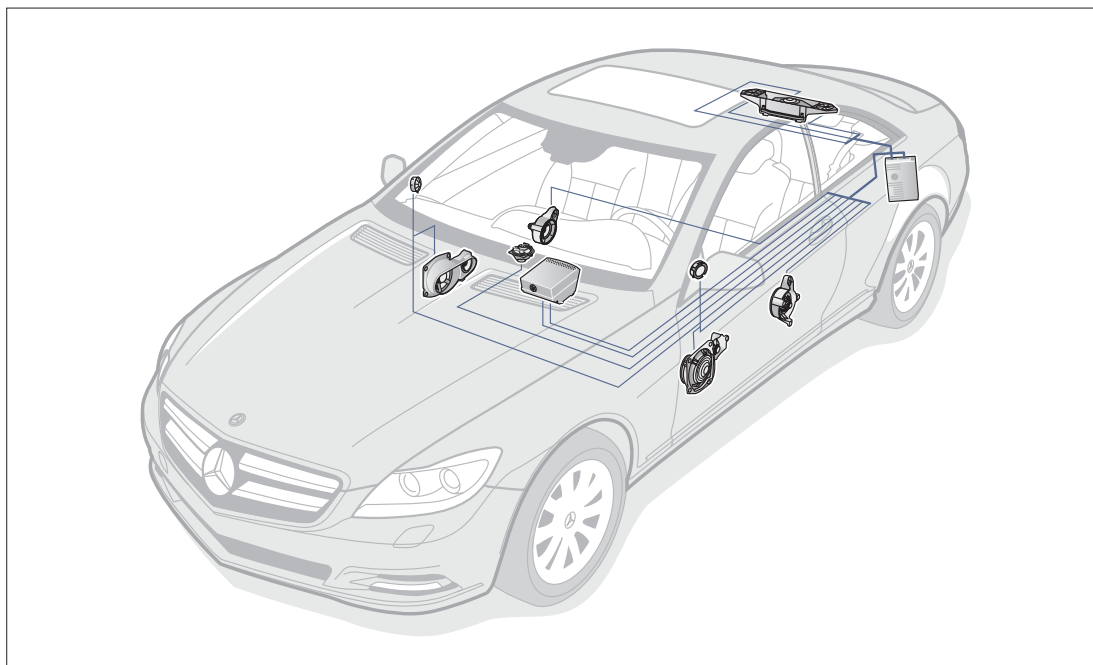

The Harman Kardon® Logic 7® surround sound system offer a first-class listening experience in the CL

Assistance systems

Numerous assistance systems help to enhance driving comfort and make life even easier for drivers of the CL



All-round visibility when parking and reversing – thanks to the optionally available reversing camera

Reversing camera (optional, standard for CL 600 and CL 65 AMG). The reversing camera assists the driver by affording a better view of the area around the rear of the car. A wide-angle lens is built into the boot handle. The reversing camera is activated automatically when reverse gear is engaged and sends its image of the area immediately behind the car to the COMAND display.

PARKTRONIC including Parking Guidance (standard). The Parking Guidance system measures parking spots automatically to help the driver first find a suitable space and then park in it. The readings from ultrasonic sensors are used to determine whether a parking spot is large enough. The parking situation is then shown on the multi-function display. Yellow markings on the display indicate the path that needs to be steered and

red markings the path currently being steered. When the two overlap, they turn green. The PARKTRONIC display furthermore indicates the current distance to obstacles.

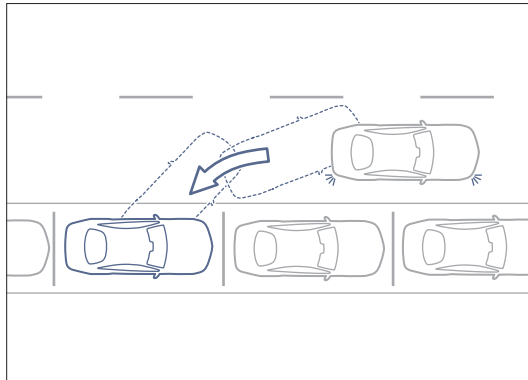

Parking Guidance provides parking instructions

Speed Limit Assist (optional as part of the Navigation package). A windscreen-mounted camera that permanently scans the car's surroundings is able to recognise signed speed limits and indicate the detected maximum speed to the driver in the display. The driver



Parking Guidance is easy to use

can therefore check the prevailing speed limit at any time. This added convenience is of particular benefit on routes with variable speed limits or roadworks.



Speed Limit Assist display in the instrument cluster

Climate control

A pleasant interior climate increases passenger comfort and driver-fitness safety aboard the CL

Automatic climate control (standard). The automatic climate control system allows the driver and front passenger to adapt the climate in their respective seats to suit their personal requirements independently of one another, and maintains



Preferred temperatures can be set individually at the push of a button

the temperature at the desired level automatically. There is a solar sensor on the windscreen, for example, to monitor the intensity and direction of the sun's rays. There is a separate control for varying the front footwell temperature in relation



Climate control function in COMAND

to the rest of the interior. Further standard features include air recirculation, a cooled glove compartment, plus the combination dust and activated charcoal filter, which filters out fine particles and improves overall air quality.

So there's always a pleasant atmosphere inside the CL. Not only does this increase comfort levels, it helps the driver to concentrate too, meaning greater safety for all occupants.

Seats

The specially styled seats in the CL satisfy the most exacting standards as far as ergonomics, comfort and safety are concerned

Active multicontour seats (optional, standard from CL 500 4MATIC BlueEFFICIENCY). Massage and dynamic functions offer an exceptional degree of comfort on longer trips. A series of air chambers can be adjusted to suit individual

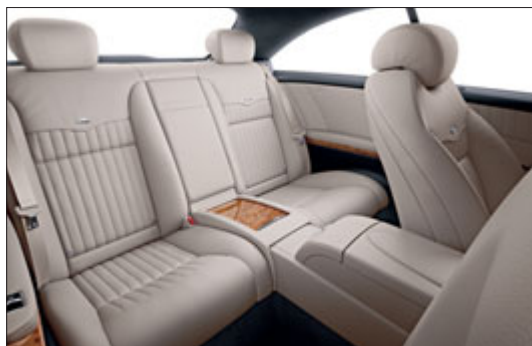

Comfortable individual seats in the rear

body shapes, while the seat's side bolsters adjust dynamically in line with the car's movements. The NECK-PRO luxury head restraints and 4-way lumbar support also make for supreme seating comfort.



The active multicontour front seats with massage and dynamic functions

Climatised front seats (optional, standard in CL 600, CL 63 AMG and CL 65 AMG). The ventilation and heating controls ensure a pleasant seat climate.

CL 500 BlueEFFICIENCY

Masterful in every respect – the CL 500 BlueEFFICIENCY is a perfect counterpart for highly successful drivers

The CL 500 BlueEFFICIENCY comes with a metallic paint finish and 5-spoke light-alloy wheels with 255/45 R 18 tyres as standard. It is further distinguished by the LED Light package, comprising bi-xenon headlamps, Intelligent Light System, Adaptive Highbeam Assist as well as LED daytime running lamps with chrome surrounds. The doorhold function also forms part of the standard specification, as does the EASY-ENTRY



The CL 500 BlueEFFICIENCY has a self-assured air about it

system with automatic steering wheel adjustment. The interior is given an exclusive flair by trim made from select woods in three different grain patterns and fine leather in five delicately coordinated colour combinations. The electrically adjustable heated front seats with 4-way lumbar support promise top-class comfort. Thanks to the COMAND control and display system, all of the main entertainment and communications



Multifunction steering wheel in nappa leather

functions are integrated into a single, user-friendly colour screen. Driving safety is heightened by standard-fit systems such as ATTENTION ASSIST, Active Body Control (ABC) including crosswind stabilisation and the Torque Vectoring Brakes cornering control. There is also PARKTRONIC including Parking Guidance to help with parking.

CL 500 4MATIC BlueEFFICIENCY

Keeping all four wheels firmly on the ground – the CL 500 4MATIC BlueEFFICIENCY

Drivers are able to enjoy exceptionally high levels of traction in all weathers in the CL 500 equipped with 4MATIC permanent all-wheel drive. This system splits the drive torque between the two axles in the ratio 45 : 55, thereby maximising vehicle grip and increasing handling stability in adverse road conditions. All with just a small average fuel penalty compared to the two-wheel-drive model. Plus, there is the electro-

nically controlled damping system AIRMATIC with all-round self-levelling for excellent ride comfort and handling safety.

Standard equipment for the CL 500 4MATIC BlueEFFICIENCY includes 15-spoke light-alloy wheels with 255/45 R 18 tyres, active multi-contour front seats with massage and dynamic functions plus PRE-SAFE® positioning function,

as well as an interior upholstered in sumptuous PASSION leather. Winter sports enthusiasts will be pleased to know a handy ski bag is also included as standard to protect the interior.



4MATIC, the all-wheel-drive system from Mercedes-Benz

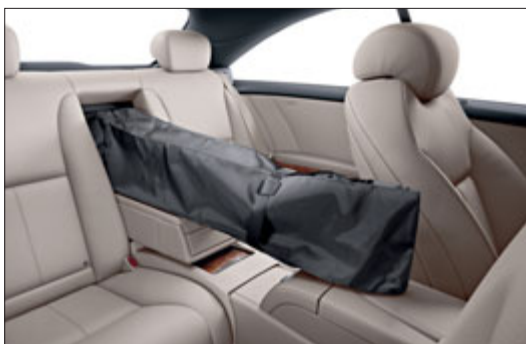

The ski bag protects the exclusive interior appointments



The 15-spoke light-alloy wheels

CL 600

Well thought-out details and a wealth of luxurious appointments in the CL 600 make for supremely relaxed motoring

The CL 600 rides on V12-design light-alloy wheels shod with 255/45 R 18 tyres at the front and 275/45 R 18 tyres at the rear. At the front is an imposing radiator grille with V12 styling and two twin louvres, while V12 emblems on the wings, a chrome-plated boot sill and the two sets of twin tailpipes with vertical dividers incorpo-



The V12 logo appears in the start screen when the engine of the CL 600 is fired

rated into the rear bumper further differentiate it from the CL 500 BlueEFFICIENCY.

The passenger compartment is awash with luxurious appointments thanks to the Interior package, featuring designo-style Exclusive PASSION leather upholstery perfectly complemented by



The chrome-plated boot sill and the tailpipes with vertical dividers incorporated into the rear bumper

wood trim in handpicked high-gloss brown poplar with V12 emblem. This same exquisite material can be found on the wood/leather steering wheel, while the V12 fluting on the upholstery and roof liner also helps to clearly set the tone. The classy look is completed by such fine touches as the velour floor mats with V12 emblem as well as the chromed V12-design door sill panels.

The CL 600 naturally comes with an extensive standard specification besides this, including KEYLESS-GO, ambient lighting, active multicon-tour and climatized front seats, COMAND APS, Harman Kardon® Logic 7® surround sound system, SPLITVIEW, as well as the reversing camera, an electric roller blind for the rear window and the Anti-Theft Protection package.



The front end of the CL 600 sporting a new radiator grille and standard LED daytime running lamps, as well as LED indicators and side lamps

CL 63 AMG

Bringing racetrack performance to the open road – the CL 63 AMG → www.mercedes-amg.com



The CL 63 AMG boasts all the essential qualities of an exceptional athlete – power, endurance and speed

This is a car that lives up to first impressions: the CL 63 AMG greets the driver with a new-look, muscular front apron incorporating AMG-specific LED daytime running lamps and a black cross strut, as well as powerfully moulded side skirts. The new AMG-styled radiator grille with its single chrome-edged louvre is just as eye-catching as the new body-coloured diffuser-look rear apron. The chrome twin tailpipes also feature a new design, as do the AMG triple-spoke light-alloy wheels with tyre size 255/40 R 19 at the front and 275/40 R 19 at the rear. To further emphasise the car's mighty looks, AMG twin-spoke forged wheels from the AMG Performance Studio can be fitted, with tyre dimensions of 255/35 R 20 at the front and 275/35 R 20 at the rear.

The cockpit clearly bears the stamp of AMG too: there is an AMG sports steering wheel with silver-coloured aluminium shift paddles as well as an AMG instrument cluster featuring a new AMG V8 BITURBO start screen and main menu with RACETIMER function. The menu displays information such as the selected gear and engine

oil temperature, while the RACETIMER can even clock lap times. The IWC-designed analogue clock goes perfectly with either the standard trim in high-gloss dark brown burr walnut or the optional AMG carbon-fibre trim. PASSION leather upholstery with a special AMG seat pattern puts the final touch to the CL 63 AMG's sporty air.



AMG sports seats upholstered in PASSION leather with an exclusive AMG seat pattern and natural leather in the side bolsters



AMG sports steering wheel with silver-coloured aluminium shift paddles

CL 63 AMG technology

Thrilling experiences at the wheel and maximum efficiency with the new AMG 5.5-litre V8 biturbo engine and the AMG SPEEDSHIFT MCT 7-speed sports transmission → www.mercedes-amg.com

AMG 5.5-litre V8 engine. The new AMG V8 biturbo in the CL 63 AMG excels not just with its sheer power but with its extraordinary efficiency too. It delivers up to 400 kW and 800 Nm of torque or, with the optional AMG Performance package, an even more impressive 420 kW and 900 Nm, yet it achieves a combined fuel consumption of just 10.5 l/100 km, setting new standards in its segment. This is all thanks to the unique combination of innovative high-tech systems such as direct petrol injection, twin turbochargers, braking energy recuperation and the Controlled Efficiency driving mode with start/stop function. And, just as you would expect from an AMG, it produces a powerful, resonant engine sound.



The new AMG 5.5-litre V8 biturbo with up to 420 kW and 900 Nm of torque

AMG SPEEDSHIFT MCT 7-speed sports transmission. Unites the best of both worlds, offering the sporty, direct and agile response of a manual transmission and the supreme comfort of an automatic. With the three driving modes Controlled Efficiency, Sport and Manual, drivers can decide how dynamically they want to change between the transmission's seven gears. Fast downshifting is a further strength of the new AMG SPEEDSHIFT MCT 7-speed sports transmission; via kickdown you can change straight from seventh to fourth gear, for example, allowing the AMG V8 biturbo engine's power to be exploited to maximum effect.

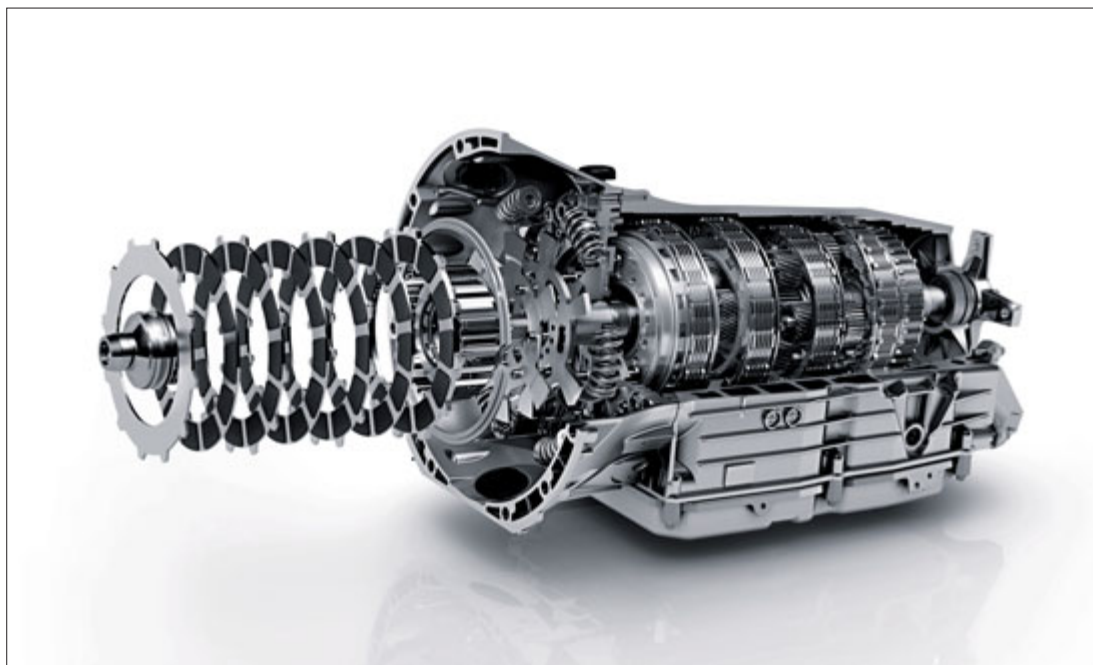

Fast and easy: changing gear with the AMG SPEEDSHIFT MCT 7-speed sports transmission

CL 65 AMG

Prestige and effortless superiority in perfect harmony – the CL 65 AMG → www.mercedes-amg.com



The CL 65 AMG is a genuine athlete, shrouded in luxury and elegance

Radiating the same aura of sporty elegance as the CL 63 AMG, this model's 5-twin-spoke forged wheels with tyres size 255/35 R 20 at the front and 275/35 R 20 at the rear, the two V12-design chromed twin tailpipes, as well as the V12 BITURBO lettering on the front wings provide telltale signs of its true power and dynamism. Both the CL 63 AMG and CL 65 AMG can be further customised with options such as the AMG Exterior Carbon-Fibre package: here, the front apron's cross strut, exterior mirror housings and the insert in the rear apron are all made from carbon fibre.

The CL 65 AMG is just as exclusive on the inside. The seat backrests' specially moulded contours allow drivers to sit perfectly comfortably even when powering through corners. The Exclusive PASSION leather in AMG V12 design covering

the AMG sports seats and door centre panels forms part of the Exclusive PASSION Leather package's appointments and adds to the unique sense of sportiness.

The sports pedals made from rubber-studded brushed stainless steel provide another touch of



Exclusive PASSION Leather package featuring AMG sports seats with an exclusive AMG upholstery pattern

sporty elegance. Behind the new AMG sports steering wheel with silver-coloured aluminium shift paddles, the instrument cluster catches the eye with its special AMG V12 BITURBO start screen, 360 km/h scale and AMG main menu.



Chromed twin tailpipes in V12 design

Standard equipment | Selection



Multifunction steering wheel in nappa leather



COMAND colour display



Memory function for front seats



Telephone keypad



LED daytime running lamps



LED tail lights

Optional extras | Selection



Active Blind Spot Assist



Ambient lighting in three tones



KEYLESS-GO



Harman Kardon® Logic 7® surround sound system



Night View Assist Plus



SPLITVIEW

AMG Sports package

Dynamic styling and a prestigious brand of sportiness

The AMG Sports package injects the CL with even more dynamism. It begins on the outside with a powerfully moulded AMG front apron and side skirts, continuing all the way back to the distinctive AMG rear apron.



Dynamism with just the right dose of prestige

The stunning look is completed by AMG 5-spoke light-alloy wheels with a high-shine finish. Another distinguishing feature vis-à-vis the standard model is the painted front brake callipers with “Mercedes-Benz” lettering. There are even



The distinctive rear apron – part of the AMG Sports package

more differences inside, including wooden trim in high-gloss black ash. Then there is the wood/leather steering wheel and, finally, the rubber-studded sports pedals made from brushed stainless steel and matching AMG floor mats in black velour. The AMG Sports package is available for the CL 500 BlueEFFICIENCY, CL 500 4MATIC BlueEFFICIENCY and CL 600 models.



The AMG Sports package lends the CL a sporty, dynamic aura

designo

A wealth of high-grade appointments and special details make designo an alluring proposition → www.mercedes-benz.com/designo

The handcrafted designo range offers almost unlimited scope for customisation with its wide choice of colours, select trim options and exquisite materials. There are ten variants on offer

just for the exterior paintwork of your CL, including three exclusive matt paint finishes (magno).

Moving inside, there is a choice of designo aniline leather or designo natural leather in a variety of colours. Plus, customers can select from a wide range of stylistically matched wood or stone trim elements, such as wafer-thin polished stone or high-gloss piano lacquer, applied in up to ten coats.

The characteristic seat pattern with ten-rib vertical fluting and the designo badge in the seat backrests also help to lend the interior an extra-special feel, as do the wood/leather steering wheel and roof liner in fabric, Alcantara® or black leather.



Exterior paintwork in designo magno cashmere white (049)

designo is sure to give added impact to the exclusive nature of the CL, whether it is with harmonious colour combinations or boldly contrasting highlights.

Further designo features and information can be found on the website, where you also have the opportunity to visualise your dream car.



designo selection with designo logo in 18-carat gold



Door panel in designo light brown Exclusive aniline leather (X35)



Upholstery in designo light brown Exclusive aniline leather (X35) with trim in black designo piano lacquer (W69)

Upholstery and trim





The black colour scheme offers a choice between leather seat upholstery (standard) or, depending on the model, either the PASSION leather or Exclusive PASSION Leather package upholstery. The interior (dashboard, steering wheel, centre console, side panels and carpet) is finished in black throughout. In conjunction with the Exclusive PASSION Leather package, the dashboard, door linings, seatback panels, ruffled pockets and parcel shelf are additionally trimmed in leather, while the roof as well as the A- and C-pillars are lined in Alcantara®.

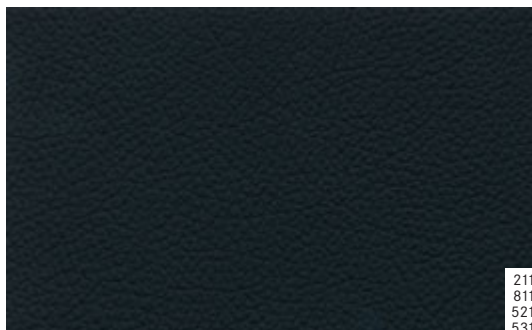

211
811
521
531



● H14



● 731



● 736



○ H18

BLACK/BLACK

- 211 Leather
- 811 PASSION leather¹
- 521 Exclusive PASSION Leather package¹
- 531 Exclusive PASSION Leather package²

TRIM

- H14 High-gloss light brown burr walnut wood
- 731 High-gloss dark brown burr walnut wood³
- 736 High-gloss black ash wood
- H18 High-gloss brown poplar wood⁴

¹ Optional ² Standard for V12 ³ Standard for V8, optional for V12 ⁴ Only for V12

● Recommended ○ Possible △ Not recommended



The cashmere beige/savanna beige colour scheme includes leather upholstery, lower dashboard section, centre console and door interiors in cashmere beige. The upper section of the dashboard, steering wheel, door edges and carpet are finished in savanna beige. The same colour combination is furthermore available for either the PASSION leather or Exclusive PASSION Leather package variants, depending on the particular model. The latter option includes a PASSION leather trim for the dashboard, door linings, seatback panels, ruffled pockets and parcel shelf. The roof and the A- and C-pillars are again lined in Alcantara® to add an extra touch of class.



214
814
524
534



● H14



● 731



○ Q 736



● H18

CASHMERE BEIGE/SAVANNA BEIGE

- 214 Leather
- 814 PASSION leather¹
- 524 Exclusive PASSION Leather package¹
- 534 Exclusive PASSION Leather package²

TRIM

- H14 High-gloss light brown burr walnut wood
- 731 High-gloss dark brown burr walnut wood³
- 736 High-gloss black ash wood
- H18 High-gloss brown poplar wood⁴

¹ Optional ² Standard for V12 ³ Standard for V8, optional for V12 ⁴ Only for V12

● Recommended ○ Possible △ Not recommended



The alpaca grey/basalt grey colour scheme includes leather upholstery, lower dashboard section, centre console, door interiors and carpet in alpaca grey. The upper section of the dashboard, steering wheel and door edges are finished in basalt grey. The PASSION leather or Exclusive PASSION Leather package appointments are available in the same colour combination, either as standard or optionally depending on the model. The latter option includes a PASSION leather trim for the dashboard, door linings, seatback panels, ruffled pockets and parcel shelf. The roof as well as the A- and C-pillars are lined in Alcantara® to add an extra touch of class.

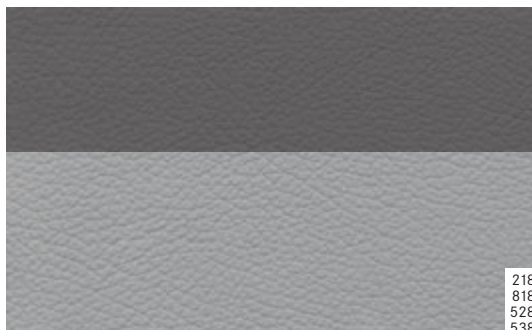

218
818
528
538



● H14



● 731



● 736



△ H18

ALPACA GREY/BASALT GREY

- 218 Leather
- 818 PASSION leather¹
- 528 Exclusive PASSION Leather package¹
- 538 Exclusive PASSION Leather package²

TRIM

- H14 High-gloss light brown burr walnut wood
- 731 High-gloss dark brown burr walnut wood³
- 736 High-gloss black ash wood
- H18 High-gloss brown poplar wood⁴

¹ Optional ² Standard for V12 ³ Standard for V8, optional for V12 ⁴ Only for V12

● Recommended ○ Possible △ Not recommended



The Sahara beige/black colour scheme includes leather upholstery, lower dashboard section, lower centre console and door interiors in Sahara beige. The upper section of the dashboard, steering wheel, upper centre console, door edges and carpet are finished in black. The same colour combination is also available for either the PASSION leather or Exclusive PASSION Leather package variants, depending on the particular model. The latter option includes a PASSION leather trim for the dashboard, door linings, seatback panels, ruffled pockets and parcel shelf. The black Alcantara® lining for the roof and the A- and C-pillars adds touches of contrasting colour.

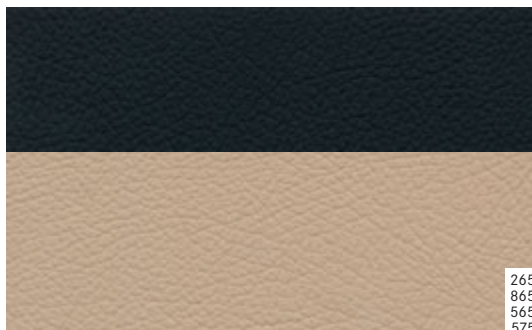

SAHARA BEIGE/BLACK

- 265 Leather
- 865 PASSION leather¹
- 565 Exclusive PASSION Leather package¹
- 575 Exclusive PASSION Leather package²

TRIM

- H14 High-gloss light brown burr walnut wood
- 731 High-gloss dark brown burr walnut wood³
- 736 High-gloss black ash wood
- H18 High-gloss brown poplar wood⁴

¹ Optional, not available for CL 63 AMG ² Only for CL 600

³ Standard for V8, optional for V12 ⁴ Only for V12

● Recommended ○ Possible △ Not recommended



The aubergine/black colour scheme includes leather upholstery, lower dashboard section, lower centre console and door interiors in aubergine. The upper section of the dashboard, steering wheel, door edges and carpet are finished in black. The PASSION leather or Exclusive PASSION Leather package appointments that are available either as standard or optionally, depending on the model, come in the same colour combination. The latter option includes a PASSION leather trim for the dashboard, door linings, seatback panels, ruffled pockets and parcel shelf. The black Alcantara® lining for the roof and the A- and C-pillars provides the perfect finishing touch.

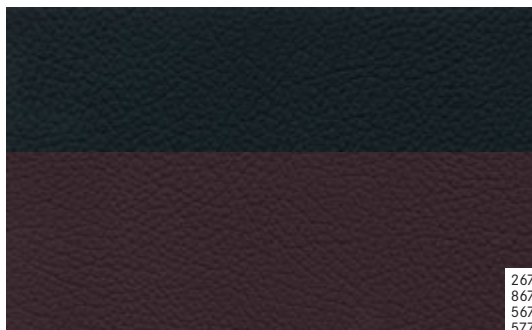

267
867
567
577



● H14



● 731



● 736



○ H18

AUBERGINE/BLACK

- 267 Leather
- 867 PASSION leather¹
- 567 Exclusive PASSION Leather package¹
- 577 Exclusive PASSION Leather package²

TRIM

- H14 High-gloss light brown burr walnut wood
- 731 High-gloss dark brown burr walnut wood³
- 736 High-gloss black ash wood
- H18 High-gloss brown poplar wood⁴

¹ Optional, not available for CL 63 AMG ² Only for CL 600

³ Standard for V8, optional for V12 ⁴ Only for V12

● Recommended ○ Possible △ Not recommended

Wheels



V12 5-spoke light-alloy wheels with 255/45 R 18 front and 275/45 R 18 rear tyres (standard for CL 600)



7-twin-spoke light-alloy wheels, high-shine finish, with 255/45 R 18 front and 275/45 R 18 rear tyres, 255/45 R 18 tyres all round on 4MATIC models (optional)



Multi-spoke light-alloy wheels with 255/40 R 19 front and 275/40 R 19 rear tyres, 255/40 R 19 tyres all round on 4MATIC models (optional)



5-spoke light-alloy wheels with 255/45 R 18 tyres all round (standard for CL 500 BlueEFFICIENCY)



15-spoke light-alloy wheels with 255/45 R 18 front and 275/45 R 18 rear tyres, 255/45 R 18 tyres all round on 4MATIC models (optional, standard for CL 500 4MATIC BlueEFFICIENCY)



10-spoke light-alloy wheels with 255/45 R 18 front and 275/45 R 18 rear tyres, 255/45 R 18 tyres all round on 4MATIC models (optional)



5-spoke light-alloy wheels with 255/40 R 19 front and 275/40 R 19 rear tyres, 255/40 R 19 tyres all round on 4MATIC models (optional)



AMG 5-spoke light-alloy wheels with 255/40 R 19 front and 275/40 R 19 rear tyres, 255/40 R 19 tyres all round on 4MATIC models, high-shine finish (AMG Sports package)



AMG 5-twin-spoke light-alloy wheels with 255/35 R 20 front and 275/35 R 20 rear tyres, 255/35 R 20 tyres all round on 4MATIC models (optional)



AMG twin-spoke forged wheels with 255/35 R 20 front and 275/35 R 20 rear tyres, black, polished finish (optional for CL 63 AMG and CL 65 AMG)



incenio "Nuklida" 5-Y-spoke light-alloy wheels¹ for 255/40 R 19 front and 275/40 R 19 rear tyres, 255/40 R 19 tyres all round on 4MATIC models, titanium silver, high-shine finish (accessory)



AMG triple-spoke light-alloy wheels with 255/40 R 19 front and 275/40 R 19 rear tyres (standard for CL 63 AMG)



AMG twin-spoke forged wheels with 255/35 R 20 front and 275/35 R 20 rear tyres, titanium grey, polished finish (standard for CL 65 AMG, optional for CL 63 AMG)



"Alaraph" 10-spoke light-alloy wheels with 255/35 R 20 front and 275/35 R 20 rear tyres, 255/35 R 20 tyres all round on 4MATIC models, sterling silver (factory-fitted accessory)



incenio "Kiyali" 5-spoke light-alloy wheels¹ for 255/35 R 20 front and 275/35 R 20 rear tyres, titanium silver (accessory)

¹ incenio light-alloy wheels are supplied without tyres

Genuine accessories

A Mercedes-Benz is more than just a car. It can be a travel companion, an office, a living space. And this diversity is reflected in the Mercedes-Benz range of accessories.



incenio "Maedis" designer wheel

The Mercedes-Benz genuine accessories range for the CL features a host of ingenious and practical ideas. Take, for example, the dust cover made from elastic synthetic fibre, which is designed to protect your CL from dirt, dust and scratching. Or the sturdy chromed metal coat hangers, which can be simply attached to the back of the front head restraints for keeping items of clothing free of creases during the journey. The shallow boot tub is extremely handy for carrying even groceries and liquids. The tub's shape with its slightly raised rim is a perfect fit for the floor of the boot, while its ribbed structure stops the cargo from sliding around. And for even greater visual impact,



Boot tub



Coat hanger

there are also the incenio “Maedis”, “Hymara” and “Nuklida” light-alloy wheels.

The genuine accessories range offers you a wide selection of top-quality items to choose from. Please see our accessories brochure for further details, or contact your Mercedes-Benz dealer who will be happy to advise you.



Dust cover

Services

Mercedes-Benz Museum. More than 120 years of automotive history in one place – this is what awaits you at the Mercedes-Benz Museum in Stuttgart. Experience the unique excitement, and embark upon a thrilling journey through time. Housed inside an architecturally impressive building, over 1500 exhibits on nine levels give you an insight into the unique tradition and powers of innovation of the Mercedes-Benz brand. You can see the world’s first two automobiles – the Benz Patent-Motorwagen and the Daimler motorised carriage – both from the year 1886. Two interlinked tours take you from the beginnings of the motor car, past a series of unforgettable classics, through more than 100 years of motor racing history and, finally, on to a glimpse of what the future holds – in an area covering a total of 16,500 square metres. Enjoy the unique brand experience. We look forward to your visit. Further details can be found at www.mercedes-benz-classic.com/museum

MercedesCard. This card is your ticket to the Mercedes-Benz experience: four times a year, we will send you exciting details of a selected range of events and services, which we have put together exclusively for you. Then there is the Mercedes Magazine with its fascinating reports and articles. But the MercedesCard also has many other uses: as a VISA credit card, it is an internationally accepted means of payment. Plus, it offers further benefits to provide you with peace of mind, such as insurance services. You can also gain free entry to the Mercedes-Benz Museum simply by showing your VISA MercedesCard. Further details can be found at www.mercedes-benz.de/mercedescard¹

Mercedes-Benz Bank. If you have already chosen your dream car and want to remain financially flexible, you should make us your next port of call, whether it be for leasing, finance, insurance or service packages. By way of example, our “Private Leasing plus” scheme is a complete package comprising leasing, third-party insurance and fully-comprehensive insurance. “Business Leasing plus” for business customers works in much the same way. Meanwhile, our “Plus3” financing combines the low repayment rates of a financing scheme with the flexibility of leasing. You then have three options at the end of the contract: you can keep the car, sell it or return it to us for a guaranteed price and switch to a new model. We can also offer a range of investment products such as fixed-interest products, savings plans, investment funds or depository receipts. For further information, please call us on +49 681 96 59 50 00 or visit us at www.mercedes-benz-bank.de

Mercedes-Benz mobility. Your new car comes with the assurance of carefree driving, but if you should ever need help Mercedes-Benz Service24h is there for you. Just call the freephone service hotline on 00800 1 777 7777². The newly integrated telematics service Mercedes-Benz Contact³ is even more customer-friendly: a touch of a button is all it takes to contact the Mercedes-Benz customer centre. If you wish, all the relevant vehicle and position-related data can be transmitted at the same time, ensuring the shortest possible reaction time and rapid on-the-spot assistance. Also standard with your new car at no extra charge is the Mercedes-Benz Mobilo⁴ mobility package. Whether you have lost your key, had a breakdown which cannot be repaired immediately or your vehicle has been damaged in an accident or vandalised, Mobilo ensures that you still reach your destination – anywhere in Europe. Whatever your problem, one thing is certain: you will soon be able to resume your journey.

Test drive. The unique feeling of driving a Mercedes cannot be put into words. Which is why we'd like to invite you to take a test drive. Just visit www.mercedes-benz.com to locate your nearest Mercedes-Benz dealer.

Service packages. Our vehicle-specific service packages can be individually tailored to suit your requirements and range from the Mercedes-Benz warranty package for extended protection against unforeseeable repair costs to the full service package for your new car. You are therefore assured of always receiving the highest possible standard of service for your Mercedes, all for a convenient fixed price. Please ask your Mercedes-Benz dealer for further details.

Interactive Owner's Manual. You can take a closer look at your desired model online by taking our interactive tour. Information clips provide you with an ideal way of getting acquainted with your dream car. You can view key functions in detail, gain an insight into the car's inner workings or learn about the benefits of each model. For further details, visit www.mercedes-benz.de/owners-manual

Mobile internet. Now you can access the entire world of Mercedes-Benz from your mobile phone. As well as an overview of all the passenger car models, there are insights into the entire brand world along with a wealth of entertainment offers and direct links to a range of services at www.mercedes.mobi

Dimensions

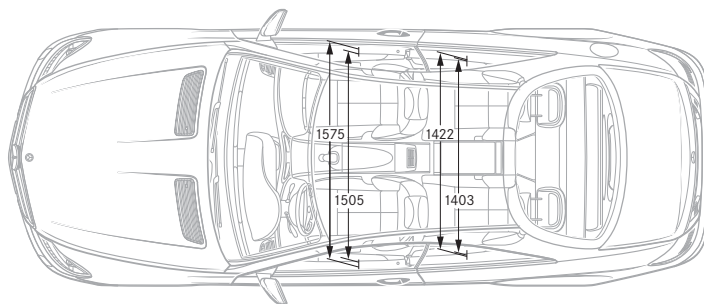
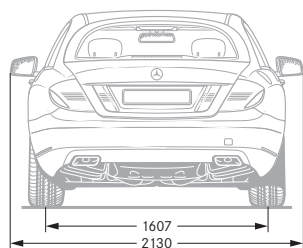
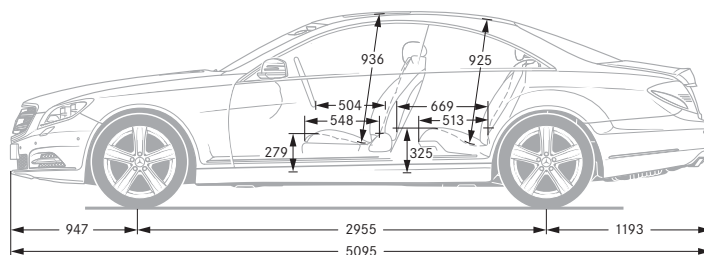
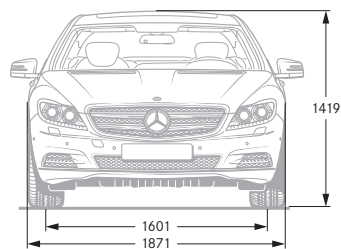

Paintwork

NON-METALLIC PAINTS (standard)

040 black

METALLIC PAINTS (standard)

183 magnetite black

197 obsidian black

300 periclase green

359 tanzanite blue

368 flint grey

474 peridot brown

544 carneol red

775 iridium silver

792 palladium silver

SPECIAL METALLIC PAINTS (optional)

228 cornetite blue

799 diamond white BRIGHT

Technical data

PETROL ENGINES	CL 500 BlueEFFICIENCY	CL 500 4MATIC BlueEFFICIENCY
No. of cylinders/arrangement	8/V	8/V
Total displacement (cc)	4663	4663
Rated output ¹ (kW at rpm)	320/5250	320/5250
Rated torque ¹ (Nm at rpm)	700/1800–3500	700/1800–3500
Acceleration from 0–100 km/h (s)	4.9	4.9
Top speed, approx. (km/h)	250 ²	250 ²
Fuel consumption ³ (l/100 km)		
urban	13.5–13.9	13.9–14.0
extra-urban	7.2–7.6	7.6–7.9
combined	9.5–9.9	9.9–10.1
CO ₂ emissions ³ (g/km) combined	224–232	237–242
Emissions standard	Euro 5	Euro 5
Max. boot capacity (l)	490	490
Kerb weight ⁴ (kg)	2070	2120
Permissible gross vehicle weight (kg)	2585	2555

¹ Figures according to Directive 80/1269/EEC in the currently applicable version ² Electronically governed ³ The figures shown were obtained in accordance with the prescribed measuring process (Directive 80/1268/EEC in the currently applicable version). The figures are not based on an individual model and do not constitute part of the product offer; they are provided solely for purposes of comparison between different vehicle models

CL 600	CL 63 AMG	CL 65 AMG
12/V	8/V	12/V
5513	5461	5980
380/5000	400/5500	463/4800
830/1800-3500	800/2000-4500	1000/2300-4300
4.6	4.5 (4.4 ⁵)	4.4
250 ²	250 ² (300 ⁵)	250 ²
21.1-21.2	14.4	21.8
9.6-9.9	8.2	9.9
13.8-14.0	10.5	14.3
322-328	244	334
Euro 5	Euro 5	Euro 5
490	490	490
2185	2135	2245
2620	2585	2645

⁴ Figures according to Directive 92/21/EC, version 95/48/EC (kerb weight with fuel tank 90% full, driver, 68 kg, and luggage, 7 kg) for standard-specification vehicles. Optional extras and accessories will generally increase this figure and reduce the payload capacity accordingly ⁵ In conjunction with AMG Performance package, Code P30 Further technical data can be found at www.mercedes-benz.com

NON-METALLIC PAINT



040

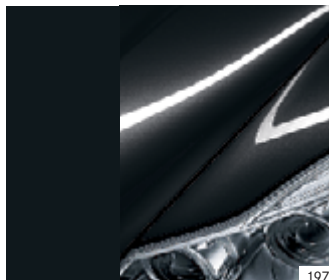

197

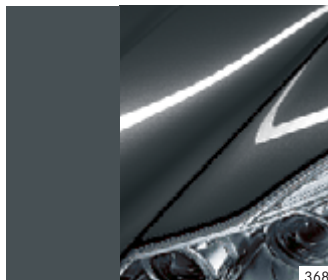

368



775

SPECIAL METALLIC PAINTS



228



300

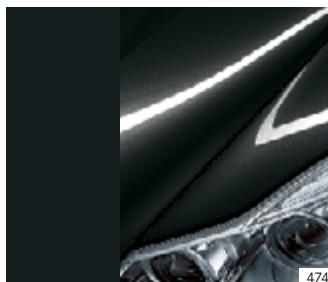

474



792



799

METALLIC PAINTS



183



359



544

Take-back of end-of-life vehicles. At the end of its long life, you can return your CL-Class to us for environment-friendly disposal in accordance with the EC End-Of-Life Vehicle Directive¹. But that day lies a long way off.

¹ Applies in accordance with national regulations to vehicles up to 3.5 tonnes gross weight. Mercedes-Benz passenger cars have met the statutory regulations governing the suitability of their design for reuse and recycling for a number of years now. A network of vehicle take-back depots and dismantlers has been established which will process your vehicle in an environment-friendly manner. The ways in which both vehicles and parts can be recovered are subject to ongoing development and improvement. Consequently, the CL-Class will be able to comply with any future increases in the recycling quota within the stipulated time limits. For further information please call 00800 1 777 7777.

Please note: changes may have been made to the product since this brochure went to press (15.06.2010). The manufacturer reserves the right to make changes to the design, form, colour and specification during the delivery period, provided these changes, while taking into account the interests of the vendor, can be deemed reasonable with respect to the purchaser. Where the vendor or the manufacturer uses symbols or numbers to describe an order or the subject of an order, no rights may be derived solely from these. The illustrations may show accessories and items of optional equipment which are not part of standard specification. Colours may differ slightly from those shown, owing to the limitations of the printing process. This brochure provides a general indication of the range of models, features, optional extras, colours and/or services available in various countries. Some of the models, features, optional extras, colours and/or services may not be available in your country, or may only be available in a different specification. Additionally some models, features, optional extras, colours and/or services may only be available in combination with others. For current and more specific information in relation to the range of models, features, optional extras, colours and/or services available in your country, and their pricing, you should contact your nearest authorised Mercedes-Benz Passenger Car Dealer.

www.mercedes-benz.com