



This Brochure is prepared by Daimler AG and it predominantly reflects the capabilities and performance of vehicles sold in Europe. Some characteristics, capabilities, performance features and optional extras (e.g. towing systems) may not be available or may not apply in Australia or under Australian conditions. The information in this Brochure is therefore indicative, illustrative and provided only for guidance and should not be relied on. To obtain current and accurate information on a vehicle and any options applicable to Australia, contact your local authorised Mercedes-Benz dealer.

Mercedes-Benz

The G-Class



Mercedes-Benz

“Our philosophy is very simple.
We give our best for people who expect the best.”

Dr Dieter Zetsche

Contents

The G-Class	10	My G-Class	42
Variants	12	Equipment & appointments	44
Refinement	14	Standard equipment	46
Petrol engines	14	Light-alloy wheels	52
BlueTEC	16	Optional extras	54
Transmissions	18	Colours and materials	62
Frame and chassis	20	Leather	64
On-road/off-road systems	22	Upholstery	66
Comfort	26	Combination options	73
Cockpit	26	Interior	74
Interior	28	Paintwork	77
Safety	34	Technical details	68
AMG	38	Dimensions	68
G 55 AMG	38	Technical data	79
AMG equipment	40	Services	70

Your destination: the horizon

The G-Class

Dynamism. Safety. Comfort. These are the classic attributes that transform a car into a Mercedes-Benz. And the G-Class – our classic off-roader – is no exception. The G-Class offers a unique take on these hallmark Mercedes-Benz attributes, even in the world's most remote locations where few vehicles make the grade.

The G-Class began its incredible journey back in 1979. Countless technical improvements and modernisation measures have been introduced over the years. Yet its unique character remains firmly intact. On the following pages, we bring you the next stage of this journey. Follow the further-refined G-Class as it heads for new horizons. And discover how one of the classics in automotive history is shining in a new light.





The G-Class: heading for new horizons













The G-Class



One legend. Several incarnations

All good things come in threes: the G-Class variants

The character of the G-Class has barely changed over the years. And why should it? After all, its distinctive form is a true design classic. Robust. Functional. Timeless.

Like every legend, the classic G-Class Off-roader gives customers a choice of versions. From the prestigious long-wheelbase Station Wagon and the short-wheelbase Station Wagon to the Cabriolet, the latter being the only one of its kind world-wide in this vehicle category. In addition to these different body variants, an AMG version of the long-wheelbase Station Wagon is also available. In terms of both looks and performance, this AMG model is quite simply in a class of its own (see AMG section starting on page 38). As is the case with so many legends, the different versions all have one core aspect in common: a licence to thrill.





On-road performance you just know will translate into off-road capability

Masters of every situation: the G-Class petrol engines

When you settle into your seat in a G-Class, you notice the difference immediately. The elevated seat position and the outstanding all-round visibility provide a clear indication of what is in store: a ride on board the G-Class is something very special indeed.

When you then start the engine of the G 500 you cannot fail to notice that under the bonnet there is something exceptional: the powerful 5.5-litre V8 engine, perfectly in tune with the manifold requirements of this versatile vehicle. With electronic petrol injection and four valves per cylinder, it ensures effortless power delivery at all times. And with 285 kW it can tackle the roughest terrain with the same poise and elegance it displays when breezing along in the fast lane – a characteristic that it quite clearly shares with the second petrol powerplant available for the

G-Class: the AMG V8 supercharged engine. Further details about this can be found starting on page 38.

G 500

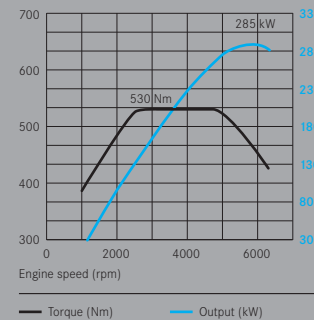

G 500. The G 500 achieves its peak torque of 530 Nm across a broad engine speed range from 2800 rpm to 4800 rpm



Ready equipped for the next climate summit

BlueTEC - the clean diesel

The further enhanced BlueTEC technology in the new G 350 BlueTEC developing 155 kW ensures exceptionally low emissions. BlueTEC catalytic converter technology allows the cleaning and aftertreatment of exhaust gases using the AdBlue® urea solution, making this compression-ignition engine an extremely clean diesel drive system. What's more, AdBlue® can now be poured into the tank



Simple and practical. Top up the AdBlue® in the G 350 BlueTEC just as you would the fuel

from outside just as easily as fuel, meaning that topping up is never a problem – even when driving off-road.

Exemplary emission figures, low fuel consumption, effortlessly superior performance and a high torque of 540 Nm – the G 350 BlueTEC sets the lead for others to follow.

G 350 BlueTEC

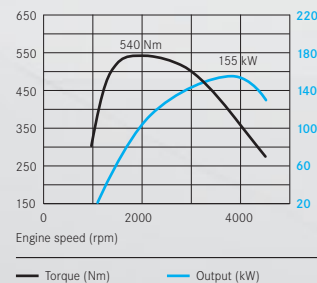

G 350 BlueTEC. The 3-litre V6 diesel engine achieves its powerful torque of 540 Nm over an engine speed range of 1600 to 2400 rpm

The more fluid the movement, the better the performance

The G-Class automatic transmissions

Sports stars hone their movements to perfection over a period of years, their theory being that smooth, fluid movements make for outstanding performance.

Inspired by this, the Mercedes-Benz engineers have developed an extremely fluid sequence of movements for the standard-fit 7G-TRONIC automatic transmission in the G 350 BlueTEC and G 500. The gear changes are barely perceptible – even when a gear is skipped, as is necessary on occasions. So you are always in the right gear, leaving you to enjoy the superlative driving dynamics and quiet ride.

The G 55 AMG features the specially tuned 5-speed automatic transmission which transfers the immense power and high torque of the AMG engine to the wheels with consummate ease.



Selector lever. Smooth shifts every time: the wood/leather selector lever with Mercedes-Benz badge

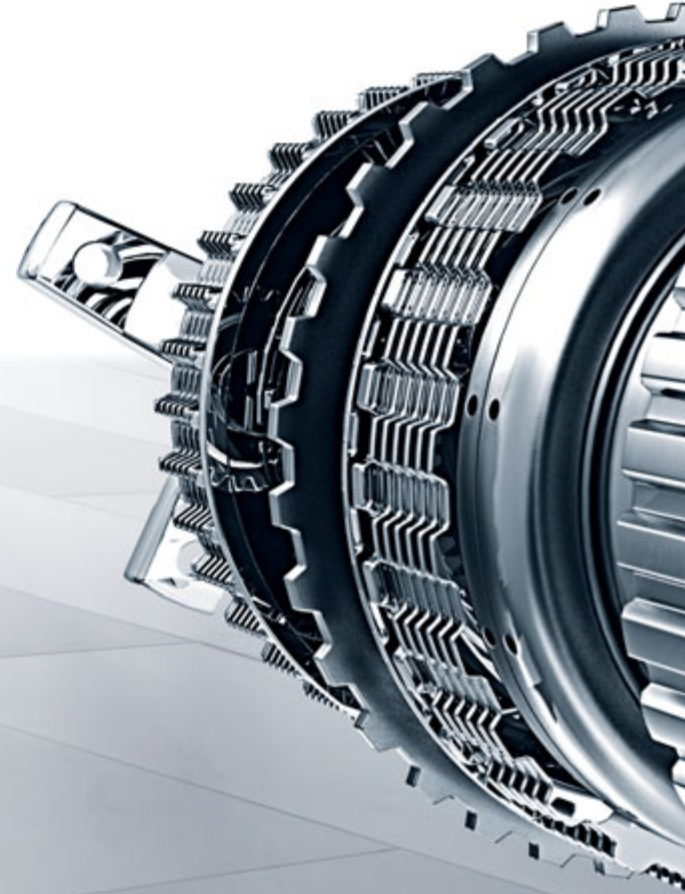

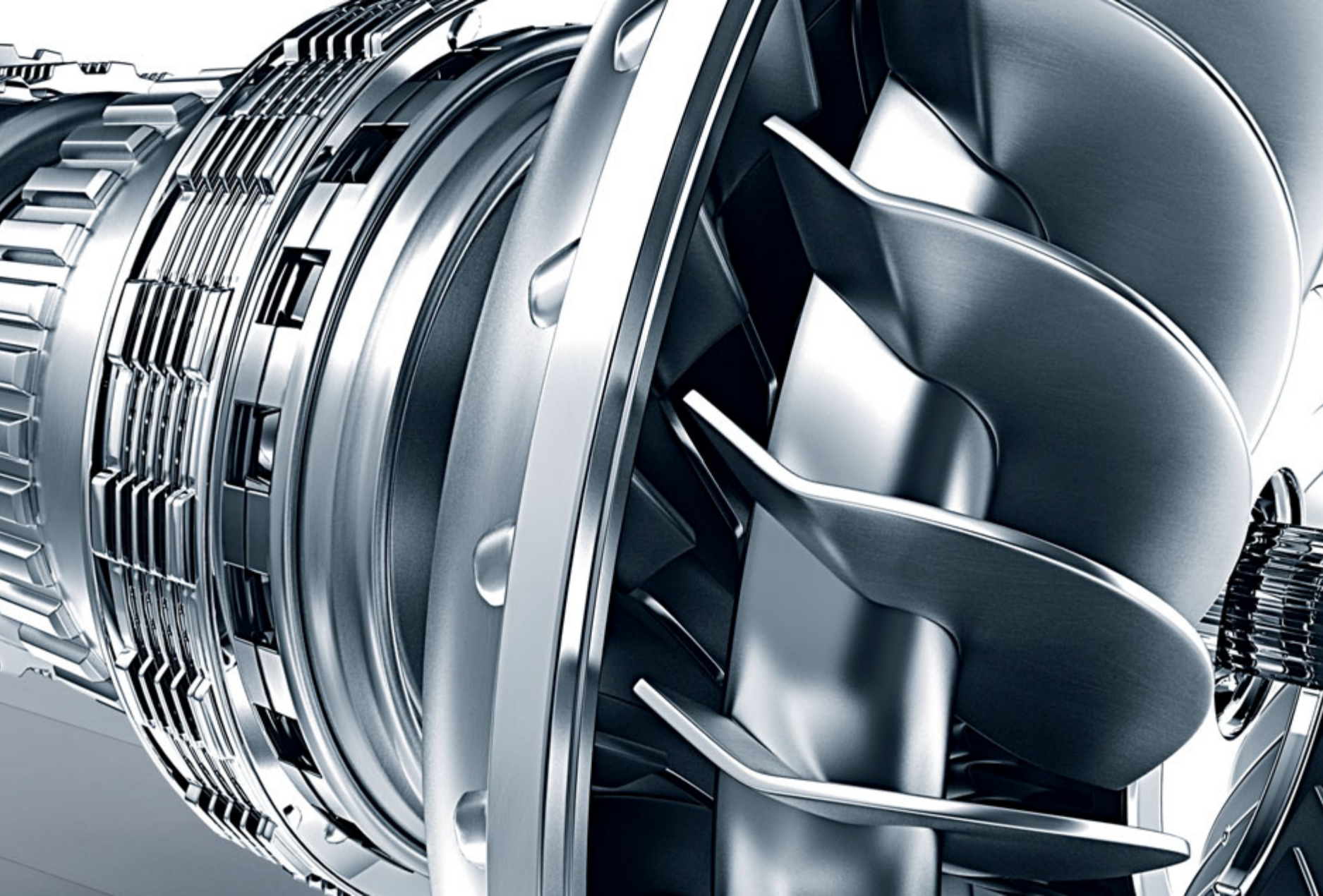

Tested to overcome any challenge

Frame and chassis configured for maximum performance

When building a G-Class, we leave nothing to chance. After all, longevity and value retention are key quality features that are a source of great pride to us.

Up to 4-mm thick in places, the G-Class frame is held together by more than 6400 weld spots. As well as that, it is surface-treated and waxed. The vehicle underfloor, meanwhile, has an additional plastic coating. And all attachments undergo thorough treatment in an electro dip-priming process before having several coats of paint applied. This level of protection leaves hardly any of the G-Class's surfaces open to attack by water, snow, road salt or even desert sand.

The real tests for the G-Class await off-road. And it prepares for these on our special off-roader test routes. This is where a G-Class has to pass its first driving test before being allowed to take the advanced test on the street.

On demanding terrain, two precisely located rigid axles with high torsional flexing and long suspension travel ensure the necessary ground clearance and outstanding traction, meaning that the permanent all-wheel-drive system can also exert its full influence.



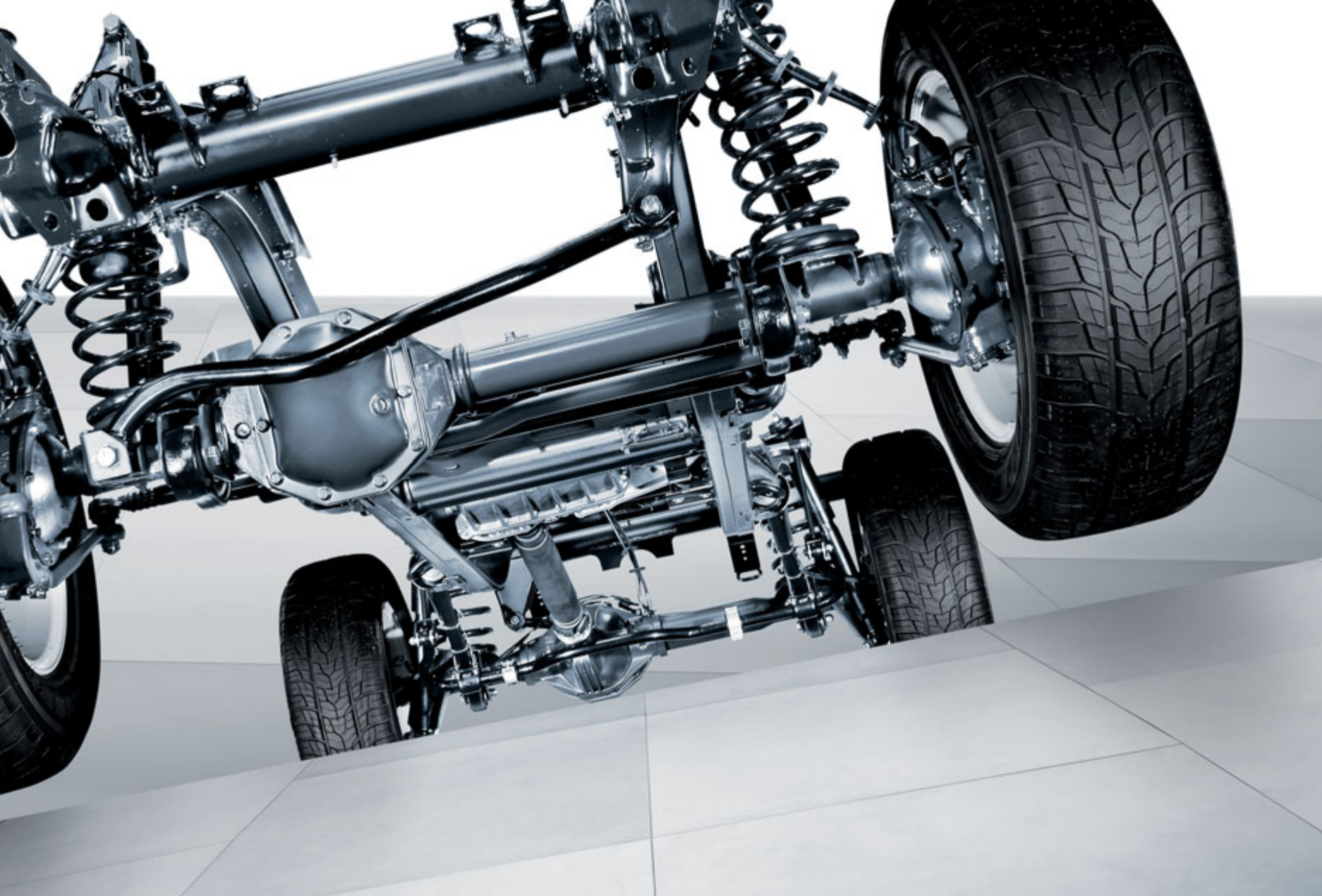

Power meets intelligence

Low-range ratio and traction system in the G-Class

Brute force alone does not make for smooth progress in difficult conditions. For this you need immense power with intelligent control. Driver aside, it is the electronically controlled traction system 4ETS that assumes this task in the G-Class, sending precisely the right amount of engine power to the wheels that currently offer the best traction, making it much easier to maintain control on snow or ice-covered surfaces.

The driver receives additional assistance courtesy of the transfer case's off-road ratio – part of the standard specification. One press of the low-range switch is all it takes to activate this feature. At low speed and with maximum traction, the G-Class overcomes obstacles with ease. It climbs, clambers and scrambles but, above all, it demonstrates just what it takes to be a truly great off-roader.

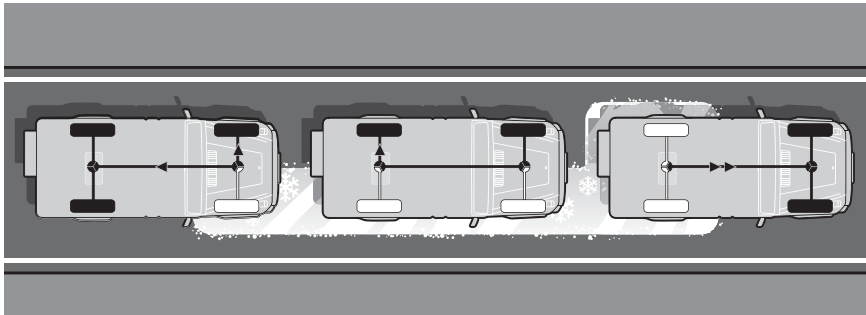

Greater driving stability thanks to 4ETS. If up to three wheels have poor grip, they are braked by 4ETS. The tractive power is then directed to the wheels offering better grip





Go over the next patch of scree. Then turn left into the river bed

Fully lockable differential locks for full-on off-road driving

Teamwork simply makes it easier to achieve great things. This is why everything works together in the G-Class. For example, the permanent all-wheel drive, the electronic traction system 4ETS, the synchromesh transfer case and the three fully lockable differential locks. This teamwork is one of the outstanding features of the G-Class. It is what makes it a true off-roader. No other vehicle comes close to offering such a unique combination of attributes.

Fitted as standard, the three differential locks can be activated individually and in a logically specified sequence. So you can be sure that the G-Class adapts perfectly to its surroundings. If a wheel loses traction, the power is redirected to the wheels offering the best grip. Even if only one wheel is providing grip, your G-Class will still make good headway – an impressive achievement. And just perfect when driving off-road.







One star at the front. Five stars inside

Neat, comfortable and innovative: the interior

A vehicle displaying the Mercedes star is a sure-fire bet when it comes to outstanding quality and workmanship. Nowhere is this more impressively apparent than in the interior of the G-Class.

The generous feeling of spaciousness imparts a sense of freedom. And that's before the G-Class has even started moving. What's more, the hallmark elevated seat position ensures excellent all-round visibility at all times, while the cockpit is designed with ease of operation firmly in mind.

You experience the comfort and convenience of a G-Class the second you open the doors and again when you close them. Attention to detail takes pride of place. As you will see when you touch the fine-leather-trimmed steering wheel which, of course, swings upwards once you have parked, to make getting out even easier. A service that merits five stars all of its own.

On the following pages you can familiarise yourself with the G-Class equipment and appointments. Plus we will show you how to create your own individual G-Class (page 54 onwards).



All under control. The multifunction steering wheel is available as standard in leather (G 350 BlueTEC) or wood/leather (G 500 and G 55 AMG)





The drive just can't last long enough

First-class travel: seating comfort in the G-Class

After a long drive in the G-Class, it's hardly surprising that many want to stay seated a while longer. That's because the new seats leave practically nothing to be desired. The front seats adjust electrically, allowing you to select your preferred seat position. And, as you would expect from a vehicle such as the G-Class, the standard specification includes heated seats as well as an armrest with a stowage compartment between the front seats. So there will be no complaints if a ride on board the G-Class occasionally lasts a little longer.



It's hard to believe that chrome isn't a precious metal

The Chrome package for the G-Class

The Chrome package allows you to underline the innate elegance of your G-Class. It comes as standard with the G 55 AMG and is available as an option for the G 350 BlueTEC and G 500. And you can cut a fine figure with the AMG radiator grille with chrome highlights. The interior is afforded an especially high-quality feel courtesy of the automatic transmission's selector lever which is framed in chrome, the uninterrupted chrome trim on the seat adjustment switch's wood panel and chrome rings around the speaker grille in the front doors. Another eye-catching detail is the chrome door sill panel in the load compartment featuring Mercedes-Benz lettering (AMG lettering on the G 55 AMG). So you're certain to draw admiring glances whether you're off the beaten track or about town.



The automatic transmission's selector lever framed in chrome

The G-Class takes your desire for freedom very seriously

With its exceptionally large boot capacity

Drivers who opt for a genuine off-roader generally have a burning desire for freedom. And the G-Class interior caters to this desire, offering a wealth of space. With the 50:50 folding rear seat bench in the Station Wagon and Cabriolet (1/3:2/3 in the long-wheelbase Station Wagon), the load compartment capacity of up to 2250 litres provides plenty of room even for a round-the-world trip, let alone a visit to the golf course. Just as you prefer.

For those who want even more space, the engine and chassis configuration allows a trailed load of up to 3.5 t. Whether you are towing a yacht, a horsebox or a caravan, the G-Class grants you smooth and swift passage almost regardless of the load and terrain.









A safe bet for even the most intrepid of explorers

On-board safety technology - from Mercedes-Benz

We laid the first milestone back in the 1950s with the invention of the safety passenger cell. Since then Mercedes-Benz engineers have come up with further safety-enhancing innovations year after year. And many of them feature in the G-Class.

They help to detect and control critical situations on and off the road in plenty of time. And they include numerous pre-crash preventive protection measures. Should an accident occur nevertheless, a whole host of passive safety features can be activated, so you can sit back and relax: with a G-Class the focus is on adventure rather than risky venture.

Companions you can count on

Safety-enhancing electronic assistance systems

When you take the wheel of a G-Class, you have already delegated some of the key tasks, thanks to a whole host of electronic aids which can be activated immediately in critical situations.

If the control unit in the G-Class detects a risk of the vehicle skidding, for example, the Electronic Stability Program ESP® springs into action immediately by reducing the engine torque, applying the brakes at one or more wheels and thus helping to stabilise the vehicle. If emergency braking is detected, Brake Assist (BAS) builds up the maximum braking pressure within fractions of a second, whilst the modified anti-lock braking system (ABS) developed specifically for the G-Class helps to ensure that the vehicle remains steerable and that its directional stability is maintained in an emergency. These electronic aids, together with the passive safety equipment on board, help to protect the occupants of the G-Class.



G-Guard

Special protection against the road's more out-of-the-ordinary dangers

The G-Class special-protection vehicles represent the very highest security standards, without compromising where comfort is concerned. The G-Guard's protective elements are deeply embedded in the body structure at the production stage, helping to ensure comprehensive all-round protection. They include numerous discreet safety details which can protect you in an emergency. Some 80 years of experience in protection technology and ballistics have been incorporated into the concept in close cooperation with international security authorities. In its glazed areas the G-Guard even offers protection levels of the highest protection classes VR6 and VR7.

The G-Guard is tested for resistance to projectile penetration in a series of ballistic tests. And it goes without saying that the car also passes all the usual Mercedes-Benz quality and safety tests. All the safety components – such as the electronic control systems, the brakes, the chassis and the suspension – have been adapted to take into account the vehicle's heavier weight. So the G-Guard protects you not only in an emergency – but also against the more everyday dangers you might encounter out on the road.



The G-Guard offers mobile protection in extreme situations. It has been tested and certified by internationally recognised authoritative institutions in accordance with the highest ballistic protection classes VR6 and VR7

AMG: absolute motoring genius

The G 55 AMG's powerful engine

AMG. Three magical letters that are synonymous with performance, prestige and passion. Each engine is produced by a single engineer who has a wealth of experience. They even put their signature on the engine tag. So you can be sure that the powerful 5.5-litre V8 supercharged engine at the heart of your G 55 AMG will continue to perform sterling service for many years to come.

Developing 373 kW, the powerplant propels the G 55 AMG from 0 to 100 km/h in 5.5 seconds. This superlative power delivery combines with the outstandingly agile handling dynamics to provide a scintillating level of performance that is matched only by the unique sound of the large-displacement V8, while the AMG high-performance braking system brings the vehicle to a halt quickly and safely.

The chassis of the G 55 AMG has been configured for sporty driving agility without restricting the vehicle's off-road capabilities. AMG specifications include extra-taut shock absorbers, for example.

G 55 AMG

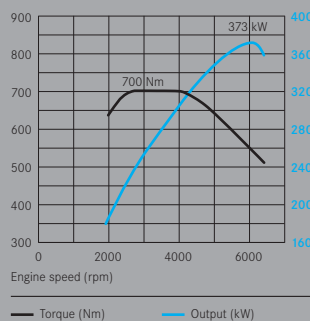

Full power ahead. The impressive torque of 700 Nm is available across a broad engine speed range from 2750 rpm to 4000 rpm



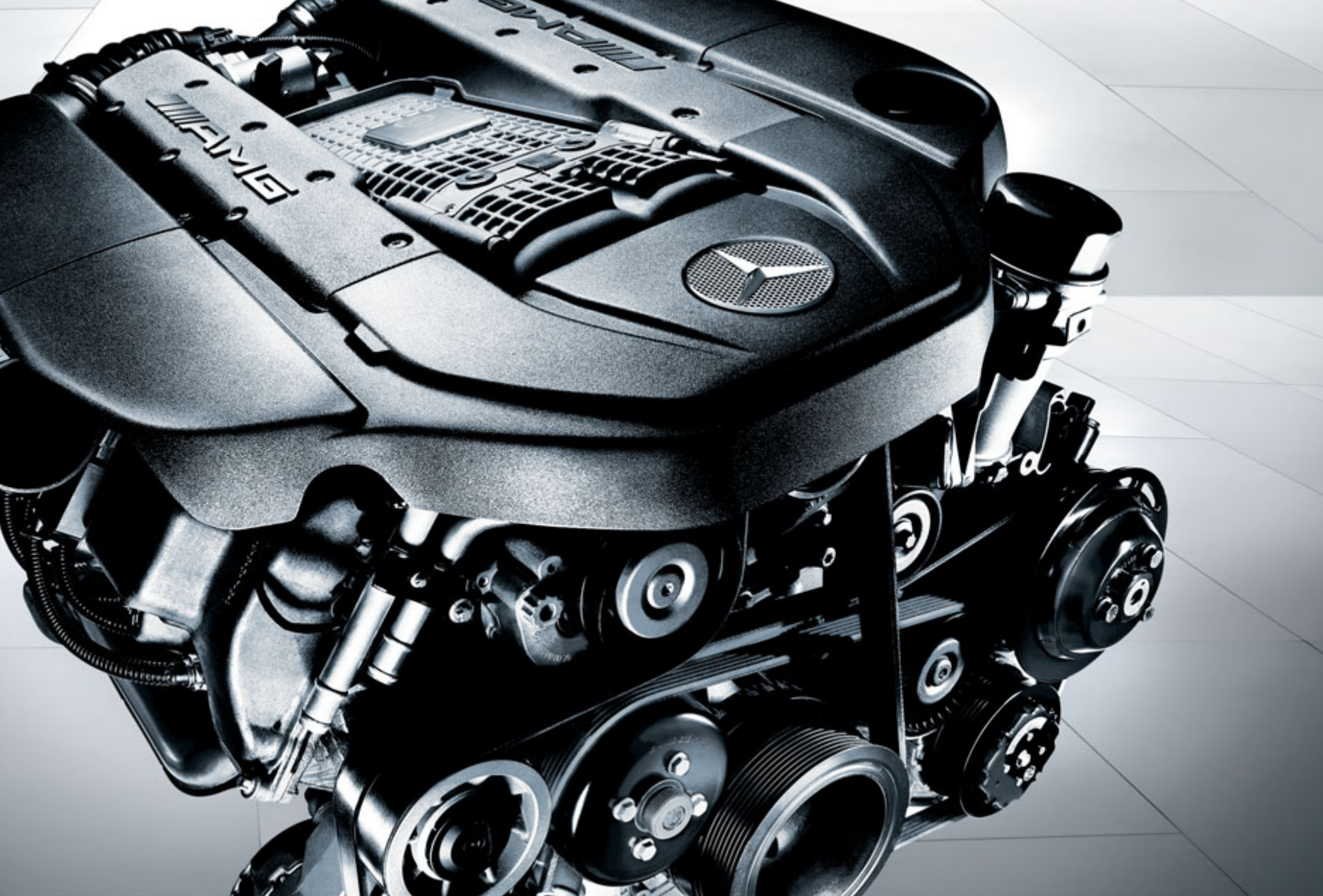

AMG: take it to the limit

The equipment for the G 55 AMG

With its distinctive exterior, the G 55 AMG cuts a fine figure wherever it goes, both on the road or way off it. Its eye-catching design, extravagant in true AMG fashion, includes 5-spoke light-alloy wheels with 275/55 R 19 tyres, the AMG exhaust system with twin tailpipes on both sides of the vehicle, wheel-arch flaring and the radiator grille with chrome highlights. In store for you in the interior are the Chrome package plus ambient lighting and a leather-covered dashboard.



Exhaust pipes

Add to this an AMG-specific instrument cluster, the G 55 lettering on the selector lever and stainless-steel illuminated door sills, serving to underline the vehicle's sporting ambitions.

The standard-specification designo leather appointments and the designo wood trim give you the opportunity to individualise your G 55 AMG at the highest level.



Instrument cluster









My G-Class





With the G-Class, you're off to an ideal start

Extensive range of equipment options for the G-Class

Perhaps the most impressive aspect of the G-Class's evolution is the level of equipment. That's because what initially started out as an off-roader for the purists has long been bestowed with all the creature comforts that people have come to expect from a Mercedes-Benz.

Even the standard-specification G-Class features numerous extras. The automatic climate control THERMATIC, for example, always sets precisely the interior temperature you require. Then there are the state-of-the-art audio systems which deliver sound quality par excellence – the Audio 20 CD radio in the G 350 BlueTEC or the COMAND APS multimedia system in the G 500 and G 55 AMG.

The range of optional extras available allows you to create just the G-Class you want. The reversing camera in conjunction with the ultrasonic reversing aid and the garage door opener integrated in the interior mirror are just two of the many other comfort and convenience-enhancing equipment options available for your G-Class.

No darkness, only light

The G-Class lighting concept

The distinctive face of the G-Class is characterised by the radiator grille divided up by 3 louvres. The design boasts clean-cut surfaces and straight lines. The hallmark circular headlamps have always provided a striking contrast to this. Featuring state-of-the-art bi-xenon technology, they illuminate a wide area of the road brightly, enabling you to see dangers and obstacles more clearly and well in advance. Additional front fog

lamps with an integrated cornering light function light up the road immediately in front of the vehicle and illuminate bends.

At the rear as at the front, the G-Class shines with an impressive light system including oval tail lights with a sophisticated LED look and the hallmark rectangular lighting units.

The exterior mirrors round off the lighting concept, with standard features including integrated indicator lamps and front area lighting. They are electrically adjustable and heated. What's more, the exterior mirror on the driver's side is automatically dimming, assuring you a clear view of other traffic at all times.



Exterior mirror



Bi-xenon headlamp



Tail light



Adaptability: the G-Class caters to your needs

Clear and practical: the G-Class controls and memory function

Everything in the G-Class can be controlled simply and intuitively: from the exterior mirrors to the central locking. This is not only practical and convenient, it also enhances safety at critical moments.

Clear lettering and functional controls quickly enable drivers to familiarise themselves with the G-Class – the automatic climate control system, for example, is extremely easy to use.

The standard equipment package for the G-Class also provides for infinitely variable adjustment and storing of the seat, head-restraint, steering-wheel and exterior-mirror positions for up to three people. One press of a button is all it takes for the G-Class to find your preferred settings: just one of many ways to personalise your G-Class.



Control panel for air conditioning



Memory function



Inner values matter to the G-Class

The interior: cleverly thought-out equipment and appointments coupled with timeless design

Clear, puristic lines lend the exterior of the G-Class its distinctive appearance. And there is a natural continuation of this design philosophy in the classically modern interior.

Beneath the pristine surface, however, lies state-of-the-art Mercedes-Benz technology: from the multifunction steering wheel to the

sophisticated hard-disc navigation system. Standard equipment for the G 350 BlueTEC includes the high-tech Audio 20 CD radio with a 6-disc CD changer, 12.7 cm display and an Aux-in socket in the glove compartment, while the range of audio options for the long-wheelbase Station Wagon includes the Harman Kardon® Logic 7® surround sound system with an

output of 450 watts, 12 loudspeakers and Dolby 5.1/DTS.

It's not just the technical equipment that displays the inner values of the G-Class. So do the stylish fine-wood and chrome trim elements that give the passenger compartment the perfect finishing touches.



Audio 20 CD radio



Door sill panel



Differential lock buttons

Standard equipment (selection)

12-volt sockets in front passenger footwell as well as in the rear or, in the case of the Station Wagon, in the load compartment
4 belt tensioners
7G-TRONIC automatic transmission/5-speed automatic transmission in the G 55 AMG
Airbags for driver and front passenger with seat occupancy sensor, long-wheelbase Station Wagon also features windowbags
Ambient lighting ¹
AMG light-alloy wheels, 275/55 R 19, painted titanium grey ¹
Anti-lock braking system (ABS) and Brake Assist (BAS)
Armrest between the front seats with integrated stowage compartment and compartment with sliding cover
ASSYST service interval indicator
Bi-xenon headlamps with automatic range adjustment and headlamp cleaning system
Cabriolet soft-top, black, electrohydraulically operated
Central locking with infrared radio remote control and interior switch
Chrome package ¹
COMAND APS multimedia system ^{1,3} /Audio 20 CD radio ²
Cruise control with variable speed limiter
Differential locks (transfer case, front and rear axle)
Door sill panels in stainless steel with "Mercedes-Benz" lettering
Electrically adjustable front seats with Memory function for seats, exterior mirrors and steering wheel
Electronic brake force distribution (EBD)
Electronic Stability Program ESP®
Electronic traction system for all-wheel drive (4ETS)

Exterior mirrors with integral indicators and front area lighting, electrically adjustable and heated and driver's mirror automatically dimming
Front fog lamps with integral cornering light function
"G-Line" fine wood trim in anthracite ² /burr walnut ³ /designo ¹ , centre console, dashboard and shift gate cover
Headlamp Assist
Heated seats (driver/front passenger)
ISOFIX child seat attachment points ⁴
Leather upholstery ³ , designo leather upholstery ¹ (door panelling in ruffled leather)
Light-alloy wheels, 265/70 R 162; 265/60 R 183
Load retainers in luggage compartment
Low-range gear reduction (electrically selectable while on the move)
Multifunction steering wheel and selector lever in leather ² , multifunction steering wheel and selector lever in leather/wood ^{1,3}
Permanent all-wheel drive with differential
Power windows
Rain sensor
Seat belts, 3-point design (five) in long-wheelbase Station Wagon
Seat belts, 3-point design (four) in short-wheelbase Station Wagon and Cabriolet
Split-folding rear bench seat (1/2 : 1/2) for short-wheelbase Station Wagon and Cabriolet
Split-folding rear bench seat (1/3 : 2/3) for long-wheelbase Station Wagon
Steering column electrically adjustable, automatic steering wheel adjustment to facilitate entry/exit
THERMATIC automatic climate control including dust and pollen filter
Trailer socket, 13-pin

¹ Standard specification for G 55 AMG² Standard specification for G 350 BlueTEC³ Standard specification for G 500⁴ Only for long-wheelbase Station Wagon

Leaves its mark where only few dare to tread

Reassuring: wheels with tyre pressure monitoring system

As well as transferring lateral forces, driving power and braking power to the road, the G-Class wheels also have to perform when there are no roads at all.

All models are available with an integral tyre pressure monitoring system as an optional extra. The electronic system checks the tyre pressure constantly whilst driving and immediately informs the driver of any detected pressure loss.



5-spoke light-alloy wheels with 275/55 R 19 tyres, titanium grey (standard for G 55 AMG)

Reveal a new side of your G-Class

The stylish light-alloy wheels for the G-Class

We can't reinvent the wheel. But that doesn't stop us from improving upon it. Our selection of light-alloy wheels is designed to further boost the appeal of your G-Class.

The standard-fit wheels feature a dynamic 5-spoke design. In addition, 6-spoke light-alloy wheels with a high-shine finish are available as optional extras for these models.

The light-alloy wheels painted in titanium grey are exclusively available for the G 55 AMG. Their striking design is the ideal match for this powerful variant and exudes stylishness from top to bottom.



5-spoke light-alloy wheels with 265/70 R 16 tyres
(standard for G 350 BlueTEC)



5-twin-spoke light-alloy wheels with 265/60 R 18 tyres
(standard for G 500, optional extra for G 350 BlueTEC)



6-spoke light-alloy wheels with 265/60 R 18 tyres
(optional extra for G 350 BlueTEC/G 500)

The G-Class carries on long after others have stopped

The optional extras

Although the G-Class comes with an extensive package of standard equipment, it goes one step further by offering an equally wide range of optional extras.

By way of example, the reversing camera attached at the rear in combination with the COMAND APS multimedia system and the ultrasonic reversing aid. The reversing camera not only proves its worth when parking but also when manoeuvring on terrain which might have a few surprises in store for you.



COMAND APS

COMAND APS boasts an array of impressive features, such as a 6-disc DVD changer, Birdview, a high-resolution 16.5 cm display and hard-disc navigation. Three years of free updates for your map data are already included (vehicle-specific, as of first registration). Further functions include the integrated voice-operated control system LINGUATRONIC, Traffic Message Channel (TMC), 4 GB memory for audio files and a slot for SD memory cards. With the optional Media Interface it is possible to integrate various mobile audio devices like an iPod® or USB stick into the control system.





Comfortable seats for an even better driving feel

The multicontour seat in the G-Class

The G-Class with its heated multicontour seats provides an outstanding level of comfort which is sure to be appreciated on long as well as short trips. The new multicontour seats have optimised ergonomic contouring and are individually adjustable for hardness. Several air chambers under the upholstery material allow you to adjust the multicontour seats precisely according to your own preferences. The chambers in the lumbar area, backrest side bolsters and front seat cushion can be inflated to provide you with excellent stability on almost any trip. To add that finishing touch in seating comfort, the multicontour seats for the driver and front passenger in the G-Class are climatized.



Side stowage box





Competition for the night sky

Ambient lighting from Mercedes-Benz

With this new type of interior lighting from Mercedes-Benz you'll find night-time journeys all the more enjoyable, and it gives added emphasis to the high-quality interior design of your G-Class.

The dimmable ambient lighting is part of the standard specification for the G 55 AMG, and it is available as an optional extra for the G 350 BlueTEC and the G 500. In addition to the instrument lighting, fibre optic cables in the door side trim panels and lamps in the footwell, door openers and stowage tray produce an especially cosy atmosphere. Together with the instrument cluster the brightness of the ambient lighting can be variably adjusted. The ambient lighting even goes out of its way to give you a warm welcome: to make getting into the vehicle even

more of a pleasure, the footwell is illuminated to the maximum extent when the front doors are opened. As soon as they are closed, the light is then dimmed again.



Illuminated door opener

Optional extras (selection)	Cabriolet wheelbase 2400	G 350 BlueTEC	G 500	Short Station Wagon wheelbase 2400	G 350 BlueTEC	G 500	Long Station Wagon wheelbase 2850	G 350 BlueTEC	G 500	G 55 AMG
Alcantara® roof lining in anthracite		–	–		–	–		●	●	□
Convenience Telephony in the armrest		●	●		●	●		●	●	●
Dashboard trimmed in black leather		●	●		●	●		●	●	□
Exclusive package¹ (ambient lighting, leather-trimmed dashboard, Seat Comfort package, illuminated door sill panels, Alcantara® roof lining in anthracite)		●	●		●	●		●	●	–
Exterior Stainless Steel package (side running boards left and right and spare-wheel cover with 3-D Mercedes-Benz star in stainless steel)		●	●		●	●		●	●	□
Harman Kardon® Logic 7® surround sound system		–	–		–	–		●	●	●
Heated steering wheel		●	●		●	●		●	●	●
Integral garage door opener in interior mirror		●	●		●	●		●	●	●
Media Interface (universal interface in glove compartment for various audio devices, e.g. iPod®, USB stick, etc., incl. consumer cable for iPod®, USB, AUX)		●	●		●	●		●	●	●
NECK-PRO luxury front head restraints, crash-responsive		●	●		●	●		●	●	●



Rear Seat Entertainment System



Ultrasonic reversing aid

Optional extras (selection)	Cabriolet wheelbase 2400	G 350 BlueTEC	G 500	Short Station Wagon wheelbase 2400	G 350 BlueTEC	G 500	Long Station Wagon wheelbase 2850	G 350 BlueTEC	G 500	G 55 AMG
Power-operated sliding sunroof		-	-		●	●		●	●	●
Privacy glass for rear door and load compartment windows, incl. tailgate		-	-		-	-		●	●	●
Rear Seat Entertainment System (17.8 cm monitors with integrated DVD player on the back of the front-seat head restraints, USB port, SD card slot, AV connection for iPod® or games consoles, two sets of infrared headphones, infrared remote control)		-	-		-	-		●	●	●
Reversing camera ²		-	-		●	●		●	●	●
Seat Comfort package ¹ (front multicontour climatised seats)		●	●		●	●		●	●	●
Sports exhaust system		-	-		-	-		-	●	-
Trailer coupling with ball-type head		●	●		●	●		●	●	●
TV tuner (for analogue/digital reception) ³		-	-		●	●		●	●	●
Ultrasonic reversing aid		●	●		●	●		●	●	●

● Available for an additional charge □ Standard equipment - Not available

¹ Only in conjunction with leather upholstery, Code SP3/SP4 or SP5, or designo leather

² Only in conjunction with COMAND APS, Code EU1, and ultrasonic reversing aid, Code J44

³ Only in conjunction with COMAND APS control and display system, Code EU1



Tyre pressure monitoring system

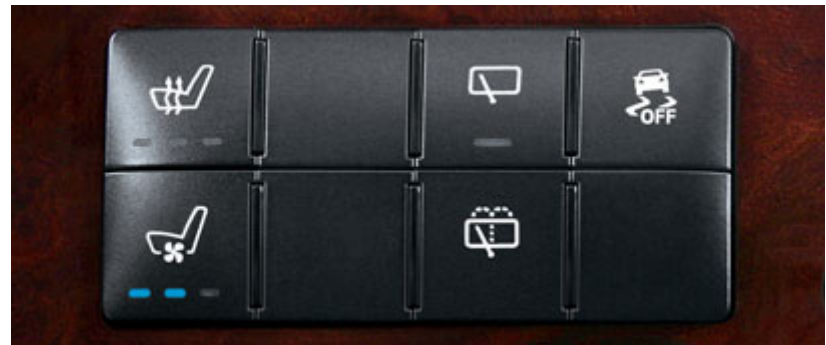

Climatised seats





The irresistible beauty of a beautifully resistant finish

The clearcoat with greater scratch resistance

1934. The first “Silver Arrow” must be the only Mercedes-Benz ever to have started out in life with less-than-perfect paintwork. When the Mercedes-Benz engineers put the newly developed W25 racing car on the scales before the Eifel Grand Prix at the Nürburgring in 1934, the car weighed 751 kg – 1 kg over the strict weight limit imposed by the international racing federation. “Well, that takes the shine off things,” mused Mercedes racing manager Alfred Neubauer – then realised he’d just put his finger on the solution. He promptly ordered the engineers to sand down the white paintwork, exposing the silver-coloured aluminium bodywork. This shed the necessary weight and the rest is history: Manfred von Brauchitsch won the race and it wasn’t long before the press were raving about the “Silver Arrows”, as they quickly dubbed them.

Of course, things wouldn’t have been so easy for the team if their car had been sporting today’s latest paintwork developed by Mercedes-Benz. This paint is much tougher than previous clearcoats, with a more durable, more intense sheen. Both the metallic and non-metallic clearcoats are more scratch-resistant and less susceptible to weather and environmental influences, like precipitation, sunlight, fluctuating temperatures, dust or soot.



Who said adventures couldn't be luxurious?

The interior appointment variants for the G-Class

Leather is an elegant, natural material that is durable and easy to look after. It is ideal for everyday use or on long trips. Best of all, it has an attractive look and a soft feel. There is a choice of leather appointments in black, grey or chestnut (optional for the G 350 BlueTEC and standard for the G 500). But whichever one you choose, having seats in leather will clearly emphasise the exclusivity of your G-Class.

The designo leather appointments (standard for the G 55 AMG) impart a particularly luxurious charm to your G-Class. Seats, head restraints and interior trim are available in eleven colour tones, with the door panelling in ruffled designo leather. You can add the finishing touch to the exclusive interior appointments of your G-Class with the roof lining in fine anthracite Alcantara® and a dashboard covered with leather.



Grey leather



Chestnut leather



Where robustness meets elegance

The select fabric range

The G 350 BlueTEC features the tried-and-trusted, high-quality fabric covers in grey and black with attractive new patterns as standard. Woven from selected textiles, they are an excellent match for the interior design of the G-Class. The fabrics are particularly hardwearing, and prove how elegant robustness can be.



Grey fabric

The G-Class

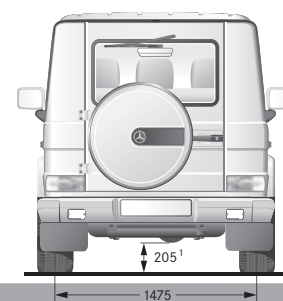
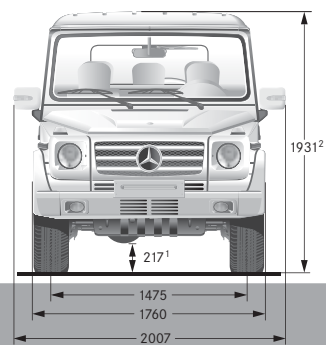
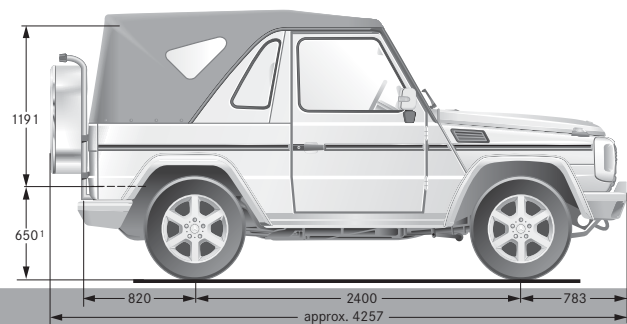
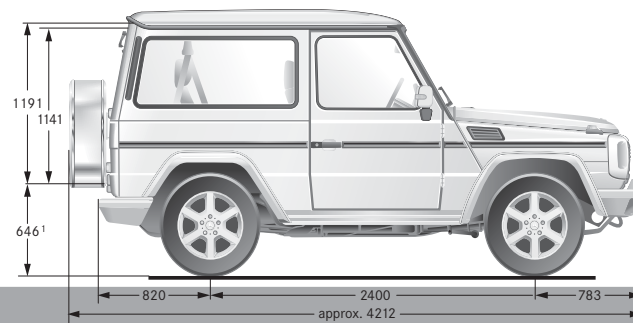
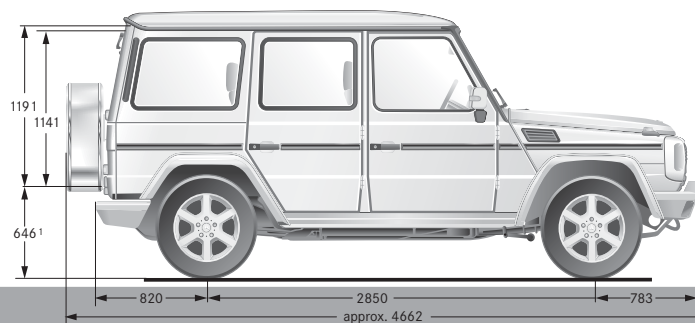

The dimensions shown are mean values (in mm) and apply to standard-specification vehicles carrying three occupants weighing 68 kg each

¹With maximum permissible payload ²Height of Cabriolet: 1941 mm

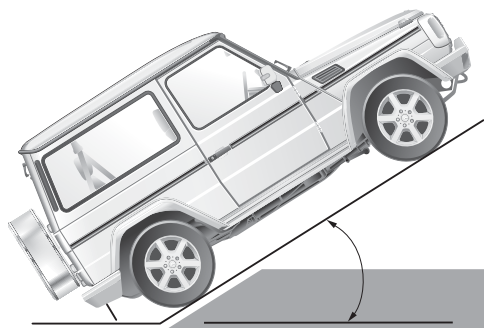

Slope-climbing ability up to 80%, depending on terrain

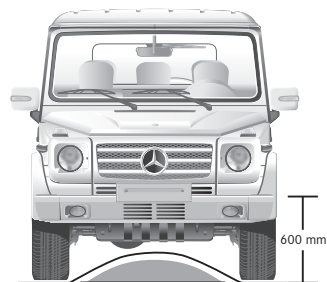

Ground clearance 210 mm
Max fording depth 600 mm



Directionally stable on lateral slopes up to 54%

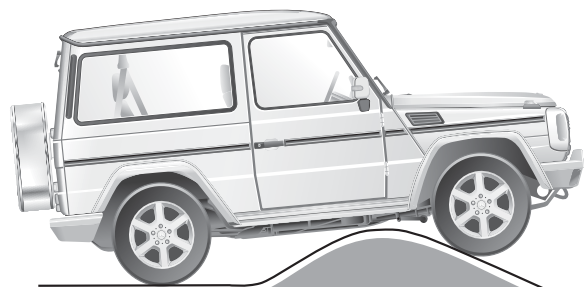

Large ramp angle



Angle of approach 36°/departure 27°

Anyone opting for a Mercedes buys far more than just a car

Comprehensive service offered by Mercedes-Benz

Mercedes-Benz Museum. 125 years of automotive history in one place – this is what awaits you at the Mercedes-Benz Museum in Stuttgart. Experience the unique excitement and embark upon a thrilling journey through time. Housed inside an architecturally impressive building, over 1500 exhibits on nine levels give you an insight into the unique tradition and powers of innovation of the Mercedes-Benz brand. You can see the world's first two automobiles in the shape of the Benz Patent-Motorwagen (motor car) and the Daimler motorised carriage – both from the year 1886. Two linked circuits take you from the beginnings of the automobile, past a series of unforgettable classics, through more than 100 years of motor racing history and, finally, on to a glimpse of what the future holds – all in an area covering a total of 16,500 square metres. Enjoy the unique brand experience. We look forward to your visit. More information is available at www.mercedes-benz-classic.com/museum

MercedesCard. Your ticket to the Mercedes-Benz experience: four times a year we will send you exciting details of a selected range of events and services which we have put together exclusively for you. Then there is the Mercedes Magazine with its fascinating reports and articles. But the MercedesCard also has many other uses: as a VISA credit card, it is an internationally accepted means of payment. Plus the card offers further benefits to provide you with peace of mind, such as Mercedes-Benz insurance. You can also gain free entry to the Mercedes-Benz Museum simply by showing your VISA MercedesCard. Further information can be found at www.mercedes-benz.de/mercedescard¹

Mercedes-Benz Bank. If you have already chosen your dream car and want to remain financially flexible, you should make us your next port of call, whether it be for leasing, finance, insurance or service packages. Our “Private Leasing plus” scheme is a complete package comprising leasing, third-party insurance and fully-comprehensive insurance. “Business Leasing plus” for business customers works in much the same way, while our “Plus3 Financing” combines the low repayment rates of a financing scheme with the flexibility of leasing. You then have three options at the end of the contract: you can keep the car, sell it or return it to us for a guaranteed price and switch to a new model. We can also offer a range of investment products such as fixed-interest products, savings plans, investment funds or depository receipts. For details, please call 0681 96595000 or visit www.mercedes-benz-bank.de

Mercedes-Benz mobility. There will always be a helpful passenger in your new car: the assurance of carefree driving. Should you ever need assistance, however, the Mercedes-Benz Service24h is there for you. Just call the freephone service hotline on 00800 1 777 7777². The newly integrated telematics service Mercedes-Benz Contact³ is even more customer-friendly: a touch of a button is all it takes to contact the Mercedes-Benz customer centre by phone. And if you wish all the relevant vehicle and position-related data can be sent at the same time, ensuring the fastest possible reaction time and rapid on-the-spot help. As standard and at no extra charge: the Mercedes-Benz mobility package Mobilo⁴. Whether you have lost your key, have had a breakdown which cannot be repaired immediately or if the vehicle is damaged as a result of an accident or vandalism, Mobilo gets you to your destination – anywhere in Europe, even if the vehicle is damaged as a result of an accident or vandalism.

Should a repair take a little longer, we will even cover the cost of an overnight stay. But don't get too excited – after all, it's very rare for a Mercedes to break down. Whatever the nature of your problem, one thing is sure: you will soon be able to resume your journey.

Service packages. Vehicle-specific services allow you to put together an individual package for your Mercedes, including long-term protection against unforeseeable repair costs and high-quality servicing with genuine Mercedes-Benz parts. You can also count on the extensive network of Mercedes-Benz workshops, where you will receive the usual high standard of service for your Mercedes at a predictable, fixed price. Please ask your Mercedes-Benz dealer for further details.

¹ Information about the MercedesCard in Austria and Switzerland can be found on the Mercedes-Benz websites for these countries

² Mobile phone rates vary according to service provider

³ Requires a factory-fitted radio linked up to a switched-on mobile phone. For the cost of a call to the landline network maintenance is carried out by your Mercedes-Benz service partner

⁴ When the warranty has expired Mobilo can be extended by another year for a maximum of 30 years, provided that regular

Time for another enriching experience

A Mercedes-Benz is most at home on the road. This is the only way to experience the effortlessly superior driving feel that lends every Mercedes model its inimitable class. Feel the power of efficient engines with low fuel consumption and precise steering, designed to put you right in the mood for driving. And experience what true comfort really is. The unique feeling of driving a Mercedes cannot be put into words, however. Which is precisely why we'd like to invite you to take a test drive. Your Mercedes-Benz dealer will be happy to make all the necessary arrangements for you. Simply visit www.mercedes-benz.com to locate the nearest Mercedes-Benz dealer in your country or region. We look forward to seeing you.

The website also offers an interactive tour, enabling you to take a closer look at your desired model. These informative clips are the ideal way to acquaint yourself with your dream car. You can view key functions in detail, gain an insight into the car's inner workings or look at the benefits of each model. For further details, visit www.mercedes-benz.de/owners-manual

Now your mobile phone acts as a gateway to the whole Mercedes-Benz world. In addition to an overview of all passenger car models, there are insights into the entire brand world, not to mention a wealth of entertainment offers and direct links to a range of services at www.mercedes.mobi



	Non-metallic paints		Metallic paints										
	black	calcite white	chromite black	obsidian black	periclase green	lazurite blue	tanzanite blue	flint grey	peridot brown	thulite red	iridium silver	palladium silver	sandine beige
G 350 BlueTEC fabric, standard specification													
black	●	●	●	●	●	●	●	●	●	●	●	●	●
grey	●	●	●	●	●	●	●	●	○	●	●	○	○
G 350 BlueTEC leather, optional extra													
black	●	●	●	●	●	●	●	●	●	●	●	●	●
grey	●	●	●	●	●	●	●	●	○	●	●	○	○
chestnut	●	●	●	●	○	○	●	○	●	○	●	●	●
G 500 leather, standard specification													
black	△	△	●	●	●	●	●	●	●	●	●	●	●
grey	△	△	●	●	●	●	●	●	○	●	●	○	○
chestnut	△	△	●	●	○	○	●	○	●	○	●	●	●

● Recommended ○ Possible △ Not possible

Roof lining
(long-wheelbase Station Wagon)



Alcantara® in anthracite^{3,4}

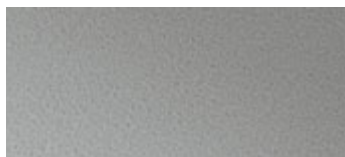

grey velour^{1,2}

Upholstery

Fabric¹



black



grey

Leather^{2,5}

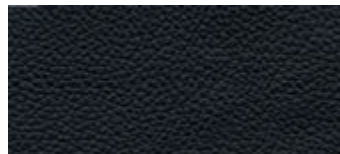

black



grey

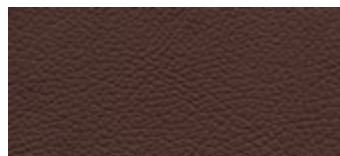

chestnut

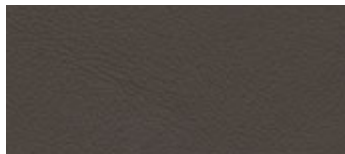
designo leather^{3,4}

ZF2 designo corteccia



ZF5 designo classic red



ZJ5 designo chablis



ZK8 designo mystic red

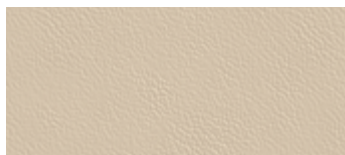

ZF3 designo porcelain

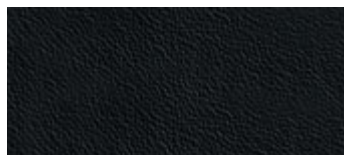

ZF7 designo black

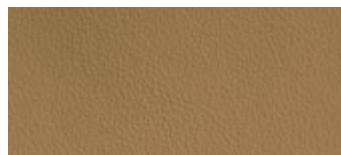

ZK6 designo sand



ZL1 designo mauritius blue



ZF4 designo marron

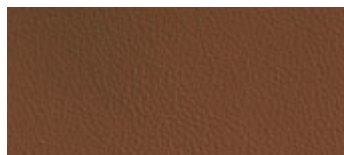

ZH2 designo light brown

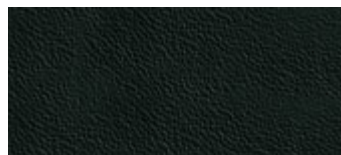

ZK7 designo graphite green

¹ Standard specification for G 350 BlueTEC

² Standard specification for G 500

³ Optional extra for G 350 BlueTEC and G 500

⁴ Standard specification for G 55 AMG

⁵ Optional extra for G 350 BlueTEC

Wood trim

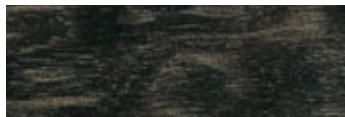
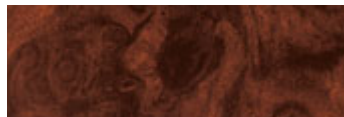
High-gloss anthracite "G-Line" wood¹High-gloss brown burr walnut wood^{2,3}

Wood/leather steering wheel and selector lever

VL1 high-gloss brown burr walnut wood^{2,3}

designo trim

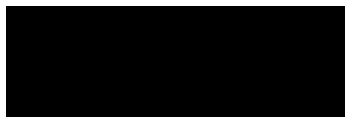
ZG2 designo black piano lacquer wood^{4,5}

designo wood/leather steering wheel and selector lever

ZG3 designo black piano lacquer wood^{4,5}

designo trim

ZM0 designo brown natural maple grain wood^{4,5}

designo wood/leather steering wheel and selector lever

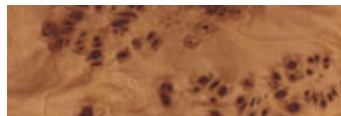
ZM9 designo brown natural maple grain wood^{4,5}ZM5 designo anthracite poplar wood^{4,5}ZM5 designo anthracite poplar wood^{4,5}ZM5 designo light brown natural poplar wood^{4,5}ZM6 designo light brown natural poplar wood^{4,5}

ZN0 designo natural matt oak grain wood

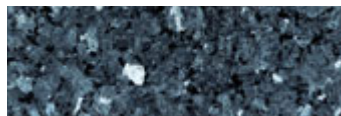

ZR0 designo natural matt oak grain wood

ZG4 designo labrador blue pearl stone⁶ZG3 designo black piano lacquer wood⁶¹ Standard specification for G 350 BlueTEC⁴ Optional extra for G 350 BlueTEC and G 500² Standard specification for G 500⁵ Standard specification for G 55 AMG³ Optional extra for G 350 BlueTEC⁶ Optional extra for G 350 BlueTEC, G 500 and G 55 AMG

Non-metallic paints



040 black

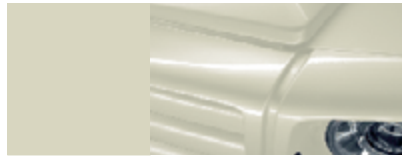

650 calcite white

Metallic paints



112 chromite black



197 obsidian black



300 periclase green

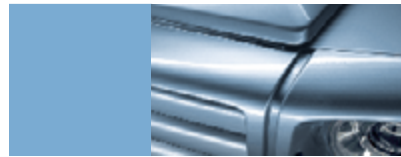

349 lazurite blue



359 tanzanite blue

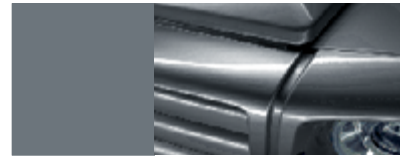

368 flint grey

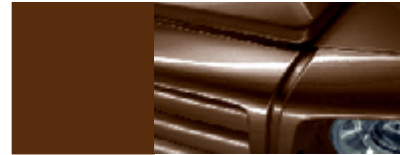

474 peridot brown



541 thulite red

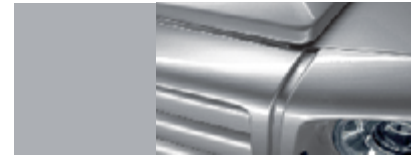

775 iridium silver

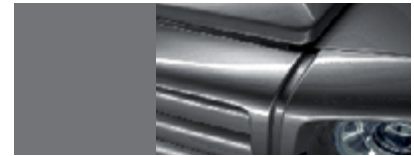

792 palladium silver



798 sanidine beige

designo paints

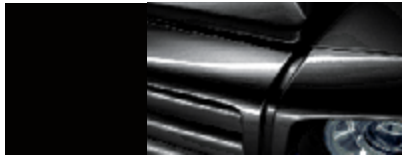

033 designo mocha black

designo mystic paints



032 designo mystic blue

designo magno paints



051 designo magno platinum



041 designo graphite



037 designo mystic red

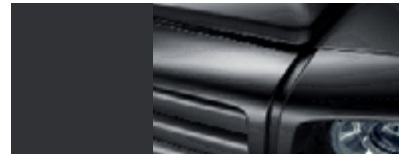

056 designo magno night black



046 designo platinum black



052 designo mystic brown

	G 350 BlueTEC		G 500		G 55 AMG
No. of cylinders/arrangement	6/V		8/V		8/V
Bore/stroke (mm)	83.0/92.0		98.0/90.5		97.0/92.0
Total displacement (cc)	2987		5461		5439
Rated output ¹ (kW at rpm)	155/3400		285/6000		373/6100
Rated torque ¹ (Nm at rpm)	540/1600–2400		530/2800–4800		700/2750–4000
Top speed, approx. (km/h)	175		210		210 ²
Tyre size	265/70 R 16		265/60 R 18		275/55 R 19
Fuel consumption ³ (l/100 km) urban/extra-urban/combined	Diesel 13.6/9.8/11.2		Premium petrol 19.3/12.0/14.7		Premium petrol 21.4/12.7/15.9
Tank capacity (l)	96		96		96
CO ₂ emissions ³ (g/km) combined	297		351		378
EU emissions standard	Euro 5		Euro 5		Euro 5
	Cabriolet	Short-wheelbase/long-wheelbase Station Wagon	Cabriolet	Short-wheelbase/long-wheelbase Station Wagon	Long-wheelbase Station Wagon
Acceleration 0–100 km/h (s)	8.8	9.1/9.1	5.9	5.9/6.1	5.5
Kerb weight ⁴ (kg)	2285	2300/2500	2300	2315/2445	2580
Payload (kg)	565	550/700	550	535/755	620
Permissible gross vehicle weight (kg)	2850	2850/3200	2850	2850/3200	3200
Towing capacity unbraked (kg)	750	750/750	750	750/750	750
Towing capacity braked incl. drawbar load, 115 kg short wheelbase	2850 ⁵	2850 ⁵ /–	2850 ⁵	2850 ⁵ /–	–
140 kg long wheelbase	–	–/3500 ⁶	–	–/3500 ⁶	3500 ⁶
Gross combination weight (kg)	5700	5700/6700	5700	5700/6700	6560

¹ Figures according to Directive 80/1269/EEC in the currently applicable version ² Electronically governed ³ The figures shown were obtained in accordance with the prescribed measuring process (Directive 80/1268/EEC in the currently applicable version). The figures are not based on an individual model and do not constitute part of the product offer; they are provided solely for purposes of comparison between different vehicle models ⁴ Figures according to Directive 92/21/EC, version 95/48/EC (kerb weight with fuel tank 90% full, driver, 68 kg, and luggage, 7 kg) for standard-specification vehicles. Optional extras and accessories will generally increase this figure and reduce the payload capacity accordingly

⁵ Statutory requirements met for 12% gradient at 2850 kg ⁶ Statutory requirements met for 12% gradient at 3500 kg

Take-back of end-of-life vehicles. Coming full circle. At the end of its long life, you can return your G-Class to us for environment-friendly disposal in accordance with the EC End-Of-Life Vehicle Directive¹. But that day lies a long way off.

¹Applies in accordance with national regulations to vehicles up to 3.5 tonnes gross weight. Mercedes-Benz passenger cars have met the statutory regulations governing the suitability of their design for reuse and recycling for a number of years now. A network of vehicle take-back depots and dismantlers has been established which will process your vehicle in an environment-friendly manner. The ways in which both vehicles and parts can be recovered are subject to ongoing development and improvement. Consequently, the G-Class will be able to comply with any future increases in the recycling quota within the stipulated time limits. For further information, please call 00800 1 777 7777

Please note: changes may have been made to the product since this brochure went to press (10.06.2010). The manufacturer reserves the right to make changes to the design, form, colour and specification during the delivery period, provided these changes, while taking into account the interests of the vendor, can be deemed reasonable with respect to the purchaser. Where the vendor or the manufacturer uses symbols or numbers to describe an order or the subject of an order, no rights may be derived solely from these. The illustrations may show accessories and items of optional equipment which are not part of standard specification. Colours may differ slightly from those shown, owing to the limitations of the printing process. This brochure is distributed internationally. It provides a general indication of the range of models, features, optional extras, colours and/or services available in various countries. Some of the models, features, optional extras, colours and/or services may not be available in your country, or may only be available in a different specification. Additionally some models, features, optional extras, colours and/or services may only be available in combination with others. For current and more specific information in relation to the range of models, features, optional extras, colours and/or services available in your country, and their pricing, you should contact your nearest authorised Mercedes-Benz Passenger Car Dealer. www.mercedes-benz.com