

This Brochure is prepared by Daimler AG and it predominantly reflects the capabilities and performance of vehicles sold in Europe. Some characteristics, capabilities, performance features and optional extras (e.g. towing systems) may not be available or may not apply in Australia or under Australian conditions. The information in this Brochure is therefore indicative, illustrative and provided only for guidance and should not be relied on. To obtain current and accurate information on a vehicle and any options applicable to Australia, contact your local authorised Mercedes-Benz dealer.



Mercedes-Benz

The M-Class



Mercedes-Benz

“Our philosophy is very simple. We give our best for people who expect the best.”

Dr Dieter Zetsche

Contents

The M-Class	4	My M-Class	46
Exterior design	8	Equipment	48
Agility	16	Sports packages	48
BlueEFFICIENCY	16	Audio and communication systems	50
Diesel engines	18	Standard equipment	54
Petrol engines	20	Optional extras	56
Transmission	22	Equipment packages	58
Suspension	24	Light-alloy wheels	60
Comfort	26	Genuine accessories	62
Interior	26	designo	64
Flexibility	32	Services	68
Off-road capability	34	Colours and materials	72
Off-Road Pro Engineering package	34	Upholstery, leather and trim	72
4ETS and ESP®	37	Paintwork	75
Safety	38	Technical data	73
Integral safety concept	38		
AMG optional extras	42		

When you feel like a change from the highway, it'll let you go your own way

Whether you're cruising on bustling city streets or have a rocky trail ahead of you: with the M-Class you can enjoy effortlessly superior driving performance on all sorts of different surfaces, paved or not.

The M-Class has looks to match its impressive off-road capability: its particularly exclusive and dynamic exterior is complemented perfectly by the design of the interior. Fine materials and exceptional workmanship, advanced technology – as practical as it is good-looking – and inviting seats set the tone inside.

The M-Class demonstrates versatility at a very high level – and we're not just talking about ground clearance.

The M-Class





Take the long way home





A civilised answer to the call of the wild

Taking up challenges can be so exhilarating. Especially if you tackle them with the M-Class.

The front section, with a radiator grille featuring black louvres and chrome trim, immediately signals determination. Equally striking are the exterior mirrors and the silver-coloured simulated underguard. The front apron with its impres-

sive visual width and the optionally available LED daytime running lamps and bi-xenon headlamps complements the muscular character of the M-Class.

In fact, its looks alone are enough to inspire you to give in to your curiosity and indulge your spirit of adventure.





Style and substance in perfect harmony

Muscular wings with brush guards dominate the side view of the M-Class. They define the characteristic contour of the vehicle's dynamic silhouette. The standard roof rails are a clear signal of versatility. The appearance of the M-Class is effectively enhanced by powerful-looking 7-spoke light-alloy wheels as standard, sporting 235/65 R 17 tyres; on the ML 500, a 5-spoke design is standard with 255/50 R 19 tyres. As you can see, the M-Class is an extremely good-looking vehicle. But that's only part of the story. You will find that its true character is revealed not at first glance, but on the first drive.





Yet another stunning view
(and the scenery's not bad either)





Some trips you just remember. Others are unforgettable

From the moment you start the engine to the time you set the parking brake at your destination, there is one M-Class attribute that will stand out: excitement. The very look of the vehicle promises flexibility, dynamism and exclusivity, from the front section through the characteristic wedge-like line of the side to the tail end. The panoramic rear window, which extends into the sides of the vehicle, and the discreet spoiler lip seem almost weightless. Dark-tinted tail lights add a distinctly sporty touch. And if you wish, your M-Class can shine even more brightly when

viewed from the rear: with optional LED tail lights.

The reflectors in the rear bumper, which is painted in the vehicle colour, make for improved visibility. But before dark, it's more likely to be the twin exhaust system with oval tailpipes – or square tailpipes as part of the Sports package – that catches the eye. Its design brings to mind a sports car – as will the sense of exhilaration you feel after driving the M-Class.





BlueEFFICIENCY – fast forward to tomorrow

We are quicker at getting environmentally friendly future technologies to where it matters most: on the road. As the inventor of the motor car, Mercedes-Benz has a special responsibility – one we have undertaken with all our might for many years. By the end of 2010, we will be able to offer you over 85 models with BlueEFFICIENCY technologies, all of which place far less of a burden on the environment – without compromising on safety, comfort and driving enjoyment.

Our BlueEFFICIENCY concept comprises innovations for efficient mobility as well as optimised processes all the way along the value chain. They involve different approaches, but they all have a common goal: to make your individual mobility as sustainable as possible.

The BlueEFFICIENCY measures – the Mercedes-Benz efficiency package. This package consists of comprehensive vehicle optimisations designed to save fuel and ease the burden on the environment. Each model combines the most

efficient engine with latest-generation aerodynamic and energy-management measures to minimise fuel consumption. Such measures include intelligently controlled ancillaries, tyres with optimised rolling resistance, lightweight components and the ECO start/stop function, which is being made available for an increasing number of models. The new BlueDIRECT V6 and V8 petrol engines in the S-Class, CL-Class and CLS-Class, for example, reduce fuel consumption by up to 24% yet have a much higher power output.

BlueTEC – the clean diesel. Mercedes-Benz has brought to market BlueTEC technology for diesel engines based on common-rail direct injection (CDI). A modular emission-control system makes BlueTEC an exceptionally clean diesel technology, as not only does it remove up to 95% of the particulate from the exhaust gases, it also reduces nitrogen oxides by up to 90%. All that remains is essentially water, harmless nitrogen and the satisfying feeling of having helped to ease the burden on the environment.

HYBRID – the intelligent combination of petrol and electric drive. A well-established team makes a lot of things easier. And this is certainly true in the case of HYBRID technology. Here the electric motor is used for the recuperation of braking energy, which is stored in the battery. When needed, this energy is returned to the electric drive, which assists the petrol engine when the car is accelerating. What's more, the ECU shuts off the petrol engine when the speed falls below 15 km/h. In this way, a HYBRID can reduce fuel consumption by up to 20%. So it looks



The BlueEFFICIENCY measures bring about a substantial reduction in fuel consumption and CO₂ emissions



after the environment as well as your bank balance. Perfect teamwork, you might say.

BlueTEC HYBRID – clean diesel combined with electric drive. It marries the benefits of the HYBRID with those of BlueTEC: during braking, the kinetic energy is converted into electrical energy, which can be re-used when required. At the same time, the BlueTEC technology cleans the exhaust gases and removes many of the pollutants. All of which makes the economical diesel powerplant even more efficient, agile and clean.



Taking the E-Class as a basis, we are using **BlueTEC HYBRID technology** to develop the first diesel hybrid in this class

Innovative drive systems that break new ground: E-CELL and F-CELL. Mercedes-Benz has developed these two locally emission-free drive systems. The B-Class F-CELL is already being produced on a small scale and has been displaying its everyday practicality on Germany's roads since mid-2010. It uses hydrogen to produce power for the electric motor in a fuel cell. The first models from a small series of the A-Class E-CELL – featuring an electric motor which draws its energy from two lithium-ion batteries, giving it an average range of more than 200 km –



The A-Class **E-CELL** allows locally emission-free driving with a battery-powered electric motor

will start to roll off the production line at the end of 2010. There will also be an E-CELL PLUS, which will include a small internal combustion engine (Range Extender) to increase the range of the electric vehicle.

But that is not all: under the banner “Design for Environment”, we also look at a vehicle's entire lifecycle and work hard to preserve the environment from the planning stage right through to recycling. The same applies to the building and running of new plants. In addition, we are heavily involved in the development of alternative fuels and carry out research in the field of bionics. In short, BlueEFFICIENCY is good news for both you and the environment.

Further information about our comprehensive measures can be found at:

www.mercedes-benz.com/blueefficiency

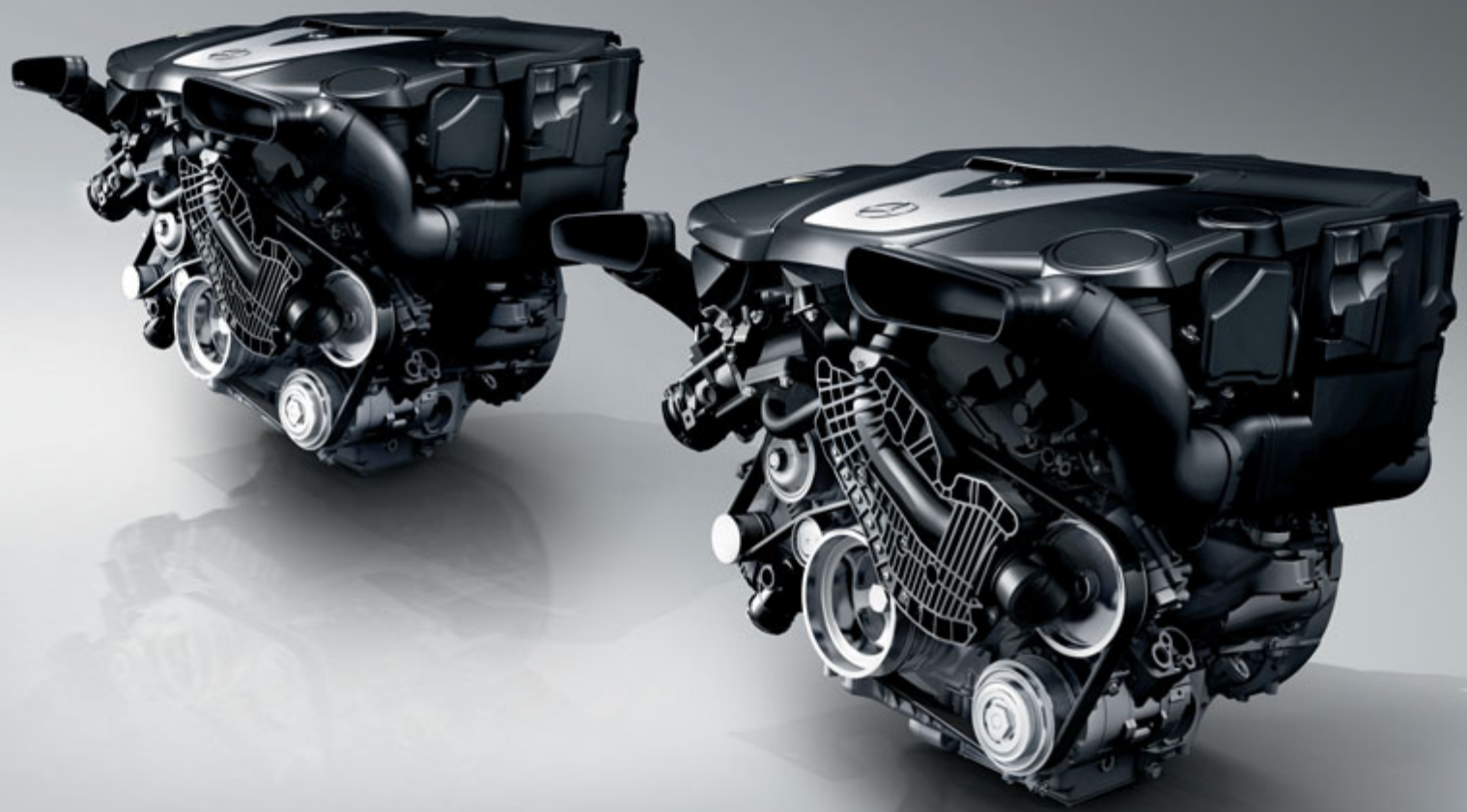

Common rail – to get the most out of fuel

The leading diesel technology

Anyone who enjoys exploring the great outdoors knows how important it is to respect the environment. This mindset is also reflected by the M-Class. Its diesel engines, which are equipped as standard with a particulate filter, are designed to run quietly and offer good fuel efficiency which results in low emissions. Yet they are also decidedly powerful: the ML 300 CDI 4MATIC

BlueEFFICIENCY develops 150 kW and a maximum torque of 500 Nm.

In the ML 350 BlueTEC 4MATIC, you have an output of 155 kW and a peak torque of 540 Nm on tap.

The diesel engines are particularly economical thanks to their optimised common-rail technology.

This means that, when the engine is running, the necessary injection pressure is always available in a central fuel line. It is stored there and put to work as required by individually controlled valves. There isn't a great deal to see, but you notice it in the engine's smooth running characteristics, at the filling station, and – in the long term – in the environment.

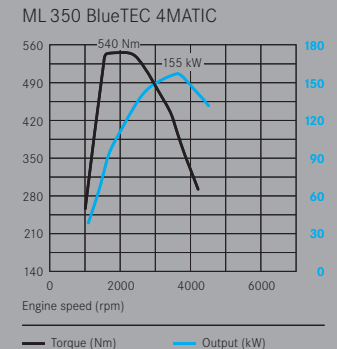
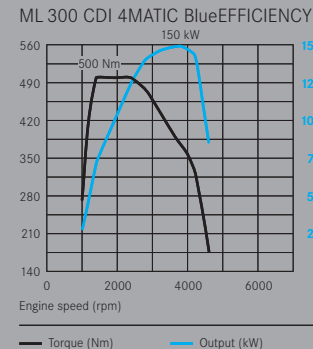

The power to inspire you

The dynamically responsive petrol engines

The ignition of these powerplants gets more than the M-Class moving. You too will be moved, even if you're not driving.

The petrol engines are particularly powerful, yet they consume less fuel than many other vehicles in this class.

The 6-cylinder unit in the ML 350 4MATIC stands out for its tremendous refinement. Delivering 200 kW at 6000 rpm and a peak torque of 350 Nm between 2400 and 5000 rpm, it propels the M-Class from 0 to 100 km/h in 8.4 seconds.

High torque and the typical V8 sound characterise the mighty 8-cylinder ML 500 4MATIC. With 285 kW at 6000 rpm and a maximum torque of 530 Nm, available between 2800 and 4800 rpm, it can sprint from 0 to 100 km/h in only 5.8 seconds.

With the power reserves of the 6- or 8-cylinder drive units you're perfectly placed to cover any distance – or to cope with a climb of several dozen metres up a dirt track, for instance.

ML 350 4MATIC

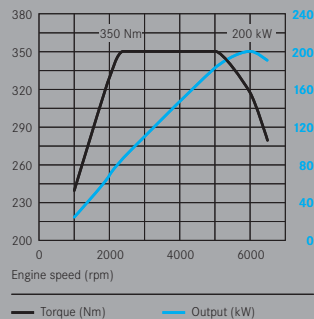

ML 500 4MATIC

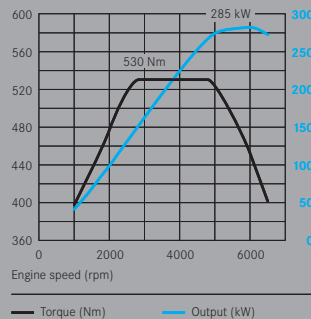



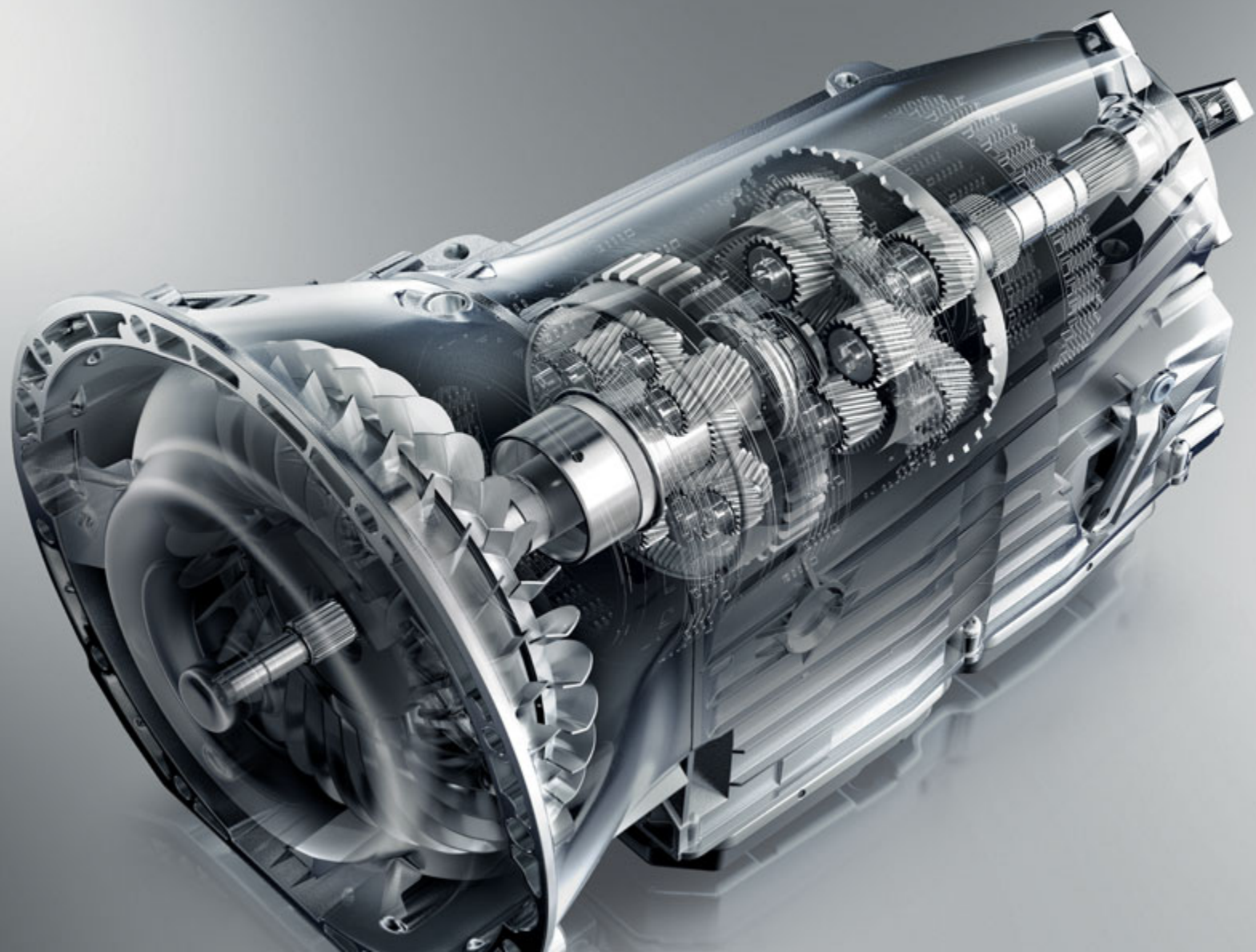

A strong transmission for strong acceleration

The 7G-TRONIC with multiple downshift functionality

To make full use of its power, an engine needs a highly responsive transmission. When the two work together as well as they do in the M-Class, the result is the height of driving refinement. On the road and off it.

Crucial to this interaction is the enhanced 7G-TRONIC automatic transmission. It selects

gears directly and very briskly, ensuring greater pulling power and optimum acceleration.

The 7G-TRONIC automatic transmission has seven gear ratios. As the differences in engine speed between the individual ratios are very small, both driving dynamics and ride comfort are enhanced. Gearshifts are virtually imperceptible, shift times

are unbelievably short, and noise is minimal. Even when shifting down, the 7G-TRONIC automatic transmission affords greater refinement thanks to the multiple downshift function that skips individual gears if required. As a result, it brings you closer than ever to the perfect driving experience. But then, that's what you would automatically expect from a Mercedes-Benz.

Responsive technology

Sensitive to changing surfaces: 4MATIC, 4ETS and AIRMATIC air suspension

Ice and snow, leaves and mud, grass and loose chippings – the surfaces may change, but ride comfort and driving safety are constant factors. This is due principally to the fact that the M-Class has exceptional traction at all times thanks to the interplay of the 4MATIC permanent all-wheel drive, the electronic traction system 4ETS, and the AIRMATIC air suspension, including the Adaptive Damping System ADS. 4MATIC trans-

fers drive power evenly to the axles and wheels. Instead of differential locks, it uses the electronic traction system to do this. If a wheel begins to spin, 4ETS brakes it. Unused drive torque is distributed to the other wheels. The result: the best possible traction and high ride quality. The AIRMATIC package is fitted as standard in the ML 500 4MATIC. The sensors of the Adaptive Damping System ADS monitor the driving situ-

ation along with the air suspension response. You can also choose manually between sporty and comfort-oriented damper settings. Finally, you can prime all the electronic systems for off-road driving simply by pressing the standard off-road switch. So now you'll find routes opening up to you where previously there were none.

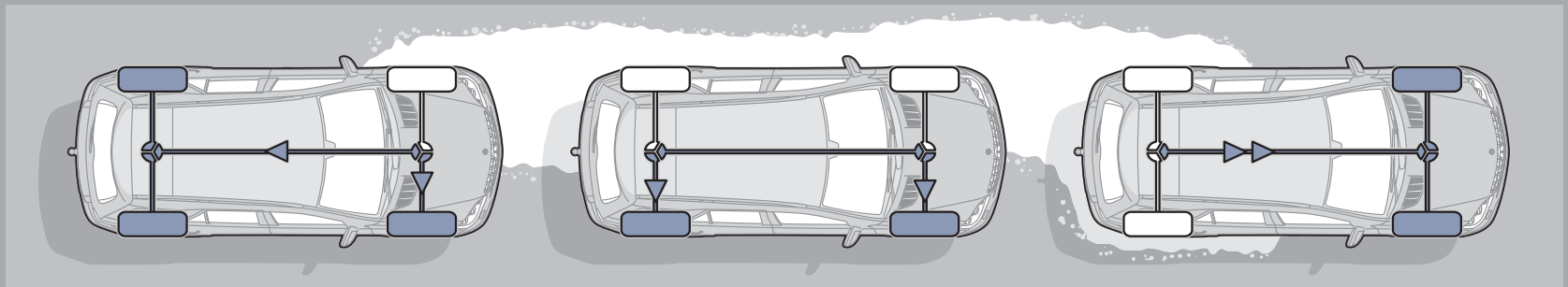

4ETS automatically transfers the drive to the wheels with most grip







The M-Class lets you enjoy some very special places. Starting with its own interior

The interior - as practical as it is luxurious

What is it about some places that gives people a profound sense of wellbeing? For us, it's simply the feeling you get that everything is exactly as it should be - the cockpit of the M-Class being a case in point.

Intuition is practically all you need to operate many of the electronic functions. The particularly ergonomic arrangement of all the displays and controls is the key. And to keep you from searching too long to find your way, the range of options includes the COMAND APS multimedia system with hard-disc navigation, which is available in place of the standard Audio 20 CD audio system.

Comfortably installed in the ergonomically designed and electrically adjustable seats, you'll find that even a long journey will seem remarkably short. Customers seeking even greater luxury can equip the M-Class with climatized multicontour seats which include the Memory package, allowing three stored configurations to be recalled at the push of a button.

So you can just get into the M-Class and let the vehicle's systems and ergonomic design take the effort out of searching for everything from your favourite radio station to the ideal seat position.

Even in the big city you're surrounded by nature

Style aplenty, but nothing superfluous: the cockpit

Sometimes you feel at home even though you still haven't reached it. In the interior of the M-Class, for example. Open the door and it receives you with an elegant, sporty design, warm colours, and a welcoming ambience.

The first thing that catches your eye is the standard multifunction leather steering wheel with

chrome highlights and shift paddles, which allow you to effortlessly flick through the gears. For those seeking even greater exclusivity, a wood/leather multifunction steering wheel in high-gloss anthracite poplar wood or high-gloss brown burr walnut wood is also available. The door centre panels are covered with high-grade, very easy-care ARTICO man-made leather,

which is also available as an option for the dashboard trim.

You can take the natural look and feel even further with our range of optional leather upholstery in various colours. Contrasting cashmere beige/black, for example, gives the interior design a particularly distinctive touch.





Made for long journeys and long legs

Plenty of space and a high level of comfort for the rear passengers

Legroom and headroom to spare: the spaciousness afforded by the rear passenger compartment of the M-Class makes long journeys a pleasure, even for tall passengers.

The rear seats are ergonomically shaped, promote a healthy posture and provide good support, not least when cornering. The raised seat position also contributes to the high level of passenger comfort. The clear view to the exterior from the back seats helps to banish boredom on long

trips, especially in conjunction with the optional Rear Seat Entertainment System. This includes: large screens with a diagonal size of 20.3 cm mounted on the front head restraints plus two sets of wireless headphones. A games console and TV receiver can be hooked up by means of an Aux-in socket.

As you can see, the three rear seats of the M-Class leave nothing to be desired. Except perhaps the chance of a turn at the steering wheel.



Volume control

Like business class for luggage: the load compartment

It's good to know that the M-Class lets you take along just about anything you care to. The stowage facilities, compartments and nets in the cockpit and the rear easily accommodate countless items.

For added stowage space, or when you need to carry bulky items, the rear seats can be split 1/3 to 2/3 or folded down entirely. If you also fold up the seat cushions, you can obtain a load capacity of as much as 2050 litres.

The M-Class also proves to be extremely accommodating when it comes to the loading process itself. The large wide-opening tailgate pivots upwards (power opening is available as an option) while the low sill makes it easy to put heavy loads on board.

As an optional extra you can also equip the load compartment with the load-securing rails of the EASY-PACK load-securing kit. Load-securing rings, a telescopic bar and a belt reel can be inserted and positioned at various points in the rails.

There are six permanently fitted load-securing rings as standard which allow you to tie down luggage in the load compartment. You can also stow a part of the load in a stowage space underneath the load compartment floor. So just about everything that has room in your life fits into the M-Class too. The only thing there's no room for is compromises.

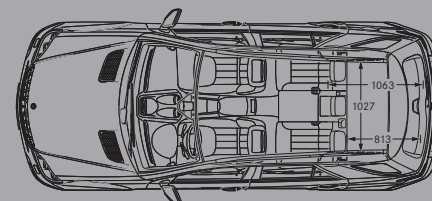

5 seats

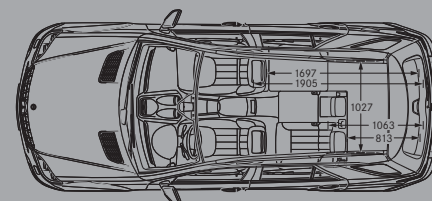

4 seats

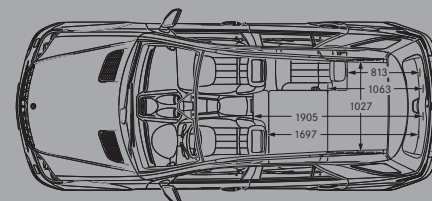

3 seats

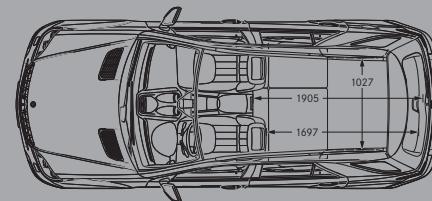

2 seats



For others it's an expedition. For you it's a short cut

Extended off-road capability thanks to the Off-Road Pro Engineering package

If you have a real thirst for adventure and plan to explore extreme terrain, the optional Off-Road Pro Engineering package allows you to give the M-Class so much cross-country prowess that it is able to tackle even the most treacherous terrain. In models equipped with the AIRMATIC electronically controlled damping system, it is possible to raise the vehicle's ride height by up to 90 millimetres and so attain a fording depth

of 600 millimetres. AIRMATIC is standard in the ML 500 4MATIC.

The underguard included in the package defies loose stones, rocky crags and deep puddles. Thus equipped, the M-Class has angles of approach and departure of up to 31° and can take a 35° cross-slope tilt angle in its stride. Even gradients as steep as 1 in 1 can be overcome thanks to a two-speed transfer case with a low range.

The 7G-TRONIC automatic transmission can be switched over to manual mode while on the move or standing still with the Off-Road Pro Engineering package. Once in manual mode, gears are selected by means of paddles on the steering wheel.

All of this helps make you feel at home, no matter how far off the beaten track the Off-Road Pro Engineering package takes you.

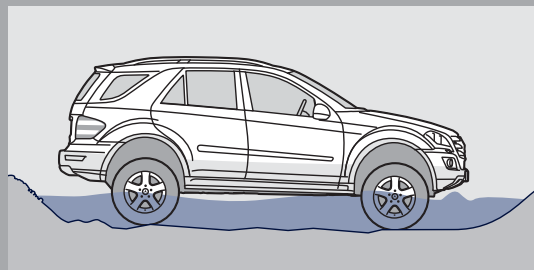

Maximum fording depth: 600 mm

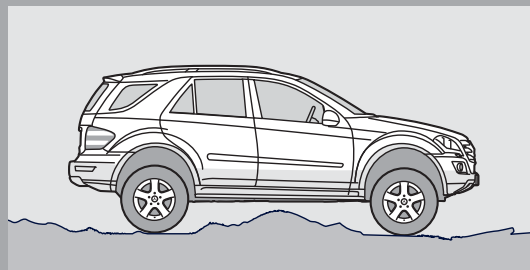

Maximum ground clearance: rear axle 299 mm, front axle 291 mm

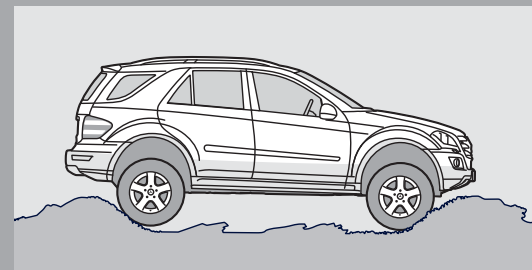

Maximum angles of: departure 30° , approach 33°





Plain sailing: 4MATIC with ESP®

All-wheel drive and trailer stabilisation – technology that pulls together

Although a stretch of sea is one of the few obstacles which the M-Class is unable to overcome, the Mercedes Off-roader is the ideal way of getting to the water, especially if you have a boat in tow. For one thing, there's the manually folding trailer coupling. And then there are all the advanced technical features: take the electronic traction system 4ETS and the Electronic Stability Program ESP®, for example, which enhance safety in challenging driving situations, as well as

incorporating additional driving safety systems in the form of ABS, ASR and active yaw control. In combination with 4MATIC, the permanent all-wheel drive system, this makes for outstanding traction on practically any surface. The optional Off-Road Pro Engineering package also demonstrates outstanding qualities when towing, particularly on slippery surfaces like wet grass and soft sand, or when starting off on hills.

The ESP® trailer stabilisation function can help to bring critical situations under control when towing. Through selective braking of individual wheels it can keep the towing vehicle and trailer on course and reduce fishtailing. For an altogether calmer journey – even if things are about to get a little rough out at sea.



Mercedes-Benz



4MATIC

S ON2609

Take your lead from the M-Class

Drive safe, stay safe – anticipatory occupant protection

Always on the look-out for any hazards which may arise, the safety systems on board the M-Class employ sensors, anticipatory technology and rapid reactions to help avoid critical situations and prepare for an imminent collision.

In addition to the Electronic Stability Program ESP®, the electronic traction system 4ETS as well as 4MATIC and PRE-SAFE®, a large number of sensors that monitor vehicle behaviour and the driving situation watch over your safety. If they perceive the risk of an accident, the side windows and the sliding sunroof (optional) can be closed automatically and the front seat belts pre-tensioned.

If the tyres suffer a drop in air pressure, the tyre pressure loss warning system notices the

change immediately and informs you. A tyre pressure monitoring system is available as an option.

The optionally available Blind Spot Assist provides an increased level of safety when changing lanes. If the system detects another vehicle in the danger zone, a red warning triangle illuminates in the exterior mirror. If the driver still indicates to change lanes, an additional warning tone sounds.

There is, however, one thing which your subconscious is able to register more effectively than any sensor: the marvellous feeling of reassurance which comes from driving one of the safest off-roaders in its class.

We've put our heads together to keep yours safe

Prepared for virtually every eventuality - where danger lurks and in case of an accident

We've built the M-Class around a rigid passenger cell to keep you as safe as possible in the event of an accident. The vehicle also has energy-absorbing crumple zones and reinforced doors. The raised floor level complements the integral safety concept which is designed to help protect you from severe shocks and jolts in the event of an accident. The head and neck areas are afforded particular protection: not only are there adaptive airbags that trigger in two stages depending on the collision's predicted severity and characteristics, the front seats also feature NECK-PRO head

restraints which automatically move towards your head when an impact from the rear is registered to actively guard against the risk of whiplash injuries.

Windowbags for all occupants are fitted as standard, while sidebags are provided in the front. Crash-absorbing elements in the footwell as well as kneebags for the driver come with all models too - as does our sincere hope that you need never have to rely on any of these features.



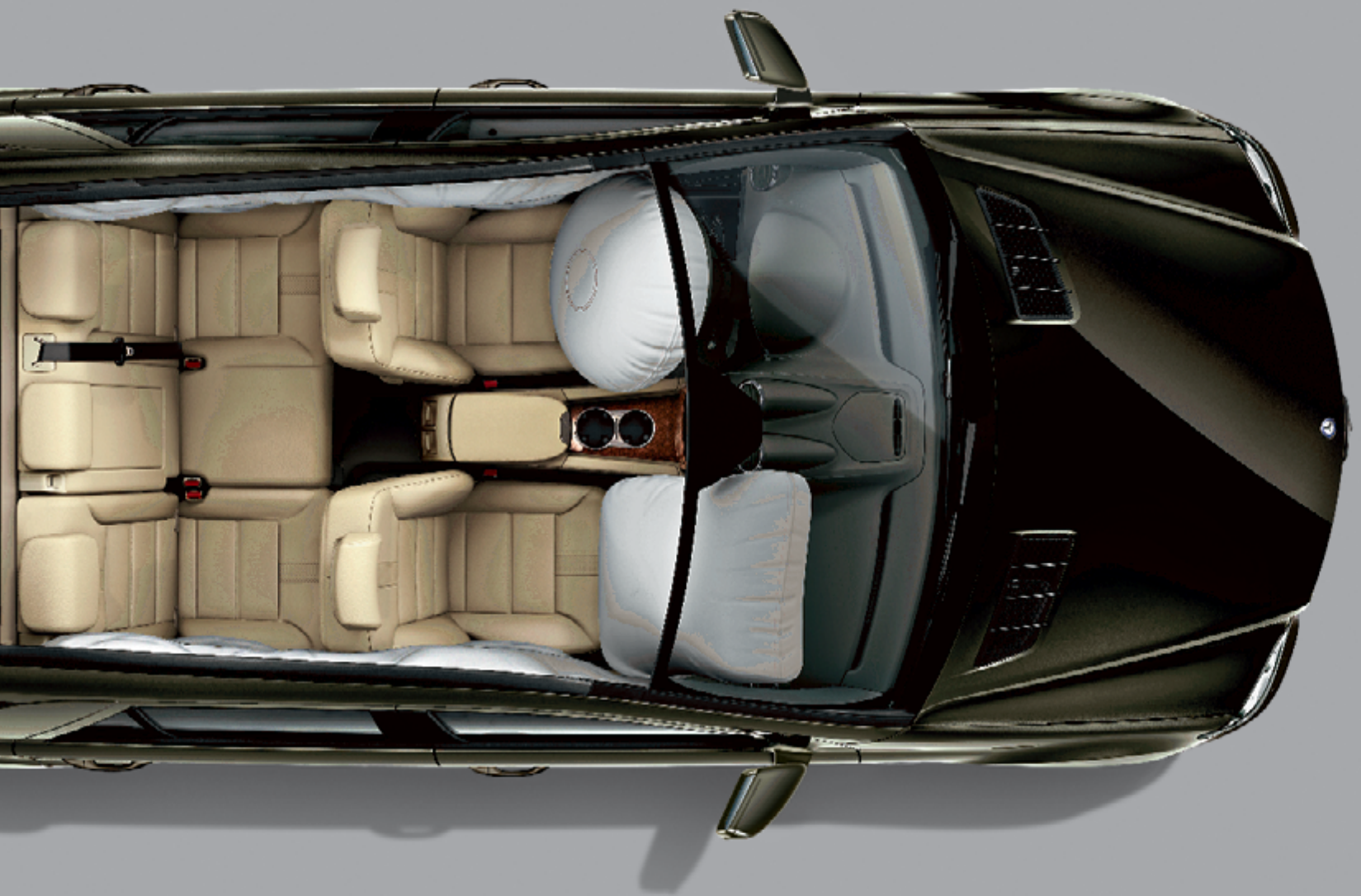

Pass with distinction

The AMG bodystyling

Impressions can be heightened by the way you express yourself – with the AMG bodystyling for your M-Class, for example. The AMG front apron with a simulated underguard in matt chrome adds special emphasis to the sporty side of this exceptional off-roader.

Viewed from the front, too, the AMG bodystyling makes a lasting impression with its large, racing-style air intakes.

The result is a vehicle with a presence which leaves no questions unanswered, except perhaps this one: Could anything be better looking?







ML 500



Imagine a wonderful moment that never ends

The AMG bodystyling and the AMG light-alloy wheels with 265/40 R 21 tyres

High-impact features are essential to the unique AMG chemistry. The powerful AMG rear apron with its matt chrome underguard is every bit as expressive as the front apron, while AMG-style oval, chromed tailpipes with AMG lettering complete the stunning look.

The dynamic and sporty aura is further accentuated by the vehicle's large high-sheen 5-spoke AMG light-alloy wheels shod with 265/40 R 21 tyres.

My M-Class





Crowned in chrome

For even sharper looks: the Exterior and Interior Sports packages



If you want to show your passion for the sporty side of life wherever you go, we warmly recommend the Exterior Sports package. It turns the M-Class into a study in dynamism. Chrome trim emphasises its exclusivity with blue-tinted glass and square chromed tailpipes striking an especially expressive note. The simulated underguard gleams in stainless steel, the roof rails have a stylish aluminium look and the sterling-silver-painted radiator grille shines with chrome highlights. Already impressive with its powerful 5-twin-spoke light-alloy wheels with 255/50 R 19 tyres, the M-Class takes on an even

more distinctive and incisive look with the optional 5-twin-spoke light-alloy wheels with 265/45 R 20 tyres or high-shine 5-spoke AMG light-alloy wheels with 265/40 R 21 tyres.

The Interior Sports package ensures that the inside of the vehicle also makes a very athletic impression. Brushed stainless steel sports pedals with rubber studs complement the electrically adjustable sports seats, upholstered in a combination of Alcantara® and ARTICO man-made leather, to create an irresistibly compelling ambience.



RADIO

DISC

NAVI

TEL



SYS



ON



18:10

2km



48°46'07"N



9°08'27"E

0m

0

1

QW

2

ABC

3

DEF

4

GHI

5

JKL

6

MNO

7

PQRS

8

TUV

9

WXYZ

* +



0



#



C



If you want something from your M-Class, just talk to it

COMAND APS – sophisticated technology for simple operation and control

The COMAND APS multimedia system on board the M-Class combines all entertainment and navigation functions into a central unit. Three years of free map updates are already included (for specific vehicle from date of initial registration). The generously sized and ergonomically positioned 16.5-cm colour display is ideal for following navigation instructions or watching a movie. If you opt for the TV tuner you can even watch television here.

You can navigate your way throughout Europe thanks to the integral hard disc which includes 4 GB of memory for audio files in MP3 or WMA format. The CD/DVD drive for audio or video is within easy reach, and the optional Media Interface allows you to connect COMAND APS with any USB data source or your iPod®. If you don't want to listen to music, you can always talk to your M-Class. With the voice-operated control system LINGUATRONIC, which is standard with

COMAND APS and optional for the Audio 50 APS, your M-Class is always listening out for your spoken commands for functions like the radio or telephone. And the system is even able to cope with regional dialects.

Now your MP3s can ride in a Mercedes too

The M-Class audio systems

The audio systems impress with user-friendliness, high performance, and a range of functions. A standard-fit feature is the Bluetooth® hands-free system. An Aux-in socket for portable audio devices such as an iPod® is also integrated. Available as an optional extra, a Media Interface can connect your external music memory with the audio control system of the M-Class. The music tracks can then be displayed in the instrument cluster or on the colour display in the centre console, and conveniently selected using the multifunction steering wheel's buttons.

Audio 20 CD offers a CD drive as standard, Audio 50 APS a DVD drive; both feature speed-sensitive volume control, a colour display, a twin tuner for improved radio reception and a telephone keypad.

You can enjoy a genuine surround sound experience with the optionally available latest-generation Harman Kardon® Logic 7® surround sound system. With 610 watts, 12 loudspeakers and a digital signal processor (DSP) it ensures exceptionally clear and pleasurable listening.

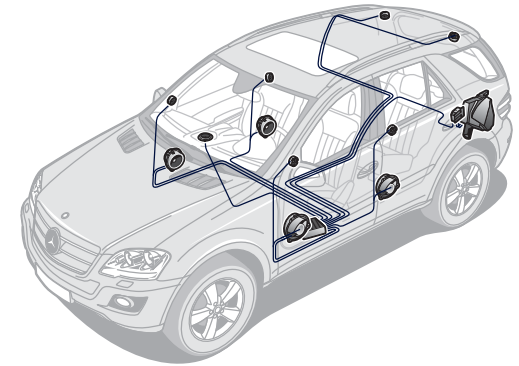

Specially positioned high-performance loudspeakers deliver an incomparably rich sound



RADIO DISC

⏪ TEL

🔊 SYS

📞

⏮ ⏭

ON

TA
FM 92.2 MHz
• SWR1 Bw | 2. SWR4 S
SWR3
• SWR2 Bw | • 89.5 MHz
Radio Speicher Klang

1 QWERTZ
2 ABC
3 DEF

4 GHI
5 JKL
6 MNO

7 PQRS
8 TUV
9 WXYZ

* 0 #
+ ⏪ ⏩

↶ C

⬆ ⬇ ⬅ OK ➡

18 20 22 24 26
AUTO

🌬 MAX

🌀

🛡

22

Even “standard” means something special

Standard equipment

Like the roads and tracks it can take you along, the M-Class itself is something special. Take the standard-fit off-road switch in the centre console, for example. This feature ensures that rough roads and gravel tracks never become problematical as it allows you to simply prime the M-Class to

handle them. An agreeable temperature is ensured by the THERMATIC automatic climate control. And even changing gear becomes a pleasure rather than a chore thanks to the DIRECT SELECT gearshift paddles on the steering wheel. For your enhanced safety the front seats are

equipped with crash-responsive NECK-PRO head restraints which can guard against whip-lash injuries following a collision from the rear. And for some musical accompaniment, simply switch on the Audio 20 CD audio system and enjoy!



The THERMATIC automatic climate control ensures an agreeable climate on board



DIRECT SELECT steering-wheel shift paddles and selector lever

STANDARD EQUIPMENT (SELECTION)

 4MATIC permanent all-wheel drive

 5-spoke light-alloy wheels with 255/50 R 19 tyres (ML 500)

 7G-TRONIC automatic transmission

 7-spoke light-alloy wheels with 235/65 R 17 tyres
 (ML 300 CDI BlueEFFICIENCY, ML 350 CDI, ML 350 BlueTEC, ML 350)

 Adaptive brake lights

 Airbags for driver and front passenger, with two-stage deployment

 Anti-lock braking system ABS

 Armrest in front, with compartment

 Audio 20 CD (with colour display, MP3 capability and Bluetooth® hands-free system)

 Aux-in connection in the glove compartment, for external audio devices

 Brake Assist (BAS)

 Dark-tinted tail lights

 DIRECT SELECT gearshift with steering-wheel gearshift paddles

 Direct-Steer system (speed-sensitive power steering)

 Door centre panel in ARTICO man-made leather

 Downhill Speed Regulation (DSR)

 Electronic Stability Program ESP®

 Electronic traction system 4ETS for all-wheel drive

 Exhaust system, twin-pipe, with exposed tailpipes

 Exit lights (4) in front and rear doors

 “Fasten seat belt” warning for front seats

 Front fog lamps

 Headlamp Assist

 Heated exterior mirrors, electrically adjustable

 Kneebag for driver

 Load compartment cover

 Nappa leather multifunction steering wheel

 NECK-PRO head restraints for front seats

 Outside temperature display

 Power windows (4) with one-touch control

 PRE-SAFE® system

 Rear bench seat, split-folding (1/3 : 2/3)

 Roll-over sensor

 Roof rails/pre-installation for roof-mounted carriers

 Sidebags for driver and front passenger

 Simulated front underguard, silver-coloured

 THERMATIC automatic climate control

 Third brake light featuring LED technology

 Tyre pressure loss warning system

 Windowbags for driver, front passenger and rear passengers

If you want it, we've probably already thought of it

Optional extras

OPTIONAL EXTRAS (SELECTION)

SAFETY

Anti-theft alarm system with tow-away protection

Bi-xenon headlamps with active light function, headlamp cleaning system, dynamic headlamp range adjustment, cornering light function in bumper and LED tail lights in clear-lens design

Blind Spot Assist, can be deactivated

Crash-responsive exit aid (in combination with Memory package)

Headlamp cleaning system

Sidebags in rear

COMFORT

Auxiliary heater

EASY-PACK load-securing kit with load-securing rails and removable rear seat cushions

EASY-PACK tailgate, hydraulically operated (can also be closed by pressing button on vehicle key)

Electrically adjustable 4-way lumbar support

Electrically adjustable front seats, with Memory package
(driver's seat, steering column and exterior mirrors electrically adjustable, with memory function)

Heated seats for driver and front passenger

Heated windscreen washer system including heated washer nozzles

Multicontour seats for driver and front passenger

PARKTRONIC

Sliding glass sunroof, electric

THERMOTRONIC luxury automatic climate control

Trailer coupling, folding or removable

Windscreen wipers with rain sensor (standard for ML 500)

RADIO/COMMUNICATION

Audio 50 APS (plus DVD arrow-based navigation and intersection zoom)

CD changer for 6 CDs, MP3-compatible

COMAND APS, control and display system for audio, navigation and telephone, incl. 16.5-cm display, hard-disc navigation, MUSIC REGISTER and voice-operated control system LINGUATRONIC

DVD changer for 6 DVDs

Harman Kardon® Logic 7® surround sound system with 12 loudspeakers

Rear Seat Entertainment System

DESIGN

5-spoke AMG light-alloy wheels with 265/40 R 21 tyres, high-sheen

AMG bodystyling

Dark-tinted glass for rear side windows and rear window

Dashboard in ARTICO man-made leather

Tyre pressure monitoring system

Wood/nappa leather multifunction steering wheel

Aluminium-look running boards

Your wish is our command: equip your M-Class with even more exclusive appointments, such as the Rear Seat Entertainment System featuring large screens with a diagonal size of 20.3 cm,

two sets of wireless headphones and a remote control. Or with a two-tone leather interior complete with black roof liner. The driver will also appreciate the DISTRONIC automatic proximity

control – and the parking comfort afforded by the PARKTRONIC parking aid.



The Rear Seat Entertainment System with two screens on the front head restraints



Electric sliding glass sunroof

If you like the idea of driving a highly exclusive Mercedes but don't have time to ponder over every detail of its equipment, the M-Class has the answer.

Compiled to meet the most sophisticated requirements, the equipment packages and Sports packages are always a good choice. The only thing you have to decide now is which of the packages suits you best.



Dashboard in designo black leather



Wood/nappa leather multifunction steering wheel



LED tail light in clear-lens design



Aluminium-look running boards

Exterior

AIRMATIC package (standard for ML 500)

Air suspension front/rear with level control, Adaptive Damping System (ADS)

AMG bodystyling

Front and rear apron with underguard in matt chrome, AMG oval tailpipes (chromed)

See pages 42 to 45

Exterior Sports package

Chromed square tailpipes, roof rails in aluminium look, chrome trim (rub strip, shoulderline trim strip), chromed load sill guard on rear bumper, sterling silver radiator grille with chrome, 5-twin-spoke light-alloy wheels (4), 8 J x 19 ET 60, tyre size 255/50 R 19, simulated underguard front and rear (stainless steel), dark-tinted windows

Off-Road Pro Engineering package

Two-speed transfer case with additional low-range reduction gearing, automatic or manually selectable multiple-disc limited-slip centre differential with up to 100% lock, manually selectable multiple-disc limited-slip rear-axle differential with 100% lock, front-axle locking as required with 4ETS brake intervention, extended adjustment range for air suspension system (30-mm increase in ground clearance versus AIRMATIC package), selectable transmission control mode (Standard "S" or Manual "M"), compass, underguard

Interior

Interior Sports package

Front sports seats, electrically adjustable, with 4-way lumbar support on driver's side, sports instrument cluster, Interior Light package (illuminated door handle recesses front and rear, illuminated stowage compartment and illuminated cup holder in front centre console, footwell lighting in rear); Alcantara® / ARTICO man-made leather upholstery combination with contrasting stitching and five-section cross-piping; brushed stainless steel sports pedals with rubber studs (incl. foot-operated parking brake)

designo

See pages 64 to 67

Perfect right down to the ground

Depending on the engine there are nine different wheel designs available for the M-Class, beautifully highlighting the off-roader's character.



5-spoke AMG light-alloy wheel, high-shine with 265 / 40 R 21 tyres (optional)



7-spoke light-alloy wheel with 235/65 R 17 tyres (standard for V6 models)¹



5-twin-spoke light-alloy wheel with 255/50 R 19 tyres (included in the Sports package)



5-spoke light-alloy wheel with 255/50 R 19 tyres (standard for V8 models)²



5-spoke light-alloy wheel with 255/55 R 18 tyres (no extra charge)²



5-spoke light-alloy wheel, mixed-size tyres, 255/50 R 19 at front and 285/45 R 19 at rear³



5-twin-spoke light-alloy wheel with 265/45 R 20 tyres³

¹ Except ML 350 BlueTEC: 17-inch 10-spoke light-alloy wheel

² Optional for V6 models

³ Optional



Make more of your M-Class

Driving a Mercedes is not merely enjoyable – it can also be very practical. The roof carrier system from the range of genuine accessories provides effective support for your sporting ambitions, no matter whether your equipment of choice includes skis, snowboards or bikes. And there are also the incenio light-alloy wheels for anyone wanting to add a few more decorative touches. Plus there is a whole host of other accessories with which you can signal your love of variety, and which also show that only genuine accessories from Mercedes-Benz are a perfect fit for a Mercedes-Benz.

To find out more, please see our Accessories brochure or consult your Mercedes-Benz dealer who will be pleased to advise you.

More scope for personal wishes: “Furud” incenio light-alloy wheels with 275/50 R 20 tyres, side protection bars with steps, basic carrier bars and ski and snowboard rack



The boot tub (deep) helps to keep the load compartment clean. Made from food-safe material



The practical wire mesh partition in black consists of three combinable steel grilles which serve as dividers and protect the passenger compartment

Every stitch a masterpiece

The designo range

The uniqueness of the designo range reflects the unique quality of the resources used to create it. The finest materials are selected with great care and handcrafted to form exclusive wood trim and sumptuous upholstery. You feel designo every time you touch a seam, you recognise it when you see the perfectly finished surfaces and you smell it in the rich aroma of the fine leather.







A touch of finesse

The designo details

The designo appointments make it easy for you to turn your individual wishes into reality. They begin, of course, with the large range of colours offered. All four leather colours have one thing in common: character. The high-grade designo leather sports seats are available in designo black, designo cashmere beige, designo porcelain and designo light brown.

The seats feature a special design with six-section longitudinal piping and a matt chromed designo badge. The door centre panels with designo-specific stitching and the armrest between the front seats are covered with designo leather in the chosen colour. In addition, the door armrests and the grab handles on the doors and the centre console are trimmed with designo black leather.

The trim that goes with the designo appointments is available in designo brown poplar wood or designo umber maple grain wood. High-quality designo velour floor mats with black designo leather edging and a metal designo badge round off the designo appointments. Further designo appointments and information are available at www.mercedes-benz.com/designo



The exclusive leather dashboard



designo stands for carefully chosen materials



Anyone opting for a Mercedes buys far more than just a car

Mercedes-Benz Museum. 125 years of automotive history in one place – this is what awaits you at the Mercedes-Benz Museum in Stuttgart. Experience the unique excitement, and embark upon a thrilling journey through time. Housed inside an architecturally impressive building, over 1500 exhibits on nine levels give you an insight into the unique tradition and powers of innovation of the Mercedes-Benz brand. See the world's first two automobiles in the shape of the Benz Patent-Motorwagen (motor car) and the Daimler motorised carriage – both from the year 1886. Two linked circuits take you from the beginnings of the automobile, past a series of unforgettable classics, through more than 100 years of motor racing history and, finally, on to a glimpse of what the future holds – in an area covering a total of 16,500 square metres. Enjoy the unique brand experience. We look forward to your visit. Further details can be found at www.mercedes-benz-classic.com/museum

MercedesCard. The card is your ticket to the Mercedes-Benz experience: four times a year, we will send you exciting details of a selected range of events and services, which we have put together exclusively for you. Then there is the Mercedes Magazine with its fascinating reports and articles. But the MercedesCard also has many other uses: as a VISA credit card, it is an internationally accepted means of payment. Plus it offers further benefits to provide you with peace of mind, such as insurance packages. You can also gain free entry to the Mercedes-Benz Museum simply by showing your VISA MercedesCard. Further details can be found at www.mercedes-benz.de/mercedescard¹

Mercedes-Benz Financial Services. Mercedes-Benz stands for quality, innovation and safety – and the same applies to Mercedes-Benz Financial Services. Our innovative leasing and financing products are tailored to your financial needs and means, making it easy for you to secure the keys to your dream car. Once you are on the road, our insurance products offer you just the right level of protection on every trip. Finally, our service products ensure that your car is always in tip-top condition whilst keeping costs transparent and easily manageable. For a detailed quotation, please contact your Mercedes-Benz dealer, who will be glad to go through the latest financial offers and terms together with you.

¹ Information about the MercedesCard in Austria and Switzerland can be found on the Mercedes-Benz websites for these countries



Mercedes-Benz mobility. Your new car comes with the assurance of carefree driving, but if you should ever need help Mercedes-Benz Service24h is there for you. Just call the free-phone service hotline on 00800 1 777 7777². The newly integrated telematics service Mercedes-Benz Contact³ is even more customer-friendly: a touch of a button is all it takes to contact the Mercedes-Benz customer centre. If you wish, the relevant vehicle and position-related data can be transmitted at the same time, ensuring the shortest possible reaction time and rapid assistance. Also standard with your new car at no extra charge is the Mercedes-Benz Mobilo⁴ mobility package. Whether you have lost your key, have had a breakdown which cannot be repaired immediately or if the vehicle is damaged due to an accident or vandalism, Mobilo ensures that you still reach your destination – anywhere in Europe. Whatever your problem, one thing is certain: you will soon be able to resume your journey.

Service packages. Vehicle-specific services allow you to put together an individual package for your Mercedes, including long-term protection against unforeseeable repair costs and high-quality servicing with genuine Mercedes-Benz parts. You can also count on the extensive network of Mercedes-Benz workshops, where you will receive the usual high standard of service for your Mercedes at a predictable, fixed price. Please ask your Mercedes-Benz dealer for further details.

Test drive. The unique feeling of driving a Mercedes cannot be put into words. Which is why we'd like to invite you to take a test drive. Simply visit www.mercedes-benz.com to locate the nearest Mercedes-Benz dealer in your country or region. We look forward to seeing you.

Interactive Owner's Manual. The website also offers an interactive tour, enabling you to take a closer look at your desired model. These informative clips are the ideal way to acquaint yourself with your dream car. You can view key functions in detail, gain an insight into the car's inner workings or look at the benefits of each model. For further details, go to: www.mercedes-benz.de/owners-manual

Mobile internet. Now you can access the entire world of Mercedes-Benz from your mobile phone. As well as an overview of all the passenger car models, there are insights into the entire brand world along with a wealth of entertainment offers and direct links to our range of services at www.mercedes.mobi

² Mobile phone rates vary according to service provider

³ Only in conjunction with a factory-fitted radio and switched-on mobile phone. For the cost of a call to the landline network

⁴ When the warranty has expired Mobilo can be extended by another year for a maximum of 30 years, provided that regular maintenance is carried out by your Mercedes-Benz service partner

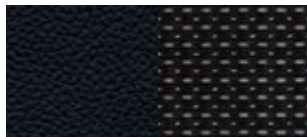
ARTICO MAN-MADE LEATHER/
ASPEN FABRIC¹

001 black

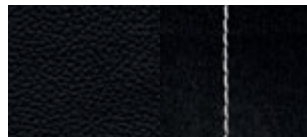
ARTICO MAN-MADE LEATHER/
ALCANTARA® FABRIC²

911 black



918 alpaca grey

¹ Standard for ML 300 CDI BlueEFFICIENCY, ML 350 CDI, ML 350 BlueTEC and ML 350

² Optional extra, only in conjunction with Interior Sports package

³ Optional extra, standard for ML 500

⁴ Optional extra

ARTICO MAN-MADE LEATHER³

151 black



154 cashmere beige

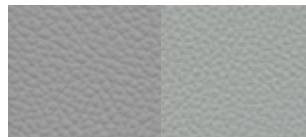

158 alpaca grey

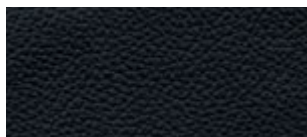
LEATHER⁴

221 black



224 cashmere beige



228 alpaca grey

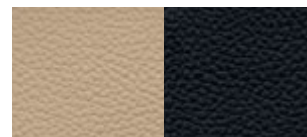

264 cashmere beige/black

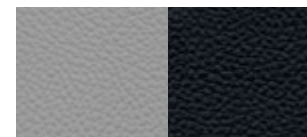

268 alpaca grey/black

designo LEATHER



X11 black

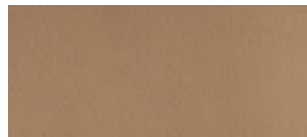

X25 cashmere beige

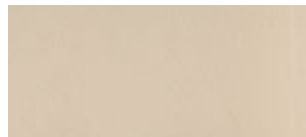

X27 porcelain

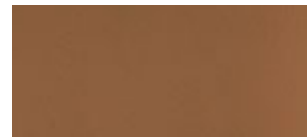

X35 light brown

TRIM

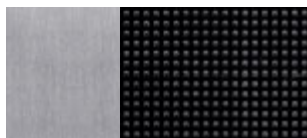
739 longitudinal-grain aluminium,
light/blackH04 high-gloss brown bird's-eye
poplar wood⁴729 high-gloss anthracite poplar
wood with chrome trim⁴731 high-gloss brown burr walnut
wood with chrome trim⁴

	ML 300 CDI 4MATIC BlueEFFICIENCY	ML 350 CDI 4MATIC	ML 350 BlueTEC 4MATIC	ML 350 4MATIC	ML 500 4MATIC
OFF-ROAD PERFORMANCE					
Fording depth, standard susp./ Off-Road Pro Eng. package (mm)	500/600	500/600	500/600	500/600	500/600
Angle of approach/departure¹ (degrees)					
standard suspension	26°/26°	27°/26°	27°/26°	27°/26°	25°-31°/24°-29°
with Off-Road Pro Engineering package	33°/30°	33°/30°	33°/30°	33°/30°	25°-33°/24°-30°
Minimum ground clearance, front/rear¹ (mm)					
standard suspension	201/214	210/223	210/223	210/223	186-261/194-269 ²
with Off-Road Pro Engineering package ²	186-291/194-299	186-291/194-299	186-291/194-299	186-291/194-299	186-291/194-299
Gradient climbing ability^{1,3} (%)	100	100	100	100	100
Maximum breakover angle (degrees)					
standard suspension	16°	17°	17°	17°	14°-21°
with Off-Road Pro Engineering package ²	14°-23°	14°-23°	14°-23°	14°-23°	14°-23°
Low-range ratio⁴	2.93 : 1	2.93 : 1	2.93 : 1	2.93 : 1	2.93 : 1
Power distribution of permanent all-wheel drive	50 : 50	50 : 50	50 : 50	50 : 50	50 : 50

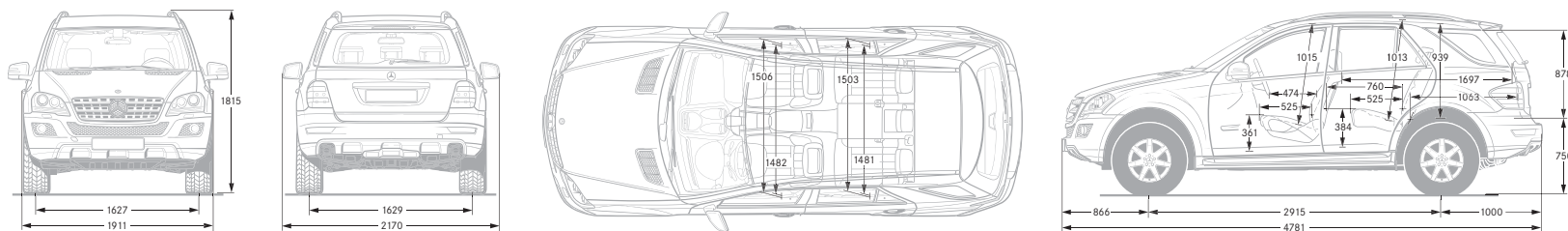

All figures in mm. The dimensions shown are mean values and apply to unladen vehicles fitted with the standard steel-spring suspension package

¹ Figures in accordance with Directive 70/156/EEC, version 2000/40/EC

² Basic setting front/rear (mm) : 201/209

³ Minimum 60% (= 31°), depending on surface and traction levels

⁴ Only with Off-Road Pro Engineering package

	ML 300 CDI 4MATIC BlueEFFICIENCY	ML 350 CDI 4MATIC	ML 350 BlueTEC 4MATIC	ML 350 4MATIC	ML 500 4MATIC
No. of cylinders/arrangement	6/V	6/V	6/V	6/V	8/V
Total displacement (cc)	2987	2987	2987	3498	5461
Rated output ¹ (kW at rpm)	150/4000	170/3800	155/3400	200/6000	285/6000
Rated torque ¹ (Nm at rpm)	500/1400–2400	540/1600–2400	540/1600–2400	350/2400–5000	530/2800–4800
Top speed, approx. (km/h)	210 ²	220	210 ²	225	250 ²
Acceleration 0–100 km/h (s)	8.3	7.6	8.7	8.4	5.8
Tyre size	235/65 R 17	235/65 R 17	235/65 R 17	235/65 R 17	255/50 R 19
Fuel	Diesel	Diesel	Diesel	Premium petrol	Premium petrol
Fuel consumption ³ (l/100 km)					
urban	10.6–11.3	11.1–11.6	11.9–12.2	15.2–15.7	18.0
extra-urban	7.1–7.8	7.6–8.1	6.7–7.2	9.2–9.9	10.2
combined	8.4–9.1	8.9–9.4	8.7–9.1	11.4–12.0	13.1
CO ₂ emissions ³ (g/km)/emissions standard	224–240/Euro 5	235–246/Euro 5	231–239/Euro 6	266–281/Euro 5	304/Euro 5
Tank capacity (l)/incl. approx. reserve	95/13	95/13	95/13	95/13	95/13
Turning circle diameter (m)	11.6	11.6	11.6	11.6	11.6
Kerb weight ⁴ (kg)	2185	2185	2185	2135	2185
Permissible GVW (kg)	2910	2910	2910	2830	2830
Permissible towing capacity ⁵ (kg)					
braked/unbraked	3500/750	3500/750	3500/750	3500/750	3500/750
Load capacity (l)					
max. behind 2 nd row of seats	813	813	813	813	813
max. behind 1 st row of seats	2050	2050	2050	2050	2050

¹ Figures in accordance with Directive 80/1269/EEC in the currently applicable version ² Electronically governed ³ The figures shown were obtained in accordance with the prescribed measuring process (Directive 80/1268/EEC in the currently applicable version). The figures are not based on an individual vehicle and do not constitute part of the product offer; they are provided solely for purposes of comparison between different vehicle models. For further information on the official fuel consumption and official specific CO₂ emissions of new passenger cars, please refer to the "Guide to the fuel consumption and CO₂ emissions of new passenger cars", which is available free of charge at all points of sale and from Deutsche Automobil Treuhand GmbH

⁴ Figures in accordance with Directive 92/21/EC, version 95/48/EC (kerb weight with fuel tank 90% full, driver, 68 kg, and luggage, 7 kg) for standard-specification vehicles. Optional extras and accessories will generally increase this figure and reduce the payload capacity accordingly ⁵ Including drawbar load of 140 kg

NON-METALLIC PAINTS (standard)



040 black



650 calcite white

SPECIAL METALLIC PAINTS (optional)



349 lazurite blue



474 peridot brown

METALLIC PAINTS (optional)



197 obsidian black



359 tanzanite blue



755 tenorite grey



775 iridium silver

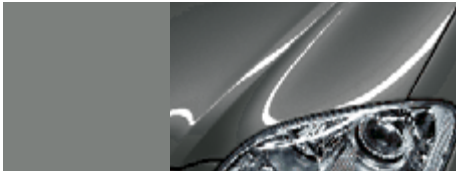

792 palladium silver



799 diamond white BRIGHT

Take-back of end-of-life Vehicles. Coming full circle. At the end of its long life, you can return your M-Class to us for environment-friendly disposal in accordance with the EU End-Of-Life Vehicle Directive¹. But that day lies a long way off.

¹ Applies in accordance with national regulations to vehicles up to 3.5 tonnes permissible gross weight. Mercedes-Benz passenger cars have met the statutory regulations governing the suitability of their design for reuse and recycling for a number of years now. A network of vehicle take-back depots and dismantlers has been established which will process your vehicle in an environment-friendly manner. The ways in which both vehicles and parts can be recovered are subject to ongoing development and improvement. Consequently, the M-Class will be able to comply with any future increases in the recycling quota within the stipulated time limits. For further information please visit www.mercedes-benz.com

Please note: Changes may have been made to the product since this brochure went to press (29.07.2010). The manufacturer reserves the right to make changes to the design, form, colour and specification during the delivery period, provided these changes, while taking into account the interests of the vendor, can be deemed reasonable with respect to the purchaser. Where the vendor or the manufacturer uses symbols or numbers to describe an order or the subject of an order, no rights may be derived solely from these. The illustrations may show accessories and items of optional equipment which are not part of standard specification. Colours may differ slightly from those shown, owing to the limitations of the printing process. This brochure provides a general indication of the range of models, features, optional extras and/or colours available in various countries. Some of the models, features, optional extras and/or colours may not be available in your country, or may only be available in a different specification. Additionally some models, features, optional extras and/or colours may only be available in combination with others. For current and more specific information in relation to the range of models, features, optional extras and/or colours available in your country, and their pricing, you should contact your nearest authorised Mercedes-Benz Passenger Car Dealer. www.mercedes-benz.com