



This Brochure is prepared by Daimler AG and it predominantly reflects the capabilities and performance of vehicles sold in Europe. Some characteristics, capabilities, performance features and optional extras (e.g. towing systems) may not be available or may not apply in Australia or under Australian conditions. The information in this Brochure is therefore indicative, illustrative and provided only for guidance and should not be relied on. To obtain current and accurate information on a vehicle and any options applicable to Australia, contact your local authorised Mercedes-Benz dealer.

Mercedes-Benz



The SLK-Class

Mercedes-Benz

From the Mercedes-Benz dream factory

# Contents

<b>The SLK</b>	<b>4</b>	<b>My SLK</b>	<b>44</b>
<b>Agility</b>	<b>6</b>	<b>Equipment</b>	<b>46</b>
Exterior design	6	Sports package	46
Driving dynamics	14	Standard equipment	48
Vario-roof	16	Optional extras	50
BlueEFFICIENCY	18	Light-alloy wheels	52
Petrol engines	20	Audio and communication systems	54
Transmissions	24		
		<b>Genuine accessories</b>	<b>58</b>
<b>Safety</b>	<b>26</b>	<b>designo</b>	<b>60</b>
Active safety	26		
Passive safety	28		
		<b>Colours and materials</b>	<b>62</b>
<b>Comfort</b>	<b>30</b>	Paintwork	62
Interior design	30	Upholstery and trim	64
		Combination options	66
<b>COMAND APS</b>	<b>36</b>		
		<b>Technical data</b>	<b>68</b>
<b>AMG</b>	<b>38</b>	<b>Services</b>	<b>70</b>
SLK 55 AMG	38		
AMG Performance Studio	40		
AMG optional extras	42		

# Start measuring time a new way

Ever since Einstein we have known that neither time nor space are absolute dimensions. Time can drag by ever so slowly, for example when you are waiting for something much longed-for, whereas in moments of happiness it feels as if it literally flies by. Seen from this perspective, the SLK is something of a time machine. A roadster and at the same time a full-blooded coupé, created so you can experience each moment as intensely as possible. Come along for a little time travel and become part of this exciting car's success story.

The SLK





# From 0 to absolute fascination in 0.1 seconds flat

Exterior design

First impressions count, and are seldom reconsidered. One glance is all it takes for the brain to make a split-second, instinctive decision. Now, if it's fascination at first sight the moment you see the SLK, this could be due to its classic roadster proportions with short overhangs and a dynamically styled front section, together

with the sporty looks of the light-alloy wheels. Whatever the reason, one thing is certain: a lot has been said and written about designing cars. And a lot of verbose expositions have been made about this or that formal idiom, or these or those flowing lines. But in all honesty - one look at the SLK says it all.







20:42

S OT 9481





# As time goes by, fascination turns into a lasting captivation

Exterior design

Its very design makes you want to set it in motion. With its beguiling looks, the SLK forms a thoroughly impressive package from tip to toe. It goes without saying, of course, that the tail end of the SLK is every bit as eye-catching as its striking front, courtesy of distinctive tailpipes, the bumper with a hint of a diffuser at the bottom, as well as the dark-tinted tail lights. Consequently, the instant you set eyes on the SLK, you will feel an urge... to get behind the wheel.













# Discover the joy of the perpetual perfect moment

## Agility

You are enjoying the exhilarating acceleration and the incomparable sensation of open-top motoring: there are moments when absolutely everything seems perfect. Those are precisely the occasions for which we built the SLK. Then, time somehow seems to go faster, so that even driving great distances becomes an enthralling experience because of its intensity. Effortlessly superior agility, dynamism you can feel, plus remarkably precise handling with the optional Direct-Steer system all allow you to experience sportiness in an entirely new way aboard this timelessly beautiful roadster. Every single day, should you wish.

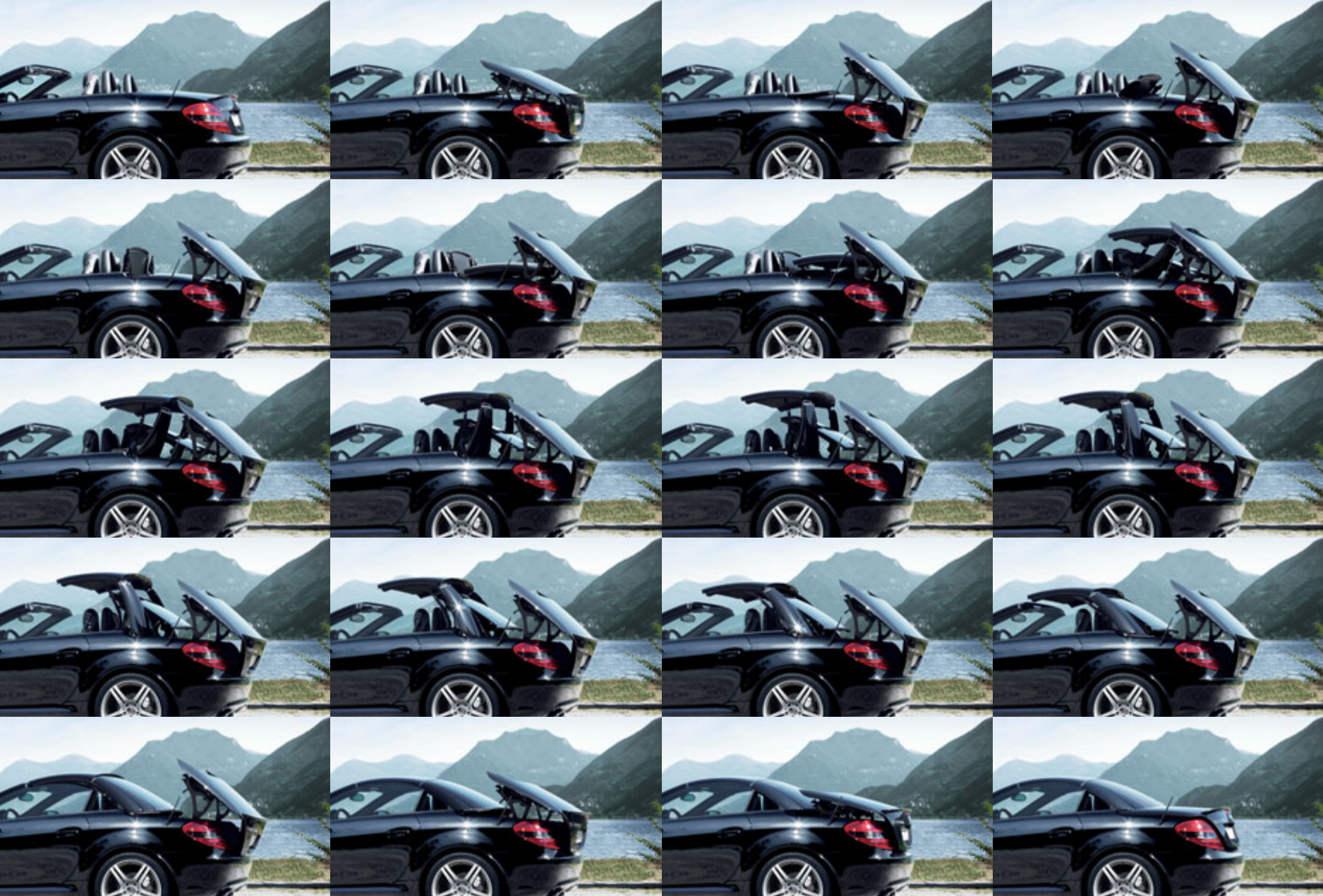

Infinite headroom, instantly! With the vario-roof, which made its first ever appearance on an SLK. Pressing a button is all it takes for the vario-roof to disappear into the boot in 22 seconds. In the closed position, you will benefit from the pleasant noise insulation it provides, the reassuring feeling of having a solid roof over your head, and 300 litres of luggage capacity. With the roof open, there is even room for 208 litres, thanks to the vario-roof's elaborate folding technology.

In order to prevent irritating airflow turbulence in the neck region from diluting the roadster sensation when driving with the roof down, you have a choice of two optional draught-stop systems.

And if you are looking to drive with the roof open even when the warm summer days are a distant memory, you will be thrilled with the AIRSCARF neck-level heating system developed by Mercedes-Benz. Here, air flowing out of the head restraint provides warmth in the head and neck region, enabling you to enjoy the roadster season all year long, if you so desire.



## BlueEFFICIENCY - fast forward to tomorrow

We do not pay lip service to protection of the environment. It's a matter close to our hearts. By the end of 2010, we will be able to offer you 85 models with BlueEFFICIENCY technologies, all of which place far less of a burden on the environment. Our BlueEFFICIENCY concept comprises innovations for efficient mobility as well as optimised processes all the way along the value chain.

**The BlueEFFICIENCY measures – the Mercedes-Benz efficiency package.** The BlueEFFICIENCY measures are comprehensive vehicle optimisations designed to ease the burden on the environment. Each model combines the most efficient engine with optimum aerodynamic and energy-management measures, including the ECO start/stop function, which is being made available for an increasing number of models. Our new V6 and V8 petrol engines in the S-Class and CL-Class, for example, reduce fuel consumption by up to 20% yet have a much higher power output.

**BlueTEC – the clean diesel.** A modular emission-control system makes BlueTEC an exceptionally clean diesel technology. As well as removing 95% of the particulate, it also reduces nitrogen oxides by up to 90%. All that remains is water and harmless nitrogen.

**HYBRID – the intelligent combination of petrol and electric drive.** During braking, the electric motor supplies the battery with the recuperated kinetic energy. This energy is then available when needed. What's more, the ECU shuts off the petrol engine when the speed falls below 15 km/h. In this way, a HYBRID can reduce fuel consumption by up to 20%.

**BlueTEC HYBRID – clean diesel combined with electric drive.** From 2011, BlueTEC HYBRID will marry the benefits of the HYBRID with those of BlueTEC: during braking, the kinetic energy is converted into electrical energy, which can be re-used when required. At the same time, the BlueTEC technology cleans the exhaust gases and removes many of the pollutants. All of which makes the economical diesel powerplant even more efficient and clean.



The BlueEFFICIENCY measures bring about a substantial reduction in fuel consumption and CO<sub>2</sub> emissions



**Innovative drive systems that break new ground: E-CELL and F-CELL.** We have developed two locally emission-free drive systems that will be produced on a small scale and delivered to customers around the world starting in 2010. The B-Class F-CELL uses hydrogen to produce power for the electric motor, while the A-Class E-CELL draws its energy from a battery alone.

But that is not all: under the banner “Design for Environment”, we also look at a vehicle’s entire lifecycle and work hard to preserve the environment from the planning stage right through to recycling. In addition, we are heavily involved in the development of alternative fuels and carry out research in the field of bionics. Further information about our comprehensive measures can be found at:  
[www.mercedes-benz.com/blueefficiency](http://www.mercedes-benz.com/blueefficiency)



**HYBRID technology** reduces fuel consumption by up to 20%



The B-Class F-CELL, with its locally emission-free electric drive system, receives its energy from a fuel cell

# High time for a most powerful argument

## The SLK 350 sports engine

More than enough power for getting away from it all. The SLK offers you the widest choice of engine outputs in its class. The engines all have one thing in common: they turn every drive in your SLK into a most moving experience, and, thanks to the vehicle's generously-sized 70-litre fuel tank and the resulting range, you can revel in it at great length.

You might opt for the spirited SLK 350 sports engine, for instance. This 6-cylinder unit just

loves to accelerate the car, with a formidable 224 kW at its disposal, and truly makes its mark with a high-revving design that permits engine speeds of up to 7200 rpm. What's more, it delivers a thrilling sound that truly gets under your skin over the entire rev band, as well as power galore for tasting pure driving bliss. One final thing worth mentioning is that, despite the tremendous power output, our engineers have actually succeeded in cutting both the engine's fuel consumption and its pollutant emissions.

SLK 350 sports engine

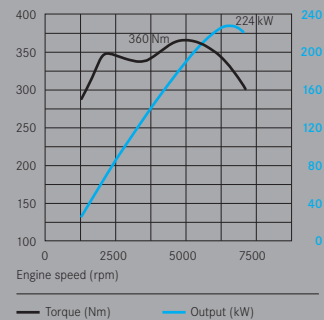







# A temperament to suit all tastes

The SLK 200 KOMPRESSOR and the SLK 300

Delivering an output of 135 kW, the SLK 200 KOMPRESSOR propels the SLK along in agile, dynamic fashion, while delighting with its understated yet resonant sound. The SLK 300 promises an even sportier drive, mustering up as it does 170 kW from its displacement of 2996 cc. And thanks to its uniform power delivery and impressive refinement, the SLK 300 succeeds in fusing motoring comfort with motoring pleasure.

To continue as the leaders of tomorrow, it is vital to think in terms of sustainability today. That's why we have significantly reduced the CO<sub>2</sub> emissions and fuel consumption of the engines detailed here, in spite of their impressive output figures. Please refer to page 68 for more information on fuel consumption and CO<sub>2</sub> emissions.

SLK 200 KOMPRESSOR

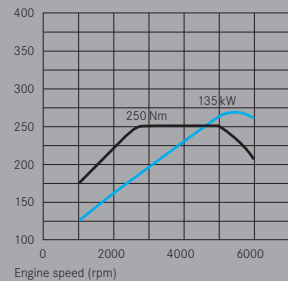

SLK 300

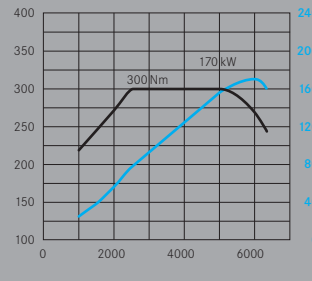

— Torque (Nm) — Output (kW)



# As precise as a Swiss watch – and saves fuel too

## The transmissions

The SLK stands for responsiveness and agility of the highest degree. And if you move fast, you must be able to shift fast, too. That's why the power of the various engines is transferred by transmissions which are precisely attuned to the temperament of each model. You can choose between the standard 6-speed manual transmission and an optional 5-speed automatic transmission for the SLK 200 KOMPRESSOR. For those who prefer one of the 6-cylinder engines, 7G-TRONIC, the 7-speed automatic transmission, is available as an option. In the SLK 55 AMG, this transmission is standard. The

optional 7G-TRONIC Sport with steering-wheel gearshift paddles ensures even swifter gearshifts. These steering-wheel gearshift paddles can be ordered as optional equipment for all automatic transmissions, and are included as standard on the SLK 55 AMG.

With its seven speeds, the 7G-TRONIC automatic transmission adapts marvellously to every driving situation. The seven ratios ensure that the jumps in rev speed from one gear to the next are small, resulting in smoother gearshifts and a lower average rev speed level. In addition, it offers the possibility of multiple downshifts for extra-fast acceleration at any time



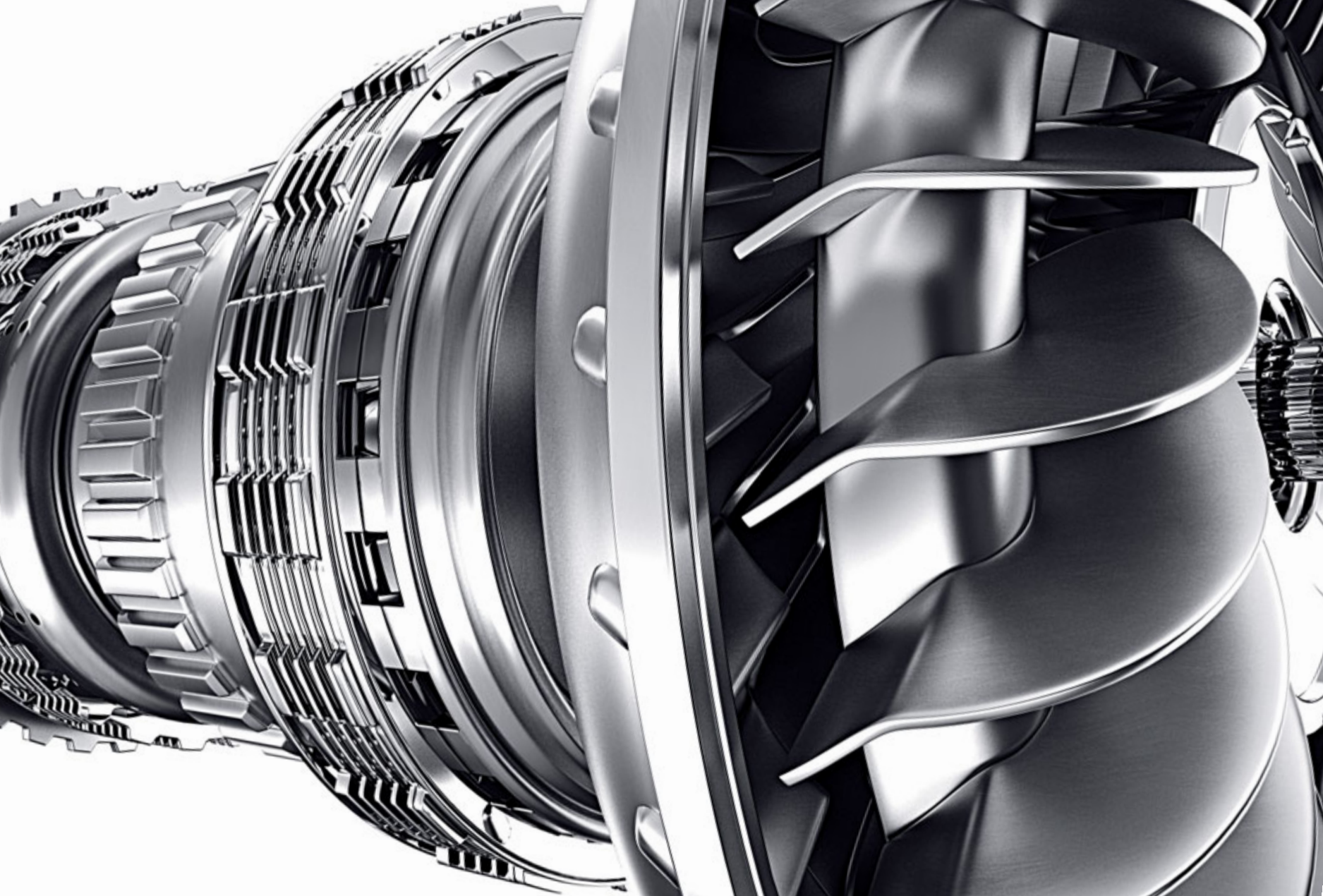





## When your safety is at stake, the SLK takes action in an instant

### Active safety

To prevent accidents from happening in the first place, a high level of active safety is built-in for undiluted driving pleasure. Your SLK is, of course, equipped with ESP® and BAS as standard. If the vehicle is at risk of entering a skid, ESP® helps to defuse the situation through targeted

interventions in the braking and engine management systems. Meanwhile, the electronic Brake Assist system detects emergency braking from the speed with which you press the brake pedal, whereupon it instantly builds up maximum braking power.

# Years of research shows its worth in a split second

## Passive safety

What might be awaiting you around the next bend? There may indeed be questions for which no safety system yet has the answer, but in practically all other situations you can rely on the SLK's intelligent safety concept. Should the worst come to the worst, you will be protected by belt tensioners as well as adaptive driver's and passenger's airbags. The SLK is equipped with head/thorax sidebags too. These are located in the outside edges of the seat backrests, and together with the roll-over sensor, they afford

the best possible occupant protection in the event of a lateral collision or of the vehicle overturning. All these systems have been integrated in an extremely torsionally-rigid passenger safety cell which, in combination with the roll-over bars built into the vehicle body, ensures you always keep on the safe side in spite of all the vehicle's openness. Added to this is the fact that the robust steel construction of the vario-roof when closed offers even greater safety.



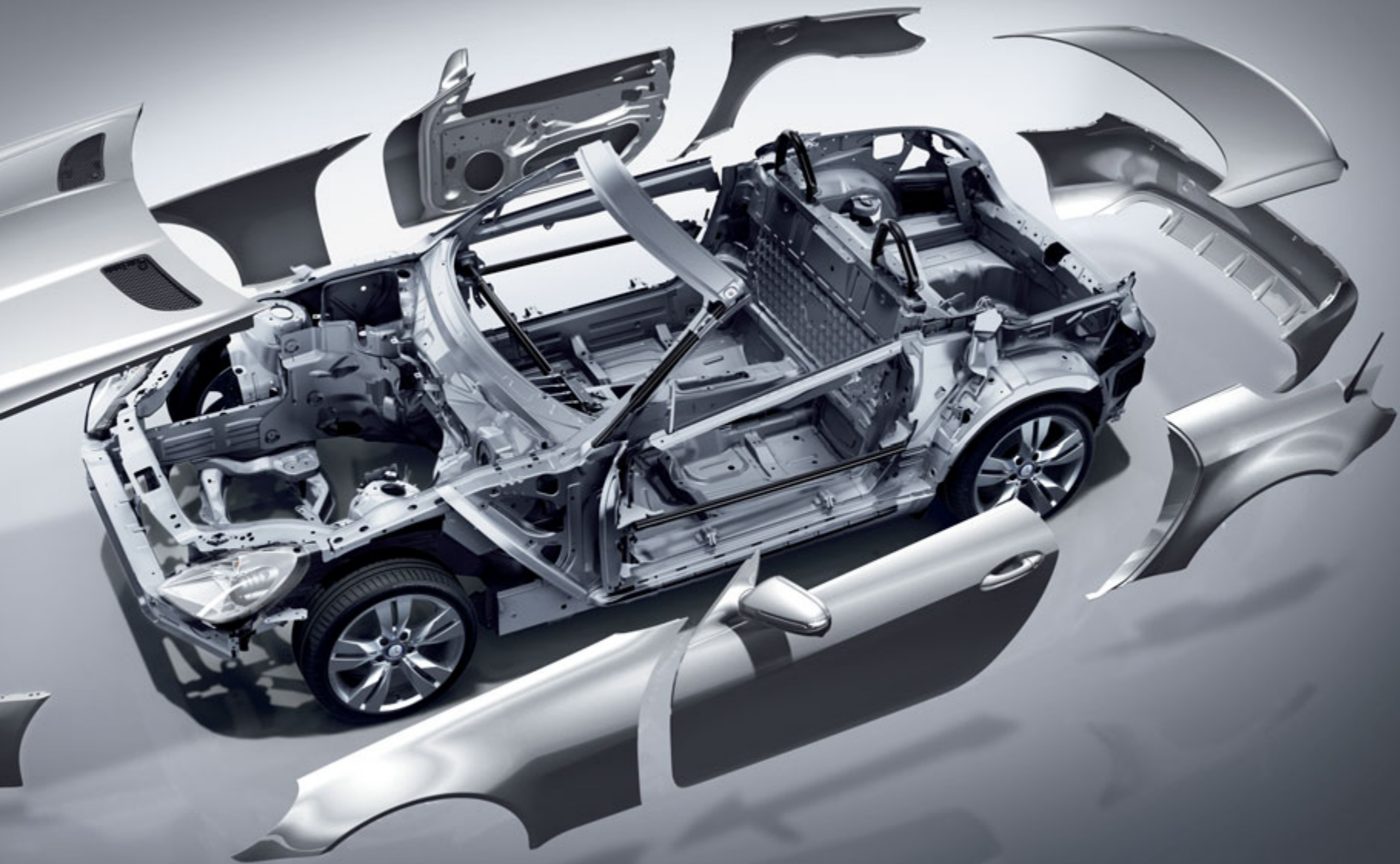

# Ergonomics can either be explained at length, or felt at once

## Interior design

If you want to have fun, you have no time to waste. That's why it is good that not only are all the controls and displays crafted with the highest



The 3-spoke sports steering wheel trimmed in nappa leather features practical multifunction buttons as standard

workmanship, but are also placed just where you would intuitively expect them to be. Because that is the only way to have the reassuring feeling of being in direct control of the vehicle: a control so powerful and intense that it makes you feel at one with the vehicle's technology. The sports steering wheel trimmed in supple nappa leather with standard-fit multifunction buttons feels good in your hands, while the interior can be given a particularly refined air by opting for the exclusive wood trims in a choice of light burr walnut and black ash. Positioned directly in your field of vision to keep you constantly informed of all key data is the instrument cluster, which stands out for its understated good looks with red needles, elegant dial bezels in a 3D look, plus tubes with chrome surrounds.



USE APPROPRIATE TYRES  
FOR YOUR VEHICLE  
FOR MORE INFORMATION  
CONTACT YOUR LOCAL  
VOLVO DEALER



FM 4

↑  
SWR3  
↓

+23.0 °C



# Open for spontaneous decisions

## Interior design

The interior of the SLK is the perfect place for enjoying yourself. Awaiting you here is a stylish symbiosis of out-and-out sportiness on the one hand and, on the other, a degree of space and comfort which is otherwise virtually unheard of in this segment. The result is a clear enhancement of motoring pleasure. The optional leather appointments allow you to give your SLK an even more exclusive look: you can choose from leather in black, alpaca grey, orient beige or gullwing

red. And anyone looking for an even greater air of refinement can opt for the luxurious nappa leather appointments: here, the seats are upholstered in finest nappa leather in either black or natural beige, and even the centre armrest is trimmed in soft black nappa leather, complete with elegant topstitching. Whatever you decide on, you can be sure of exceptional build and material quality. The SLK is, after all, one thing above all else: a Mercedes.





Mercedes-Benz



# Sport has seldom been so relaxing

## Driving comfort

This is just how comfortable sporty motoring can be. You will start to appreciate the excellent lateral support of the dynamically contoured seats with their magnesium frame on your very first outing. Then there is the spontaneous, agile handling of the optional Direct-Steer system with variable servo assistance, which is unrivalled in this segment and positively invites you to power through bends in the road. Thanks to the outstanding suspension tuning, even longer journeys are nothing less than an absolute delight. You also have the option of the innovative AIRSCARF neck-level heating system: by delivering pleasantly warm air from the head restraints it allows you to extend the cabriolet season at the touch of a button. And to maintain a refreshing climate when the roof is up, too, there is either the air

conditioning system that comes as standard in the SLK 300, SLK 350 and SLK 55 AMG, or the optional THERMOTRONIC luxury automatic climate control featuring automatic regulation of the air distribution, plus solar and air quality sensors.



The innovative AIRSCARF neck-level heating (optional) can keep your head and neck snug and warm



RADIO

DISC

NAVI

TEL



SYS



ON

11:47

TA

T-Mobile D



Navi Audio Tel Video System

1. SWR1 BW

• 101.3 MHz

3

**SWR3**

2. SWR2 BW

4. 102.3 MHz

Radio

Speicher

FM

Klang

1

2

3

QW

ABC

DEF

4

5

6

GHI

JKL

MNO

7

8

9

PGRS

TUV

WXYZ

\*

0

#



C



# If you wish, your SLK can listen to your every word

## Ease of operation

At last! A car that understands you. This is because you have the option of the sophisticated COMAND APS multimedia system. The system's intuitive user guidance makes it more user-friendly than ever, despite its vast array of functions. The COMAND APS features a fast hard-disc navigation system including a 3D display, a MUSIC REGISTER for storing audio files, plus a high-resolution 16.5-cm colour display, to name but a few of the highlights. The entire system can be operated from an ergonomically positioned control pad. What's more, the SLK can also be ordered with the voice-operated control system LINGUATRONIC for operating the audio, telephone and navigation

systems. The system is already contained within the COMAND APS and can also be added to the optional Audio 50 APS, if you wish.



The multifunction buttons allow you to control many of the COMAND APS system's functions directly from the steering wheel

## AMG. Three letters – one clear statement

### The SLK 55 AMG

You can see it immediately just from the outside: this is as SLK as it gets. Because the SLK 55 AMG interprets the sporty, elegant look of the classic roadster more assertively and uncompromisingly than ever. And it lives up to this exterior promise in every way by delivering true sports car performance. Under the bonnet, an AMG V8 engine with a displacement of 5.5 litres generates



a breathtaking 265 kW and a maximum torque of 510 Nm. The SLK 55 AMG sprints from 0 to 100 km/h in 4.9 seconds. More than sufficient to press you with pleasant firmness back into the exclusive AMG nappa leather sports seats. The SLK 55 AMG is equipped as standard with the innovative AMG SPEEDSHIFT 7G-TRONIC, which permits extra-swift gear-shifting. The transmission can also be controlled by means of the steering-wheel gearshift paddles on the AMG sports steering wheel trimmed in nappa leather. Further highlights of the extensive high-performance specification of the SLK 55 AMG are the AMG sports suspension and the AMG multi-spoke light-alloy wheels in a high-sheen, titanium-grey-painted finish that are exclusive to this model.







D S LK 5505



# If the only sports that count for you are high-performance sports

## The AMG Performance Studio

For even more dynamic driving, there are exclusive optional extras available for the SLK 55 AMG from the AMG Performance Studio. Here, for instance, you can opt for the multi-piece twin-spoke AMG light-alloy wheels, an AMG performance suspension, as well as AMG carbon-fibre trim elements and the AMG performance steering wheel trimmed

in nappa leather, with its flattened lower section and smaller rim diameter. For ultimate motoring pleasure there is the highly attractive AMG Performance package, which comprises an AMG high-performance compound brake system in addition to the features mentioned above.



# Where would an athlete be without the right outfit?

The optional AMG bodystyling and AMG light-alloy wheels

If you don't want to go for the SLK 55 AMG right away, you still have the option of underlining the SLK's sportiness to striking effect with AMG bodystyling. This package, created by Mercedes-AMG and consisting of dynamic-looking AMG aprons at the front and rear as well as muscular side skirts, lends the SLK a particularly athletic look.

In addition, the AMG spoiler lip neatly rounds off the exterior design, at the same time enhancing downforce and thus handling stability. Optionally, all SLK models can be fitted with high-shine twin-spoke AMG light-alloy wheels, shod with 225/40 R 18 tyres at the front and 245/35 R 18 at the rear.









My SLK

# The most beautiful combination of sports and aesthetics

## The SLK with the Sports package

Sportiness lies in the nature of the SLK. And the optional SLK Sports package allows you to elicit this temperament to stunning effect. The extensive package includes headlamp linings in a matt grey finish, as well as 5-twin-spoke light-alloy wheels in titanium silver, which lend yet greater emphasis to the car's dynamic appearance.

The striking perforated brake discs at the front provide extra reserves of stopping power, while the AMG spoiler lip on the tail generates even greater downforce at the rear axle. A sports suspension is also fitted as standard, and steering-wheel gearshift paddles are also included for models with the optional automatic transmission.

Yet the Sports package can be admired equally as well from the interior. Here you will find a black roof liner, red seat belts (optionally available in black), plus red topstitching on the seats, armrest, steering wheel and gearshift lever. Attractive carbon-look trim and floor mats with red edging round off the interior concept of the Sports package in style.









The roll-over bars offer added protection if the worst comes to the worst



Cruise control makes for more relaxed motoring and can also reduce fuel consumption



The 3-spoke sports steering wheel trimmed in nappa leather with multifunction buttons as standard



The dark-tinted tail lights add to the sporty looks



Front fog lamps ensure clear visibility even in the most dreary weather



The shorter rod aerial is suitable for use in automatic car washes

**Standard equipment (selection)**

3-spoke sports steering wheel with multifunction buttons
6-speed manual transmission <sup>1</sup>
7-spoke light-alloy wheels with 205 / 55 R 16 tyres <sup>3</sup>
Adaptive front airbags and head/thorax bags (enlarged sidebag providing additional head protection) for driver and passenger
Air conditioning system including dust filter and activated charcoal filter <sup>2</sup>
Anti-lock braking system (ABS)
ASSYST PLUS service interval indicator with service computer
Audio 20 CD (with 12.7-cm colour display, MP3 capability and Bluetooth® hands-free system)
Automatic heating and ventilation system with dust filter and air recirculation button with convenience feature (automatic window closing)
Automatic seat occupancy sensor/child seat recognition system in passenger seat
Aux-in socket in glove compartment (omitted if optional media interface is ordered)
Belt tensioners with belt force limiters
Chrome-effect electronic key
Cruise control with SPEEDTRONIC variable speed limiter
Dark-tinted tail lights
Driver's and passenger seats height-adjustable
Electrohydraulic vario-roof, in vehicle colour, with heated rear windscreen
Electronic immobiliser with locking system and radio remote control

Electronic Stability Program ESP®
Folding armrest with compartment
Front fog lamps, one rear fog lamp
Indicator lamps in exterior mirrors
Interior lighting switch-on after accident
Power socket (12-V) in passenger footwell
Power steering and safety steering column
Remote boot lid release
Roll-over bars for driver and passenger
Short rod aerial, suitable for use in automatic car washes
Sports seats with magnesium backrest (folding) and integral head restraint
Steering column manually adjustable for height and reach
Stowage box on rear panel between seats
Stowage net in passenger footwell
Tinted windows all round
TIREFIT tyre sealant with electric pump
Trapezoidal-section tailpipes

<sup>1</sup> 7G-TRONIC automatic transmission standard for SLK 55 AMG<sup>2</sup> Available for SLK 200 KOMPRESSOR as an option<sup>3</sup> 5-spoke wheels for SLK 300, 5-twin-spoke wheels for SLK 350 sports engine, multi-spoke wheels for SLK 55 AMG



Thanks to the innovative AIRSCARF neck-level heating, you can enjoy open-top motoring without having to endure chilly temperatures in the head and neck region



The 3-spoke sports steering wheel is optionally available with shift paddles



The THERMOTRONIC luxury automatic climate control with automatic air distribution regulation



The electric seat adjustment control reproduces the shape of the seat, making it particularly user-friendly

Optional extras (selection)	SLK 200 K	SLK 300	SLK 350	SLK 55 AMG
4-way adjustable lumbar support for driver and passenger	●	●	●	–
5-speed automatic transmission	●	–	–	–
7G-TRONIC automatic transmission	–	●	●	○ <sup>2</sup>
AIRSCARF neck-level heating with fabric draught-stop	●	●	●	●
AMG bodystyling	●	●	●	○
Anti-Theft Protection package: anti-theft alarm system (ATA) with tow-away protection and interior monitoring	●	●	●	●
Audio 50 APS (as Audio 20 CD, with additional DVD arrow-based navigation and Junction View)	●	●	●	●
Battery with increased capacity	●	○	○	○
Bi-xenon headlamps with headlamp cleaning system, dynamic range adjustment and cornering light function	●	●	●	●
COMAND APS multimedia system for audio, navigation and telephone, incl. high-resolution 16.5-cm display, hard-disc navigation, MUSIC REGISTER and voice-operated control system LINGUATRONIC	●	●	●	●
Direct-Steer system with variable servo assistance	● <sup>3</sup>	●	●	○
Harman Kardon® Logic 7® surround sound system with Dolby 5.1/DTS	●	●	●	●
Heated windscreen washer system	●	●	●	●
Interior Light package	●	●	○	○
Lowered sports suspension	● <sup>3</sup>	●	●	–
Luxury automatic climate control THERMOTRONIC	●	●	●	●
Media interface, e.g. for MP3 player, iPod® and USB stick	●	●	●	●
Memory package: electrically adjustable seats with memory function as well as exterior mirrors with parking position, steering wheel that adjusts to aid entry/exit and crash-responsive exit aid	●	●	●	●
Mirror package: automatically dimming interior mirror and exterior mirror on driver's side as well as electrically folding exterior mirrors left and right	●	●	●	●
PARKTRONIC	●	●	●	●
Steering-wheel gearshift paddles <sup>1</sup>	●	●	●	○ <sup>2</sup>
Sports package	●	●	●	–

● Optional extra   ○ Standard equipment   – Not available

<sup>1</sup> Only in conjunction with automatic transmission

<sup>2</sup> AMG SPEEDSHIFT 7G-TRONIC with steering-wheel gearshift paddles standard for SLK 55 AMG

<sup>3</sup> Only in conjunction with mixed-size tyres

# Make your mark before you even touch the ignition key

The light-alloy wheels



7-spoke light-alloy wheel with 205 / 55 R 16 tyres  
(standard for SLK 200 KOMPRESSOR)



5-twin-spoke light-alloy wheel with 225 / 45 R 17 tyres at  
the front and 245 / 40 R 17 at the rear (standard for SLK 350,  
optional for SLK 200 KOMPRESSOR and SLK 300)



5-spoke light-alloy wheel with 205 / 55 R 16 tyres at the front  
and 225 / 50 R 16 at the rear (standard for SLK 300, optional for  
SLK 200 KOMPRESSOR)



5-twin-spoke light-alloy wheel with 225 / 45 R 17 tyres at  
the front and 245 / 40 R 17 at the rear (only in conjunction with  
sports suspension)

Light-alloy wheels are the calling card of any sporty car. Here you will find a wealth of suggestions for how to add a personal touch to your SLK.



10-spoke light-alloy wheel in "chrome shadow" high-gloss painted finish, with 225/45 R 17 tyres at the front and 245/40 R 17 at the rear



"Kikuchi" 5-twin-spoke light-alloy wheel with 225/45 R 17 tyres at the front and 245/40 R 17 at the rear



AMG multi-spoke light-alloy wheel in high-shine, titanium-grey-painted finish, with 225/40 R 18 tyres at the front and 245/35 R 18 at the rear (standard for SLK 55 AMG)



5-twin-spoke light-alloy wheel, titanium silver, with 225/40 R 18 tyres at the front and 245/35 R 18 at the rear (only in conjunction with Sports package)



AMG twin-spoke light-alloy wheel, high-shine finish, with 225/40 R 18 tyres at the front and 245/35 R 18 at the rear



AMG twin-spoke light-alloy wheel, multi-piece, with 225/40 R 18 tyres at the front and 245/35 R 18 at the rear (optional for SLK 55 AMG)

# Crystal clear and as impressive as the SLK itself

The Harman Kardon® Logic 7® surround sound system

If you would like to experience Dolby 5.1 digital sound in a class of its own, there is the option of the Harman Kardon® Logic 7® surround sound system with an output of 500 watts. This system has been specially developed for the SLK and

delivers pure listening pleasure for both driver and passenger through its eleven speakers. Regardless of whether the roof is up or down, or the recording is in stereo or 5.1: this is a high-end hi-fi system that is music to everyone's ears.

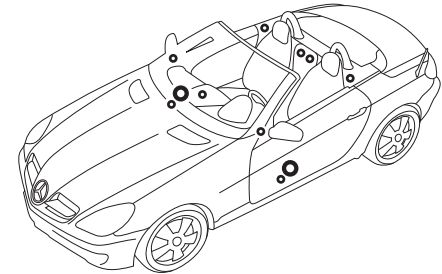

The clever arrangement of the speakers generates a sound field optimised specifically for the SLK, so you are able to enjoy a pristine sound at all times, even when driving with the roof down







AIRBAG

11:04 FM 92.2 MHz  
DIE NEUE SWR4 5  
SWR3  
DKL TUR 89.3 MHz  
Radio Speicher Klang



HILFEN SIE DEN NOTLEIDENDEN  
56

Welcome to today's communication society. There are a number of audio and communication systems to choose from for your SLK. A common feature of all the radios is the standard-fit Bluetooth® hands-free system. The range starts with the standard-fit Audio 20 CD featuring a 12.7-cm colour screen, built-in CD player with MP3 capability (can be upgraded to a built-in 6-disc CD changer) and an Aux-in connection in the glove compartment for connecting portable audio devices.

The Audio 50 APS supplements this with a DVD navigation system featuring an arrow-based display and Junction View. Anyone also opting for the built-in 6-disc DVD changer can enjoy the added luxury of the intuitive voice-operated control system LINGUATRONIC. This highly convenient means of control is included as standard with the COMAND APS, the innovative multimedia system with hard-disc navigation, including a 3D display and high-resolution 16.5-cm screens. In addition to this, COMAND APS comes with a MUSIC REGISTER, an SD memory card slot, plus a DVD video function.



The optional Audio 50 APS radio system can be upgraded to include a 6-disc DVD changer



The optional COMAND APS has a multimedia controller interface, allowing you to operate a host of functions with ease



# Ready for the finishing touches

Genuine accessories from Mercedes-Benz

Nothing impresses quite like the real thing. With genuine Mercedes-Benz accessories you can make even more out of your SLK. Take, for instance, the optional three-piece draught-stop with a transparent perspex panel and the two plastic-framed mesh sections. These practical



The perspex draught-stop reduces airflow turbulence

accessories help reduce airflow turbulence in the neck area and can be attached between the roll-over bars in next to no time. You can create further highlights too by adding spoiler lips for the front apron, for example, or the incenio “Korsunia” 5-triple-spoke light-alloy wheels



The cradles for mobile phones allow you to pair various phone models with the hands-free system

(pictured left). Exterior mirror housings and trim for the horizontal fins in the radiator grille and bumper – all in high-shine chrome – allow you to enhance the dynamic appearance of your SLK even further.



The practical “New Alustyle Luxury” ski and snowboard rack can carry up to six pairs of skis or four snowboards

# As individual as you are

The designo appointments

Custom-design your SLK as you please. Fine woods and exquisite leather upholstery – or combined leather and Alcantara® with striking double topstitching – give the interior an exclusive and highly individual flair.

Matching leather-covered trim and roll-over bars are available as an option. Further designo appointments and information can be found at [www.mercedes-benz.com/designo](http://www.mercedes-benz.com/designo)





The SLK paintwork puts the finishing touch to the carefully crafted Mercedes-Benz corrosion protection system, which includes zinc phosphating and electrophoretic dip priming stages for long-lasting protection. We also make very extensive use of eco-friendly water-based paints.

**NON-METALLIC PAINTS**

040 black



590 fire opal



650 calcite white

**METALLIC PAINTS**

197 obsidian black



230 indigolite blue



300 periclase green



SPECIAL PAINT FINISH



359 tanzanite blue

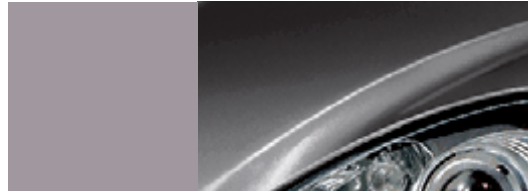

775 iridium silver



430 prehnite green



541 thulite red



792 palladium silver



755 tenorite grey

The seats of a Mercedes-Benz excel with a particularly high level of comfort, thanks to the special way in which the seat cushions are sprung and the use of separate foam elements for the centre panel of the seat cushion and the sides. The combination of the seat cushion spring set-up, which is precisely tuned to the vehicle, and the selection of the appropriate degree of cushion density results in exceptional springing and damping characteristics. To provide the perfect finishing touch, the seats are then upholstered in your own personal choice of fabric or leather.

## FABRIC

081 black<sup>1</sup>

## LEATHER

801 (851) black<sup>2</sup>808 (858) alpaca grey<sup>2</sup>815 (855) orient beige<sup>2</sup>817 (887) gullwing red<sup>2</sup>

<sup>1</sup> Standard specification

<sup>2</sup> Codes in brackets = standard nappa leather for SLK 55 AMG

<sup>3</sup> Further colours for designo two-tone leather are available to choose from

<sup>4</sup> Included in Sports package

<sup>5</sup> Further designo appointments and information can be found at [www.mercedes-benz.com/designo](http://www.mercedes-benz.com/designo)

## NAPPA LEATHER



861 black

designo<sup>5</sup> LEATHER, LEATHER / ALCANTARA<sup>®</sup>

X11 single-tone black

## TRIM

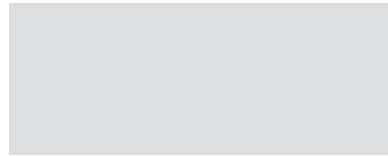
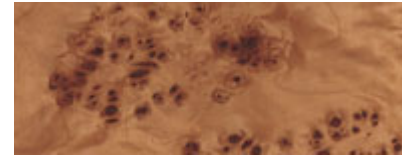
7H72 avus silver<sup>1</sup>designo<sup>3</sup> TRIM

W61 natural poplar



874 natural beige

883 two-tone classic red<sup>3</sup>

H12 light brown burr walnut wood, high-gloss



X20 single-tone black



736 black ash wood, high-gloss



X21 single-tone alpaca grey

7K79 carbon-look<sup>4</sup>

	FABRIC	LEATHER	NAPPA LEATHER
	black	black alpaca grey orient beige gullwing red	black natural beige
<b>NON-METALLIC PAINTS</b>			
black	●	● ● ● ●	● ●
fire opal	●	● ● ○ ●	● ○
calcite white	●	● ● ○ ●	● ●
<b>METALLIC PAINTS</b>			
obsidian black	●	● ● ● ●	● ●
indigolite blue	●	● ● ● △	● ○
periclase green	●	● ○ ● △	● ●
tanzanite blue	●	● ● ○ △	● ●
thulite red	●	● ● ● ○	● ○
tenorite grey	●	● ● ● ●	● ○
iridium silver	●	● ○ △ ●	● ●
palladium silver	●	● ● ○ ●	● △
<b>SPECIAL PAINT FINISH</b>			
prehnite green	●	● ○ ● △	● ○

● Possible    ○ Recommended    △ Not recommended

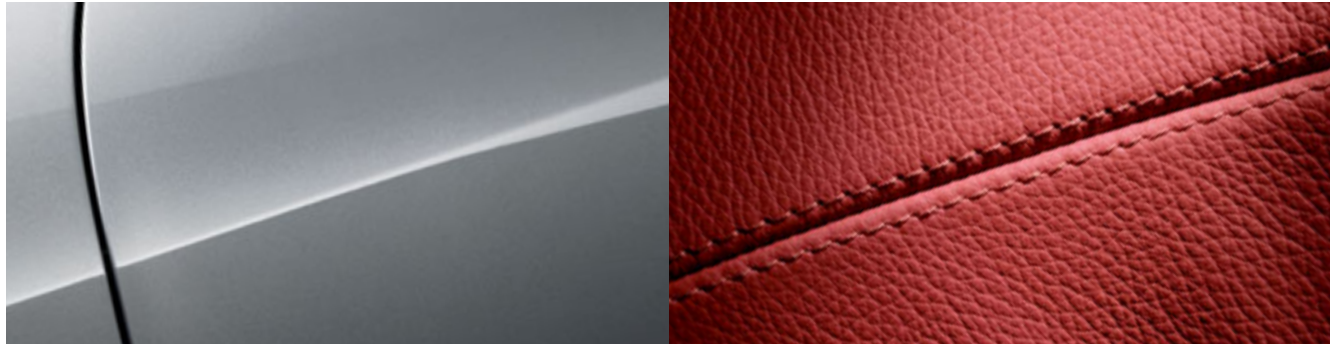

The combination of palladium silver metallic and gullwing red leather lends a particularly sporty flair



The combination of obsidian black metallic and black leather with red topstitching<sup>1</sup> also produces a most athletic look

<sup>1</sup> Available for the Sports package

	SLK 200 KOMPRESSOR	SLK 300	SLK 350 sports engine	SLK 55 AMG <sup>6</sup>
No. of cylinders/arrangement	4/in-line	6/V	6/V	8/V
Total displacement (cc)	1796	2996	3498	5439
Rated output <sup>1</sup> in kW at rpm	135/5500	170/6000	224/6500	265/5750
Rated torque <sup>1</sup> (Nm at rpm)	250/2800–5000	300/2500–5000	360/4900	510/4000
Compression	8.5	11.3	11.7	11.0
Acceleration from 0 to 100 km/h (s) (automatic transmission)	7.6 (7.9)	6.3 (6.2)	5.4 (5.4)	– (4.9)
Top speed, approx. (km/h) (automatic transmission)	236 (232)	250 <sup>2</sup> (250) <sup>2</sup>	250 <sup>2</sup> (250) <sup>2</sup>	– (250) <sup>2</sup>
Tyre size				
front	205/55 R 16 V	205/55 R 16 W	225/45 R 17 W	225/40 R 18 Y
rear	205/55 R 16 V	225/50 R 16 W	245/40 R 17 W	245/35 R 18 Y
Fuel	Premium petrol	Premium petrol	Premium petrol	Super Plus
Fuel consumption <sup>3</sup> (l/ 100 km)				
Urban/extra-urban/combined (automatic transmission)	11.0–11.2/5.7–6.0/7.7–7.9 (11.5–11.8/5.9–6.2/8.0–8.2)	13.9–14.1/6.8–7.0/9.5–9.7 (12.3–12.4/6.8–6.9/8.9–9.0)	14.5/7.0/9.7 (12.6/6.9/9.0)	– (17.7/8.8/12.0)
CO <sub>2</sub> emissions <sup>3</sup> (g/km), combined (automatic transmission)	182–188 (190–196)	220–225 (207–209)	227 (209)	– (288)
EU emissions standard	EU 5	EU 5	EU 5	EU 4
Tank capacity (l)/incl. approx. reserve	70/9	70/9	70/9	70/10
Boot capacity (l) <sup>4</sup>	300	300	300	300
Turning circle diameter (m)	10.51	10.51	10.51	10.51
Kerb weight <sup>5</sup> (kg) (automatic transmission)	1390 (1415)	1455 (1475)	1485 (1505)	– (1575)
Perm. GVW (kg)	1705	1770	1800	1850

<sup>1</sup> Figures according to Directive 80/1269/EEC in the currently applicable version

<sup>2</sup> Electronically governed

<sup>3</sup> The figures shown were obtained in accordance with the prescribed measuring process (Directive 80/1268/EEC in the currently applicable version). The figures are not based on an individual model and do not constitute part of the product offer; they are provided solely for purposes of comparison between different vehicle models

<sup>4</sup> With closed vario-roof

<sup>5</sup> Figures according to Directive 92/21/EC, version 95/48/EC (kerb weight with fuel tank 90% full, driver, 68 kg, and luggage, 7 kg) for standard-specification vehicles. Optional extras and accessories will generally increase this figure and reduce the payload capacity accordingly

<sup>6</sup> Only available with automatic transmission

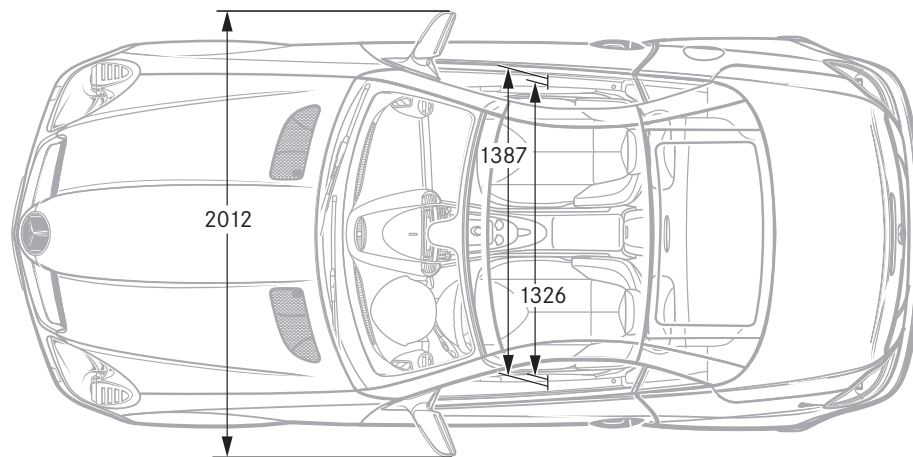
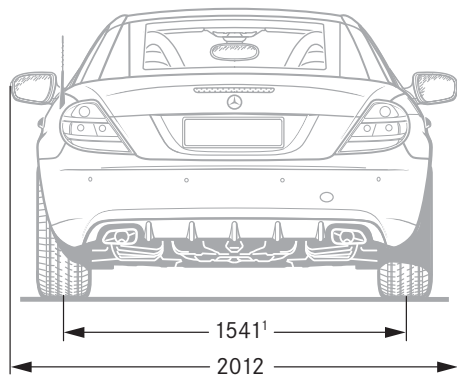
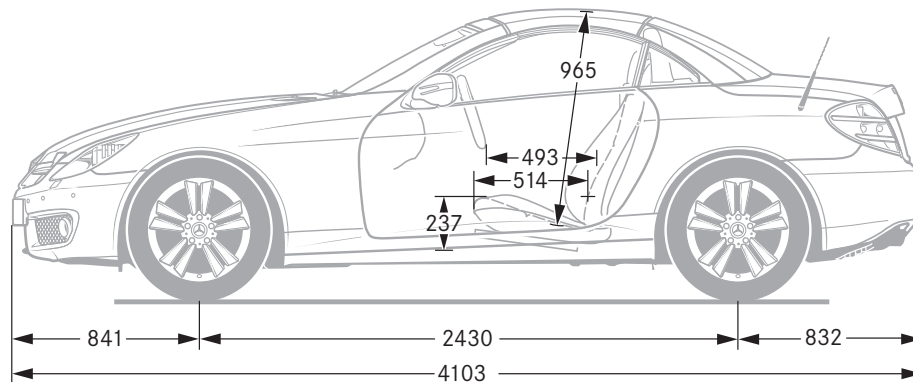
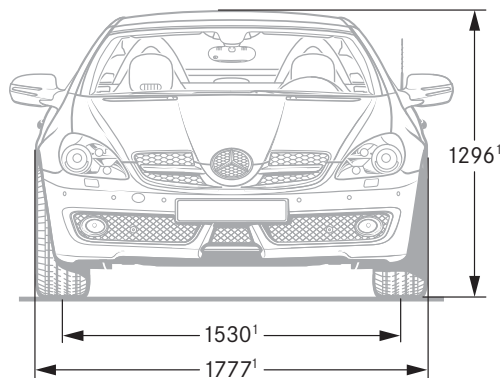

All measurements in millimetres. The dimensions shown are mean values and apply to standard-specification, unladen vehicles

<sup>1</sup>Dimensions apply to SLK 200 KOMPRESSION and may differ for other models





# Anyone opting for a Mercedes buys far more than just a car

**Mercedes-Benz Museum.** More than 120 years of automotive history in one place – this is what awaits you at the Mercedes-Benz Museum in Stuttgart. Experience the unique excitement, and embark upon a thrilling journey through time. Housed inside an architecturally impressive building, over 1500 exhibits on nine levels give you an insight into the unique tradition and powers of innovation of the Mercedes-Benz brand. See the world's first two automobiles in the shape of the Benz Patent-Motorwagen (motor car) and the Daimler motorised carriage - both from the year 1886. Two linked circuits take you from the beginnings of the automobile, past a series of unforgettable classics, through more than 100 years of motor racing history and, finally, on to a glimpse of what the future holds – in an area covering a total of 16,500 square metres. Enjoy the unique brand experience. We look forward to your visit. Further details can be found at [www.mercedes-benz.com/museum](http://www.mercedes-benz.com/museum)

**MercedesCard.** The card is your ticket to the Mercedes-Benz experience: four times a year, we will send you exciting details of a selected range of events and services, which we have put together exclusively for you. Then there is the Mercedes Magazine with its fascinating reports and articles. But the MercedesCard also has many other uses: as a VISA credit card, it is an internationally accepted means of payment. Plus it offers further benefits to provide you with peace of mind, such as the exclusively compiled MercedesCard insurance package at a preferential price. You can also gain free entry to the Mercedes-Benz Museum simply by showing your VISA MercedesCard. Further details can be found at [www.mercedes-benz.de/mercedescard](http://www.mercedes-benz.de/mercedescard)<sup>1</sup>

**Mercedes-Benz Financial Services.** Mercedes-Benz stands for quality, innovation and safety - and the same applies to Mercedes-Benz Financial Services. Our innovative leasing and financing products are tailored to your financial needs and means, making it easy for you to secure the keys to your dream car. Once you are on the right road, our insurance products offer you just the right level of protection on every trip. Finally, our service products ensure that your car is always in tip-top condition whilst keeping costs transparent and easily manageable. For a detailed quotation, please contact your Mercedes-Benz dealer, who will be glad to go through the latest financial offers and terms together with you.

<sup>1</sup> Information about the MercedesCard in Austria and Switzerland can be found on the Mercedes-Benz websites for these countries



**Mercedes-Benz mobility.** Your new car comes with the assurance of carefree driving, but if you should ever need help Mercedes-Benz Service24h is there for you. Just call the freephone service hotline on 00800 1 777 777<sup>2</sup>. The newly integrated telematics service Mercedes-Benz Contact<sup>3</sup> is even more customer-friendly: a touch of a button is all it takes to contact the Mercedes-Benz customer centre. If you wish, the relevant vehicle and position-related data can be transmitted at the same time, ensuring the shortest possible reaction time and rapid assistance. Also standard with your new car at no extra charge is the Mercedes-Benz Mobilo<sup>4</sup> mobility package. Whether you have lost your key, have had a breakdown which cannot be repaired immediately or if the vehicle is damaged due to an accident or vandalism, Mobilo ensures that you still reach your destination – anywhere in Europe. Whatever your problem, one thing is certain: you will soon be able to resume your journey.

**Service packages.** Vehicle-specific services allow you to put together an individual package for your Mercedes, including long-term protection against unforeseeable repair costs and high-quality servicing with genuine Mercedes-Benz parts. You can also count on the extensive network of Mercedes-Benz workshops, where you will receive the usual high standard of service for your Mercedes at a predictable, fixed price. Please ask your Mercedes-Benz dealer for further details.

**Test drive.** The unique feeling of driving a Mercedes cannot be put into words. Which is why we'd like to invite you to take a test drive. Simply visit [www.mercedes-benz.com](http://www.mercedes-benz.com) to locate the nearest Mercedes-Benz dealer in your country or region. We look forward to seeing you.

**Interactive Owner's Manual.** The website also offers an interactive tour, enabling you to take a closer look at your desired model. This simulation is the ideal way to acquaint yourself with your dream car. You can view key functions in detail, gain an insight into the car's inner workings or look at the benefits of each model. For further details, go to: [www.mercedes-benz.de/owners-manual](http://www.mercedes-benz.de/owners-manual)

**Mobile internet.** Now you can access the entire world of Mercedes-Benz from your mobile phone. As well as an overview of all the passenger car models, there are insights into the entire brand world along with a wealth of entertainment offers and direct links to our range of services at [www.mercedes.mobi](http://www.mercedes.mobi)

<sup>2</sup> Mobile phone rates vary according to service provider

<sup>3</sup> Only in conjunction with a factory-fitted radio and switched-on mobile phone. For the cost of a call to the landline network another year for a maximum of 30 years provided that regular maintenance is carried out by your Mercedes-Benz service partner

<sup>4</sup> When the warranty has expired Mobilo can be extended by

**Take-back of end-of-life vehicles.** Coming full circle. At the end of its long life, you can return your SLK-Class to us for environment-friendly disposal in accordance with the EC End-Of-Life Vehicle Directive<sup>1</sup>. But that day lies a long way off.

<sup>1</sup> Applies in accordance with national regulations to vehicles up to 3.5 tonnes gross weight. Mercedes-Benz passenger cars have met the statutory regulations governing the suitability of their design for reuse and recycling for a number of years now. A network of vehicle take-back depots and dismantlers has been established which will process your vehicle in an environment-friendly manner. The ways in which both vehicles and parts can be recovered are subject to ongoing development and improvement. Consequently, the SLK-Class will be able to comply with any future increases in the recycling quota within the stipulated time limits. For further information please call 00800 1 777 7777.

**Please note:** changes may have been made to the product since this brochure went to press (17.02.2010). The manufacturer reserves the right to make changes to the design, form, colour and specification during the delivery period, provided these changes, while taking into account the interests of the vendor, can be deemed reasonable with respect to the purchaser. Where the vendor or the manufacturer uses symbols or numbers to describe an order or the subject of an order, no rights may be derived solely from these. The illustrations may show accessories and items of optional equipment which are not part of standard specification. Colours may differ slightly from those shown, owing to the limitations of the printing process. This brochure has been compiled by Daimler AG of Germany and is distributed internationally. It provides a general indication of the range of models, features, optional extras and/or colours available in various countries. Some of the models, features, optional extras and/or colours may not be available in your country, or may only be available in a different specification. Additionally some models, features, optional extras and/or colours may only be available in combination with others. For current and more specific information in relation to the range of models, features, optional extras and/or colours available in your country, and their pricing, you should contact your nearest authorised Mercedes-Benz Passenger Car Dealer. [www.mercedes-benz.com](http://www.mercedes-benz.com)