

This Brochure is prepared by Daimler AG and it predominantly reflects the capabilities and performance of vehicles sold in Europe. Some characteristics, capabilities, performance features and optional extras (e.g. towing systems) may not be available or may not apply in Australia or under Australian conditions. The information in this Brochure is therefore indicative, illustrative and provided only for guidance and should not be relied on. To obtain current and accurate information on a vehicle and any options applicable to Australia, contact your local authorised Mercedes-Benz dealer.



Mercedes-Benz

The C-Class Coupé



Mercedes-Benz

pulling power. Even the 4-cylinder models come with the option of the 7G-TRONIC PLUS
s your rev counter. The low silhouette with a long, arrow-shaped bonnet. The upright,
end. Every inch underlines the character of this Coupé: built for people who don't like
timised drive technology - with a choice of three efficient petrol variants and two dies
optionally available 7G-TRONIC PLUS automatic transmission. Good news for CO₂ emi
ns which take account of practically every eventuality and thus help to prevent hazard
y to apply the brakes in anticipation of danger. So, if the worst comes to the worst, the
do you make something unique even more unique? The list of equipment is a good pla
or colour scheme, a piano lacquer trim and a leather look. The only things more indiv
Coupé is, the only inkling you get of gear changes is in the pulling power. Even the 4-c
of this for you. **More style per hour.** Contemporary driving requires intelligent drive s
nts and two diesel variants. Additional fuel-saving potential comes courtesy of the star



The C-Class Coupé embodies the tension between style and urgency. Externally, it is a compellingly attractive, dynamic coupé which expresses a strong sense of forward motion. Inside, it is a place to sit back and relish every corner and twist in the road in an ambience of sportiness and functional perfection. The result is sheer driving enjoyment.

Support is provided by engines equipped with the ECO start/stop function as standard, the sporty set-up of the AGILITY CONTROL suspension with selective damping system and features which set the standard for safety.

At a glance | from page 4 Insight | from page 22

Featured models:
C 350 BlueEFFICIENCY palladium silver metallic Cover and from page 2 AMG 7-spoke light-alloy wheels, flamenco red leather, dark brushed-aluminium trim, AMG Sports package
C 250 CDI BlueEFFICIENCY diamond white metallic BRIGHT from page 14 5-spoke light-alloy wheels in “sterling silver,” black ARTICO man-made leather, Style package

The illustrations may show accessories and items of optional equipment which are not part of standard specification

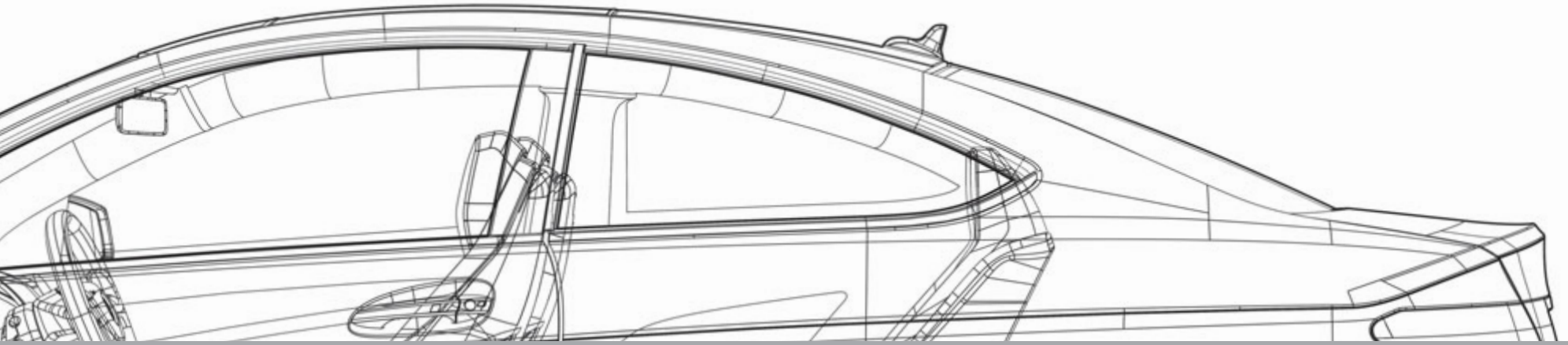

Stylish agility: BlueEFFICIENCY, diesel and petrol engines, transmissions and chassis

Drive system & chassis | from page 28

Reassuring safety: the innovative safety systems for the “Safe driving”, “In the event of danger” and “In an accident” phases

Safety | from page 36

Entertaining relaxation: multimedia and assistance systems, interior appointments

Comfort | from page 40

Sporty agility: the flagship C 63 AMG Coupé with a 6.3-litre V8 engine

AMG | from page 46

Desirable versatility: standard equipment and optional extras, packages, light-alloy wheels and accessories

Equipment & appointments | from page 54

Exciting professionalism: all you need to know about MercedesCard, Mercedes-Benz Financial Services, Mercedes-Benz mobility, Mercedes-Benz Museum, Test drive, Interactive Owner’s Manual, Mobile internet, Service packages and Accident repairs

Services | From page 72

Detailed listings: technical data, dimensions and paintwork

Facts & colours | from page 74

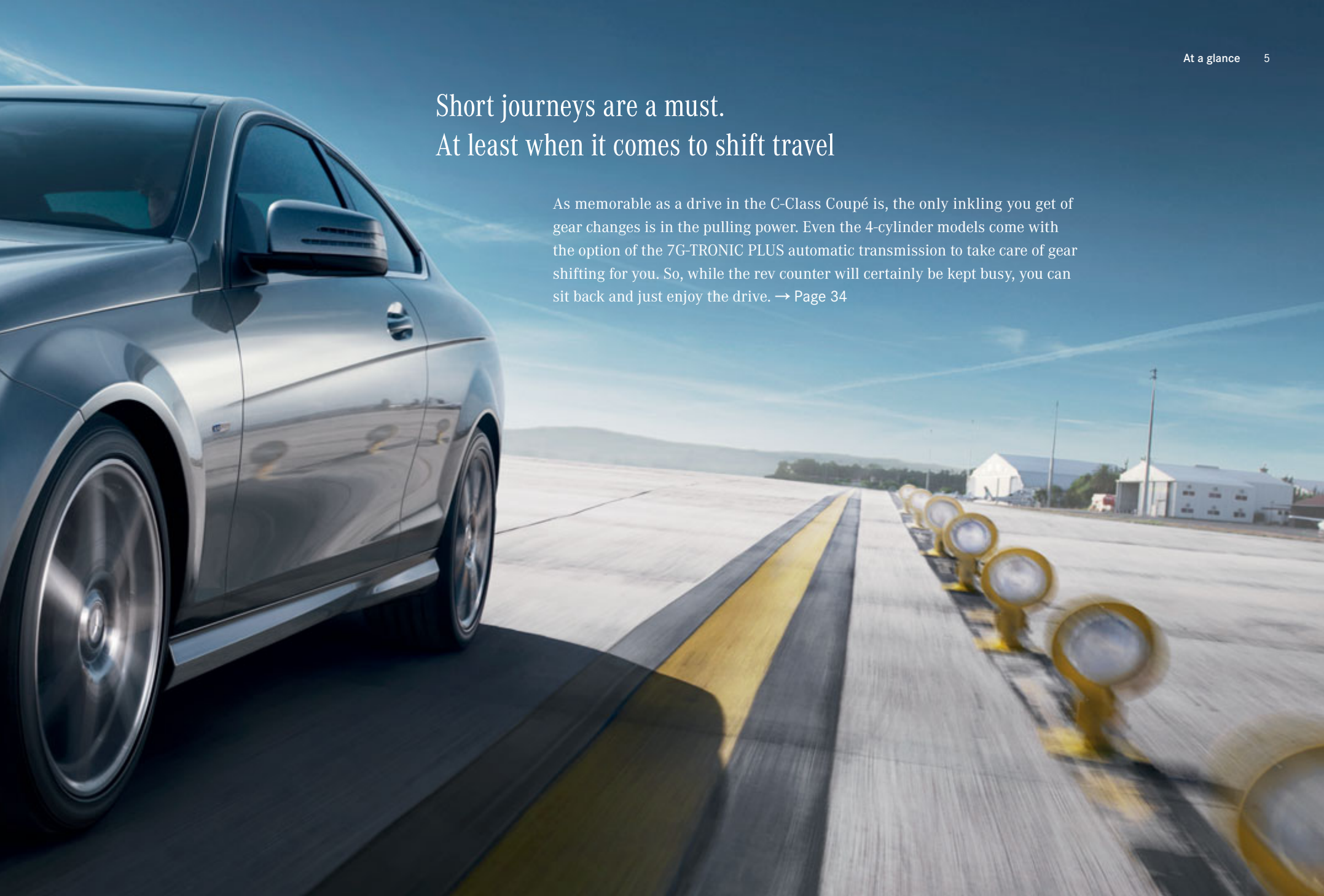

A silver Mercedes-Benz C-Class Coupé is shown from a low-angle, rear-quarter perspective, driving on a runway. The car is in motion, with a blurred background of a clear blue sky and distant airport buildings. The runway has a yellow center line and a row of yellow lights on the right side. The overall scene conveys a sense of speed and precision.

Short journeys are a must. At least when it comes to shift travel

As memorable as a drive in the C-Class Coupé is, the only inkling you get of gear changes is in the pulling power. Even the 4-cylinder models come with the option of the 7G-TRONIC PLUS automatic transmission to take care of gear shifting for you. So, while the rev counter will certainly be kept busy, you can sit back and just enjoy the drive. → Page 34

Two doors, no compromises.
As coupé as it gets!

The low silhouette with a long, arrow-shaped bonnet. The upright, louvred radiator grille with a central star, the strong shoulders, short overhangs and a powerfully thrusting rear end. Every inch underlines the character of this Coupé: built for people who don't like to stand still.





Brief care instructions:
needs tarmac beneath its tyres every day







Don't think too much about the environment.
We've already done that for you

Intelligent drive systems are a sign of the times. That's why the C-Class Coupé features optimised engine technology – with a choice of three efficient petrol variants and two diesel variants. Additional fuel-saving potential comes courtesy of the standard-fit ECO start/stop function and the optionally available 7G-TRONIC PLUS automatic transmission. Good news for CO₂ emissions. → Page 30–34



Welcome to the coupé lounge







Just what you need: a seventh sense

The C-Class Coupé is always a little bit further ahead than you think. Thanks to numerous safety systems which take account of practically every eventuality and thus help to prevent hazardous situations. A perfect case in point is the ADAPTIVE BRAKE braking control system, which has the ability to apply the brakes in anticipation of danger. So, if the worst comes to the worst, the car can be brought to a stop even more quickly. It's reassuring for all concerned, not just your heart rate.





Maybe your first Mercedes.
Almost certainly not your last







Standing ovation





How do you make something unique even more unique? The list of equipment is a good place to start. The Style package, for example, emphasises the car's expressive character with a contrasting interior colour scheme, piano lacquer-style trim and a leather look. The only things more individual than the interior are the places to which this Coupé can take you. → Page 44, 61

How do you design exhilaration?





Aerobatic pilots perform their daredevil manoeuvres as if in a frenzy, mastering figures at breathtaking speed. Suddenly, they appear to hang in the air for a moment. The spectators hold their breath in total silence. Then the plane plummets towards the ground, seemingly out of control. Yet at no point does the pilot lose control of his machine. With his hands firmly on the joystick, he halts the plane's fall and starts to spiral upwards. The flown figure is an expression of agility and the thought processes behind it are shared by aeronautical and automotive engineers alike. Because both the form and the character of every car start to take shape on the drawing board. But how do you design enjoyment? How can you make people see and, above all, experience it?

It's like the figures flown in aerobatics: what looks like a game is actually a matter of the utmost accuracy and precision. Because driving pleasure means perfect mastery of the machine. It is created on the fine line between optimum driver assistance provided by control and safety systems on the one hand and maximum performance on the other. For example, numerous assistance systems provide support but are not perceived as restrictive. The designers use their ability to balance these factors in order to achieve their ultimate aim: creating a car with agility and dynamism to lend wings to its driver's imagination.

Upholstery and trim. In an accident. Metallic paints. Sound system. Petrol engines. AMG
Transmission. Optional extra. Fuel consumption. Interior. In the event of danger. LED daytime
ESP[®]. Dimensions. Standard equipment. Light. Multimedia systems. Drive system. Gear
box. Transmission. Surround sound system. Wheels. Interior. Safe driving. CO₂ emission
n. Assistance systems. BlueEFFICIENCY. In an accident. Metallic paints. Petrol engine
speed. Chassis & suspension. Optional extra. Fuel consumption. Interior. Airbags. In the
colours. Climate control. Seats. ESP[®]. Dimensions. Standard equipment. Light. Multime
missions. Memory package. Transmission. Surround sound system. Wheels. Interior. Acc
a. Interior. Services. Safety. Assistance systems. Upholstery and trim. In an accident. M
driving. Light-alloy wheels. Top speed. Optional extra. Chassis & suspension. Fuel con
Engines. AMG. **The facts.** Paintwork. Total displacement. Climate control. Seats. Dime
pointments. Light-alloy wheels. Memory package. Transmission. Surround sound syste

28	BlueEFFICIENCY	36	Safe driving ATTENTION ASSIST Intelligent Light System LED tail lights and adaptive brake lights Driving Assistance package Plus	40	Multimedia systems COMAND Online Harman Kardon® Logic 7® surround sound system Audio 20 Becker® MAP PILOT	46	C 63 AMG exterior
29	C-Class Coupé BlueEFFICIENCY	38	In the event of danger PRE-SAFE® Brake and BAS PLUS PRE-SAFE® system	42	Assistance systems Speed Limit Assist Reversing camera PARKTRONIC incl. Parking Guidance Lane Tracking package	48	C 63 AMG interior
30	Diesel engines 4-cylinder	39	In an accident NECK-PRO head restraints Airbags Active bonnet	44	Seats Coupé seats Individual rear seats Memory package	50	C 63 AMG technology AMG 6.3-litre V8 engine AMG sports suspension AMG SPEEDSHIFT MCT 7-speed sports transmission
32	Petrol engines 4-cylinder 6-cylinder			52	AMG Performance Studio		
34	Transmissions 6-speed manual transmission 7G-TRONIC PLUS						
35	Chassis & suspension AGILITY CONTROL suspension Dynamic Handling package with sports driving mode						

The C-Class Coupé in detail

54 Standard equipment**55 Optional extras****56 Equipment packages**

AMG Sports package

designo

Style package

62 Upholstery and trim**68 Wheels**

Standard wheels

Optional wheels

AMG wheels

70 Genuine accessories**72 Services**

MercedesCard

Mercedes-Benz Financial Services

Mercedes-Benz mobility

Mercedes-Benz Museum

Test drive

Interactive Owner's Manual

Mobile internet

Service packages

Accident repairs

74 Dimensions**74|77 Paintwork****75 Technical data**

BlueEFFICIENCY – Fast forward to tomorrow



Mercedes-Benz is quicker at getting future technologies to where it matters most: on the road. By the end of 2012, you will have more than 140 Mercedes-Benz models with BlueEFFICIENCY technologies at your disposal, all of which help you reduce your impact on the environment. Our BlueEFFICIENCY concept comprises innovations for efficient mobility as well as optimised processes all the way along the value chain.

The BlueEFFICIENCY measures – the Mercedes-Benz efficiency package. This package consists of comprehensive vehicle optimisations which ease the burden on the environment. Each model combines the most efficient engine with intelligent, latest-generation aerodynamic and energy-management measures. Such measures include the ECO start/stop function, which is being made available for an increasing number of models. The BlueDIRECT V6 and V8 petrol engines, which feature in several model series, deliver a much higher power output while reducing fuel consumption by up to 25%.

BlueTEC – the clean diesel. A modular emission-control system makes BlueTEC an exceptionally clean diesel technology. As well as removing 95% of the particulate, it also reduces nitrogen oxides by up to 90%. What remains is mainly water and nitrogen.

HYBRID – petrol and electric drives intelligently combined. Here the electric motor can be used both for accelerating and for recuperating braking energy, which is stored in the battery. What's more, the ECU shuts off the petrol engine when the speed is below 15 km/h. In this way, a HYBRID implements significant fuel savings.

BlueTEC HYBRID – clean diesel combined with electric drive. It marries the benefits of the HYBRID with those of BlueTEC: during braking, the kinetic energy is converted into electrical energy, which can be re-used when required. At the same time, the BlueTEC technology cleans the exhaust gases and removes many of the pollutants. All of which makes the economical diesel powerplant even more efficient and clean.

Innovative drive systems that break new ground: E-CELL and F-CELL. We have developed two locally emission-free drive systems which have been produced on a small scale since 2010. The B-Class F-CELL¹ uses hydrogen to produce power for the electric motor, while the A Class E-CELL¹ draws its energy directly from two lithium-ion batteries.

But that is not all: under the banner “Design for Environment”, we also look at a vehicle's entire lifecycle and work hard to preserve the environment from the planning stage right through to recycling. In addition, we are involved in the development of alternative fuels and carry out research in the field of bionics. Further information about our comprehensive measures can be found at www.mercedes-benz.com/blueefficiency

¹ Provisional data: efficiency class: A++

The data are not based on an individual model and do not constitute part of the product offer; they are provided solely for purposes of comparison between different vehicle models

C-Class Coupé BlueEFFICIENCY

At Mercedes-Benz, BlueEFFICIENCY stands for trend-setting efficiency technologies and innovative measures. The C-Class Coupé models work with BlueEFFICIENCY technologies



Thanks to BlueEFFICIENCY, the C-Class Coupé requires very little fuel. That's because the engine is stopped automatically – largely unnoticed by the driver – when the car is at or coming to a standstill. Intelligent energy management reduces the energy consumption of ancillary components. Tyres with optimised rolling resistance and the car's optimised aerodynamics further lower the amount of energy consumed.

- 1 Radiator shutter
- 2 Improved aerodynamics
- 3 Weight optimisation
- 4 Engine optimisation
- 5 Intelligent energy management
- 6 ECO start/stop function
- 7 Driver information for energy-saving driving
- 8 Tyres with optimised rolling resistance
- 9 Energy-saving control of ancillary components
(power steering pump, fuel pump in the case of diesel engines)
- 10 Refrigerant compressor only activated when actually needed

Diesel engines

The diesel engines for the C-Class Coupé make for efficient, refined and powerful progress. They have higher outputs yet can consume far less fuel than their conventional counterparts

4-cylinder engines. The diesel powerplants incorporate a wealth of technical innovations. As a result, their output is up to 20% higher than that of comparable

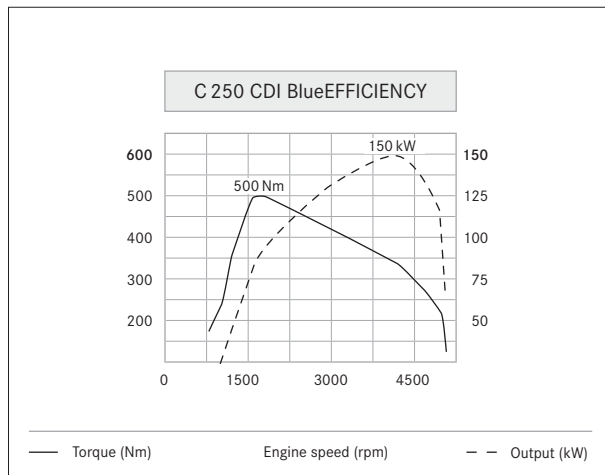

Impressive torque, even at low revs: ideal for spontaneous bursts of speed

older engines: the C 220 CDI BlueEFFICIENCY delivers 125 kW, the C 250 CDI BlueEFFICIENCY 150 kW. At the same time, the torque of both engines has been increased by up to 25%, while fuel consumption and CO₂ emissions are up to 23% lower. Both models also feature the ECO start/stop function and meet the requirements of the Euro 5 emissions standard.

One of the reasons behind the impressive performance of the diesel engines is the maximum injection pressure of up to 2000 bar. What's more, the required fuel quantity is metered extremely precisely – a sound basis for efficient and on-demand use of energy.

The diesel engines' astonishing consumption/output ratio is also down to their optimised combustion chamber design, which offers ideal conditions for maximising both clean combustion and energy efficiency. At the same time, the optimised alternator management helps take

the strain off the engine by seeing to it that the alternator is only activated when it is actually needed. A further technology which promotes responsible-minded driving pleasure is the efficiency-enhancing turbocharger. Plus there are two balancer shafts to ensure even smoother running.



The 4-cylinder diesel engine is available with a choice of two outputs (C 220 CDI BlueEFFICIENCY shown here)



The 6-cylinder engine for the C 350 BlueEFFICIENCY combines agility with responsible-minded energy consumption

Petrol engines

Agility and efficiency go hand in hand, as demonstrated by the petrol engines. Both the 4-cylinder models and the V6 powerplant combine a high level of refinement with low fuel consumption

4-cylinder engines. One key aim of the current generation of 4-cylinder petrol engines is to ensure higher output and better acceleration but lower fuel consumption.

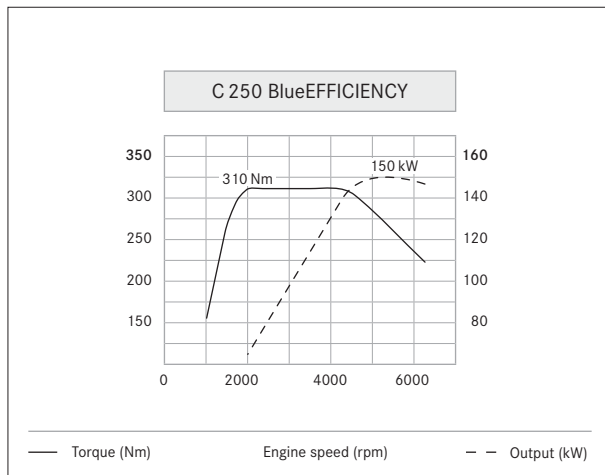

Not just remarkable in terms of performance data. The fuel-consumption figures set new standards, too

This aim is achieved with ease thanks to the BlueEFFICIENCY technologies – including the ECO start/stop function – and other optimisation measures which allow the engines to make do with less fuel.

Performance potential: the C 180 BlueEFFICIENCY with 7G-TRONIC PLUS accelerates from 0 to 100 km/h in just 8.9 seconds and goes on to reach a maximum speed of 223 km/h. The C 250 BlueEFFICIENCY has a top speed of 240 km/h and completes the sprint from 0 to 100 km/h in 7.2 seconds.

6-cylinder engine. Economical, clean and high-torque: the C 350 BlueEFFICIENCY heralds the arrival of a new generation of technology – drive concepts that are sparing in their use of resources. With combined fuel consumption of 7.0–6.8 l/100 km, the engine has a peak output of 225 kW and can accelerate the C-Class Coupé from 0 to 100 km/h in a mere 6.0 seconds.

The maximum torque of 370 Nm is on tap across a particularly wide engine speed range, so impressive power reserves are available for practically any driving situation.

This astonishing performance is the result of many features, including continuously variable camshaft adjustment, which allows precise, on-demand use of fuel. At the same time, the current generation of direct petrol injection technology, supported by spray-guided combustion and piezo injectors, minimises fuel consumption.

Transmissions

The two transmissions available for the C-Class Coupé deliver optimum pulling power in every driving situation

6-speed manual transmission. The 6-speed manual transmission combines sporty and economical driving. The ratio optimised in line with the engine output and the extremely precise, short shift travel make for exceptionally smooth gear changes. What's more, the integrated gearshift-recommendation function, ECO start/stop function and current consumption indicator can help to optimise fuel consumption and reduce emissions. For instance, the ECO start/stop function stops the engine when the car is at or coming to a standstill – at traffic lights, for example – before restarting it when the clutch or accelerator pedal is pressed.

7G-TRONIC PLUS. The efficiency-optimised 7G-TRONIC PLUS automatic transmission is one of the major factors behind the exceptionally high level of driving enjoyment. The seven forward gears allow a constantly optimised rpm level, meaning that fuel consumption can be reduced. But the transmission technology also comes into play when the driver wants to accelerate powerfully or experience the full range of the C-Class Coupé's agility. For example, individual gears can be skipped when overtaking or in situations requiring spontaneous acceleration. Furthermore, the transmission modes "C" (Comfort) and "S" (Sport) can be selected at the touch of a button.

The optional AMG Sports package and the optional Dynamic Handling package with sports driving mode also come with an additional "M" driving mode for manual shifts using the steering-wheel shift paddles. The 7G-TRONIC PLUS transmission is available as standard for the C 250 BlueEFFICIENCY and C 350 BlueEFFICIENCY models or as an optional extra for all other models.

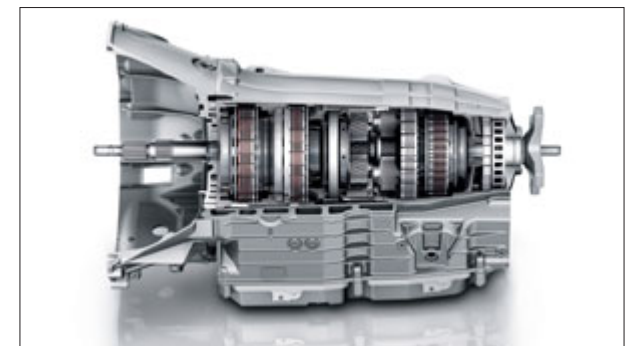

7G-TRONIC PLUS: one of over 18 million automatic transmissions produced in a period spanning more than 50 years

Chassis & suspension

The chassis technology for the C-Class Coupé allows comfort-oriented or sporty driving with supreme agility in almost any situation on the road

AGILITY CONTROL suspension (standard). The suspension with selective damping system can adjust automatically to the current road conditions and driving style. To do this, a valve automatically reduces the damping force at each wheel when the shocks caused by the road are weaker, thus lowering road roar and tyre vibration. If these shocks are stronger, the system's damping effect is enhanced and can improve the car's driving stability.

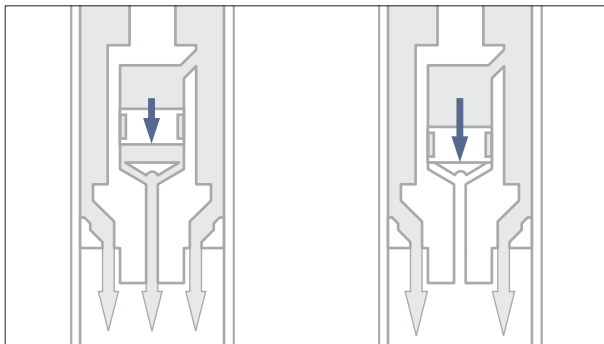

Outstanding agility and a high level of comfort: the AGILITY CONTROL suspension can adapt to any driving style

Dynamic Handling package with sports driving mode (option). The optionally available Dynamic Handling package with sports driving mode lends the C-Class Coupé even more dynamism and enhances the driving pleasure on every journey: in sports mode, the system not only adjusts the firmness of the damping, it also sharpens the accelerator response. Whatever the selected mode, the electronically controlled damping system constantly adjusts in line with the driving situation and

the state of the road. Driving pleasure is further enhanced by the 3-spoke multifunction steering wheel in nappa leather with shift paddles (in conjunction with automatic transmission). What's more, the speed-sensitive sports steering has a modified steering response map and a direct ratio for an exceptionally sporty feel. Finally, the lower-slung chassis delivers extra dynamism when cornering at high speed.



A suspension system lowered by 15 millimetres is one of the features which complements the Dynamic Handling package

Safe driving

The C-Class Coupé features safety equipment which helps to make everyday driving more relaxing and ensure better control in critical driving situations

ATTENTION ASSIST (included with the optional 3-spoke multifunction steering wheel with 12 buttons). ATTENTION ASSIST can warn the driver and recommend taking a break as soon as it detects signs of driver drowsiness. To do this, it monitors the driver's behaviour and, if this deviates from a previously determined profile, visual and audible warnings are emitted.



If ATTENTION ASSIST detects signs of drowsiness, the system recommends taking a break

Intelligent Light System with Adaptive Highbeam Assist and LED daytime running lamps (option). The system has six functions: country and motorway mode, enhanced fog lamps, cornering light function, active light function and Adaptive Highbeam Assist. The latter adjusts the low-beam headlamp range to provide optimum illumination in the prevailing traffic conditions. Main beam is activated if no other road users are detected. The headlamps can be dimmed automatically as soon as an oncoming vehicle with its lights on

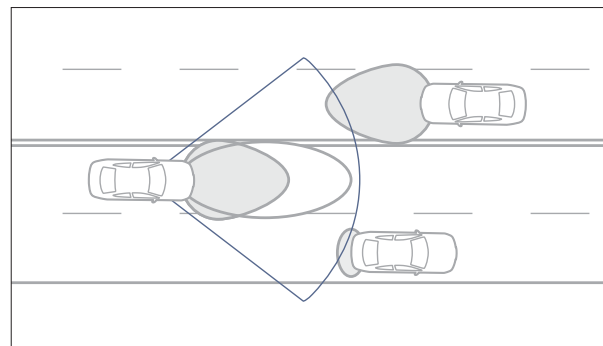

The Intelligent Light System adapts the car's lights to the current driving situation automatically

is detected. The LED daytime running lamps enhance perceptual safety during the daytime.

LED tail lights and adaptive brake lights (standard). During emergency braking, the adaptive brake lights flash 5.5 times per second to warn the traffic behind. If the car is braked to a complete stop from a speed in excess of 70 km/h, the hazard warning lamps are also switched on.



The LED tail lights and the adaptive brake lights enhance perceptual safety

Driving Assistance package Plus (option). At the touch of a button, the DISTRONIC PLUS adaptive cruise control can help the driver to maintain the desired distance behind a vehicle in front at speeds between 0 and 200 km/h and, if the need is detected, initiate braking. In this case, the radar-based system can brake the car to a standstill. It anticipates situations and builds up the necessary brake pressure. If the driver then fails to press the brake pedal hard enough, the system increases the brake pressure automatically. Thanks to

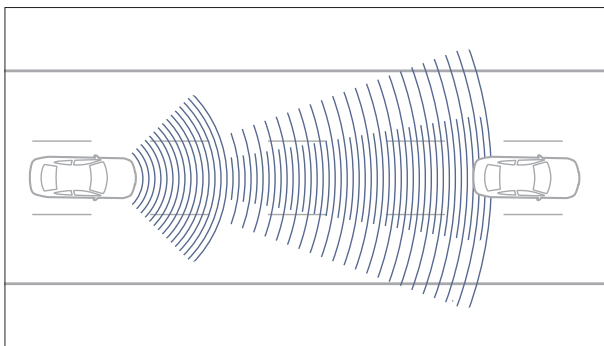

The DISTRONIC PLUS adaptive cruise control can brake the car to a standstill, for example when driving in a queue of traffic

the PRE-SAFE® Brake, the system can initiate emergency braking around 0.6 seconds before a possible collision to reduce the severity of the accident. Active Blind Spot Assist helps the driver when turning or changing lanes. A warning triangle lights up in the exterior mirror on the side of the car concerned if a vehicle is detected in the blind spot. If the driver fails to respond to the warning, the system can prevent a possible accident by automatically braking individual wheels. If the vehicle unintentionally crosses the detected lane

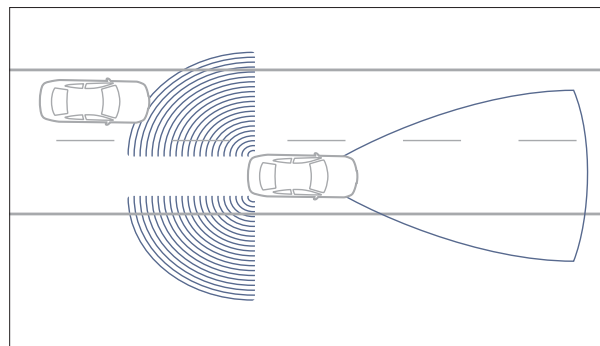

Active Lane Keeping Assist and Active Blind Spot Assist can support the driver in case of danger

markings and risks leaving its lane, Active Lane Keeping Assist warns the driver by making the steering wheel vibrate gently. If the driver fails to respond, individual wheels can be braked precisely to guide the vehicle back into its lane. Active Lane Keeping Assist recognises contrasts on the road ahead of the vehicle and is therefore able to “read” lane markings. It also observes the driving style and the line taken by the car, analysing these data for movements typical of a vehicle leaving its lane unintentionally. In this way, the system is able to reliably distinguish between intentional and unintentional lane departures.

In the event of danger

Anybody who travels on the road will have to face a dangerous situation sooner or later. That's why a range of systems has been developed for the C-Class Coupé to help avoid possible accidents

PRE-SAFE® Brake and BAS PLUS (components of the optional Driving Assistance package Plus). PRE-SAFE® Brake provides the driver first with a visual warning, then an audible alert if a risk of collision is detected. During this phase, BAS PLUS calculates the brake pressure that is required to prevent a collision. If the braking force applied by the driver is not sufficient, then the system automatically increases brake pressure in a way that ensures the remaining braking distance is used to the fullest advantage. This means that the driver of the vehicle behind also has a better chance of avoiding a rear collision.

If the driver fails to respond to the signals, PRE-SAFE® Brake intervenes with autonomous partial braking,

giving the driver a tangible warning. At the same time, the PRE-SAFE® system also triggers other protective measures in preparation for a possible collision. Auton-

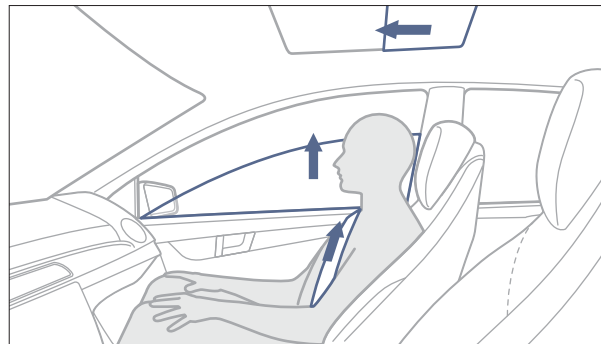

The PRE-SAFE® anticipatory occupant protection system helps to mitigate the consequences of accidents

omous emergency braking can then be activated if there is still no reaction from the driver. The result is a significant reduction in impact speed and accident severity.

PRE-SAFE® system (option). This anticipatory occupant protection system is able to detect certain critical driving situations in advance and activate preventive measures. If an imminent accident is detected, the system can close the side windows, move the front passenger seat equipped with the Memory package to a more favourable position and tension the front seat belts automatically. It can also close the sliding sunroof where fitted.

In the event of an accident

The C-Class Coupé provides a safer environment, even in the event of a collision. It is able to take numerous protective measures which can protect occupants and significantly reduce accident severity

NECK-PRO head restraints (standard). In the event of a rear impact, the sensor-controlled NECK-PRO head restraints for the front passengers can be pushed for-

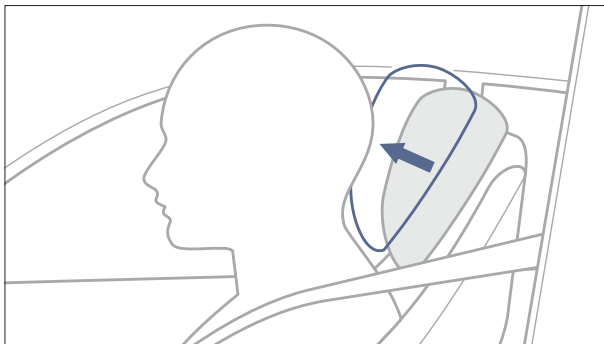

The NECK-PRO head restraints can help to reduce the risk of whiplash in an accident

ward and upward within a matter of milliseconds. They can thus reduce the gap between the head and the head restraint, thereby reducing the risk of injury.

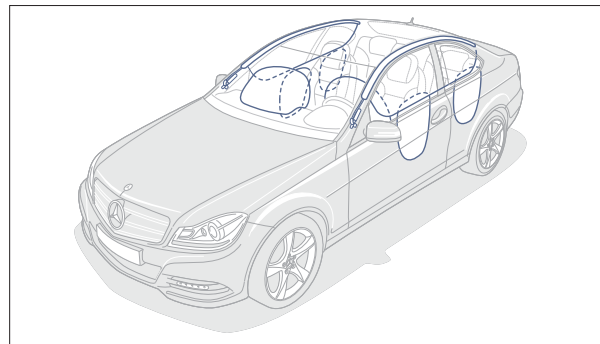

The robust passenger cell with defined crumple zones and the numerous airbags contribute to the exemplary occupant protection

Airbags (standard). The C-Class Coupé is equipped with numerous airbags which can help to reduce the risk of injury to passengers considerably in an accident. Driver and front-passenger airbags, sidebags and pelvisbags at the front, a kneebag for the driver, and windowbags are fitted as standard, while rear sidebags are optionally available.

Active bonnet (standard). The active bonnet can reduce the risk of injury to pedestrians and cyclists. In the event of an impact, its rear section is raised around five centimetres by means of spring force, thus creating additional deformation space to soften the blow for a pedestrian or cyclist.

Multimedia systems

To drive in style, you also need quality entertainment and helpful navigation. Cue our outstanding entertainment electronics and excellent navigation systems



As well as displaying navigation data in high resolution, the large TFT display also optimises the display of web and multimedia content

COMAND Online (option). The multimedia system boasts a high-resolution 17.8-cm colour display. The system's functions include a radio, speed-sensitive volume control, the MUSIC REGISTER with a 10 GB hard disc and hard-disc navigation. What's more, it also includes free European map data updates for three years following initial registration. The best in entertainment is provided courtesy of the DVD player, which can play CDs and MP3 files as well as video and audio DVDs. The online function facilitates access to the internet and various Mercedes-Benz mobile services via an internet-capable mobile phone. A USB connection, an Aux-in socket, a slot for SD memory cards and a Bluetooth® interface allow connection to external data storage media and a mobile phone. The system is operated using the central Controller and the buttons on the 3-spoke multifunction steering wheel. The LINGUATRONIC system allows you to control COMAND Online using voice commands.

Harman Kardon® Logic 7® surround sound system (option). The surround sound system with 450 watts is sure to make every one of your journeys an acoustic experience to savour. Twelve high-performance speakers and the Logic 7® multi-channel surround sound technology provide a three-dimensional sound impression. The automatic volume control adapts the sound in line with the car's current speed.



All you need for pure musical enjoyment: the Harman Kardon® Logic 7® surround sound system

Audio 20 with Bluetooth® interface, USB connection and Aux-in socket (standard). Includes a radio function as well as a CD player with MP3 capability. The system is controlled via the multifunction steering wheel and the TFT display with a screen diagonal of 14.7 cm. A mobile phone can be linked via Bluetooth® for hands-free operation. There are also numerous interfaces available.



Audio 20 with eight precisely tuned speakers for delivering outstanding sound

Becker® MAP PILOT (option). The Becker® MAP PILOT reliably gets you to your destination and has everything you look for in a sophisticated navigation system. It is installed in the glove compartment and can be simply controlled via the central Controller and the Audio 20 CD system's display. What's more, it can be further personalised by downloading updated map data and additional functions.

Assistance systems

The C-Class Coupé is designed to help you relax on the way to your destination. That's why it offers systems that can assist you and make your life easier in a wide range of traffic situations, for example when parking, when driving from city to city on roads with variable speed limits or when facing challenging road conditions



Speed Limit Assist shows the driver the current speed limit

Speed Limit Assist (included with the optional COMAND Online system). Speed Limit Assist can detect speed-limit signs and display them as symbols on the instrument cluster and in COMAND Online on the navigation screen. They remain displayed there until the speed restriction is lifted or changed. To this end, a windscreen-mounted camera monitors the area in front of the car on a permanent basis. The camera can filter out round traffic signs, be they speed-limit signs at the side of the road or on a gantry above the road. To detect the signs, the system also draws on the data stored in the navigation system's digital map, thus also enabling it to take account of the vehicle entering or leaving urban areas. Speed Limit Assist is especially helpful on routes with variable speed limits or road works.

Reversing camera (option). The reversing camera with wide-angle lens monitors the area directly behind the car and sends the images to the COMAND display. It is activated when reverse gear is engaged, thus enhancing safety when reversing into a parking space. The reversing camera is only available in conjunction with COMAND Online.



The reversing camera makes it easier to perform many manoeuvres when space is at a premium

PARKTRONIC including Parking Guidance (option). This electronic system helps the driver to look for and park in parking spaces. It emits audible and visual warnings as soon as it detects that the car is approaching an obstacle during a manoeuvre. It can also locate suitable parking spaces and provide the driver with precise instructions regarding the correct steering angle as well as the turn-in and turn-back points.



Parking Guidance automatically calculates the length of parking spaces at speeds up to 35 km/h

Lane Tracking package (option). Lane Keeping Assist can detect a traffic lane based on the road markings and, if the car is about to leave its lane unintentionally, warn the driver by making the steering wheel vibrate gently. Blind Spot Assist, meanwhile, uses two radar sensors in the rear bumper to monitor the blind spot at speeds above 30 km/h and can warn the driver against dangerous lane changes.



Blind Spot Assist is available as part of the optional Lane Tracking package

Seats

The C-Class Coupé is fitted with specially designed coupé seats including integrated head restraints and luxury individual rear seats. As well as being style-defining, the seat design offers extremely effective support, even during sporty driving, and perfect ergonomics



The standard-fit coupé seats are ergonomically designed. You can tell that they are made for a highly agile car: the C-Class Coupé

Coupé seats. Ergonomic coupé seats upholstered in a combination of ARTICO man-made leather and fabric await the driver and front passenger; ARTICO man-made leather or genuine leather upholstery is optionally available. Both the seat cushion height and the backrest inclination are electrically adjustable at the push of a button. Heated or climatized seats are available as optional extras.

Individual rear seats with integrated head restraints. The lounge-like character of the interior is also reflected in the ergonomic, individual design of the rear seats with integrated head restraints. An asymmetrically split and folding rear seat backrest is included as standard (except in the C 180 BlueEFFICIENCY). Convenience is further enhanced by the manually operated EASY-ENTRY system, which makes it easier to get into and out of the car.



Sheer comfort: it's easy for rear passengers to get into the car thanks to the EASY-ENTRY system, which moves the front seats fully forwards in one simple move

Memory package (option). This package extends the range of seat settings and, if several people drive the car, ensures that each driver can adopt their preferred sitting position quickly by calling up their own pre-programmed settings – for the driver's seat, steering column and exterior mirrors – at the touch of a button. In addition to this, the Memory package includes 4-way lumbar support for both the front seats.



The ergonomic driver's seat moves into the pre-programmed desired position at the touch of a button



C 63 AMG exterior

The C 63 AMG is the epitome of an expressive coupé. The AMG front apron, the AMG radiator grille with one chrome louvre, the unique AMG bonnet with powerdomes, the unique AMG daytime driving lights, the side sill panels and the rear apron with inset diffuser are just some of the features that demonstrate its commitment to performance. The AMG sports exhaust with two chromed twin tailpipes likewise emphasises the high-performance credentials of the Coupé and shows unequivocally that this particular Mercedes-Benz is powered by an AMG drive system. The exterior is completed to perfection by AMG light-alloy wheels, further underlining the fact that this is a highly responsive car built for motoring enjoyment. Further exterior features are listed below.



EXTERIOR

AMG 5-twin-spoke light-alloy wheels, painted titanium grey with a high-shine finish, with 235/40 R 18 front tyres and 255/35 R 18 rear tyres

AMG bodystyling, comprising front apron with side air outlets and cross strut in high-gloss black, side sill panels and diffuser-look rear apron

AMG high-performance braking system with 360 x 36 mm front brake discs and 330 x 26 mm rear brake discs

AMG spoiler lip on the boot lid

Distinctive, flared front wings with "6.3 AMG" lettering

Tail lights with LED technology







C 63 AMG interior

Powerful on the outside, stylish on the inside. The interior concept of the C 63 AMG Coupé is well thought-out, right down to the last detail. As soon as you open the doors, the AMG door sill panels tell you that this car is something truly special. Passengers are then welcomed by AMG sports seats upholstered in a combination of ARTICO man-made leather and DINAMICA in black or, as an option, designo leather (single-tone or two-tone). The AMG performance steering wheel, featuring flattened top and bottom sections, has aluminium shift paddles, while the AMG instrument cluster with colour display and AMG Start-up indicator is in an ergonomically ideal position. The black headlining and the AMG sports pedals complete the sporty ambience.

INTERIOR

AMG door sill panels in brushed stainless steel

AMG instrument cluster with 11.4-cm high-resolution colour display, incl. RACETIMER and AMG Start-up indicator

AMG performance sports steering wheel in nappa leather, with flattened top and bottom sections as well as silver-coloured aluminium gearshift paddles

AMG speed-sensitive sports steering

AMG sports seats in ARTICO man-made leather/DINAMICA in black

ATTENTION ASSIST

Brushed stainless-steel sports pedals with rubber studs

High-gloss black piano-lacquer-look trim

Rotary switch for selecting the four transmission modes and Race Start function

C 63 AMG technology

The AMG 6.3-litre V8 engine and the AMG SPEEDSHIFT MCT 7-speed sports transmission offer an emotional driving feel and driving dynamics at the highest level. But when it comes to choosing a sporty or comfort-oriented driving style, the driver always has the final say in the C-Class Coupé

AMG 6.3-litre V8 engine. A high-revving naturally aspirated engine with thoroughbred motor-racing technology: the vertical arrangement of the intake and exhaust ducts as well as the magnesium variable-intake manifold with two integrated throttle valves ensure optimum charging of the eight cylinders. Further high-tech features include the variable camshaft adjustment, four valves per cylinder, the stiff aluminium crankcase and the low-friction TWAS (twin-wire-arc-spraying) coating used for the cylinder walls. The V8 powerplant develops 336 kW at 6800 rpm, delivering impressive pulling power and a maximum torque of 600 Nm at 5000 rpm. Ideal ingredients for powerful acceleration in every engine speed range, as the driver always has over 500 Nm on tap between 2000 and 6250 rpm. Adding the AMG Performance package boosts the output by 22 kW to 358 kW, enabling the car to accelerate from 0 to 100 km/h in a highly impressive 4.3 seconds.

AMG sports suspension. Superlative driving dynamics and thrilling driving enjoyment come courtesy of the AMG sports suspension with AMG 5-twin-spoke light-alloy wheels with 235/40 R 18 front tyres and 255/35 R 18 rear tyres in combination with the specially designed three-link front suspension with a wider track, the AMG speed-sensitive sports steering and the three-stage ESP®. The AMG speed-sensitive sports steering has an even more direct ratio and, therefore, offers greater steering precision at high cornering speeds. The AMG sports suspension's stiff springs, gas-pressure shock absorbers and unique axle kinematics provide optimum agility at the driving limits as well as outstanding lateral dynamics. The AMG sports suspension therefore combines driving dynamics at the highest level with hallmark Mercedes long-distance comfort – and thus displays the characteristic attributes of a true AMG. The Electronic Stability Program ESP® has been specially adapted in line with the high level of driving

dynamics, as it allows the driver to select the level of assistance provided by the dynamic handling control system by choosing one of three different control settings: ON, OFF and SPORT HANDLING MODE. The activated setting is shown on the AMG instrument cluster's central display. The AMG high-performance braking system featuring large, internally ventilated and perforated brake discs ensures outstanding levels of deceleration and fade resistance. Not to mention perfect brake control and extremely short stopping distances.

Also available is the optional AMG performance suspension. With its even sportier spring and damper setup this suspension responds even faster and more directly to meet the very highest dynamic handling requirements.

AMG SPEEDSHIFT MCT 7-speed sports transmission.

Equipped with AMG aluminium steering-wheel shift paddles, four modes and a Race Start function, the 7-speed automatic transmission delivers enhanced driving dynamics and is highly efficient. The “S” (Sport), “S+” (Sport Plus), “C” (Comfort) and “M” (Manual) modes each have different gear-change characteristics and speeds: gear changes in “S” and “S+” modes are around 20 or 40 percent quicker than in “C” mode respectively - while in “M” mode gear changes take just 100 milliseconds, making them some 50 percent faster. A push of a button activates the desired driving mode: distinctly sporty or more comfort-oriented. There is also an automatic double-declutching function when downshifting, which provides an emotional sound experience as well as reducing power-off effects. This function has a positive effect when braking on the approach to bends in particular.

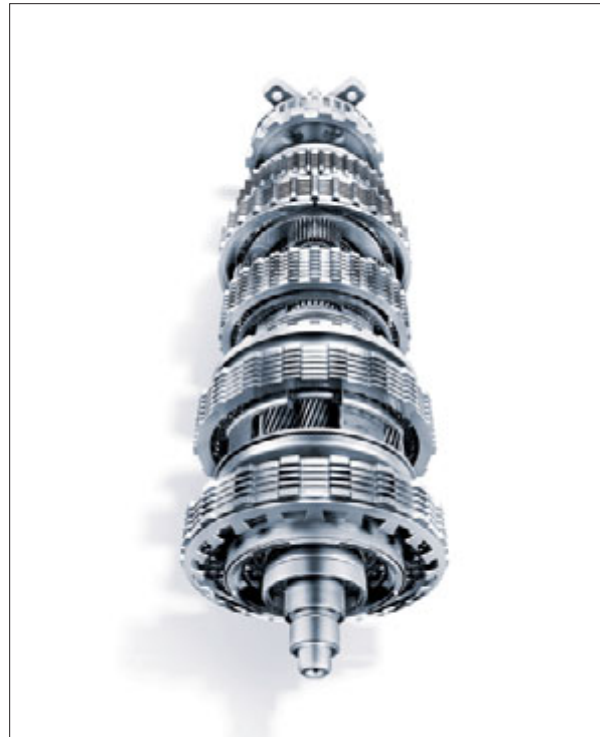

The AMG SPEEDSHIFT MCT 7-speed sports transmission offers customised modes for maximum driving pleasure



Motor-racing technology gives the AMG 6.3-litre V8 engine maximum agility





AMG Performance Studio

The C 63 AMG can be made even more sporty by the many exclusive features on offer from the AMG Performance Studio, such as the AMG Performance package, which includes a 22 kW boost in output, an AMG performance steering wheel in nappa leather/Alcantara®, AMG high-performance compound brakes on the front axle, an AMG carbon-fibre spoiler lip, red painted brake callipers at the front and rear, and a variable intake manifold painted in titanium grey. Over and above this, the AMG Driver's package provides a top speed of 280 km/h and includes participation in driving training at the AMG Driving Academy. The AMG Performance Studio in Affalterbach can meet customer requests for personalised vehicles, special optional extras and even one-off models.

AMG PERFORMANCE STUDIO

AMG carbon-fibre trim

AMG Driver's package

AMG door sill panels, illuminated with white LEDs at the front

AMG Exterior Carbon-Fibre package
(carbon-fibre spoiler lip and exterior mirror housings)

AMG floor mats

AMG rear-axle differential lock

AMG multi-spoke light-alloy wheels, painted titanium grey or matt black,
with 235/35 R 19 tyres at the front and 255/30 R 19 tyres at the rear

AMG performance suspension

Standard equipment | Selection



Daytime running lamps and front fog lamps



3-spoke multifunction steering wheel with 4 buttons in nappa leather, perforated in the grip area



THERMATIC automatic climate control



Coupé seats



LED tail lights



Audio 20 CD



ECO start/stop function



USB connection and Aux-in socket

Optional extras | Selection



Heat-insulating tinted rear window and rear side windows



Panoramic sliding sunroof



3-spoke multifunction steering wheel with 12 buttons in nappa leather, perforated in the grip area



KEYLESS-GO drive authorisation system



Intelligent Light System with Adaptive Highbeam Assist



Mirror package



COMAND Online multimedia system with LINGUATRONIC



Media Interface



AMG Sports package

The optionally available AMG Sports package lends the C-Class Coupé an even more dynamic and athletic appearance as well as enhancing its sporty agility. On the outside, it emphasises the Coupé's visible forwards thrust with AMG 7-spoke light-alloy wheels and AMG bodystyling, including front and rear aprons as well as side sill panels. The AMG Sports package also includes sports suspension and speed-sensitive sports steering to emphasise the car's effortlessly superior agility.



EXTERIOR

AMG 7-spoke light-alloy wheels with mixed-size tyres: 225/40 R 18 at the front and 255/35 R 18 at the rear

AMG bodystyling comprising front apron, side sill panels and rear apron

Brake callipers with Mercedes-Benz lettering, perforated front brake discs

Lowered sports suspension

Speed-sensitive sports steering

Tailpipe trim in polished stainless steel







AMG Sports package

The unique features of the optionally available AMG Sports package lend the interior of the C-Class Coupé extra dynamic touches: the 3-spoke multifunction sports steering wheel with a flattened bottom section allows the driver to change gear using steering-wheel shift paddles (only in conjunction with automatic transmission), while the speed-sensitive sports steering enhances the car's sporty handling. The headlining is finished in black fabric. A generously sized instrument cluster with an 11.4 cm colour display and ATTENTION ASSIST catches the eye without distracting the driver's attention from the road. The sporty interior is rounded off perfectly by an aluminium trim, brushed stainless-steel sports pedals and AMG floor mats.

INTERIOR

3-spoke multifunction sports steering wheel with flattened bottom section and 12 buttons, in nappa leather, perforated in the grip area

ATTENTION ASSIST

Brushed stainless-steel sports pedals with rubber studs

Dark brushed-aluminium trim

Floor mats in black with AMG lettering

Headlining in black

Instrument cluster with 11.4-cm high-resolution colour display

Steering-wheel shift paddles (only with automatic transmission)

designo

The designo range allows you to design the C-Class Coupé to an even higher standard and to your own taste

The wide range of exclusive designo appointments available as optional extras allows you to personalise an already exceptional vehicle. The single-tone appointments including seats and armrests in designo leather and leather-trimmed door centre panels featuring a hallmark designo look create a high-quality, exclusive atmosphere. Regardless of whether you choose the designo leather in sand, black, porcelain or classic red. And should you wish to further emphasise your Coupé's individuality, designo offers a vast range of additional options.



The two-tone appointments in designo leather highlight the Coupé's sporty, dynamic side. There is a choice of combinations available for the designo leather: sand/black, porcelain/black or classic red/black. As in all Mercedes-Benz models, the metal badge in the backrest is proof of meticulous material selection, exceptional quality, careful craftsmanship and individuality at the highest level. The interior is completed by the extended appointments in designo black leather comprising a leather finish for the upper section of the dashboard.



Style package

The Style package further emphasises the sporty and individual interior style of the C-Class Coupé

The Style package comprises a number of high-quality, harmoniously combined details. The upholstery in black ARTICO man-made leather with contrasting porcelain-coloured topstitching catches the eye straight away, while the 3-spoke multifunction sports steering wheel with twelve buttons is trimmed in leather with

a two-tone look, the lower section being finished in porcelain-coloured leather. The surface is perforated so that it is even easier to grip. This style is consistently matched by the trim, which is also in porcelain colour but with a piano lacquer look. The armrests, the door panelling, the shift/selector lever gaiter and the centre

console are accentuated by contrasting topstitching in porcelain colour, while the floor mats have porcelain-coloured edging.



Handcrafted perfection: the Style package individualises the interior of the C-Class Coupé



All the details combine to paint an impressive overall picture: the porcelain-coloured trim shines with a piano-lacquer look



Gearshift gaiter with contrasting topstitching in porcelain colour

Upholstery and trim



The seat upholstery in ARTICO man-made leather/fabric in black, included as standard, adds the perfect finishing touches to the Coupé's seats. The 3-spoke multifunction steering wheel is trimmed in nappa leather, while the headlining is finished in alpaca grey fabric. The A, B and C-pillars are likewise in alpaca grey. Black is the colour used for the dashboard, the load compartment cover and the door panelling. A black piano lacquer-look trim tastefully rounds off the interior design. The trim for the dashboard, centre console and doors is also optionally available in dark brushed aluminium or matt brown ash.



721

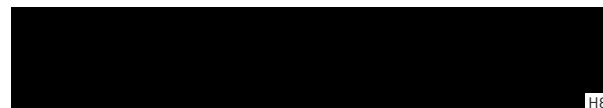

H80



739



H06

BLACK

721 ARTICO man-made leather/fabric

TRIM

H80 high-gloss black piano-lacquer look

739 dark brushed aluminium¹

H06 matt brown ash wood¹

¹ Optional extra



The seat upholstery in ARTICO man-made leather/fabric in alpaca grey, included as standard, adds the perfect finishing touches to the Coupé's seats. The 3-spoke multifunction steering wheel is trimmed in nappa leather, while the headlining is finished in alpaca grey fabric. The A, B and C-pillars and the door panelling are likewise in alpaca grey. The "split" dashboard is finished in black and alpaca grey, while the load compartment cover is black. A black piano lacquer-look trim tastefully rounds off the interior design. The trim for the dashboard, centre console and doors is also optionally available in dark brushed aluminium or matt brown ash.

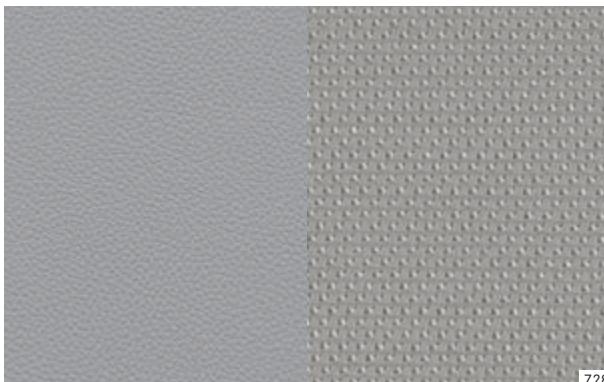

728

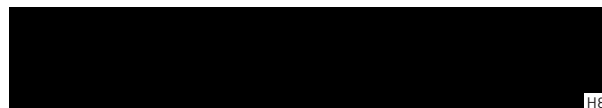

H80



739



H06

ALPACA GREY

728 ARTICO man-made leather/fabric

TRIM

H80 high-gloss black piano-lacquer look

739 dark brushed aluminium¹H06 matt brown ash wood¹¹Optional extra

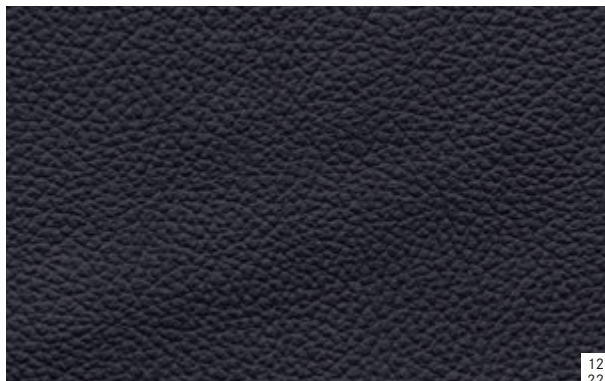

At the heart of the optional black colour scheme are the seats in a choice of black ARTICO man-made leather or black leather with alpaca grey topstitching. The 3-spoke multifunction steering wheel is trimmed in black nappa leather. The door panelling is also kept in black, while the headlining is finished in black fabric. The A, B and C-pillars, the dashboard and the load compartment cover are likewise in black. A dark aluminium trim tastefully rounds off the interior design. The trim for the dashboard, centre console and doors is also optionally available in a high-gloss black piano lacquer look or matt brown ash.

121
221

739

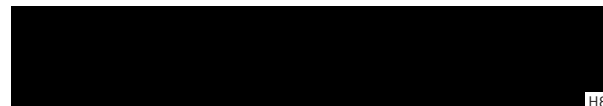

H80



H06

BLACK121 ARTICO man-made leather¹221 Leather¹**TRIM**

739 dark brushed aluminium

H80 high-gloss black piano lacquer look¹H06 matt brown ash wood¹¹ Optional extra

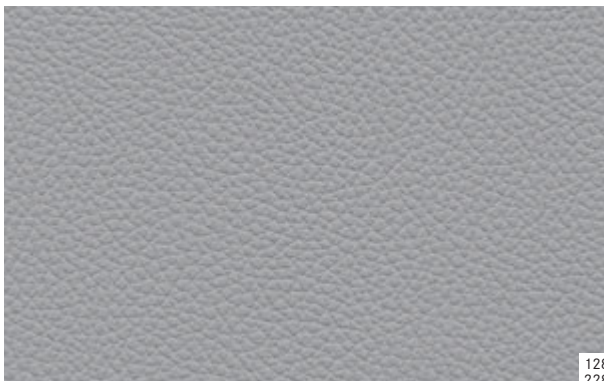

At the heart of the optional alpaca grey colour scheme are the seats in a choice of ARTICO man-made leather or leather in alpaca grey with dark alpaca grey top-stitching. The 3-spoke multifunction steering wheel is trimmed in black nappa leather. The door panelling is kept in alpaca grey, while the load compartment cover is in black. The headlining is finished in black fabric, while the A, B and C-pillars are likewise in black. The “split” dashboard is finished in black and alpaca grey. A dark aluminium trim tastefully rounds off the interior design. The trim for the dashboard, centre console and doors is also optionally available in a high-gloss black piano lacquer look or matt brown ash instead of aluminium.

128
228

739

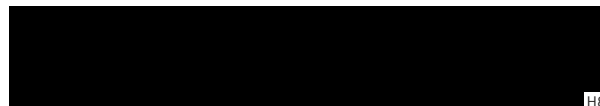

H80



H06

ALPACA GREY

128 ARTICO man-made leather¹228 Leather¹

TRIM

739 dark brushed aluminium

H80 high-gloss black piano lacquer look¹H06 matt brown ash wood¹

¹Optional extra



At the heart of the optional sahara beige colour scheme are the seats in sahara beige leather with topstitching in the same colour. The 3-spoke multifunction steering wheel is trimmed in black nappa leather. The door panelling is kept in sahara beige, while the roof lining is finished in black fabric. The A, B and C-pillars, the dashboard and the load compartment cover are likewise in black. A dark aluminium trim tastefully rounds off the exclusive interior design. The trim for the dashboard, centre console and doors is also optionally available in a high-gloss black piano lacquer look or matt brown ash.



235



739

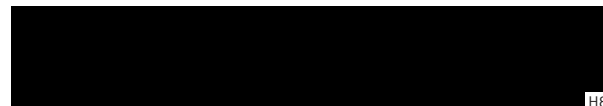

H80



H06

SAHARA BEIGE

235 Leather¹

TRIM

739 dark brushed aluminium

H80 high-gloss black piano lacquer look¹H06 matt brown ash wood¹

¹ Optional extra



At the heart of the optional flamenco red colour scheme are the seats in flamenco red leather with black topstitching. The 3-spoke multifunction steering wheel is trimmed in black nappa leather. The door panelling is kept in flamenco red, while the headlining is finished in black fabric. The A, B and C-pillars, the dashboard and the load compartment cover are likewise in black. A dark aluminium trim tastefully rounds off the interior design. The trim for the dashboard, centre console and doors is also optionally available in a high-gloss black piano lacquer look or matt brown ash.

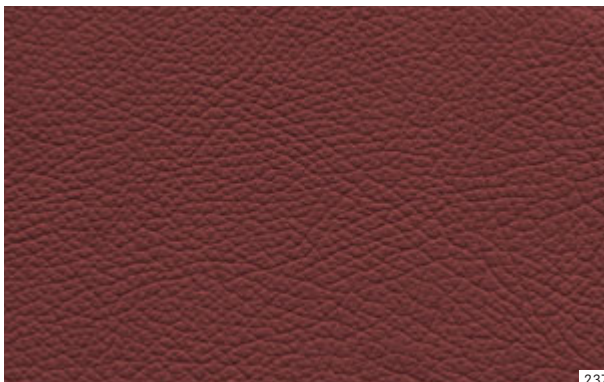

237



739

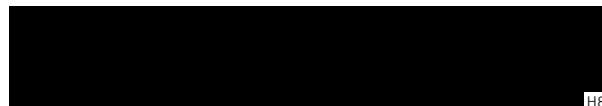

H80



H06

FLAMENCO RED
237 Leather¹

TRIM

739 dark brushed aluminium

H80 high-gloss black piano lacquer look¹H06 matt brown ash wood¹

¹Optional extra

Wheels



5-spoke light-alloy wheels in "sterling silver," with 225/40 R 18 front tyres and 255/35 R 18 rear tyres (optional, Code R36)



7-spoke light-alloy wheels with 195/60 R 16 tyres (standard for C 180 BlueEFFICIENCY, Code R20) or 205/55 R 16 tyres (standard for C 220 CDI BlueEFFICIENCY, Code R75)



7-twin-spoke light-alloy wheels with 205/55 R 16 tyres (optional, not available for C 350 BlueEFFICIENCY, Code R27)



10-spoke light-alloy wheels with 225/45 R 17 tyres (standard for C 250 CDI BlueEFFICIENCY, C 250 BlueEFFICIENCY and C 350 BlueEFFICIENCY, Code 25R)



5-twin-spoke light-alloy wheels with 225/45 R 17 front tyres and 245/40 R 17 rear tyres (optional, Code R95)



Multi-spoke light-alloy wheels with 225/45 R 17 front tyres and 245/40 R 17 rear tyres (optional, Code 56R)



7-spoke AMG light-alloy wheels with 225/40 R 18 front tyres and 255/35 R 18 rear tyres (standard wheels for AMG Sports package, Code 782)



5-twin-spoke AMG light-alloy wheels, painted titanium grey with a high-sheen finish, with 235/40 R 18 front tyres and 255/35 R 18 rear tyres (standard for C 63 AMG, Code 795)



5-spoke AMG light-alloy wheels, painted titanium grey with a high-sheen finish, with 235/40 R 18 front tyres and 255/35 R 18 rear tyres (optional for C 63 AMG, Code 790)



5-spoke light-alloy wheels with 225/45 R 17 front tyres and 245/40 R 17 rear tyres (optional, Code 639)



5-twin-spoke AMG light-alloy wheels with 225/40 R 18 front tyres and 255/35 R 18 rear tyres (optional, Code 786)



Multi-spoke AMG light-alloy wheels, painted titanium grey with a high-sheen finish, with 235/35 R 19 front tyres and 255/30 R 19 rear tyres (optional for C 63 AMG, Code 788)



Multi-spoke AMG light-alloy wheels, painted matt black, rim flange with a high-sheen finish, with 235/35 R 19 front tyres and 255/30 R 19 rear tyres (optional for C 63 AMG, Code 797)



Basic carrier bars and Mercedes-Benz roof box – with a choice of two sizes

Genuine accessories

The C-Class Coupé is a special car. The extensive range of Mercedes-Benz genuine accessories enables you to add further high-quality individuality

With genuine accessories from Mercedes-Benz, the C-Class Coupé can be made to reflect its owner's personal lifestyle. Those who like to travel with lots of luggage or sports equipment can add further stowage space by opting for the reliable and flexible carrier system and a 450 roof box which is easy to load and unload. The roof box is available in a choice of two sizes: the family box which holds around 450 litres or the sports box with a capacity of around 330 litres. Both boxes can be opened on both sides. Optional extras include a luggage set and a ski rack attachment.



Roof rack with "Luxury" ski and snowboard rack

A car as individual as the C-Class Coupé greets you every time you get in and out: with white-illuminated Mercedes-Benz lettering on the polished stainless-steel door sill panels.

Thanks to their distinctive styling, the high-end-design incenio light-alloy wheels further emphasise the individual aura of the C-Class Coupé. These light-alloy wheels are available in a choice of sizes and designs, for example 5-twin-spoke wheels with mixed-size tyres: 225/40 R 18 at the front and, optionally, 255/35 R 18 at the rear.



Illuminated door sill panels with "Mercedes-Benz" lettering

The range of genuine accessories offers a wide selection of high-quality products to choose from. Please see our accessories brochure for further details, or contact your Mercedes-Benz dealer who will be pleased to advise you.



incenio 5-spoke light-alloy wheels¹

¹ incenio light-alloy wheels are supplied without tyres

Services

MercedesCard. The card is your ticket to the Mercedes-Benz experience. Four times a year, we will send you the Mercedes Magazine, featuring fascinating reports from the world of Mercedes-Benz and articles about our latest vehicles. A MercedesCard also has many other uses too. As a VISA credit card, it is an internationally accepted means of payment. Further benefits are available to provide you with peace of mind, such as insurance packages for your Mercedes and other insurance services for the whole family. Further details can be found at www.mercedes-benz-bank.de¹

Mercedes-Benz Financial Services. Mercedes-Benz stands for quality, innovation and safety – and the same applies to Mercedes-Benz Financial Services. Our innovative leasing and financing products are tailored to your financial needs and means, making it easy for you to secure the keys to your dream car. Once you are on the road, our insurance products offer you comprehensive protection on every trip. Finally, our service products ensure that your car is always in tip-top condition whilst keeping costs transparent and easily

manageable. For a detailed quotation, please contact your Mercedes-Benz dealer, who will be glad to go through the latest financial services and terms and conditions with you.

Mercedes-Benz mobility. Your new car comes complete with the promise of feeling safe on the road, but if you should ever need assistance, then Mercedes-Benz Service24h is there to help. Just call the freephone service hotline on 00800 1 777 7777². The newly integrated telematics service, Mercedes-Benz Contact³, is even more customer friendly: a touch of a button is all it takes to contact the Mercedes-Benz customer centre. If you wish, the relevant vehicle and position-related data can be transmitted at the same time, thereby allowing the centre to react quickly and provide rapid on-the-spot assistance. Also standard with your new car at no extra charge is the Mercedes-Benz Mobilo⁴ mobility package. Whether you have lost your key, had a breakdown which cannot be repaired immediately or suffered damage to the vehicle due to an accident or vandalism, Mobilo is there to help you reach

your destination – anywhere in Europe. Whatever your problem, one thing is certain: you will soon be able to resume your journey.

Mercedes-Benz Museum. Experience 125 years of automotive history against an architecturally impressive backdrop. Over 1500 exhibits on nine levels give you an insight into the unique tradition and powers of innovation of the Mercedes-Benz brand in Stuttgart. See the world's first two automobiles in the shape of the Benz Patent-Motorwagen (motor car) and the Daimler motorised carriage – plus the automotive future of Mercedes-Benz – in an area covering a total of 16,500 square metres. We look forward to your visit – online, too, at www.mercedes-benz-classic.com/museum

Test drive. The unique feeling of driving a Mercedes cannot be put into words. Which is why we'd like to invite you to experience it for yourself. Take a test drive and find out first hand how it feels to drive your dream car. Simply visit www.mercedes-benz.com to locate your nearest Mercedes-Benz dealer.

¹ Information about the MercedesCard in Austria and Switzerland can be found on the Mercedes-Benz websites for these countries ² Alternative: +49 69 95 30 72 77. The only charge incurred is the cost of the mobile phone call to the landline network

Interactive Owner's Manual. The website also offers an interactive tour, enabling you to take a closer look at your desired model. Experience key functions in detail, gain an insight into the car's inner workings or look at the benefits of each model at www.mercedes-benz.de/owners-manual

Mobile internet. Now you can access the entire world of Mercedes-Benz from your mobile phone. As well as an overview of all the passenger car models, there are insights into the entire brand world along with a wealth of entertainment offers and direct links to our range of services at www.mercedes.mobi

Service packages. Vehicle-specific services allow you to put together an individual package for your Mercedes-Benz: for a small monthly premium the Excellent service package covers all service jobs including maintenance, wear and repairs – for up to five years. Simply present your service card and you will be safe from any financial surprises. And you can rely on the fact that your Mercedes-Benz will remain on top

form for a long time to come. With the Advance service package your Mercedes-Benz will stay at its best for longer still: you will be protected against unexpected repair costs even after the manufacturer's warranty or the service package has expired – for up to ten years.

Repair following an accident. Should the worst come to the worst, the Mercedes-Benz accident repair service provides you with the best help available for your vehicle, which will retain its valuable safety properties.



From work on the paint to bodywork or glass damage – optimally trained specialists will repair your Mercedes-Benz at your Mercedes-Benz service partner, and you will soon be back on the road again. Further information is available from your authorised Mercedes-Benz dealer.



³ Requires a factory-fitted radio linked up to a switched-on mobile phone. For the cost of a call to the landline network ⁴ Once the mobility warranty has expired, Mobilo can be extended in periods of one year for a maximum of 30 years, provided that regular maintenance is carried out by your Mercedes-Benz service partner

Paintwork

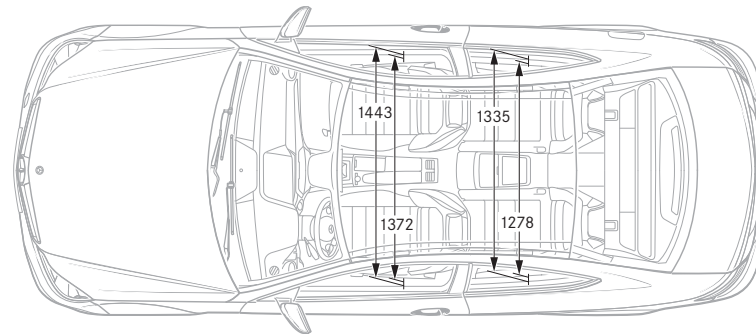
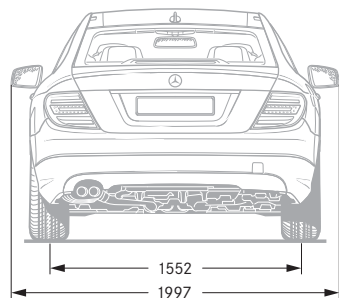
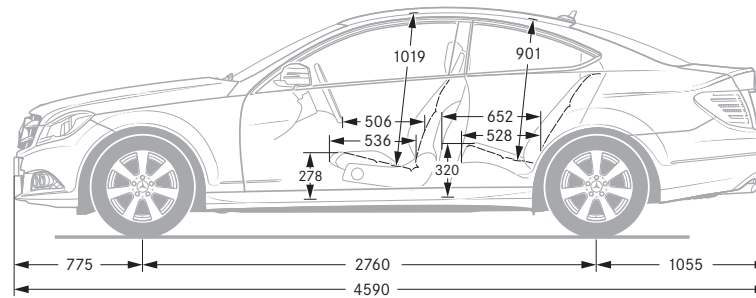
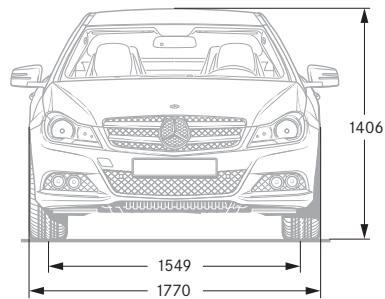

Paintwork

The innovative paint system developed by Mercedes-Benz includes one of the best clearcoats on the automotive market and is a key factor behind the car's excellent value retention. The secret lies in the exceptionally dense molecular structure, which makes both the metallic and the non-metallic clearcoats more resistant and produces a longer-lasting and visibly more intensive shine.

NON-METALLIC PAINTS (standard)

- 040 black
- 590 fire opal
- 650 calcite white

METALLIC PAINTS (option)

- 183 magnetite black
- 197 obsidian black
- 497 cuprite brown
- 755 tenorite grey
- 775 iridium silver
- 792 palladium silver
- 890 cavansite blue

SPECIAL METALLIC PAINT (option)

- 799 diamond white BRIGHT

Technical data

No. of cylinders/arrangement
Total displacement (cc)
Rated output ¹ (kW at rpm)
Rated torque ¹ (Nm at rpm)
Accel. 0-100 km/h (s)
Top speed, approx. (km/h)
Tyre size – front axle, rear axle
Fuel
Fuel consumption ³ (l/100 km)
Urban
Extra-urban
Combined
CO ₂ emissions ³ (g/km) combined
Efficiency class
Emissions standard
Tank capacity (l)/incl. approx. reserve
Boot capacity (l)
Turning circle diameter (m)
Kerb weight ⁴ (kg)
Perm. GVW (kg)

DIESEL ENGINES

C 220 CDI BlueEFFICIENCY	C 250 CDI BlueEFFICIENCY
4/in-line	4/in-line
2143	2143
125/3000-4200	150/4200
400/1400-2800	500/1600-1800
8.4 (8.1)	7.0 (7.1)
232 (231)	240
205/55 R 16	225/45 R 17
Diesel	Diesel
6.3-5.6 (6.5-6.1)	6.8-6.2 (6.5-6.1)
4.3-3.7 (4.6-4.2)	4.6-4.1 (4.6-4.2)
5.1-4.4 (5.3-4.9)	5.4-4.9 (5.3-4.9)
133-117 (139-128)	143-128 (139-128)
A (A)	A (A)
Euro 5	Euro 5
59/8	59/8
450	450
10.84	10.84
1615 (1630)	1655 (1660)
2085 (2100)	2125 (2130)

¹ Figures in accordance with Directive 80/1269/EEC in the currently applicable version ² Electronically governed ³ The figures shown were obtained in accordance with the prescribed measuring process (Directive 80/1268/EEC in the currently applicable version).
The figures are not based on an individual vehicle and do not constitute part of the product offer; they are provided solely for the purposes of comparison between different vehicle models

	PETROL ENGINES			
	C 180 BlueEFFICIENCY	C 250 BlueEFFICIENCY	C 350 BlueEFFICIENCY	C 63 AMG
No. of cylinders/arrangement	4/in-line	4/in-line	6/V	8/V
Total displacement (cc)	1796	1796	3498	6208
Rated output ¹ (kW at rpm)	115/5000	150/5500	225/6500	336/6800
Rated torque ¹ (Nm at rpm)	250/1600-4200	310/2300-4300	370/3500-5250	600/5000
Accel. 0-100 km/h (s)	9.0 (8.9)	- (7.2)	- (6.0)	- (4.4)
Top speed, approx. (km/h)	225 (223)	- (240)	- (250) ²	- (250) ²
Tyre size - front axle, rear axle	195/60 R 16	225/45 R 17	225/45 R 17	235/40 R 18, 255/35 R 18
Fuel	Premium petrol	Premium petrol	Premium petrol	Super Plus
Fuel consumption ³ (l/100 km)				
Urban	9.6-9.3 (9.0-8.8)	- (9.1-8.8)	- (9.6-9.4)	- (18.2)
Extra-urban	5.9-5.2 (5.8-5.1)	- (5.7-5.2)	- (5.6-5.3)	- (8.4)
Combined	7.3-6.7 (7.0-6.5)	- (7.0-6.5)	- (7.0-6.8)	- (12.0)
CO ₂ emissions ³ (g/km) combined	169-157 (162-150)	- (163-152)	- (164-159)	- (280)
Efficiency class	D (C)	- (C)	- (C)	- (G)
Emissions standard	Euro 5	Euro 5	Euro 5	Euro 5
Tank capacity (l)/incl. approx. reserve	59/8	59/8	66/8	66/14
Boot capacity (l)	450	450	450	450
Turning circle diameter (m)	10.84	10.84	10.84	11.10
Kerb weight ⁴ (kg)	1500 (1520)	- (1550)	- (1615)	- (1730)
Perm. GVW (kg)	1970 (1990)	- (2020)	- (2085)	- (2160)

¹Figures according to Directive 92/21/EC, version 95/48/EC (kerb weight with fuel tank 90% full, driver, 68 kg, and luggage, 7 kg) for standard-specification vehicles.

Optional extras and accessories will generally increase this figure and reduce the payload capacity accordingly. Figures in brackets apply to vehicles with automatic transmission. Further technical data can be found at www.mercedes-benz.com

NON-METALLIC PAINTS



METALLIC PAINTS

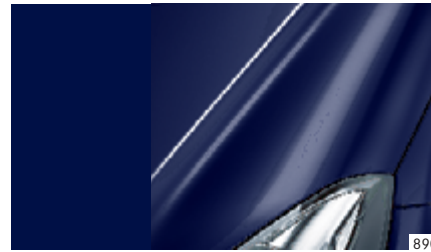
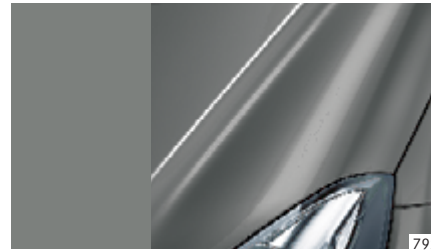

SPECIAL METALLIC PAINT



Take-back of end-of-life vehicles. Coming full circle. At the end of its long life, you can return your C-Class Coupé to us for environment-friendly disposal in accordance with the EU End-Of-Life Vehicle Directive¹. But that day lies a long way off.

¹ Applies in accordance with national regulations to vehicles up to 3.5 tonnes gross weight. Mercedes-Benz passenger cars have met the statutory regulations governing the suitability of their design for reuse and recycling for a number of years now. A network of vehicle take-back depots and dismantlers has been established which will process your vehicle in an environment-friendly manner. The ways in which both vehicles and parts can be recovered are subject to ongoing development and improvement. Consequently, the C-Class Coupé will be able to comply with any future increases in the recycling quota within the stipulated time limits.

Please note: changes may have been made to the product since this brochure went to press (22.07.2011). The manufacturer reserves the right to make changes to the design, form, colour and specification during the delivery period, provided these changes, while taking into account the interests of the vendor, can be deemed reasonable with respect to the purchaser. Where the vendor or the manufacturer uses symbols or numbers to describe an order or the subject of an order, no rights may be derived solely from these. The illustrations may show accessories and items of optional equipment which are not part of standard specification. Colours may differ slightly from those shown in the brochure, owing to the limitations of the printing process. This brochure is distributed internationally. It provides a general indication of the range of models, features, optional extras, colours and/or services available in various countries. Some of the models, features, optional extras, colours and/or services shown may not be available in your country or may only be available in a different specification. Additionally some models, features, optional extras, colours and/or services may only be available in combination with others. For current and more specific information in relation to the range of models, features, optional extras, colours and/or services available in your country, and their pricing, you should contact your nearest authorised Mercedes-Benz Passenger Car Dealer.

www.mercedes-benz.com