

This Brochure is prepared by Daimler AG and it predominantly reflects the capabilities and performance of vehicles sold in Europe. Some characteristics, capabilities, performance features and optional extras (e.g. towing systems) may not be available or may not apply in Australia or under Australian conditions. The information in this Brochure is therefore indicative, illustrative and provided only for guidance and should not be relied on. To obtain current and accurate information on a vehicle and any options applicable to Australia, contact your local authorised Mercedes-Benz dealer.



Mercedes-Benz

The G-Class



Mercedes-Benz

“Our philosophy is very simple. We give our best for people who expect the best.”

Dr Dieter Zetsche

Contents

The G-Class	6	My G-Class	36
Variants	8	Equipment & appointments	38
Refinement	10	Standard equipment	40
Petrol engines	10	Light-alloy wheels	44
BlueTEC	12	Optional extras	46
Transmissions	14	Special models	52
Frame and chassis	16		
On-road/off-road systems	18	Colours and materials	64
Comfort	22	Leather	66
Cockpit	22	Combination options	73
Interior	24	Interior	74
		Paintwork	77
Safety	28	Technical details	68
AMG	32	Dimensions	68
G 55 AMG	32	Technical data	79
AMG equipment	34	Services	70

Your destination: the horizon

The G-Class

Dynamism. Safety. Comfort. These are the classic attributes that make a car a Mercedes-Benz. And the G-Class – our classic cross-country vehicle – is no exception. The G-Class offers a unique take on these hallmark Mercedes-Benz attributes, even in the world's most remote locations where few vehicles make the grade.

The G-Class began its incredible journey back in 1979. Countless technical improvements and update measures have been introduced over the years. Yet its unique character remains firmly intact. On the following pages, we bring you the next stage of this journey. Follow the further-refined G-Class as it heads for new horizons. And discover how one of the classics in automotive history is shining in a new light.

The G-Class: heading for new horizons









The G-Class



Every legend has a hero. This one has three

The G-Class variants

The character of the G-Class has barely changed over the years. And why should it? After all, its distinctive form is a true design classic. Robust. Practical. Timeless.

Like every legend, the classic G-Class cross-country vehicle exists in several versions: from the prestigious long-wheelbase Station Wagon to the special “BA3 Final Edition” short-wheelbase Station Wagon to the Cabriolet, the latter being the only vehicle of its kind in this category. Also available is an AMG version of the long-wheelbase Station Wagon whose looks and performance put it in a class of its own (see the AMG section starting on page 32). Other highlights are the special models featuring a range of fine appointments and equipment options as standard (from page 52). But as different as the various versions of the G-Class may be, they all have an irresistibly compelling character.





On-road performance you just know will translate into off-road capability

Masters of every situation: the G-Class petrol engines

When you settle into your seat in a G-Class, you notice the difference immediately. The elevated position and the outstanding all-round visibility provide a clear indication of what is in store: the G-Class driving experience is something very special indeed.

When you then start the engine of the G 500 you cannot fail to notice that under the bonnet there is something exceptional: the powerful 5.5-litre V8 engine, perfectly in tune with the demands made by this versatile vehicle. With electronic petrol injection and four valves per cylinder, it ensures effortless power delivery at all times. And with 285 kW (388 hp) it can tackle the roughest terrain with the same poise and elegance it displays when breezing along the motorway – a characteristic that it quite clearly shares with the second petrol powerplant available for the G-Class: the AMG V8 supercharged engine. Further details about this can be found starting on page 32.

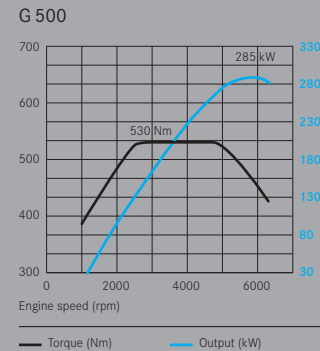

G 500. The G 500 achieves its peak torque of 530 Nm across a broad engine speed range from 2800 rpm to 4800 rpm

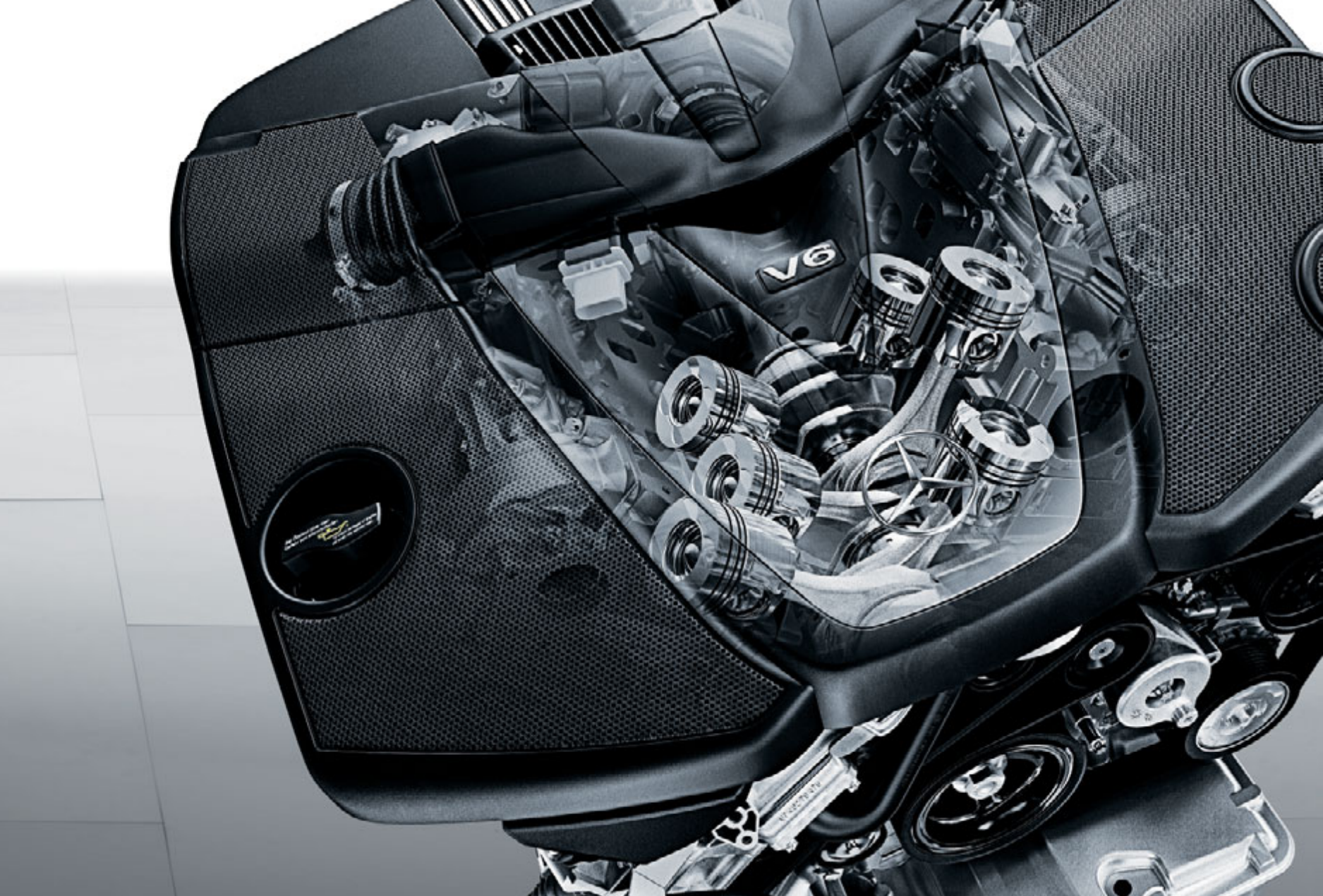

Ready equipped for the next climate summit

BlueTEC - the clean diesel

The enhanced BlueTEC technology in the new G 350 BlueTEC developing 155 kW ensures exceptionally low emissions. BlueTEC catalytic converter technology allows the cleaning and aftertreatment of exhaust gases using the AdBlue® urea solution, making this an extremely clean diesel drive system. What's more, AdBlue® can now be poured into the tank from outside just as easily as fuel, meaning that



Simple and practical. Top up the AdBlue® in the G 350 BlueTEC just as you would the fuel

topping up is never a problem – even when driving off-road.

Exemplary emission figures, low fuel consumption, effortlessly superior performance and a high torque of 540 Nm – the G 350 BlueTEC sets the lead for others to follow.

G 350 BlueTEC

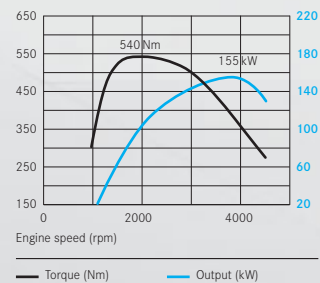

G 350 BlueTEC. The 3-litre V6 diesel engine delivers its powerful torque of 540 Nm over an engine speed range of 1600 to 2400 rpm

The more fluid the movement, the better the performance

The G-Class automatic transmissions

Sports stars hone their movements to perfection over a period of years, their theory being that smooth, fluid movements make for outstanding performance.

Inspired by this, the Mercedes-Benz engineers have developed an extremely fluid sequence of movements for the standard-fit 7G-TRONIC automatic transmission in the G 350 BlueTEC and G 500. The gear changes are barely perceptible – even when a gear is skipped, as is necessary on occasions. So you are always in the right gear, leaving you to enjoy the superlative driving dynamics and quiet ride.

The G 55 AMG features the specially tuned 5-speed automatic transmission which transfers the immense power and high torque of the AMG engine to the wheels with consummate ease.



Selector lever. Smooth shifts every time: the wood/leather selector lever with Mercedes-Benz badge

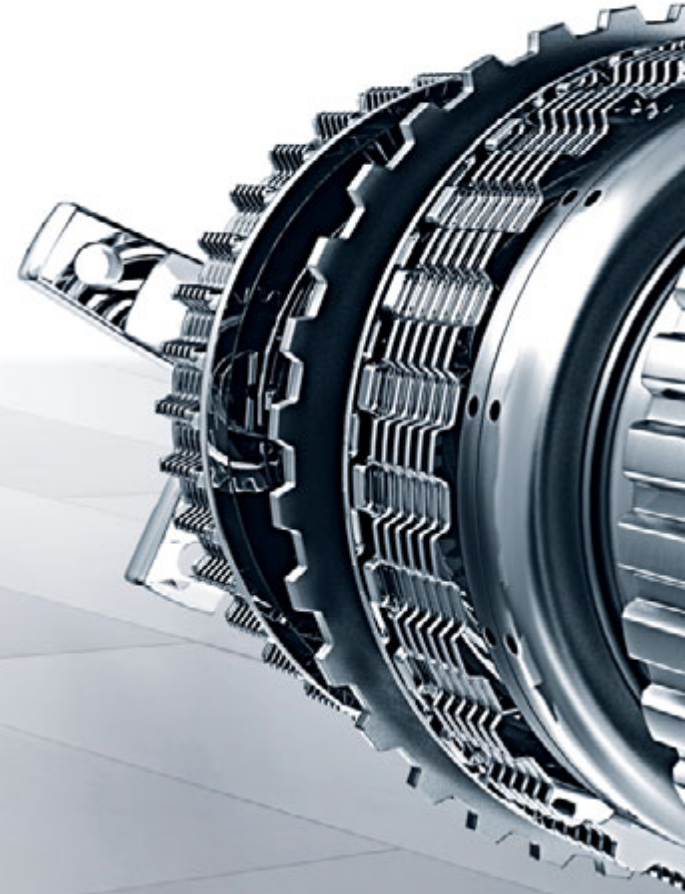



Tested to overcome any challenge

Frame and chassis configured for maximum performance

When building a G-Class, we leave nothing to chance. After all, longevity and value retention are key quality features that are a source of great pride for us.

With a section wall thickness of up to 4 mm, the G-Class frame is assembled with more than 6400 spot welds before undergoing cathodic dip-priming and powder coating. The vehicle floor is given an additional plastic coating and all the body variants also undergo thorough treatment in an electro dip-priming process before the application of several coats of paint. This level of protection means that the G-Class offers practically no scope for attack by water, snow, road salt or even desert sand.

These are the real challenges which await the G-Class off road and it prepares for them at our special all-terrain proving grounds. It is here that a G-Class has to win its spurs by demonstrating the off-road credentials that give it so much street credibility.

On demanding terrain, two precisely located rigid axles with high torsional flexing and long suspension travel ensure the necessary ground clearance and outstanding traction, meaning that the permanent all-wheel-drive system can also exert its full influence.



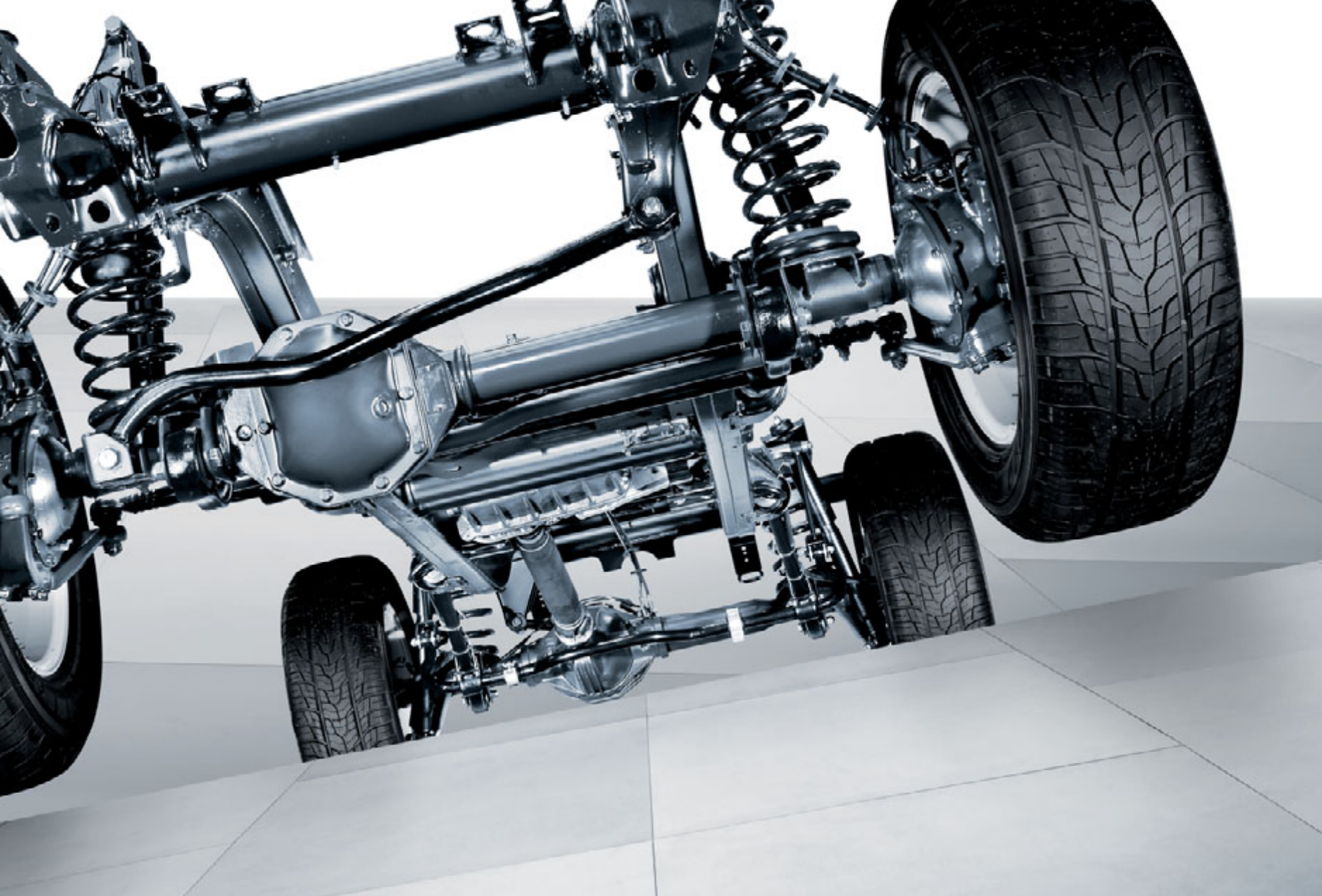

Power meets intelligence

Low-range ratio and traction system in the G-Class

Sheer force alone does not make for smooth progress in difficult conditions. For this you need immense power with intelligent control. Driver aside, it is the electronic traction system 4ETS that assumes this task in the G-Class, sending precisely the right amount of engine power to the wheels that offer the best traction from instant to instant and so making it much easier to maintain control on snow or ice-covered surfaces.

The driver receives additional assistance courtesy of the transfer case's off-road ratio – part of the standard specification. One press of the low-range switch is all it takes to activate this feature. At low speed and with maximum traction, the G-Class overcomes obstacles with ease. It climbs, clambers and scrambles but, above all, it demonstrates just what it takes to be a truly great cross-country vehicle.

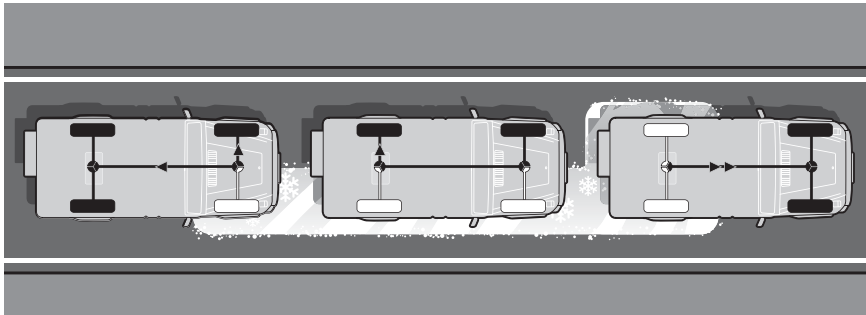

Greater traction thanks to 4ETS.

If up to three wheels have poor grip, they are braked by 4ETS. The tractive power is then directed to the wheel or wheels offering better grip





Go over the next patch of scree. Then turn left into the river bed

Fully lockable differential locks for full-on off-road driving

Teamwork simply makes it easier to achieve great things. This is why everything works together in the G-Class. For example, the permanent all-wheel drive, the electronic traction system 4ETS, the synchromesh transfer case and the three fully lockable differential locks. This teamwork is one of the outstanding features of the G-Class. It is what makes it a true cross-country vehicle. No other vehicle comes close to offering such a unique combination of attributes.

Fitted as standard, the three differential locks can be activated individually and in a logically specified sequence. So you can be sure that the G-Class adapts perfectly to its surroundings. If a wheel loses traction, the power is redirected to the wheels offering the best grip. Even if only one wheel is providing grip, your G-Class will still make good headway – an impressive achievement. And just perfect when driving off road.







One star at the front. Five stars inside

Clear, comfortable and well thought-out: the interior

A vehicle bearing the Mercedes star comes with the promise of quality and precision workmanship. Nowhere is this more impressively apparent than in the interior of the G-Class.

The generous feeling of spaciousness imparts a sense of freedom. And that's before the G-Class has even started moving. What's more, the characteristically high seating position ensures excellent all-round visibility at all times, while the cockpit is designed with ease of operation in mind.

You experience the comfort and convenience of a G-Class the second you open the doors and again when you close them. Attention to detail takes pride of place. As you will see when you touch the fine-leather-trimmed steering wheel which, of course, swings upwards once you have parked, to make getting out even easier. A service that merits five stars all of its own.

On the following pages you can familiarise yourself with the G-Class equipment and appointments. Apart from which, we will show you how to create your own individual G-Class (page 46 onwards).



Everything under control. The multifunction steering wheel is available as standard in leather (G 350 BlueTEC) or wood/leather (G 500 and G 55 AMG)



It's hard to believe that chrome isn't a precious metal

The Chrome package for the G-Class

The Chrome package allows you to underline the innate elegance of your G-Class. It comes as standard with the G 55 AMG and is available as an option for the G 350 BlueTEC and G 500. And you can cut a fine figure with the AMG radiator grille with chrome highlights. The interior is afforded an especially high-quality feel courtesy of the automatic transmission selector lever, which is framed in chrome, as well as the chrome trim surrounding the wood panel housing the seat adjustment switches and chrome rings around the speaker grilles in the front doors. Another eye-catching detail is the chrome door sill panel in the load compartment featuring Mercedes-Benz lettering (AMG lettering for the G 55 AMG). So you're certain to draw admiring glances whether you're off the beaten track or about town.



The automatic transmission selector lever framed in chrome

The G-Class takes your desire for freedom very seriously

With its exceptionally large load compartment capacity

Drivers who opt for a genuine cross-country vehicle generally have a particularly strong desire for freedom. And the G-Class interior caters to this too, offering a wealth of space. With the 1/2 : 1/2 folding rear seat bench in the “BA3 Final Edition” Station Wagon and Cabriolet (1/3 : 2/3 in the long-wheelbase Station Wagon), the load compartment capacity of up to 2250 litres provides plenty of room. So, whether you are off on a round-the-world trip or just off to play a round of golf, you can always count on having all the room you need.

For those who want even more space, the engine and chassis configuration allows a trailed load of up to 3.5 t. Whether you are towing a yacht, a horsebox or a caravan, the G-Class grants you smooth and swift passage almost regardless of the load and terrain.









A safe bet for even the most intrepid of explorers

On-board safety technology - from Mercedes-Benz

We set the first milestone back in the 1950s with the invention of the safety passenger compartment. Since then Mercedes-Benz engineers have come up with further safety-enhancing innovations year after year. And many of them feature in the G-Class.

They help to detect and control critical situations on and off the road in plenty of time. And they include numerous pre-crash preventive protection measures. Should an accident occur nevertheless, a whole host of passive safety features can be activated, so you can sit back and relax: with a G-Class the focus is on making every drive an experience to remember - for all the right reasons.

It's good to have a team you can rely on

Safety-enhancing electronic assistance systems

When you take the wheel of a G-Class, you have already delegated some of the key tasks, thanks to a whole host of electronic aids which can be activated immediately in critical situations.

If the control unit in the G-Class detects a risk of the vehicle skidding, for example, the Electronic Stability Program ESP® springs into action immediately by reducing the engine torque, applying the brakes at one or more wheels and thus helping to stabilise the vehicle. If emergency braking is detected, Brake Assist (BAS) builds up the maximum braking pressure within fractions of a second, while the modified anti-lock braking system (ABS) developed specifically for the G-Class helps to ensure that the vehicle remains steerable and that its directional stability is maintained in an emergency. These electronic aids, together with the passive safety features on board, help to protect the occupants of the G-Class.



G-Guard

Special protection against the road's more out-of-the-ordinary dangers

The G-Class special-protection vehicles represent the very highest security standards, without compromising where comfort is concerned. The G-Guard's protective elements are deeply embedded in the body structure at the production stage, helping to ensure comprehensive all-round protection. They include numerous discreet safety details which can protect you in an emergency. Some 80 years of experience in protection technology and ballistics have been incorporated into the concept in close cooperation with international security authorities. In its glazed areas the G-Guard even offers protection levels rated to the highest protection classes VR6 and VR7.

The G-Guard is tested for resistance to projectile penetration in a series of ballistic tests. And it goes without saying that it also passes all the usual Mercedes-Benz quality and safety tests. All the safety components – such as the electronic control systems, the brakes, the chassis and the suspension – have been adapted to take into account the vehicle's heavier weight. So the G-Guard protects you not only in an emergency – but also against the more everyday dangers you might encounter out on the road.



The G-Guard offers mobile protection in extreme situations. It has been tested and certified by internationally recognised authoritative institutions in accordance with the highest ballistic protection classes VR6 and VR7

AMG: absolute motoring genius

The G 55 AMG's powerful engine

AMG. Three magical letters that are synonymous with performance, prestige and passion. Each engine is built by a single, highly experienced specialist whose personal signature on the engine tag vouches for the quality of the powerful 5.5-litre V8 supercharged engine at the heart of your G 55 AMG.

Developing 373 kW, this powerplant accelerates the G 55 AMG from 0 to 100 km/h in 5.5 seconds. The combination of this superlative power delivery and the outstandingly agile handling provides a level of performance that is matched only by the unique sound of the large-displacement V8. And by the AMG high-performance braking system which brings the vehicle to a halt quickly and safely.

The chassis of the G 55 AMG – whose features include extra-taut shock absorbers – has been configured for sporty driving agility without restricting the off-road capability.

G 55 AMG

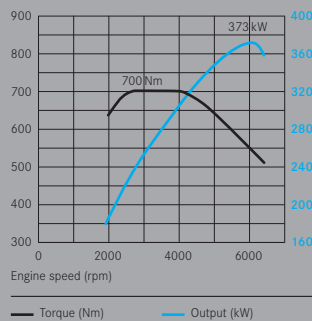

Full power ahead. The impressive torque of 700 Nm is available across a broad engine speed range from 2750 rpm to 4000 rpm



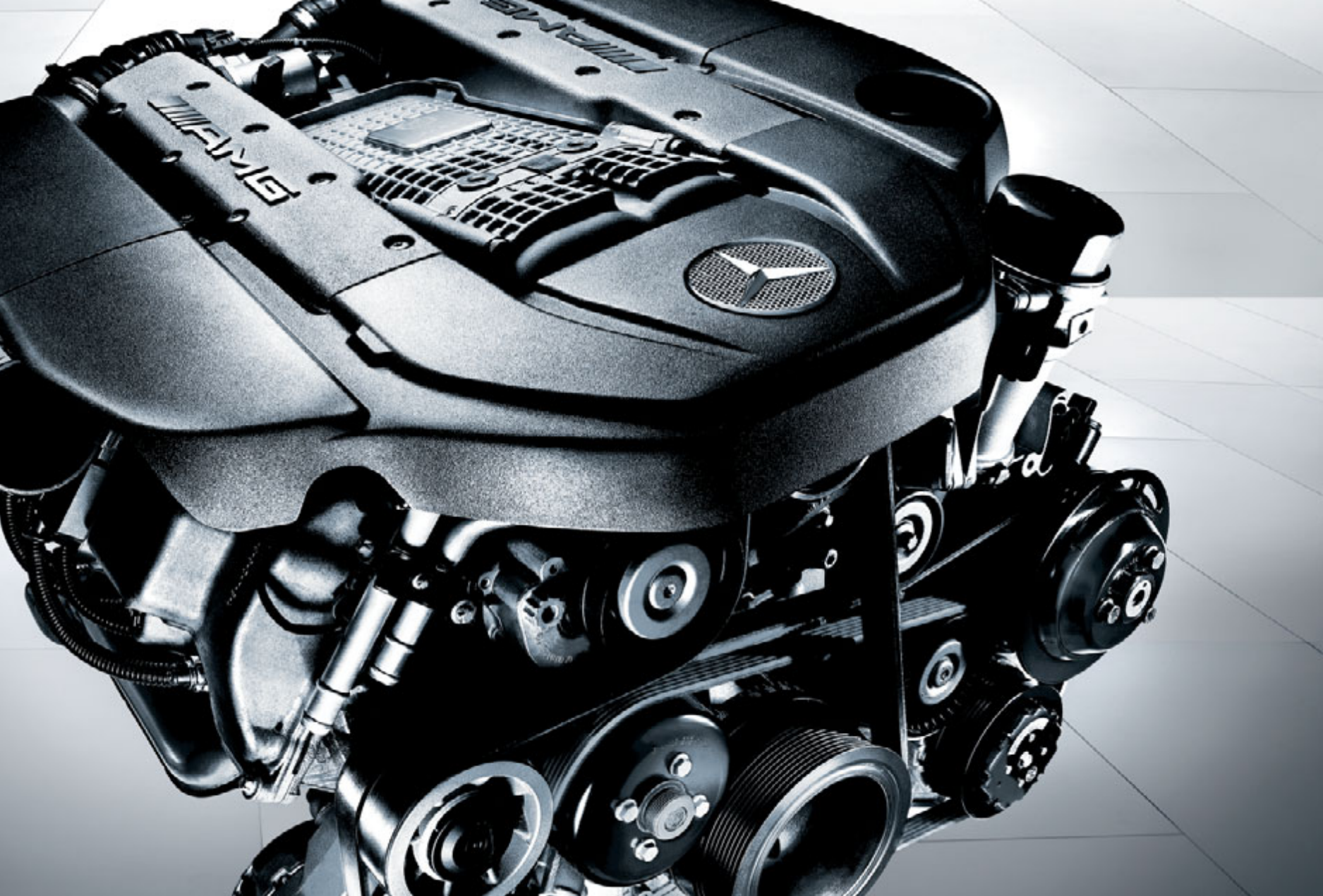

AMG: take it to the limit

The equipment for the G 55 AMG

With its distinctive exterior, the G 55 AMG cuts a fine figure wherever it goes, both on the road or way off it. Its eye-catching design, flamboyant in true AMG fashion, includes 5-spoke light-alloy wheels with 275/55 R 19 tyres, the AMG exhaust system with twin tailpipes on both sides of the vehicle, wheel-arch flaring and the radiator grille with chrome highlights. In store for you in the interior are the Chrome package plus ambient lighting and a leather-covered dashboard.



Exhaust pipes

These features are complemented by an AMG-specific instrument cluster, the G 55 lettering on the selector lever and stainless-steel illuminated door sills, all of which serve to underline the vehicle's sporting ambitions.

The standard-specification designo leather appointments and the designo wood trim give you the opportunity to individualise your G 55 AMG at the highest level.



Instrument cluster









My G-Class



With the G-Class, you're off to an ideal start

Extensive range of equipment options for the G-Class

Perhaps the most impressive aspect of the G-Class's evolution is the level of equipment. That's because what initially started out as a cross-country vehicle for the purists has long been bestowed with all the creature comforts that people have come to expect from a Mercedes-Benz.

Even in standard specification, the G-Class comes with many features which would not be out of place on the options list. These include the THERMATIC automatic climate control which always maintains the precise temperature you set. Entertainment en route is provided by the COMAND APS multimedia system which features a 6-disc DVD changer, a high-resolution 16.5-cm (screen diagonal) display and hard-disc navigation as well as 4 GB of storage for audio files.

The range of optional extras available allows you to create just the G-Class you want. The reversing camera in conjunction with the ultrasonic reversing aid and the garage door opener integrated in the interior mirror are just two of the many other comfort and convenience-enhancing equipment options available for your G-Class.

No darkness, only light

The G-Class lighting concept

The distinctive face of the G-Class is characterised by the radiator grille divided up by 3 louvres. The design boasts clean-cut surfaces and straight lines. The hallmark circular headlamps have always provided a striking contrast to this. Featuring state-of-the-art bi-xenon technology, they illuminate a wide area of the road brightly, enabling you to see dangers and obstacles more clearly and well in advance. Additional front fog

lamps with an integrated cornering light function light up the road immediately in front of the vehicle and illuminate bends.

The G-Class also sets a brilliant example at the rear with an impressive light system including oval tail lights with a sophisticated LED look and the hallmark rectangular lighting units.

The exterior mirrors round off the lighting concept, with standard features including integrated indicator lamps and front area lighting. They are electrically adjustable and heated. What's more, the exterior mirror on the driver's side is automatically dimming, assuring you a clear view of other traffic at all times.



Exterior mirror



Bi-xenon headlamp



Tail light



Inner values matter to the G-Class

The interior: cleverly thought-out equipment and appointments coupled with timeless design

Clear, puristic lines lend the exterior of the G-Class its distinctive appearance. And there is a natural continuation of this design philosophy in the classically modern interior.

Beneath the pristine surface, however, lies state-of-the-art Mercedes-Benz technology: from the multifunction steering wheel to the

sophisticated hard-disc navigation system, the latter forming part of the COMAND APS multimedia system which also offers 4 GB of storage for audio files as well as a 6-disc DVD changer and a high-resolution display with a 16.5-cm screen diagonal. As an option, the long-wheel-base Station Wagon can be equipped with the Harman Kardon® Logic 7® surround sound

system with an output of 450 watts, 12 loudspeakers and Dolby 5.1/DTS.

It's not just the technical equipment that displays the inner values of the G-Class. So do the stylish fine-wood and chrome trim elements that give the passenger compartment the perfect finishing touches.



COMAND APS



Door sill panel



Differential lock buttons

Everything in the G-Class can be controlled simply and intuitively: from the exterior mirrors to the central locking. This is not only practical and convenient, it also enhances safety at critical moments.

Clear lettering and functional controls quickly enable drivers to familiarise themselves with the G-Class – the automatic climate control system, for example, is extremely easy to use.

The standard equipment package for the G-Class also provides for infinitely variable adjustment and storing of the seat, head-restraint, steering-wheel and exterior-mirror positions for up to three people. One press of a button is all it takes for the G-Class to find your preferred settings: just one of many ways to personalise your G-Class.



Control panel for air conditioning



Memory function

Leaves its mark where few others dare to tread

Reassuring: wheels with tyre pressure monitoring system

As well as transferring lateral forces, driving power and braking power to the road, the G-Class wheels also have to perform when there are no roads at all.

All models are available with an integral tyre pressure monitoring system as an optional extra. The electronic system checks the tyre pressure constantly while the vehicle is being driven and immediately informs the driver of any detected pressure loss.



5-spoke light-alloy wheels with 275/55 R 19 tyres, painted in titanium grey (standard for G 55 AMG)

Reveal a new side of your G-Class

The stylish light-alloy wheels for the G-Class

We can't reinvent the wheel. But that doesn't stop us from improving upon it. Our selection of light-alloy wheels is designed to further boost the appeal of your G-Class.

The standard-fit wheels feature a dynamic 5-spoke design. In addition, 6-spoke light-alloy wheels with a high-shine finish are available as optional extras for these models.

The light-alloy wheels painted in titanium grey are exclusively available for the G 55 AMG. Their striking design is the all-round embodiment of stylishness.



5-spoke light-alloy wheels with 265/70 R 16 tyres
(standard for G 350 BlueTEC)



5-twin-spoke light-alloy wheels with 265/60 R 18 tyres
(standard for G 500, optional extra for G 350 BlueTEC)



6-spoke light-alloy wheels with 265/60 R 18 tyres
(optional extra for G 350 BlueTEC/G 500)

Exceptional seats for an even more exceptional driving experience

The multicontour seat in the G-Class

The G-Class with heated multicontour seats provides an outstanding level of comfort which is sure to be appreciated on long as well as short trips. The comfortable multicontour seats are ergonomically shaped and individually adjustable for firmness. Several air chambers under the upholstery material allow you to adjust the multicontour seats precisely according to your own preferences.

The chambers in the lumbar area, backrest side bolsters and front seat cushion can be inflated to provide you with excellent stability and lateral support on almost any trip. To add that finishing touch in seating comfort, the multicontour seats for the driver and front passenger in the G-Class are climatised.





Competition for the night sky

Ambient lighting from Mercedes-Benz

With this particularly pleasant type of interior lighting from Mercedes-Benz you'll find night-time journeys all the more enjoyable. What's more, it gives added emphasis to the high-quality interior design of your G-Class.

The dimmable ambient lighting is part of the standard specification for the G 55 AMG, and it is available as an optional extra for the G 350 BlueTEC and the G 500. In addition to the instrument lighting, fibre optic cables in the door side trim panels and lamps in the footwell, door openers and stowage tray produce an especially cosy atmosphere. Together with the instrument cluster the brightness of the ambient lighting can be variably adjusted. The ambient lighting even goes out of its way to give you a warm welcome: to make getting into the vehicle even more of a pleasure, the footwell is illuminated to the maximum extent when the front doors are opened. As soon as they are closed, the light is dimmed again.



Illuminated door opener

Standard equipment (selection)

12-volt sockets in front passenger footwell and rear or (Station Wagon) load compartment
4 belt tensioners
7G-TRONIC automatic transmission/5-speed automatic transmission in the G 55 AMG
Airbags for driver and front passenger with seat occupancy sensor, long-wheelbase Station Wagon also features windowbags
Ambient lighting ^{1,4}
AMG light-alloy wheels, 275 / 55 R 19, painted titanium grey ¹
Anti-lock braking system (ABS) and Brake Assist (BAS)
Armrest betw. front seats w. integrated stowage compartment and compartment w. sliding cover
ASSYST service interval indicator
Bi-xenon headlamps with automatic range adjustment and headlamp cleaning system
Cabriolet soft-top, black, electrohydraulically operated
Central locking with infrared radio remote control and interior switch
Chrome package ^{1,4}
COMAND APS multimedia system
Cruise control with variable speed limiter
Differential locks (transfer case front and rear axle)
Door sill panels in stainless steel with "Mercedes-Benz" lettering
Electrically adjustable front seats with memory for seats, exterior mirrors and steering wheel
Electronic brake force distribution (EBD)
Electronic Stability Program (ESP®)
Electronic traction system for all-wheel drive (4ETS)
Exterior mirrors with integrated turn indicators and front area lighting, electrically adjustable and heated – driver's mirror automatically dimming

Front fog lamps with integral cornering light function
"G-Line" fine wood trim in anthracite ² /burr walnut ^{3,4} /designo ¹ , centre console, dashboard and shift gate cover
Headlamp Assist
Heated seats (driver/front passenger)
ISOFIX child seat attachment points
Leather upholstery ^{3,4} , designo leather upholstery ¹ (door panelling in ruffled leather)
Light-alloy wheels, 265/70 R 16 ² ; 265/60 R 18 ^{3,4}
Load retainers in luggage compartment
Low-range gear reduction (electrically selectable while on the move)
Multifunction steering wheel and selector lever in leather ² , multifunction steering wheel and selector lever in leather/wood ^{1,3,4}
Permanent all-wheel drive with differential
Power windows
Rain sensor
Seat belts, 3-point design (five) in long-wheelbase Station Wagon
Seat belts, 3-point design (four) in short-wheelbase Station Wagon and Cabriolet
Split-folding rear bench seat (1/2 : 1/2) for short-wheelbase Station Wagon and Cabriolet
Split-folding rear bench seat (1/3 : 2/3) for long-wheelbase Station Wagon
Steering column electrically adjustable, automatic steering wheel adjustment for easy entry/exit
THERMATIC automatic climate control including dust and pollen filter
Trailer socket, 13-pin

¹ Standard for G 55 AMG² Standard for G 350 BlueTEC³ Standard for G 500⁴ Standard for "BA3 Final Edition" special version of short-wheelbase Station Wagon

Optional extras (selection)	Cabriolet wheelbase 2400	G 350 BlueTEC	G 500	"BA3 Final Edition" Station Wagon with short wheelbase 2400	G 350 BlueTEC	G 500	Long Station Wagon wheelbase 2850	G 350 BlueTEC	G 500	G 55 AMG
Ball-head trailer coupling		●	●		□	□		●	● ¹	●
Convenience Telephony in the armrest		●	●		□	□		●	●	●
Exterior Stainless Steel package (running boards at left and right and spare-wheel cover with 3D Mercedes star in stainless steel)		●	●		□	□		●	● ¹	□
Harman Kardon® Logic 7® surround sound system		-	-		-	-		●	● ¹	●
Rear Seat Entertainment System (17.8-cm monitors with integrated DVD player on the back of the front-seat head restraints, USB port, SD card slot, AV connection for iPod® or games consoles, two sets of infrared headphones, infrared remote control)		-	-		-	-		●	●	●
NECK-PRO luxury front head restraints, crash - responsive		●	●		-	-		●	● ¹	●
Power-operated sliding sunroof		-	-		□	□		●	●	●
Reversing camera ²		-	-		-	-		●	●	●
Seat Comfort package ³ (front multicontour climatized seats)		●	●		□	□		●	●	●
Ultrasonic reversing aid		●	●		□	□		●	●	●

¹ Included in special "Edition Select" model, Code ZQ6

² Only in conjunction with ultrasonic reversing aid, Code J44

³ Only in conjunction with leather upholstery, Code SP3/SP4 or SP5, or designo leather



Rear Seat Entertainment System

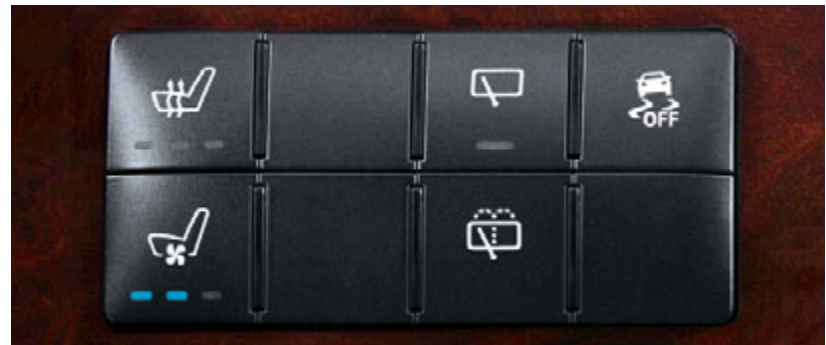

Climatized seats

● Available at extra cost □ Standard - Not available

The last of its kind with a unique range of equipment

“BA3 Final Edition”, the short-wheelbase G-Class Station Wagon

A final flourish worthy of a legend: the limited-edition G-Class “BA3 Final Edition”. The Station Wagon model will only be available until June 2012 – afterwards you will probably only encounter it off the beaten track. As a farewell gesture, this consummate hill-climber among cross-country vehicles is demonstrating its sporty character more emphatically than ever. It finds expression in features such as the Stainless Steel exterior package with running boards at left and right and the spare wheel cover with a three-dimensional Mercedes-Benz star.

The exclusive AMG wheel-arch flaring in metallic vehicle colour as well as the AMG 3-louvre radiator grille add even greater emphasis. 5-twin-spoke light-alloy wheels ensure that the “BA3 Final Edition” can make sure-footed progress through challenging terrain. In fact there’s probably only one thing that can stop it: a beautiful view.







G 31

BLUETEC

S 0X 1123

Keeps going where navigation systems stop

Fine wood and paintwork, high-quality leather, chrome and stainless steel – no matter how far you stray from civilisation in the “BA3 Final Edition”, there is always a thoroughly civilised environment on board. Equipped with the Interior Chrome package and the Exterior Stainless Steel package, it maintains a decidedly sporty profile while the Seat Comfort package with climatised multicontour seats and black leather upholstery is both stylish and supportive. And if the world outside is less than inspiring, you can always admire the burr walnut wood trim as well as the wood/leather steering wheel and selector lever.

Another eye-catching feature is the ambient lighting system which bathes the interior in a pleasant light – just the thing when your view of a spectacular sunset is blocked by clouds. But you can always count on the Convenience Telephony system in the armrest which includes a universal interface and an exterior aerial for optimum reception. So even when your G-Class takes you far off the beaten track, you can still stay in touch – if you want to.



For the urban jungle

The G-Class "Edition Select"

When the landscape changes from boulders to boulevards, the G-Class "Edition Select" is the perfect choice. This special model gives the powerful charisma of the Station Wagon a new dimension in the form of a distinctive two-colour concept. The two-tone exterior paint finish featuring obsidian black metallic as the contrast colour on the bumpers, wheel-arch flaring and exterior mirrors steals the scene in every situation and is available in three colour combinations: designo mystic white, palladium silver and thulite red, which highlights the contrasting colour even more strongly. Never before has the G-Class made such a striking visual statement. Edition Select offers a more discreet alternative: it is also available in single-tone obsidian black metallic.







Who says the city's no place to see natural phenomena?

Opposites attract, it is said. And in the case of the G-Class "Edition Select", they attract attention. The dominant colour concept also underlines the special features of the vehicle: the wheel-arch flaring is highlighted in obsidian black metallic, for example, while the 5-twin-spoke light-alloy wheels are also painted in black. Other visual highlights include the AMG-design sports exhaust system, the underride guard and the Exterior Stainless Steel package with a spare-wheel cover embellished with a three-dimensional Mercedes star. All these features of the "Edition Select" enhance the distinctive, sporty character of the G-Class with a particularly expressive design treatment.







The freedom to go anywhere. The feeling that you've already arrived

The interior of the "Edition Select"

Home is where the heart is – but in this case there is no postal address. The dominant colour concept of the G-Class "Edition Select" is continued consistently to the same high standard inside the vehicle. Elegance is the keynote of the two-tone design: leather upholstery in porcelain and black. The porcelain coloured ruffled leather of the door centre panels is framed by black door lining elements while the dashboard is finished in black leather with contrasting pebble-coloured decorative stitching. Stainless steel door sill panels illuminated in white welcome the driver and passengers aboard. Further highlights are created by the Chrome package – on the loudspeakers in the front doors, for example. The "Edition Select" badge on the stowage compartment is the finishing touch which vouches for the high standard of the interior design treatment.

The five best seats in the house. And you choose the entertainment programme

There are sound studios which are less well-equipped than this: designo leather and designo wood trim elements in black piano lacquer create an exclusive environment while the Harman Kardon® surround sound system delivers sound of the highest quality. At the same time, the ambient lighting bathes the interior in a pleasant glow. Your arms are supported comfortably on the door handles, armrests or the hand brake lever, all of which are finished in black leather and completed to perfection by pebble-coloured decorative stitching which creates an attractive contrast. Relax and rest the back of your head on the crash-responsive NECK-PRO luxury head restraint as you slowly close your eyes. In fact, there's really only one thing more enjoyable than listening to a concert in a parked G-Class: driving it.









The irresistible beauty of a beautifully resistant finish

The clearcoat with greater scratch resistance

1934. The first “Silver Arrow” must be the only Mercedes-Benz ever to have started out in life with less-than-perfect paintwork. When the Mercedes-Benz engineers put the newly developed W 25 racing car on the scales before the Eifel Grand Prix at the Nürburgring in 1934, the car weighed 751 kg – 1 kg over the strict weight limit imposed by the international racing federation. “Well, that takes the shine off things,” mused Mercedes racing manager Alfred Neubauer – then realised he’d just put his finger on the solution. He promptly ordered the engineers to sand down the white paintwork, exposing the silver-coloured aluminium bodywork. This shed the necessary weight and the rest is history: Manfred von Brauchitsch won the race and it wasn’t long before the press were raving about the “Silver Arrows”, as they quickly dubbed them.

Of course, things wouldn’t have been so easy for the team if their car had been sporting the current paintwork developed by Mercedes-Benz. This paint is much tougher than previous clearcoats, with a more durable, more intense sheen. Both the metallic and non-metallic clearcoats are more scratch-resistant and less susceptible to weather and environmental influences, like precipitation, sunlight, fluctuating temperatures, dust or soot.



Who said adventures couldn't be luxurious?

The interior appointment variants for the G-Class

Leather is an elegant, natural material that is durable and easy to look after. It is ideal for everyday use or on long trips. Best of all, it has an attractive look and a soft feel. There is a choice of leather appointments in black, grey or chestnut (optional for the G 350 BlueTEC and standard for the G 500). But whichever one you choose, having seats in leather will clearly emphasise the exclusivity of your G-Class.

The designo leather appointments (standard for the G 55 AMG) impart a particularly luxurious charm to your G-Class. Seats, head restraints and interior trim are available in eleven colour tones, with the door panelling in ruffled designo leather. You can add the finishing touch to the exclusive interior appointments of your G-Class with the roof lining in fine anthracite Alcantara® and a dashboard covered with leather.



Grey leather



Chestnut leather

The G-Class

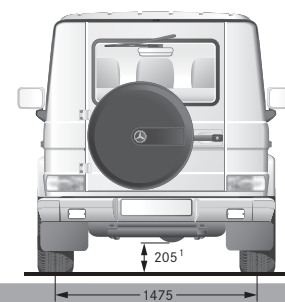
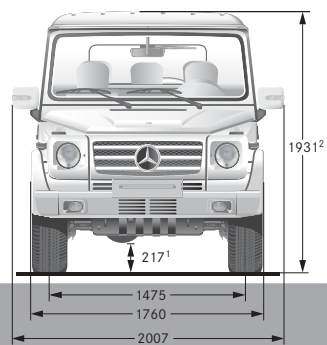
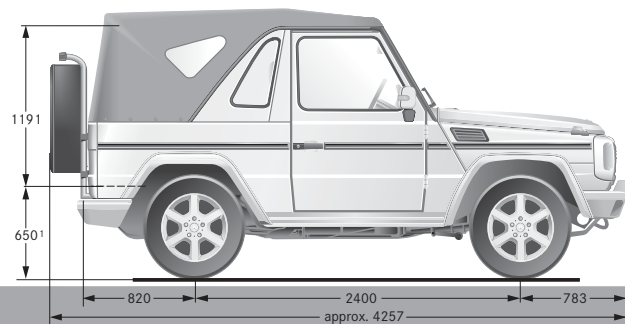
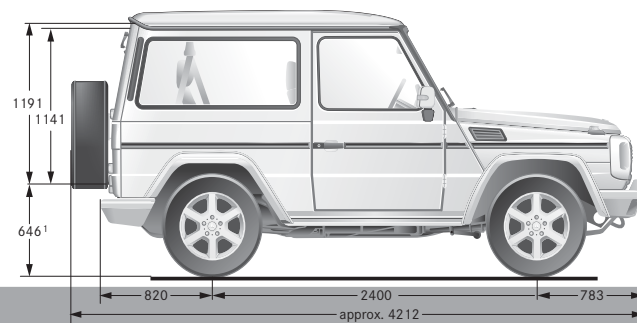
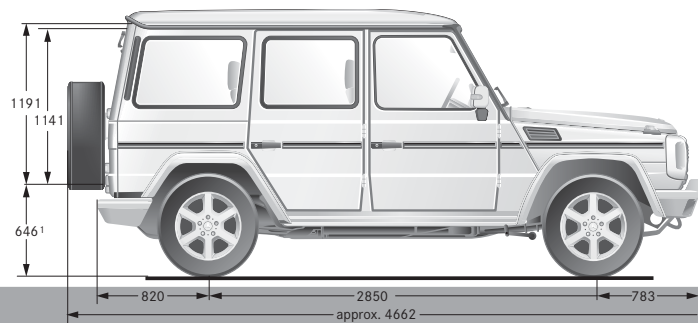

The dimensions shown are mean values (in mm) and apply to standard-specification vehicles carrying three occupants weighing 68 kg each

¹With maximum permissible payload ²Height of cabriolet: 1941 mm

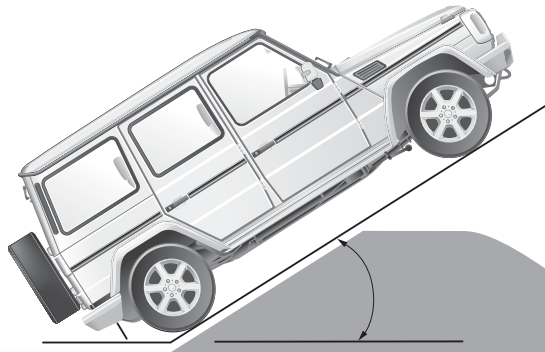

Slope-climbing ability up to 80%, depending on terrain

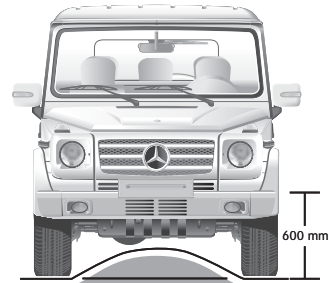

Ground clearance 210 mm
Max fording depth 600 mm



Directionally stable on lateral slopes up to 54%

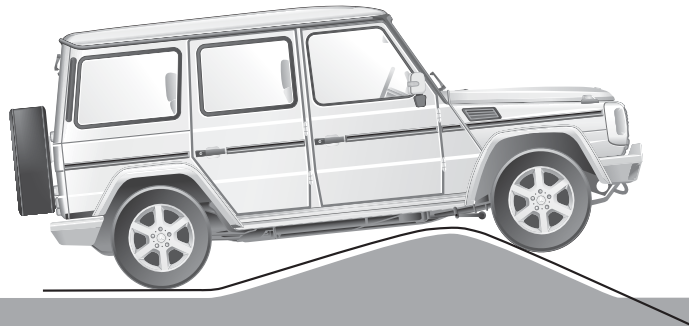

Large ramp angle



Angle of approach 36° / departure 27°

Anyone opting for a Mercedes buys far more than just a car

Mercedes-Benz Museum. 125 years of automotive history in one place – this is what awaits you at the Mercedes-Benz Museum in Stuttgart. Experience the unique excitement and embark upon a thrilling journey through time. Housed inside an architecturally impressive building, over 1500 exhibits on nine levels give you an insight into the unique tradition and powers of innovation of the Mercedes-Benz brand. See the world's first two automobiles in the shape of the Benz Patent-Motorwagen (motor car) and the Daimler motorised carriage – both from the year 1886. Two linked circuits take you from the beginnings of the automobile, past a series of unforgettable classics and on to a glimpse of what the future holds – in an area covering a total of 16,500 square metres. Enjoy the unique brand experience. We look forward to your visit. Further details can be found at www.mercedes-benz-classic.com/museum

MercedesCard. The card is your ticket to the Mercedes-Benz experience. Four times a year, we will send you the Mercedes Magazine, featuring fascinating reports from the world of Mercedes-Benz and articles about our latest vehicles. A MercedesCard also has many other uses too. As a VISA credit card, it is an internationally accepted means of payment. Further benefits are available to provide you with peace of mind, such as insurance packages for your Mercedes and other insurance services for the whole family. You also get free entry to the Mercedes-Benz Museum simply by showing your VISA MercedesCard. Further details can be found at www.mercedes-benz.de/mercedescard¹

Mercedes-Benz Financial Services. Mercedes-Benz stands for quality, innovation and safety – and the same applies to Mercedes-Benz Financial Services. Our innovative leasing and financing products are tailored to your financial needs and means, making it easy for you to secure the keys to your dream car. Once you are on the road, our insurance products offer you comprehensive protection on every trip. Finally, our service products ensure that your car is always in tip-top condition whilst keeping costs transparent and easily manageable. For a detailed quotation, please contact your Mercedes-Benz dealer, who will be glad to go through the latest financial services and terms and conditions with you.

¹ Information about the MercedesCard in Austria and Switzerland can be found on the Mercedes-Benz websites for these countries

Mercedes-Benz mobility. Your new car comes complete with the promise of feeling safe on the road, but if you should ever need assistance, then Mercedes-Benz Service24h is there to help. Just call the freephone service hotline on 00800 1 777 7777². The newly integrated telematics service, Mercedes-Benz Contact³, is even more customer friendly: a touch of a button is all it takes to contact the Mercedes-Benz customer centre. If you wish, the relevant vehicle and position-related data can be transmitted at the same time, thereby allowing the centre to react quickly and provide rapid on-the-spot assistance. Also standard with your new car at no extra charge is the Mercedes-Benz Mobilo⁴ mobility package. Whether you have lost your key, had a breakdown which cannot be repaired immediately or suffered damage to the vehicle due to an accident or vandalism, Mobilo is there to help you reach your destination – anywhere in Europe. Whatever your problem, one thing is certain: you will soon be able to resume your journey.

Service packages. Vehicle-specific services allow you to put together an individual package for your Mercedes, including long-term protection against unforeseeable repair costs and high-quality servicing with genuine Mercedes-Benz parts. You can also count on the extensive network of Mercedes-Benz workshops, where you will receive the usual high standard of service for your Mercedes at a predictable, fixed price. Please ask your Mercedes-Benz dealer for further details.

² Alternative: +49 69 95 30 72 77

³ Requires a factory-fitted radio linked up to a switched-on mobile phone

⁴ When the warranty has expired Mobilo can be extended by another year for a maximum of 30 years, provided that regular maintenance is carried out by your Mercedes-Benz service partner

Time for another enriching experience

A Mercedes-Benz is most at home on the road. This is the only way to experience the effortlessly superior driving feel that lends every Mercedes model its inimitable class. Feel the power of efficient engines with low fuel consumption and precise steering, designed to put you right in the mood for driving. And experience what true comfort really is. The unique feeling of driving a Mercedes cannot be put into words, however. Which is precisely why we'd like to invite you to take a test drive. Your Mercedes-Benz dealer will be happy to make all the necessary arrangements for you. Simply visit www.mercedes-benz.com to locate the nearest Mercedes-Benz dealer in your country or region. We look forward to seeing you.

The website also offers an interactive tour, enabling you to take a closer look at your desired model. These informative clips are the ideal way to acquaint yourself with your dream car. You can view key functions in detail, gain an insight into the car's inner workings or look at the benefits of each model. For further details, visit www.mercedes-benz.de/owners-manual

Now your mobile phone acts as a gateway to the whole Mercedes-Benz world. In addition to an overview of all passenger car models, there are insights into the entire brand world, not to mention a wealth of entertainment offers and direct links to a range of services at www.mercedes.mobi



	Non-metallic paints		Metallic paints										
	black	calcite white	chromite black	obsidian black	periclas green	lazurite blue	tanzanite blue	flint grey	peridot brown	thulite red	iridium silver	palladium silver	sandine beige
G 350 BlueTEC fabric, standard specification													
black	●	●	●	●	●	●	●	●	●	●	●	●	●
G 350 BlueTEC leather, optional extra													
black	●	●	●	●	●	●	●	●	●	●	●	●	●
grey	●	●	●	●	●	●	●	○	●	●	○	○	
chestnut	●	●	●	●	○	○	●	○	●	○	●	●	●
G 500 leather, standard specification													
black	△	△	●	●	●	●	●	●	●	●	●	●	●
grey	△	△	●	●	●	●	●	○	●	●	○	○	
chestnut	△	△	●	●	○	○	●	○	●	○	●	●	●

● Recommended

○ Possible

△ Not possible

Roof lining
(long-wheelbase Station Wagon)



anthracite Alcantara[®] 3,4



grey velour^{1,2}

Upholstery

Fabric¹



black

Leather^{2,5}

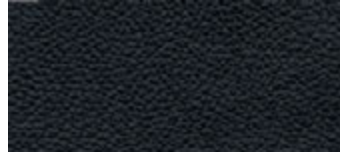

black



grey

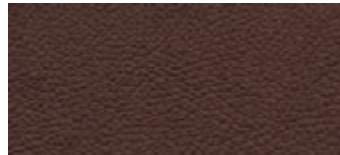

chestnut

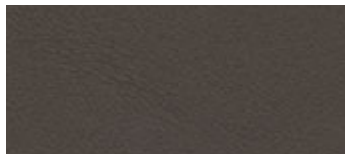
designo leather^{3,4}

ZF2 designo corteccia



ZF5 designo classic red



ZJ5 designo chablis



ZK8 designo mystic red

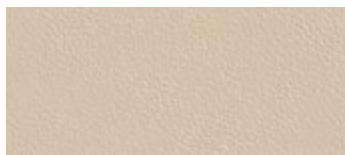

ZF3 designo porcelain



ZF7 designo black



ZK6 designo sand



ZL1 designo mauritius blue



ZF4 designo marron

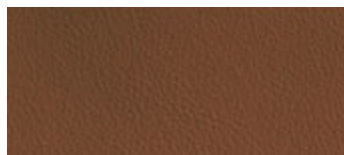

ZH2 designo light brown

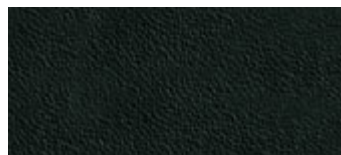

ZK7 designo graphite green

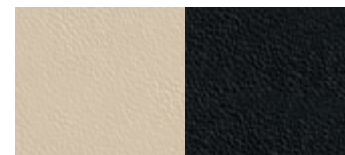
ZF3 designo porcelain/ZF7 black⁶

¹ Standard for G 350 BlueTEC

² Standard for G 500 and special "BA3 Final Edition" model

³ Optional extra for G 350 BlueTEC and G 500 and included in special "Edition Select" model, Code ZQ6

⁴ Standard for G 55 AMG

⁵ Optional extra for G 350 BlueTEC

⁶ Included exclusively in special "Edition Select" model, Code ZQ6. Code ZF7 can be selected as an alternative

Wood trim

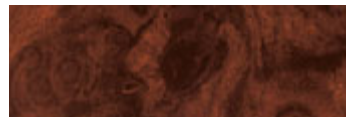
High-gloss anthracite "G-Line" wood¹High-gloss brown burr walnut wood^{2,3}

Wood/leather steering wheel and selector lever

VL1 high-gloss brown burr walnut wood^{2,3}

designo trim

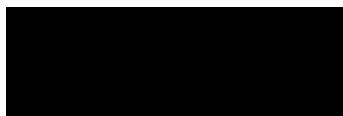
ZG2 designo black piano lacquer wood^{4,5,6}

designo wood/leather steering wheel and selector lever

ZG3 designo black piano lacquer wood^{4,5,6}

designo trim

ZM0 designo brown natural maple grain wood^{4,5}

designo wood/leather steering wheel and selector lever

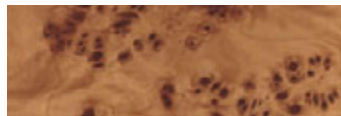
ZM9 designo brown natural maple grain wood^{4,5}ZM5 designo anthracite poplar wood^{4,5}ZM5 designo anthracite poplar wood^{4,5}ZM5 designo light brown natural poplar wood^{4,5}ZM6 designo light brown natural poplar wood^{4,5}

ZN0 designo natural matt oak grain wood

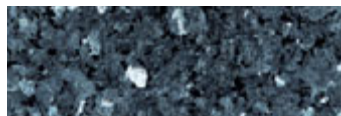

ZR0 designo natural matt oak grain wood

ZG4 designo labrador blue pearl stone⁷ZG3 designo black piano lacquer wood⁷¹ Standard for G 350 BlueTEC² Standard for G 500 and special "BA3 Final Edition" model³ Optional extra for G 350 BlueTEC⁵ Standard for G 55 AMG⁶ Included in special "Edition Select" model, Code ZQ6⁷ Optional extra for G 350 BlueTEC, G 500 and G 55 AMG⁴ Optional extra for G 350 BlueTEC and G 500

Non-metallic paints



040 black



650 calcite white

Metallic paints



112 chromite black



197 obsidian black



300 periclase green



349 lazurite blue



359 tanzanite blue



368 flint grey



474 peridot brown

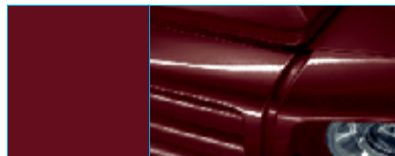

541 thulite red

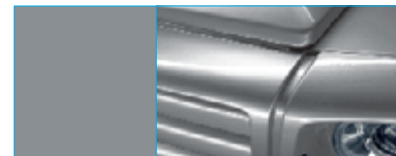

775 iridium silver

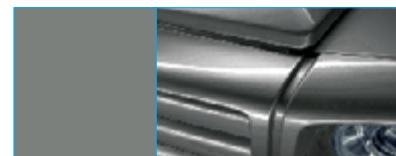

792 palladium silver



798 sanidine beige

designo paints



033 designo mocha black



041 designo graphite



046 designo platinum black

designo mystic paints



032 designo mystic blue



037 designo mystic red

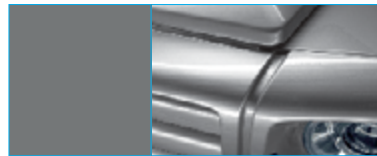

052 designo mystic brown

designo magno paints

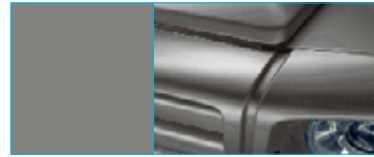

051 designo magno platinum

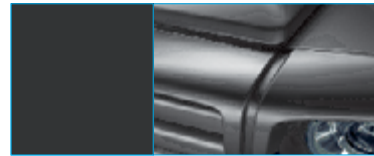

056 designo magno night black

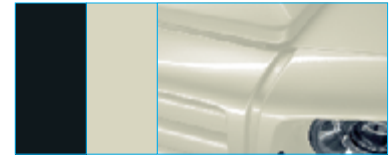
“Edition Select” paintwork, two-tone¹

197 obsidian black/048 designo mystic white

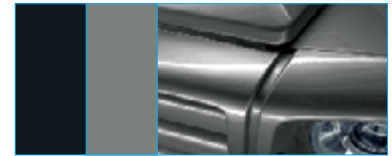

197 obsidian black/792 palladium silver



197 obsidian black/541 thulite red



197 obsidian black/197 obsidian black

¹ Choice of body colours, detachable body components in obsidian black

	G 350 BlueTEC		G 500		G 55 AMG
No. of cylinders/arrangement	6/V		8/V		8/V
Transmission, automatic	7G-TRONIC		7G-TRONIC		5-speed
Bore/stroke (mm)	83.0/92.0		98.0/90.5		97.0/92.0
Total displacement (cc)	2987		5461		5439
Rated output ¹ kW (hp) at rpm	155 (211)/3400		285 (387)/6000		373 (507)/6100
Rated torque ¹ (Nm at rpm)	540/1600–2400		530/2800–4800		700/2750–4000
Top speed, approx. (km/h)	175		210 ²		210 ²
Tyre size	265/70 R 16		265/60 R 18		275/55 R 19
Fuel consumption ³ (l/100 km) urban/extra-urban/combined	Diesel 13.6/9.8/11.2		Premium petrol 20.0/11.9/14.9		Premium petrol 21.6/12.6/15.9
Tank capacity (l)	96		96		96
CO ₂ emissions ³ (g/km) combined	295		348		372
Emissions standard	Euro 5		Euro 5		Euro 5
	Cabriolet	LWB Station Wagon/“BA3 Final Edition”	Cabriolet	LWB Station Wagon/“BA3 Final Edition”	LWB Station Wagon
Acceleration 0–100 km/h (s)	8.8	9.1/8.8	5.9	6.1/5.9	5.5
Kerb weight ⁴ (kg)	2320	2590/2475	2335	2530/2360	2580
Payload (kg)	530	610/375	515	670/490	620
Permissible gross vehicle weight (kg)	2850	3200/2850	2850	3200/2850	3200
Towing capacity unbraked (kg)	750	750/750	750	750/750	750
Towing cap. braked incl. drawbar load, 115 kg short wheelbase	2850 ⁵	–/2850 ⁵	2850 ⁵	–/2850 ⁵	–
140 kg long wheelbase	–	3500 ⁶ /–	–	3500 ⁶ /–	3500 ⁶
Gross combination weight (kg)	5700	6700/5700	5700	6700/5700	6700

¹ Figures according to Directive 80/1269/EEC in the currently applicable version ² Electronically governed ³ The figures shown were obtained in accordance with the prescribed measuring process (Directive 80/1268/EEC in the currently applicable version). The figures are not based on an individual model and do not constitute part of the product offer; they are provided solely for purposes of comparison between different vehicle models ⁴ Figures according to Directive 92/21/EC, version 95/48/EC (kerb weight with fuel tank 90% full, driver, 68 kg, and luggage, 7 kg) for standard-specification vehicles. Optional extras and accessories will generally increase this figure and reduce the payload capacity accordingly ⁵ Statutory requirements met for 12% gradient at 2850 kg ⁶ Statutory requirements met for 12% gradient at 3500 kg

Take-back of end-of-life vehicles. Coming full circle. At the end of its long life, you can return your G-Class to us for environment-friendly disposal in accordance with the EC End-Of-Life Vehicle Directive¹. But that day lies a long way off.

¹Applies in accordance with national regulations to vehicles up to 3.5 tonnes gross weight. Mercedes-Benz passenger cars have met the statutory regulations governing the suitability of their design for reuse and recycling for a number of years now. A network of vehicle take-back depots and dismantlers has been established which will process your vehicle in an environment-friendly manner. The ways in which both vehicles and parts can be recovered are subject to ongoing development and improvement. Consequently, the G-Class will be able to comply with any future increases in the recycling quota within the stipulated time limits. For further information, please call 00800 1 777 7777

Please note: changes may have been made to the product since this brochure went to press (29.04.2011). The manufacturer reserves the right to make changes to the design, form, colour and specification during the delivery period, provided these changes, while taking into account the interests of the vendor, can be deemed reasonable with respect to the purchaser. Where the vendor or the manufacturer uses symbols or numbers to describe an order or the subject of an order, no rights may be derived solely from these. The illustrations may show accessories and items of optional equipment which are not part of standard specification. Colours may differ slightly from those shown, owing to the limitations of the printing process. This brochure is distributed internationally. It provides a general indication of the range of models, features, optional extras, colours and/or services available in various countries. Some of the models, features, optional extras, colours and/or services may not be available in your country, or may only be available in a different specification. Additionally some models, features, optional extras, colours and/or services may only be available in combination with others. For current and more specific information in relation to the range of models, features, optional extras, colours and/or services available in your country, and their pricing, you should contact your nearest authorised Mercedes-Benz Passenger Car Dealer. www.mercedes-benz.com