

This Brochure is prepared by Daimler AG and it predominantly reflects the capabilities and performance of vehicles sold in Europe. Some characteristics, capabilities, performance features and optional extras (e.g. towing systems) may not be available or may not apply in Australia or under Australian conditions. The information in this Brochure is therefore indicative, illustrative and provided only for guidance and should not be relied on. To obtain current and accurate information on a vehicle and any options applicable to Australia, contact your local authorised Mercedes-Benz dealer.



Mercedes-Benz

The R-Class



Mercedes-Benz

Building a generously dimensioned car is one thing. But combining legendary status with dynamism of a calibre you would not necessarily expect from a car with these proportions is the smallest kingdom in the world – or the most spacious car we have ever seen. After all, your real riches are not to be found in your bank account – they are on the road. There is room for everything in the R-Class – except shade, that is. You know exactly how it should be: a car that listens only to *your* wishes. Modesty is a virtue, but not when it comes to glory. Building a generously dimensioned car is one thing. But combining legendary status with dynamism of a calibre you would not necessarily expect from a car with these proportions is your private jet for the road: up to three rows of seats, plenty of legroom, and space for the seats. **A king amongst family cars.** Allow us to introduce: the smallest kingdom in the world. After all, your real riches are not to be found in your bank account – they are on the road.



The R-Class represents the very finest virtues. A love of the family, for example: no other passenger car from Mercedes-Benz gives your nearest and dearest this much space. The standards of uncompromising quality you demand are evident in the finest workmanship of beautiful materials. The R-Class assumes responsibility with its assistance systems. It can

increase the safety of the occupants and show consideration for other road users. Numerous BlueEFFICIENCY measures help to ease the burden on the environment. The R-Class. A car beyond reproach. And quite rightly a king amongst family cars.

At a glance | from page 4 Insight | from page 28

Featured models:

R 350 BlueTEC 4MATIC | palladium silver metallic | Cover,
from page 2

5-twin spoke light-alloy wheels, Alcantara®/ARTICO man-made leather in alpaca grey, dark aluminium trim with longitudinal grain

R 350 CDI 4MATIC | obsidian black metallic | from page 17
10-spoke light-alloy wheels, black/almond beige leather, high-gloss brown burr walnut wood trim with chrome panels

The illustrations may show accessories and optional extras which are not part of the standard specification.

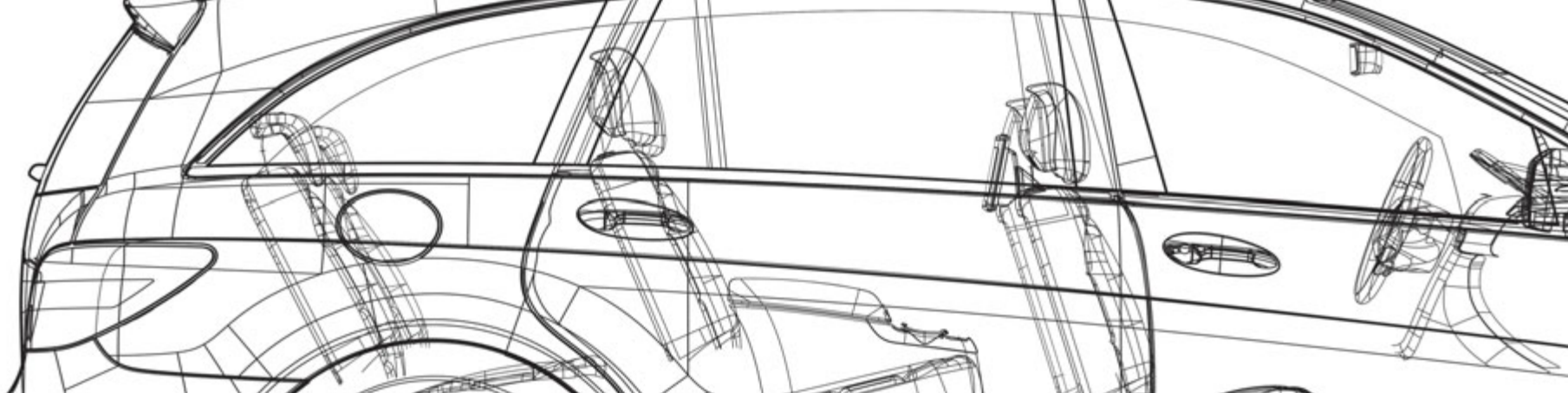

Room for leading-edge technology:

BlueEFFICIENCY, diesel and petrol engines, transmissions, chassis and suspension.

Drive system & chassis | from page 36

Safety for the whole family:

the latest active- and passive-safety technologies.

Safety | from page 46

First-class travel: flexible space concept and comfort for up to seven people, multimedia and assistance systems, climate control and seats.

Comfort | from page 50

Big is beautiful: find out all about the long-wheelbase version of the R-Class.

Model variant | from page 60

More room for individuality: equipment, packages, upholstery and trim, wheels and genuine accessories.

Equipment & appointments | from page 62

Service writ large: everything about the MercedesCard, Mercedes-Benz Financial Services, Mercedes-Benz mobility, Mercedes-Benz Museum, test drive, Interactive Owner's Manual, mobile internet, service packages and repair following an accident.

Services | from page 80

Big on detail: dimensions, paintwork and technical data.

Facts & colours | from page 82



A kingdom with seven thrones

Allow us to introduce: the smallest kingdom in the world – or the most spacious car we’ve ever built. The R-Class fulfils discerning requirements regarding space, comfort and quality for up to seven people. Because *noblesse oblige* – as does the name Mercedes-Benz.



The R-Class takes care of your dearest valuables, its generous dimensions playing but a small part. If you wish, it can monitor the blind spot, as well as helping you to maintain the desired distance from the vehicle in front. After all, your real riches are not to be found in your bank account – they're on the back seat.





Built for your most treasured possession.
Your family

His Majesty in fine robes





The R-Class displays a regal stance with its wide, upright radiator grille. The charismatic headlamps are focused firmly ahead. With fine beltline trim strips and elegant door handles it sets a shining example in chrome. It's evident in every detail: the R-Class comes from good stock.

R the Great

An extra measure of greatness. The long-wheelbase version of the R-Class offers even more room in the second and third rows. Even the sliding sunroof steps up a size: as an option, you can have a panoramic sliding sunroof that stretches over virtually the entire area of the roof. There's room for everything in the R-Class.







Your wish is its command

You can do as you please here to your heart's content. The interior concept of the R-Class is exceptionally flexible. Each rear seat can be folded down individually. And you can even create a flat load surface should you ever need it. This is precisely how it should be: a car that listens only to your wishes.







You reign supreme in
the front. Free rein for
the children in the rear







Modesty is a virtue displayed by the R-Class, too. At least where consumption is concerned: a low drag coefficient and numerous BlueEFFICIENCY measures all do their bit. Efficient mobility is our crowning glory.

Building a generously dimensioned car is one thing. But combining legendary standards of comfort with high agility is not something very many manage at this level. The R-Class impresses with dynamism of a calibre you wouldn't necessarily expect of a car with these proportions. But a Mercedes is the exception.



There are palaces aplenty.
But only a select few have four wheels





You like travelling in a more distinguished fashion? The R-Class is your private jet for the road: up to three rows of seats, plenty of legroom, armrests, cup holders, two optional screens for the second seat row. Plus an individually adjustable air conditioning system – as an option in the rear, too. In fact, the only thing we haven't included is numbering for the seats.

The first Mercedes that's
every inch a king

Why not simply take your entire
entourage with you?











“Papa Benz”, as he was lovingly and respectfully known to many of his contemporaries, was not just the father of the motor car – he was also the proud father of five children. They always supported him in any way they could. The eldest, for instance, accompanied him on those very first test drives – not in the car, though. Off Eugen would go, petrol can in hand, whenever the fuel ran out. For whilst the carriage had an engine, there was no petrol tank at the outset. Even when it came to the regular test runs through Mannheim at night the family proved indispensable. The pioneer required assistance pushing the car and starting the engine, and sometimes he needed even more help when it came to driving home, a procedure which would often turn into pushing home on the initial attempts.

As we travel in comfort from A to B in the cars of today, there is no trace of all the effort involved in those early days. Thanks to an ingenious inventor and his family of seven. It’s for families such as these that we build the R-Class.



For Karl, Bertha, Eugen, Richard, Klara, Thilde and Ellen

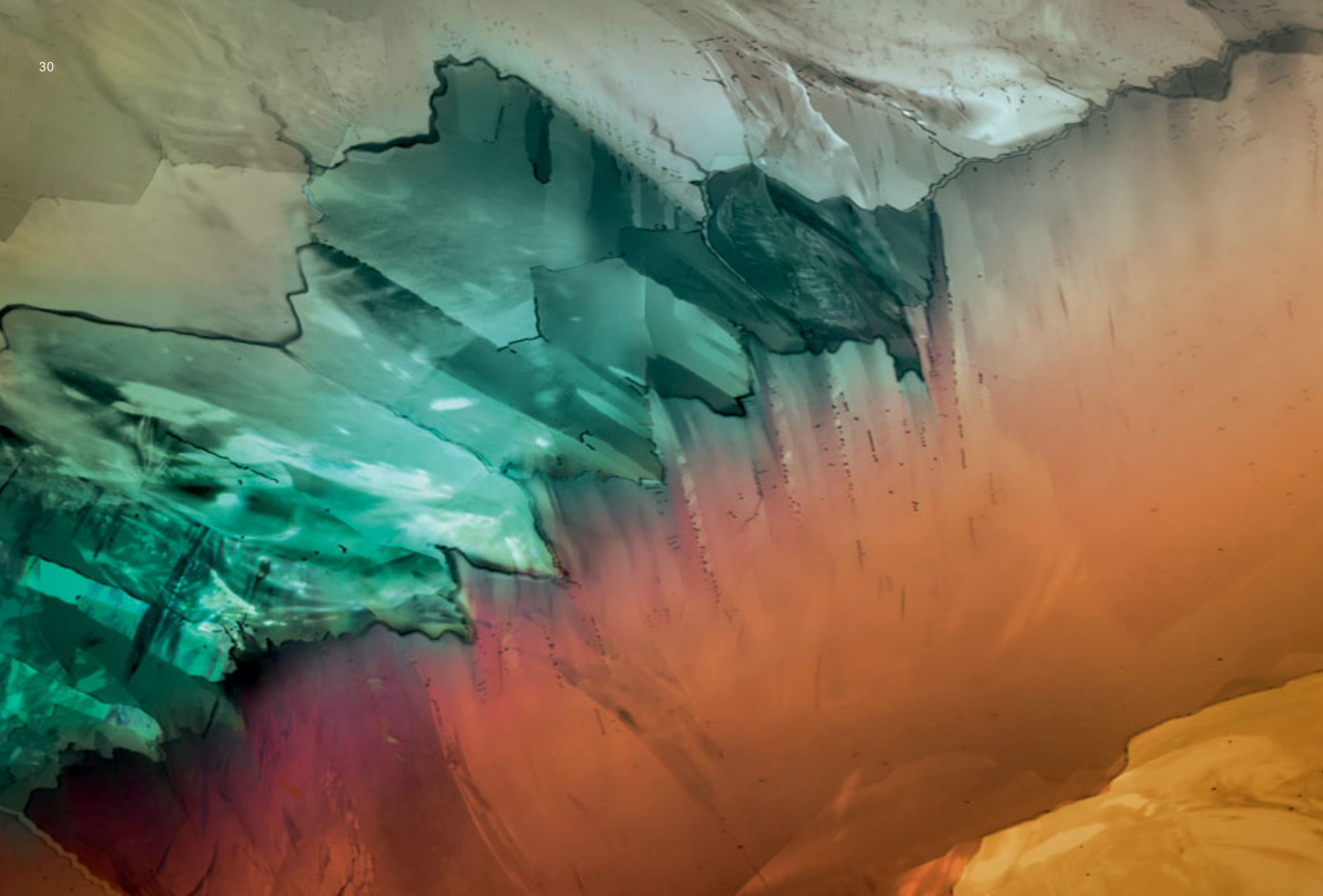

On the art of creating a clean diesel

Seen up close, BlueTEC is the most natural thing in the world. Because what looks like a shimmering precious stone here is in reality nothing more than crystallised urea under the microscope.

There's a very good reason why engineers at Mercedes-Benz – as well as naturopaths – scrutinise this wondrous organic compound. Urea is the main component of AdBlue® – the all-important fluid in the fight against diesel emissions. In our BlueTEC models, AdBlue® is injected into the prefiltered

exhaust gas flow. The urea binds the remaining nitrogen oxides through a natural chemical reaction and reduces them by up to ninety percent, leaving almost nothing but harmless nitrogen and water.

This all sounds pretty easy, one might think – not rocket science. But isn't that always the way with revolutionary ideas? It's just a matter of coming up with them. So if your Mercedes should pass water in future, it's because we have such clever engineers. There's nothing to worry about. It's only natural.

systems. Upholstery and trim. In an accident. Metallic paints. Sound system
as. Fuel consumption. Interior. In the event of danger. LED daytime running
Multimedia systems. Drive system. Genuine accessories. Airbags. Equipme
emissions. Upholstery and trim. Safety. Technical data. Comfort. Safe drivin
Acceleration. Design. Emission class. Safe driving. Light-alloy wheels. Top
s. Paintwork. Total displacement. Facts and colours. Climate control. Seats.
s. CO₂ emissions. Memory package. Transmission. Surround sound system.
Safety. Assistance systems. Upholstery and trim. In an accident. Metallic p
assis & suspension. Fuel consumption. Drive system. Interior. Airbags. In th
l displacement. **The facts.** Paintwork. Total displacement. Climate control. S
emory package. Transmission. Surround sound system. Wheels. Interior. Saf

36 **BlueEFFICIENCY**38 **Diesel engines**

6-cylinder

40 **Petrol engines**

6-cylinder

8-cylinder

42 **Transmissions**

7G-TRONIC

7G-TRONIC PLUS

DIRECT SELECT

44 **Chassis & suspension**

4MATIC

Direct-Steer system

AIRMATIC

46 **Safe driving**

Blind Spot Assist

DISTRONIC

Bi-xenon headlamps and LED
daytime running lamps

ESP®

48 **In the event of danger**

PRE-SAFE® system

49 **In an accident**

Airbags

NECK-PRO head restraints

50 **Seating variants**

5-seater

4+2-seater

5+2-seater

52 **Folding variants**

Flexibility

Child seat concept

Spaciousness

54 **Load compartment**

EASY-PACK system

Load compartment

Load compartment floor

56 **Multimedia systems**

COMAND APS

Rear Seat Entertainment System

57 **Assistance systems**

PARKTRONIC

Reversing camera

58 **Climate control**

THERMATIC

THERMOTRONIC

Rear climate control

59 **Seats**

Multicontour Seat package

Memory package

Rear centre console

The R-Class in detail

60 Long-wheelbase version

62 Standard equipment

63 Optional extras

64 Chrome package

66 Sports package

Exterior Sports package

Interior Sports package

68 AMG Interior Sports package

70 Upholstery and trim

76 Wheels

78 Genuine accessories

80 Services

MercedesCard

Mercedes-Benz Financial Services

Mercedes-Benz mobility

Mercedes-Benz Museum

Test drive

Interactive Owner's Manual

Mobile internet

Service packages

Repair following an accident

82 Dimensions

R-Class

R-Class: long-wheelbase
version

82 | 85 Paintwork

83 Technical data

BlueEFFICIENCY – fast forward to tomorrow

We are quicker at getting environmentally friendly future technologies to where it matters most: on the road. As the inventor of the motor car, Mercedes-Benz has a special responsibility – one we have undertaken with all our might for many years. By the end of 2012, you will have more than 140 Mercedes-Benz models with BlueEFFICIENCY technologies at your disposal, all of which help you reduce your impact on the environment – without compromising on safety, comfort and driving enjoyment.

Our BlueEFFICIENCY concept comprises innovations for efficient mobility as well as optimised processes all the way along the value chain. They involve different approaches, but they all have a common goal: to make your individual mobility as sustainable as possible.

The BlueEFFICIENCY measures – the Mercedes-Benz efficiency package. This package consists of comprehensive vehicle optimisations designed to save fuel and ease the burden on the

environment. Each model combines the most efficient engine with latest-generation aerodynamic and energy-management measures to minimise fuel consumption. Such measures include intelligently controlled ancillaries, tyres with optimised rolling resistance, lightweight components and the ECO start/stop function, which is being made available for an increasing number of models. The BlueDIRECT V6 and V8 petrol engines, which feature in several model series, deliver a much higher power output while reducing fuel consumption by up to 25%.

BlueTEC – the clean diesel. Mercedes-Benz has brought to market BlueTEC technology for diesel engines based on common-rail direct injection (CDI). A modular emission-control system makes BlueTEC an exceptionally clean diesel technology, as not only does it remove up to 95% of the particulate matter from the exhaust gases, it also reduces nitrogen oxides by up to 90%. What remains is mainly water, nitrogen and the satisfying feeling of having helped the environment.

HYBRID – petrol and electric drives intelligently combined. A well-established team makes a lot of things easier. And this is certainly true in the case of HYBRID technology. Here the electric motor is used for the recuperation of kinetic energy. This energy is stored in the battery and returned to the electric drive when needed, which assists the petrol engine when the car is accelerating. What's more, the ECU shuts off the petrol engine when the speed is below 15 km/h. In this way, a HYBRID implements significant fuel savings. So it looks after the environment as well as your bank balance. Perfect teamwork, you might say.



The BlueEFFICIENCY measures bring about a substantial reduction in fuel consumption and CO₂ emissions



BlueTEC HYBRID – clean diesel combined with electric drive. It marries the benefits of the HYBRID with those of BlueTEC: during braking, the kinetic energy is converted into electrical energy, which can be re-used when required. At the same time, the BlueTEC technology cleans exhaust gases and removes many of the pollutants. All of which makes the economical diesel powerplant even more efficient, agile and clean.



We are using **BlueTEC HYBRID technology** to develop a diesel hybrid based on the E-Class

Innovative drive systems that break new ground: E-CELL and F-CELL. Mercedes-Benz has developed two locally emission-free drive systems known as the E-CELL and F-CELL. The B-Class F-CELL¹ is already being produced on a small scale and has been on the roads since mid-2010 – during the F-CELL World Drive, for example, it proved its suitability for everyday use in varying conditions all over the globe. It uses hydrogen to produce power for the electric motor in a fuel cell. Since the beginning of 2011 a small series of the A-Class E-CELL¹ with an electric motor has been driving through Europe. It is powered by energy



The SLS AMG E-CELL¹ allows locally emission-free driving with a battery-powered electric motor

from two lithium-ion batteries and has an average range of more than 200 km. In all likelihood the SLS AMG E-CELL¹ super sports car, which achieves superb performance figures purely electrically, will also be entering series production from 2013. An E-CELL PLUS is also scheduled for release, which will include a small internal combustion engine combined with a generator to increase the range of the electric vehicle.

But that is not all: under the banner “Design for Environment”, we also look at a vehicle’s entire lifecycle and work hard to preserve the environment from the planning stage right through to recycling. The same applies to the building and running of new plants. In addition, we are heavily involved in the development of alternative fuels and carry out research in the field of bionics. In short, BlueEFFICIENCY is good news for both you and the environment.

Further information about our comprehensive measures can be found at:

www.mercedes-benz.com/blueefficiency

¹ Provisional data: efficiency class: A++

The data are not based on an individual model and do not constitute part of the product offer; they are provided solely for purposes of comparison between different vehicle models

Diesel engines

Powerful, quiet and clean with impressive fuel-consumption figures: the R-Class also signals the launch of the latest Mercedes-Benz diesel technology

V6 engines. The enhanced BlueTEC technology in the R 350 BlueTEC 4MATIC¹ with 155 kW is particularly low on emissions. BlueTEC is the name given to the technology developed by Mercedes-Benz for effective cleaning and after-treatment of exhaust gases from diesel drive systems. The modular system ensures exemplary values for all the exhaust-gas constituents as well as impressing by sustainably reducing nitrogen-oxide emissions. In practical terms, this means that BlueTEC already more than meets the emissions requirements of the future (Euro 6). Add to that lower consumption coupled with

effortlessly superior performance and a hefty torque of 540 Nm, and it's clear that the R 350 BlueTEC 4MATIC leads by example.

The R 350 CDI 4MATIC developing 195 kW features the most powerful V6 diesel engine with common-rail technology available for the R-Class. Precise and fast piezo injectors, a high injection pressure of up to 2000 bar and a huge maximum torque of 620 Nm – it all adds up to supreme pulling power. Not to mention very good traction performance thanks to the combination with the standard-specification all-wheel-

drive system 4MATIC, available in all versions. At the same time the engine runs smoothly, economically and cleanly, as you would expect from a state-of-the-art unit that complies with the Euro-5 emissions standard.

Efficiency is also the watchword where the R 300 CDI BlueEFFICIENCY² is concerned: with its systematic lightweight construction, the engine comes complete with common-rail diesel technology. It offers a respectable output (140 kW) and a high torque of 440 Nm, even at low revs, coupled with fuel-consumption and emission

¹ Only available as R-Class long-wheelbase version ² Not available as R-Class long-wheelbase version

levels which meet the requirements of the Euro-5 emissions standard. But that is not all: the measures integral to this model, such as tyres with low rolling resistance, intelligently controlled ancillaries and optimised aerodynamics, all help to boost the vehicle's efficiency.



The 6-cylinder diesel engine in the R 350 CDI 4MATIC has supreme pulling power on tap in every driving situation

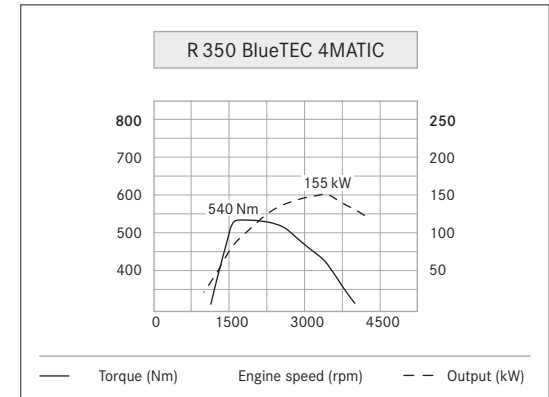

The R 350 BlueTEC 4MATIC achieves its maximum torque of 540 Nm as early as between 1600 and 2400 rpm

Petrol engines

There are two powerful and appropriately efficient petrol engines to choose from for the R-Class



Refined power is a trait of all the 6-cylinder petrol engines for the R-Class

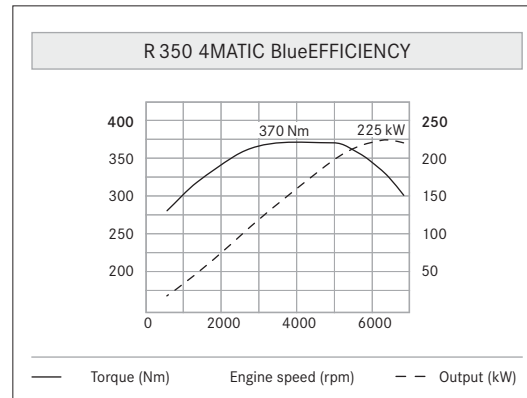

The R 350 4MATIC BlueEFFICIENCY with BlueDIRECT Technology package: exceptional pulling power across a wide engine speed range

V6 engine. The new 6-cylinder engine with four-valve technology and the BlueDIRECT Technology package in the R 350 4MATIC BlueEFFICIENCY embodies refined power and efficient fuel consumption. The maximum torque of 370 Nm facilitates immediate power delivery over a particularly wide engine speed range (3500–5250 rpm), which means that impressive reserves of power are available in every driving situation, ensuring relaxed motoring. A further defining characteristic of the V6 engine is its efficient use of fuel – one of the aims behind the further development of the third-generation direct petrol injection with

spray-guided combustion and piezo injectors. In conjunction with multi-spark ignition, it is therefore possible to save fuel effectively. The result: an output of 225 kW with fuel consumption that is 13% lower than that of the predecessor engine.

V8 engine. Simply outstanding. One way to describe the flagship powerplant in the R-Class range: the R 500 4MATIC¹. Effortless superiority and smooth running characteristics are the major strengths displayed by this powerful V8 engine. Responsible for the high performance

potential are the lightweight-construction materials such as magnesium, which are also used in the world of motorsport, and the optimised air supply plus four valves per cylinder. This is how the 8-cylinder powerplant develops its rated output of 285 kW and achieves a peak torque of 530 Nm, which is available over a wide engine speed range from 2800 to 4800 rpm. The R 500 4MATIC¹ accelerates from 0 to 100 km/h in 6.3 seconds and reaches a governed top speed of 250 km/h. This petrol engine also meets the requirements of the current Euro-5 emissions standard.

¹ Only available as R-Class long-wheelbase version

Transmissions

The intelligent 7G-TRONIC and 7G-TRONIC PLUS automatic transmissions constantly adapt to meet the requirements of the current driving situation and the individual driving style of whoever is at the wheel

7G-TRONIC. The R-Class comes as standard with the 7G-TRONIC automatic transmission, operated via the DIRECT SELECT lever on the steering column. The seven forward gears allow an ideally adapted engine speed at all times, cutting fuel consumption, which is further reduced by the 7G-TRONIC PLUS in the R 300 CDI BlueEFFICIENCY¹, R 350 CDI 4MATIC and R 350 4MATIC BlueEFFICIENCY. Shorter shift times and smoother shifts make gear changes easier and reduce noise levels. Driving enjoyment is also enhanced: the car benefits from better acceleration and boasts more pulling power. What's more, gears can be skipped for fast in-gear acceleration.

¹ Not available as R-Class long-wheelbase version

DIRECT SELECT. The R-Class features the intuitively operated DIRECT SELECT lever on the steering column instead of the conventional automatic selector lever in the centre console. You can select the automatic transmission modes P, N, R and D by moving the lever up or down and at the push of a button. The function commands are transmitted purely electronically. Manual shifting is also possible – via the standard-specification shift paddles on the steering wheel. This means that drivers can decide for themselves whether to control gear changes manually via the steering-wheel gearshift paddles or to leave it up to the automatic transmission. The freedom to make decisions is

just one of many comfort features the R-Class has to offer.



DIRECT SELECT lever

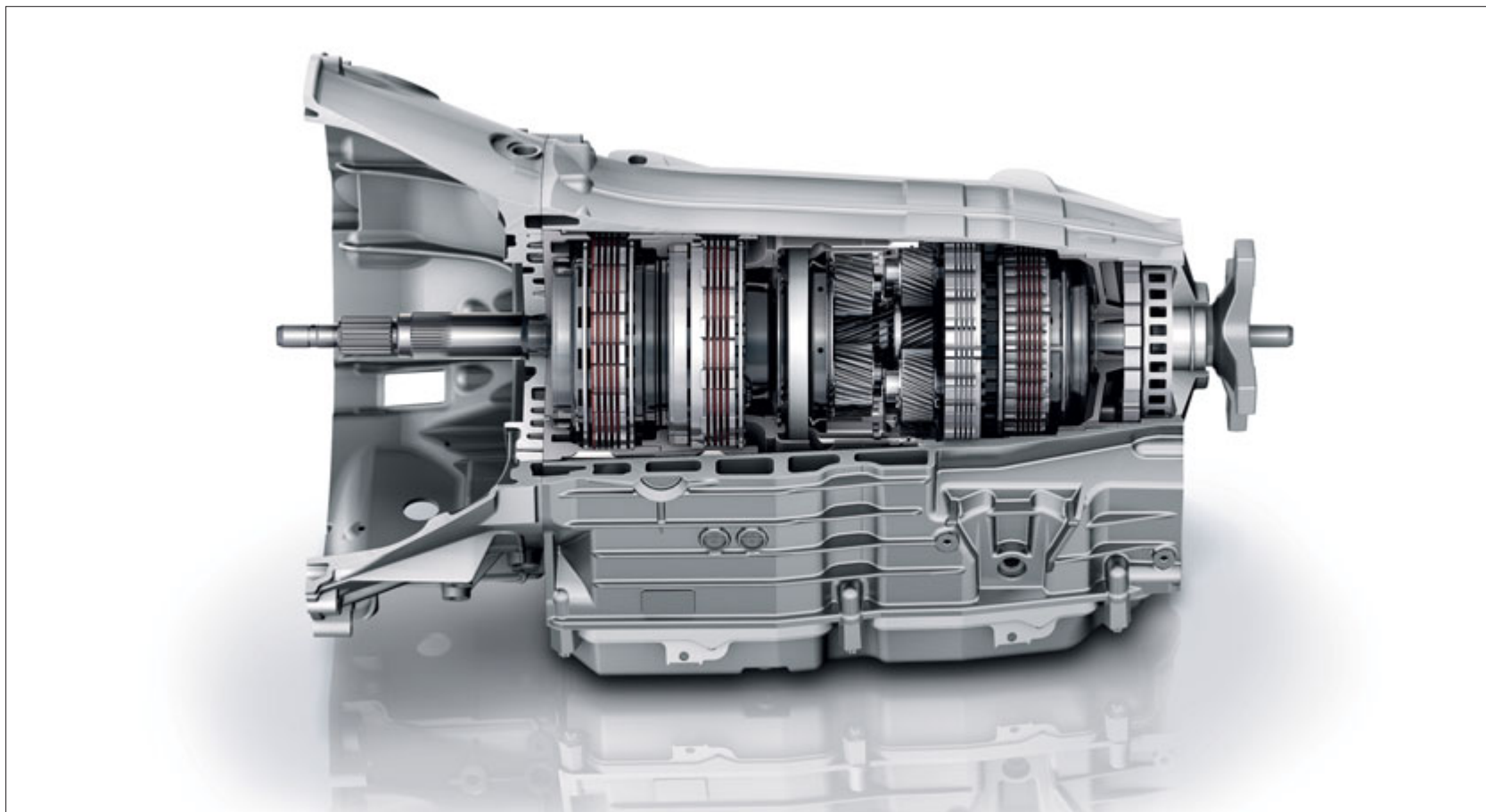

The 7G-TRONIC PLUS: one of over 18 million Mercedes-Benz automatic transmissions produced in a period spanning more than 50 years

Chassis and suspension

4MATIC permanent all-wheel drive provides impressive traction as well as enhanced driving stability. The chassis and the AIRMATIC air suspension really come into their own on the road, offering a high level of comfort as well as exceptional agility

4MATIC (depending on model). As 4MATIC is always active, it responds virtually instantaneously in poor weather conditions such as rain, black ice or snow. 4MATIC is assisted by the Electronic Stability Program ESP® and the electronic traction system 4ETS with the integral ABS and ASR functions. 4ETS enables controlled braking of spinning wheels and, as a consequence, increases the drive torque at the wheels offering good

traction, allowing plenty of power to be planted on the road when moving off and when accelerating, especially on poor road surfaces. 4MATIC makes conventional differential locks superfluous: the automatic braking pulses make it easier to move off on slippery ground as well as enhancing stability during critical manoeuvres. A further advantage of the system is the fact that it is hardly any heavier than the rear-wheel-drive

version on account of the compact design, intelligent choice of materials and high level of efficiency.

Direct-Steer system (standard). The Direct-Steer system features a steering ratio that becomes increasingly direct the greater the steering angle, and it reduces the steering effort required for large steering angles, for example when parking

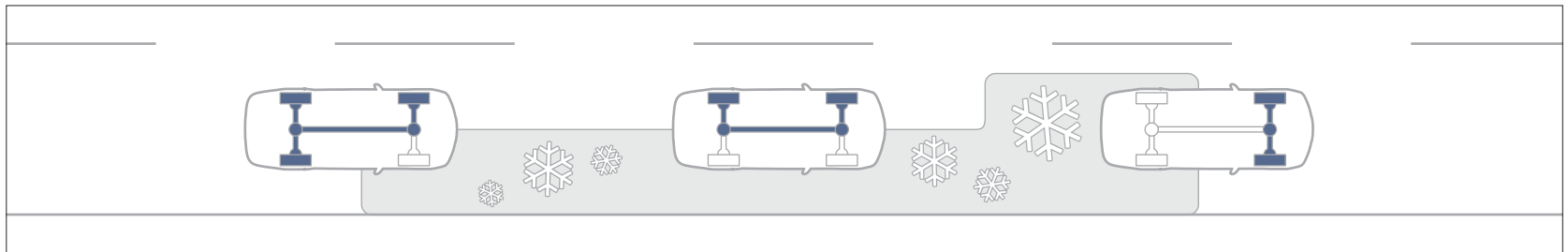

The electronic traction system 4ETS automatically sends the drive torque to the wheels offering sufficient traction

or negotiating tight bends. This increases the vehicle's agility and steering comfort through precise steering characteristics and good feedback. The electrohydraulic power steering in the R 300 CDI BlueEFFICIENCY¹ and R 350 BlueTEC 4MATIC² also helps to save fuel.

AIRMATIC (option). AIRMATIC air suspension, with adaptive shock absorbers, adjusts itself in line with the current road conditions, vehicle load and driving situation. The driver can select either comfort-oriented or sporty settings manually. Or the system will switch to stiffer settings of its own accord, while the level of the car can also be altered as required at the touch of a button.

¹ Not available as R-Class long-wheelbase version

² Only available as R-Class long-wheelbase version

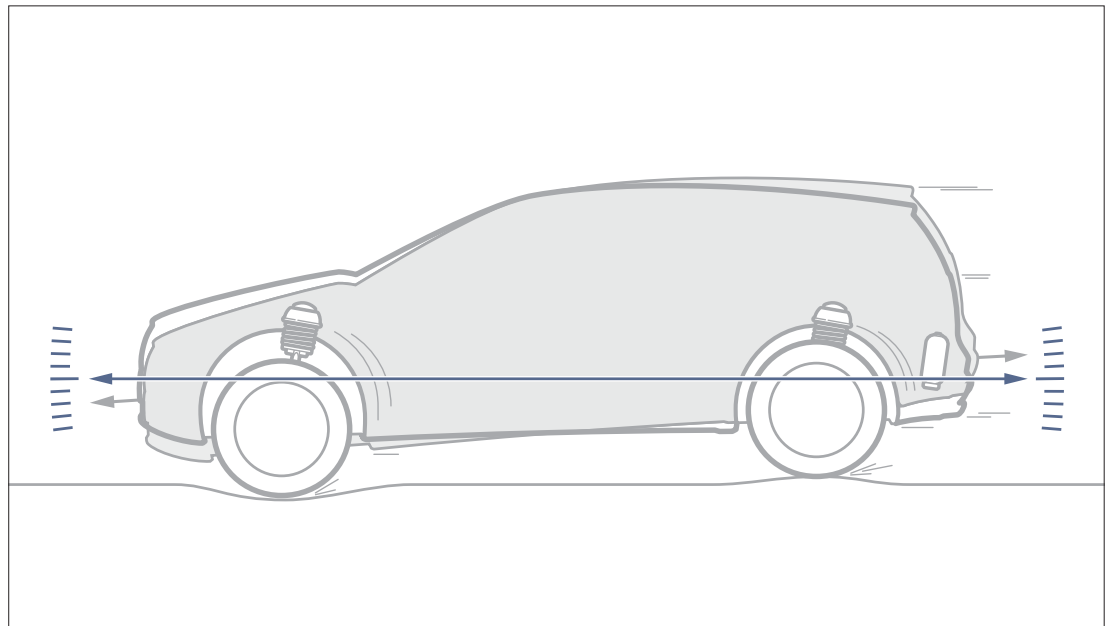

The AIRMATIC air suspension enhances ride comfort, especially when road conditions are poor

Safe driving

Mercedes-Benz pursues a comprehensive safety philosophy: the integral safety concept. At its core lies the vision of accident-free driving. Numerous measures support the driver in critical situations and can help to prevent an accident

Blind Spot Assist (option). The Blind Spot Assist system monitors the area which the driver finds difficult to see directly beside and behind the vehicle – in short: if the assistance system detects the danger of an impending collision with another vehicle when changing lane, the driver is warned by a signal in the exterior mirror from a speed of 30 km/h. If the driver

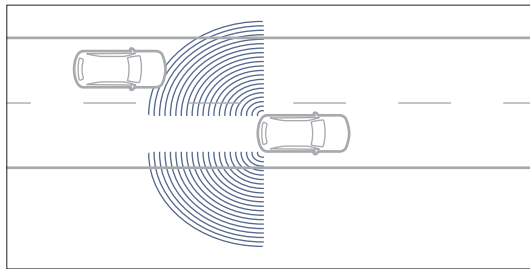

Blind Spot Assist uses two radar sensors to monitor the blind spot

uses the indicator in a situation like this, an additional audible warning sounds. This also occurs if the system detects that another vehicle is moving from the next-but-one to the next lane.

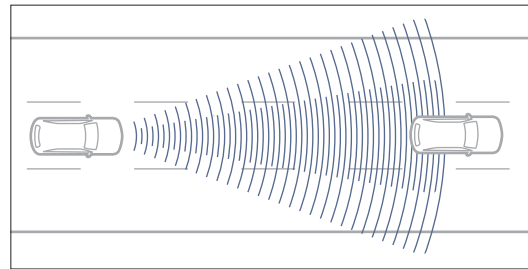

DISTRONIC can make the driver's job easier and improve driver-fitness safety

DISTRONIC (option). The DISTRONIC adaptive cruise control uses a radar sensor to help the driver maintain the set distance to the vehicle in front in a speed range of 0 to 200 km/h. This takes a lot of strain off the driver, particularly on motorways, on roads with motorway-like conditions and in heavy traffic: if the system recognises that your R-Class is approaching a slower vehicle ahead, it decelerates or activates the brake of its own accord. When the road is clear again, DISTRONIC continues to work like conventional cruise control.

Bi-xenon headlamps with LED daytime running lamps (option). Excellent visibility and light conditions are ensured thanks to the combination of bi-xenon headlamps and LED daytime running lamps. The latter comprise two lamps, each with seven light-emitting diodes, to make them more easily visible to other road users. They are also available on their own as optional extras.

Further advantages include low electrical consumption and a long life. And last but not least, the distinctive design and sophisticated light pattern enhance looks. The bi-xenon headlamps offer better light intensity, a greater beam range and wider illumination than conventional headlamps. The electric headlamp range control prevents drivers in oncoming traffic from being

dazzled, whilst the headlamp cleaning system keeps the headlamps free of dirt.

ESP® incl. trailer stabilisation (standard). While towing, trailer stabilisation gives the driver further support in addition to that provided by the standard-fit Electronic Stability Program ESP®. If the vehicle/trailer combination starts swinging back and forth when on the move, this intelligent system can recognise the problematic driving situation and apply short brake actuations to stop this movement promptly.



Thanks to the LED daytime running lamps other road users can see the vehicle more easily

In the event of danger

Anybody who travels on the road will have to face a dangerous situation sooner or later. That's why a range of systems has been developed for the R-Class to help mitigate the severity and consequences of possible accidents

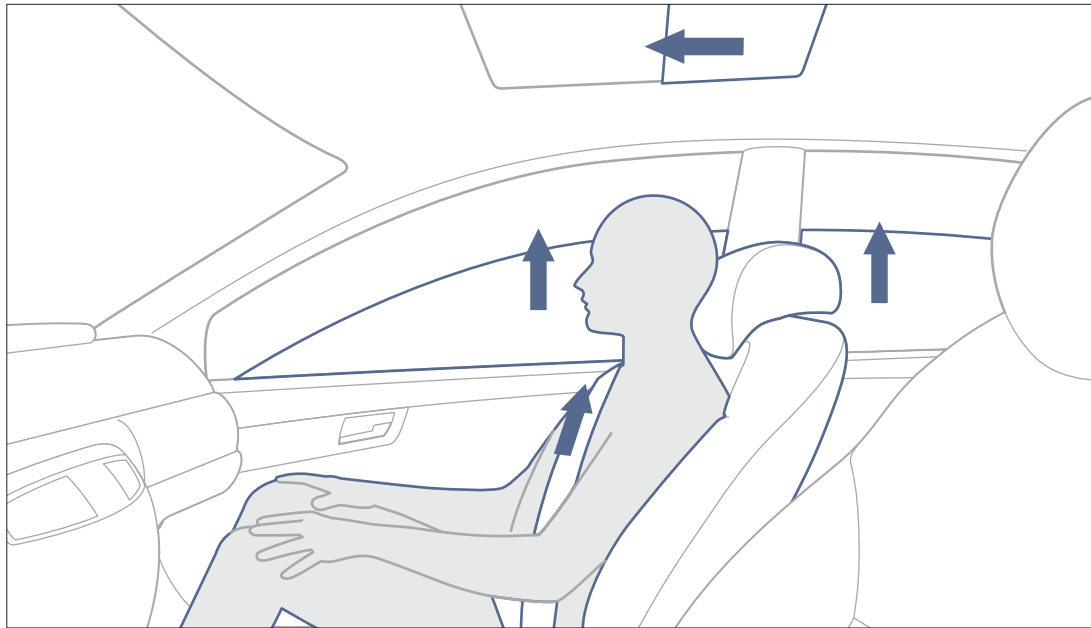

PRE-SAFE® system (standard). The anticipatory occupant protection system is able to detect certain critical driving situations in advance and activate preventive measures. If an imminent accident is detected, the system can close the side windows, move the front passenger seat to a more favourable position and tension the front seat belts by means of electric motor. It can also close the sliding sunroof, if fitted, and provide lateral support for the occupants if the multicon-tour seats are specified.

The anticipatory occupant protection system PRE-SAFE® can recognise critical driving situations and initiate preventive measures in order to protect the occupants

In an accident

The R-Class provides a safer environment, even in the event of a possible collision. Multiple protective measures are activated to help protect the occupants and significantly mitigate the consequences of accidents

Airbags (standard). Fitted as standard inside the R-Class are six airbags which can help prevent – or reduce the severity of – injuries in case of a collision. Passenger protection measures include two adaptive front airbags which can deploy in two stages, depending on the projected impact

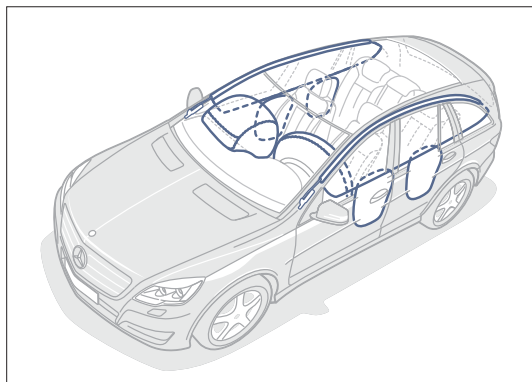

Standard equipment includes windowbags for all three possible seat rows plus airbags & sidebags for the driver & front passenger

severity. The R-Class also has sidebags in the front seat backrests for the driver and front passenger, plus two large windowbags extending over each of the three seat rows that are possible. Sidebags for the second row of seats are also available as an option.

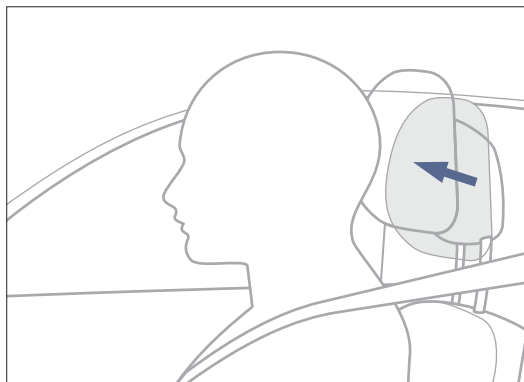

The flexible side bolsters on the NECK-PRO luxury head restraints can be adjusted by hand for the driver and front passenger

NECK-PRO head restraints (standard). The crash-responsive NECK-PRO head restraints improve occupant protection and help to reduce the risk of whiplash injury. If a rear impact is detected, the head restraints are pushed forwards by around 40 millimetres and upwards by 30 millimetres, thus providing support for the heads of the front seat occupants at an earlier stage. The flexible side bolsters on the optional NECK-PRO luxury head restraints provide additional lateral support for the head, whilst also enhancing seating comfort.

Seating variants

Ready for any challenge: the variable interior concept with up to seven seats



Comfort from front to back: Executive Chairs in the generously sized rear

5-seater (standard). You always travel first-class in the R-Class – even in the second row. The luxurious individual-seat concept enhances ride comfort for all the passengers. With its two Executive Chairs, the rear is as inviting as the front when it comes to the levels of space and comfort on offer. There is also a comfortable centre seat, which can simply be folded down if you wish, in which case it serves as a practical, comfortable centre armrest.

4+2-seater (option). This configuration includes a rear centre console for the second seat row, featuring two cup holders and numerous stowage facilities. So the already generous amount of space for the rear passengers can be increased even further. The third row offers two more seats, both of which can be folded away as required.

5+2-seater (option). As in the 4+2-seater, you reach the individual seats in the third row in comfort courtesy of the EASY-ENTRY system, which is automatically integrated in both variants.

Even with seven people on board there is still room for some light luggage. In addition to this the 5+2-seater is equipped with air suspension and level control on the rear axle as standard.



Six pack: the 4+2-seater with six comfortable individual seats



Particularly generous – particularly flexible: the 5+2-seater with its folding centre seat

Folding variants

Manifold possibilities – the variable interior concept of the R-Class in detail



You can transform the interior into a flat load area in just a few simple steps

Flexibility. To enable you to derive maximum benefit from the generous R-Class interior, we have developed an intelligent individual-seat concept. Its main advantage is that each rear seat can be folded forward separately. As well as the standard five-seat configuration, you also have the option of two, three, four, six or seven seats.

Child seat concept. The R-Class effortlessly achieves top marks as a family car, too. In the second row of seats there is room for up to three child seats next to each other. The two outer seats have ISOFIX attachment systems which make it possible to anchor the child seat directly to the car's body. Because safety is a big priority for us when it comes to your smallest passengers.

Spaciousness. If there are five of you in the car, there's still room in the boot for six large suitcases – more than sufficient for five people. A few steps are all it takes to make full use of all the space the R-Class has to offer: simply fold forward the seat cushions and backrests in the second and third rows. This won't create any steps or recesses – just the type of load area you'd

expect to find in a delivery van rather than a luxury saloon.



The innovative individual-seat concept in the R-Class



One by one: each seat can be folded forward individually

Load compartment

Luxury means not having to do without anything – especially luggage



In the end only comfort counts: the EASY-PACK system helps you when loading up

EASY-PACK system (option). The R-Class makes light work of heavy luggage: the EASY-PACK load compartment management system makes loading and stowing as easy as can be. The EASY-PACK tailgate available as an option opens and closes at the touch of a button, and can be stopped in any position – very handy for avoiding contact with low garage ceilings, for instance.

Load compartment. Open up the tailgate and you will find that a luxurious amount of space with a total of up to 2001 litres of load capacity (or 1950 litres in the 4+2- and 5+2-seater) comes as standard. A load compartment length of nearly two metres means that you have enough space for almost anything – whether you want to take the bicycles on holiday with you or find yourself having to transport a bulky sofa. A high-quality velour covering means that your

luggage can also travel in style. The optional load compartment cover helps keep things looking neat and tidy and also protects your possessions from prying eyes.

Load compartment floor. The 5-seater R-Class comes with a large load compartment flap recessed into the load compartment floor as



Safety and comfort rolled into one: optional partition net for occupant protection and load retaining

standard, adding a 51-litre stowage compartment to the already generous luggage space (not included in the 4+2- or 5+2-seater).



Room for more: there is a generous stowage area beneath the load compartment

Multimedia systems

As an option the R-Class offers an entire programme of entertainment, including such features as the Rear Seat Entertainment System or the COMAND APS multimedia system. Meanwhile, the Harman Kardon® Logic 7® surround sound system, also available optionally, sets the tone perfectly

COMAND APS (option). The COMAND APS multimedia system combines a radio and MP3 player with a hard-disc navigation system including high-resolution map display and TMC PRO dynamic route guidance. Three years of free updates for your map data are included (vehicle-specific, from date of first registration). The system shows all the information you need



The COMAND APS is extremely easy to use

on a 16.5 cm central colour display. The DVD drive brings you the best in entertainment, and as well as video and audio DVDs it also plays CDs and MP3 files. What's more, there is a further 4 GB of memory on the hard disc for audio files in MP3 or WMA format. And an SD memory card slot and Aux-in connection are included in the standard specification. All the major functions can



The two displays for the Rear Seat Entertainment System are mounted on the front-seat head restraints

also be called up via the voice-operated control system LINGUATRONIC.

Rear Seat Entertainment System (option). The Rear Seat Entertainment System comprises a DVD player, two 20.3 cm TFT colour displays on the front head restraints, two sets of wireless headphones, remote control and two Aux-in sockets, allowing the rear passengers to watch films or connect a games console during the journey. Both displays can be used independently of one another. Thanks to the optionally available TV receiver passengers in the R-Class can even watch currently broadcasting television programmes.

Assistance systems

Assistance systems provide additional convenience in the R-Class. Parking is now child's play, thanks to PARKTRONIC and the reversing camera

PARKTRONIC (option). The PARKTRONIC parking aid helps the driver when parking and manoeuvring in tight spaces. If PARKTRONIC detects that there is not enough space available in front of or behind the vehicle, it can warn the driver by giving visual signals. These are accompanied by audible signals if the distance is below 35 cm. The system works according to the echo-sounder principle; a total of ten sensors send out ultrasound signals which are reflected by other vehicles or obstacles.

Reversing camera (option). Available as an option, the reversing camera can likewise make parking easier. Its wide-angle lens is integrated in the handle on the tailgate. The reversing camera is automatically switched on when reverse gear is engaged, and shows on the COMAND display

exactly what it detects in the area immediately behind the vehicle, so it helps make reverse parking easier and safer by giving the driver a better view of the area surrounding the car's

tail end. The reversing camera is available exclusively in conjunction with COMAND APS.



The reversing camera films the area around the tail end of the car

Climate control

An ideal interior climate is paramount when it comes to ensuring a high level of stress-relieving safety. The climate control system for the R-Class is therefore exceptionally versatile and can be adjusted to meet the needs of each individual occupant

THERMATIC (standard). The THERMATIC automatic climate control system uses sensors to control the air distribution, temperature and ventilation automatically and separately for the left- and right-hand side of the interior (2 climate zones). In accordance with the preselected temperature and the desired air distribution, the air is cooled or heated automatically, making the system very easy to operate. This automatic control process can be manually overridden if required. Further standard-fit features include air recirculation and the combination filter (dust and activated charcoal filter), which keeps particulate matter at bay and improves the overall air quality.

THERMOTRONIC (option). The THERMOTRONIC luxury automatic climate control system allows the driver, front passenger and rear passengers each to set the temperature using their own controls. An additional booster blower beneath the centre console ensures the ideal temperature in the rear. What's more, further sensor signals are included in the control system in order to create a pleasant interior climate.



The controls for the THERMOTRONIC luxury automatic climate control system are ergonomic and intuitive

Rear climate control (option). In conjunction with THERMOTRONIC, the separate air conditioning system in the rear enhances climate comfort for the rear passengers. This is a welcome addition, especially if the vehicle is equipped with three rows of seats.



The desired temperatures and airflow can be set precisely using the control panel in the rear

Seats

The exclusively designed seats in the R-Class meet the highest standards and provide impressive levels of comfort on long journeys

Multicontour Seat package (option). The multicontour seats offer a high level of comfort on long-distance journeys. The seat height and seat-cushion and backrest angles are all electrically adjustable. Individual air chambers are pressurised in line with the current driving situation to provide more stability and lateral support in the lumbar area, in the backrest side bolsters and in the front section of the seat cushion.



The multicontour seats for the driver and front passenger meet all your individual ergonomic seating needs

Memory package (option). The front seats are available with full electrical adjustment as an optional extra (including 4-way lumbar support for the front passenger seat). The switches for this are clearly arranged in the seat console. If the Memory package is ordered, three position settings can be stored for the driver's seat, steering column and exterior mirrors.



Memorised settings can be restored quickly and accurately at the mere touch of a button

Rear centre console (standard for 4+2-seater). The 4+2-seater features a removable rear centre console with two cup holders and numerous stowage facilities. When closed the lid serves as an armrest housing a compartment with seven litres of stowage space.



The rear of the 4+2-seater R-Class with the rear centre console in the second seat row

Long-wheelbase version

An extra measure of greatness. 235 millimetres, to be precise



Vehicle of unlimited possibilities: the long-wheelbase version stretches over 5.16 metres

It's hard to beat the R-Class when it comes to spaciousness and comfort. Unless, that is, you decide to go for the long-wheelbase version of the R-Class. As the driver you'll barely notice the difference of 235 mm – but your passengers certainly will. If six or seven people are on board, those in the third row in particular will be more comfortable. And it goes without saying that the boot capacity also increases proportionately – by 414 l.

When only the first and second seat rows are in use, the load capacity is 1118 l for the 5-seater (1067 l in the 4+2-seater and 5+2-seater). In the 4+2-seater and 5+2-seater the seats in the second row can be moved to create a distance of up to 990 mm to the front seat row – a degree of spaciousness and comfort comparable to that found in luxury saloons. The telling difference

in the R-Class? In 2-seater configuration, the long-wheelbase version can offer a maximum load capacity of up to 2436 l (2385 l in the 4+2- and 5+2-seaters), whilst the maximum loading

length grows to 2.19 m. So now there's no stopping you whenever you feel like a spur-of-the-moment trip to the coast with your surfboard.



More legroom and headroom in the rear

Standard equipment | Selection



Instrument cluster in 3D look, with white scale



Stowage compartment in the front armrest



Front door sill panels in stainless steel



Stowage space beneath load compartment floor (for 5-seater)



Daytime running lamps and front fog lamps ringed in chrome



Tail light featuring LED and fibre-optic cable technology

Optional extras | Selection



Media Interface socket in glove compartment



NECK-PRO luxury head restraints (for first and second seat row)



EASY-PACK tailgate



EASY-ENTRY function (for 4+2- and 5+2-seater)



Roller sunblind, rear side window (for second seat row)



Panoramic sliding sunroof

Chrome package

Polishes your look – the Chrome package available as standard

The Chrome package further enhances and distinguishes your R-Class: the window frames and the beltline trim strips are appliquéd in high-gloss aluminium. The door handles and rub strips are painted in the vehicle colour

and feature chrome highlights (chrome highlights for door handles in conjunction with KEYLESS-GO). The simulated underguard at the front end sports a chrome look. All of this, fitted as standard at the factory, makes the

R-Class a seriously sporty and attractive proposition. Allowing the driver to shine just as the car does.



Dynamic: the simulated underguard with its chrome look



Elegant: door handles in vehicle colour with chrome highlights



Small details make a big impression: an array of chrome highlights accentuates the striking lines of the R-Class

Sports package

The Exterior Sports package emphasises the muscular lines of the R-Class; the Interior Sports package adds an athletic touch to the passenger compartment



The masculine front and the wide radiator grille take the road by storm. And the rest is pretty powerful and distinctive, too: the Exterior Sports package

Exterior Sports package. The defining features of the R-Class with the Exterior Sports package are the 5-twin-spoke light-alloy wheels with 265/45 R 20 tyres all round and rear air suspension, plus the blue tinted windows.

Interior Sports package. Opt for elegant sportiness in the passenger compartment, too. The package comprises electrically adjustable front sports seats with an Alcantara®/ARTICO man-made leather upholstery combination featuring contrasting topstitching, a sports steering wheel and the Interior Light package.

Aluminium trim and sports pedals in brushed stainless steel with rubber studs also add to the dynamic character.



The sports seats in Alcantara®/ARTICO man-made leather



Palpably more dynamic: Interior Sports package

AMG Interior Sports package

We proudly present: possibly the world's most elegant fitness room



Dynamism at your fingertips: AMG sports steering wheel with steering-wheel gearshift paddles

AMG Interior Sports package. Exclusive sportiness for the R-Class is yours to enjoy courtesy of the Interior Sports package from Mercedes-AMG. A feeling of dynamism is imparted, for instance, by the electrically adjustable AMG sports seats with a multicontour function for the driver and front passenger, and also by the AMG sports steering wheel with steering-wheel gearshift paddles for changing gear manually. The seats, armrests and handles in the doors as well as the armrest between the front seats are covered in nappa leather. The athletic look is enhanced by trim in aluminium and sports pedals in brushed stainless steel with rubber studs. Additional exclusive features include the Interior Light package and AMG floor mats.



AMG sports seats in nappa leather with a multicontour function

Upholstery and trim





The black colour scheme offers a choice between seat covers in ARTICO man-made leather (standard) and leather seat upholstery (optional). Meanwhile, the interior (dashboard, centre console, door centre panels and carpet) is all in black. If the Interior Sports package is selected as an option, the seat upholstery is in a combination of Alcantara®/ARTICO man-made leather with topstitching in a contrasting colour. In conjunction with the optional AMG Interior Sports package, the seats as well as the door centre panels, handles and armrests are trimmed in black AMG nappa leather.

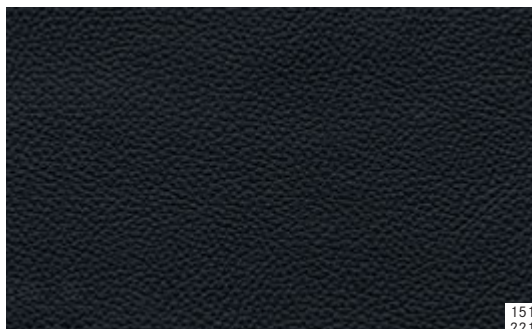

151
221

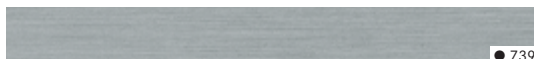

● 739



● 734



● 731



● 729

BLACK

- 151 ARTICO man-made leather
- 221 Leather²

TRIM

- 739 Dark longitudinal-grain aluminium
- 734 High-gloss brown eucalyptus wood¹
- 731 High-gloss brown burr walnut wood with chrome panels²
- 729 High-gloss anthracite poplar wood with chrome panels²

¹Optional extra, standard for V8 ²Optional extra
 ● Recommended ○ Possible △ Not recommended

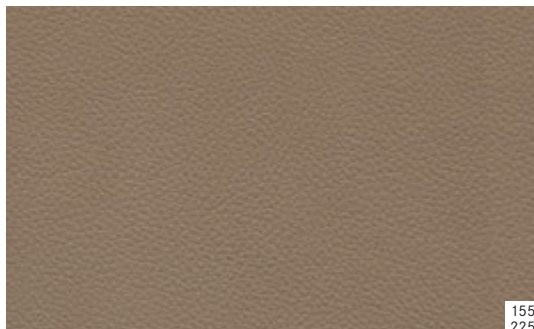

The almond beige colour scheme offers upholstery in ARTICO man-made leather (standard) or leather (option). In addition to the seats, the dashboard, centre console, carpet, door centre panels and door edges are also in almond beige. The upper section of the dashboard, the multifunction steering wheel and the armrests in the doors provide a dark contrast.

155
225

△ 739



● 734



● 731



○ 729

ALMOND BEIGE

- 155 ARTICO man-made leather
- 225 Leather²

TRIM

- 739 Dark longitudinal-grain aluminium
- 734 High-gloss brown eucalyptus wood¹
- 731 High-gloss brown burr walnut wood with chrome panels²
- 729 High-gloss anthracite poplar wood with chrome panels²

¹Optional extra, standard for V8 ²Optional extra

● Recommended ○ Possible △ Not recommended



The optional black/almond beige colour scheme offers seat upholstery, door edges and the centre section of the dashboard in almond beige. The multifunction steering wheel, centre console, dashboard upper and lower sections, armrests in the doors and between the front seats plus the carpet are in contrasting black. The black/almond beige colour scheme is available in ARTICO man-made leather as standard or leather as an option.

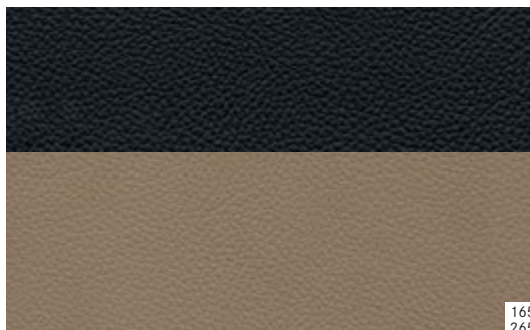

165
265

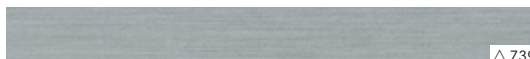

△ 739



● 734



○ 731



● 729

BLACK/ALMOND BEIGE

- 165 ARTICO man-made leather
265 Leather²

TRIM

- 739 Dark longitudinal-grain aluminium
734 High-gloss brown eucalyptus wood¹
731 High-gloss brown burr walnut wood with chrome panels²
729 High-gloss anthracite poplar wood with chrome panels²

¹Optional extra, standard for V8 ²Optional extra
● Recommended ○ Possible △ Not recommended

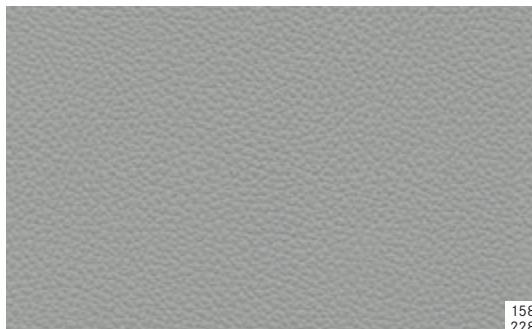
158
228

● 739



△ 734



△ 731



● 729

The alpaca grey colour scheme offers upholstery in ARTICO man-made leather (standard) or leather (option). The seats plus the dashboard, centre console, door centre panels and door edges are all in alpaca grey. The upper section of the dashboard, the multifunction steering wheel, the armrests in the doors and the carpet add dark contrasts. In conjunction with the Interior Sports package available as an optional extra, the seat upholstery comes in a combination of Alcantara®/ARTICO man-made leather featuring topstitching in a contrasting colour.

ALPACA GREY

- 158 ARTICO man-made leather
 - 228 Leather²
-

TRIM

- 739 Dark longitudinal-grain aluminium
 - 734 High-gloss brown eucalyptus wood¹
 - 731 High-gloss brown burr walnut wood with chrome panels²
 - 729 High-gloss anthracite poplar wood with chrome panels²
-

Optional extra, standard for V8 ² Optional extra

● Recommended ○ Possible △ Not recommended



With the optional black/alpaca grey colour scheme, the seat upholstery, door edges and the centre section of the dashboard are all in alpaca grey. The multifunction steering wheel, the upper and lower sections of the dashboard, the door centre panels, the armrests in the doors and between the front seats plus the carpet are in contrasting black. The black/alpaca grey colour scheme is available in ARTICO man-made leather as standard or leather as an option.

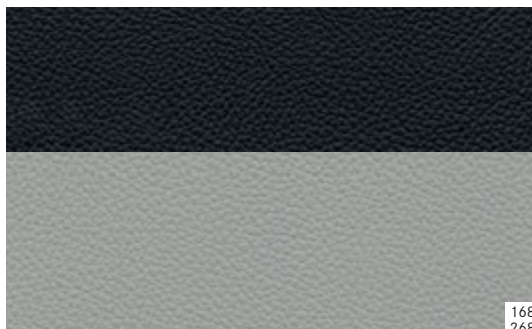

168
268

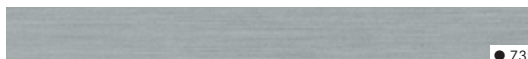

● 739



△ 734



△ 731



● 729

BLACK/ALPACA GREY

168 ARTICO man-made leather

268 Leather²

TRIM

739 Dark longitudinal-grain aluminium

734 High-gloss brown eucalyptus wood¹

731 High-gloss brown burr walnut wood with chrome panels²

729 High-gloss anthracite poplar wood with chrome panels²

¹Optional extra, standard for V8 ²Optional extra

● Recommended ○ Possible △ Not recommended

Wheels



10-spoke light-alloy wheels with 235/65 R 17 tyres (standard for R 300 CDI BlueEFFICIENCY, R 350 BlueTEC 4MATIC, Code 25R)



10-spoke light-alloy wheels with 255/50 R 19 tyres (optional, standard for R 500 4MATIC, Code R26)



10-spoke light-alloy wheels with 255/55 R 18 tyres (standard for R 350 CDI 4MATIC, R 350 4MATIC, no-cost option for R 300 CDI BlueEFFICIENCY, R 350 BlueTEC 4MATIC, Code R41)



5-spoke light-alloy wheels with 255/50 R 19 tyres (optional, Code R39)



5-twin-spoke light-alloy wheels with 265/45 R 20 tyres
(Exterior Sports package, Code R33)



5-spoke AMG light-alloy wheels with 265/40 R 20 tyres
(optional, Code 758)



5-spoke incenio "Sadalmelik" light-alloy wheels¹ for
255/50 R 19 tyres (genuine accessories)



5-twin-spoke light-alloy wheels with 265/45 R 20 tyres
(optional, Code 41R)



5-spoke AMG light-alloy wheels with 265/40 R 21 tyres
(optional, Code 777)



5-twin-spoke incenio "Alanz" light-alloy wheels¹ for
265/45 R 20 tyres (genuine accessories)

¹ incenio light-alloy wheels are supplied without tyres

Genuine accessories

Practical, versatile, generous – there's not much the R-Class can't do. And there are always the genuine accessories from Mercedes-Benz



The elegant, versatile roof box is available in two sizes: 450 or 330 litres

The New Alustyle basic carrier bars form the versatile basis for all Mercedes-Benz transportation and leisure solutions. They can be combined with a wide range of different roof attachments, such as roof boxes, ski and snowboard racks or bicycle racks. Made of aluminium, the aerodynamic basic carrier bars are very light, perfectly tailored to the body of the R-Class and easy to mount. You might like to pair them up with an elegant, high-quality roof box, which has a capacity of around 450 or 330 litres. The ideal transportation solution for all seasons, whether you want to take skis, snowboards, diving equipment, camping gear or luggage with you. The Mercedes-Benz roof box can be opened on both sides and is available in a range of colours and sizes.

The roof spoiler serves as an elegant visual extension of the roof line, making your R-Class appear even more compact and powerful from behind, yet without restricting the driver's field of vision. The roof spoiler can be painted in every colour shade available for the R-Class and is easy to fit.



Roof spoiler

The high-gloss chromed door handle recesses add a gleaming touch to your R-Class's chrome finish. They are of high practical value, guarding the paint in the handle recesses against scratches. The custom-fit inserts are available either just for the front doors or as a set of four.



High-gloss chromed door handle recesses

The KidFix¹ child seat is the ideal place for children aged from about 3½ to 12 (15 to 36 kg) to enjoy the ride and offers a high level of protection. The seat booster and the height-adjustable backrest ensure outstanding side impact protection. In addition to the 3-point seat belt, the KidFix¹ can be directly mounted to the car's body using ISOFIT child seat attachment points in the second seat row.

KidFix¹ child seat with transponders for automatic child seat recognition and ISOFIT attachment system

¹ Optionally available with "DaimlerSquare" cover

Services

MercedesCard. The card is your ticket to the Mercedes-Benz experience. Four times a year, we will send you the Mercedes-Benz Magazine, featuring fascinating reports from the world of Mercedes-Benz and articles about our latest vehicles. A MercedesCard also has many other uses too. As a VISA credit card, it is an internationally accepted means of payment. Further benefits are available to provide you with peace of mind, such as insurance packages for your Mercedes and other insurance services for the whole family. Further details can be found at www.mercedes-benz.com¹

Mercedes-Benz Financial Services. Mercedes-Benz stands for quality, innovation and safety – and the same applies to Mercedes-Benz Financial Services. Our innovative leasing and financing products are tailored to your financial needs and means, making it easy for you to secure the keys to your dream car. Once you are on the road, our insurance products offer you comprehensive protection on

every trip. Finally, our service products ensure that your car is always in tip-top condition whilst keeping costs transparent and easily manageable. For a detailed quotation, please contact your Mercedes-Benz dealer, who will be glad to go through the latest financial services and terms and conditions with you.

Mercedes-Benz mobility. Your new car comes complete with the promise of feeling safe on the road, but if you should ever need assistance, then Mercedes-Benz Service24h is there to help. Just call the freephone service hotline on 00800 1 777 7777². The integrated telematics service, Mercedes-Benz Contact³, is even more customer friendly: a touch of a button is all it takes to contact the Mercedes-Benz customer centre. If you wish, the relevant vehicle and position-related data can be transmitted at the same time, thereby allowing the centre to react quickly and provide rapid on-the-spot assistance. Also standard with your new car at no extra

charge is the Mercedes-Benz Mobilo⁴ mobility package. Whether you have lost your key, had a breakdown which cannot be repaired immediately or suffered damage to the vehicle due to an accident or vandalism, Mobilo is there to help you reach your destination – anywhere in Europe. Whatever your problem, one thing is certain: you will soon be able to resume your journey.

Mercedes-Benz Museum. Experience 125 years of automotive history against an architecturally impressive backdrop. Over 1500 exhibits on nine levels give you an insight into the unique tradition and powers of innovation of the Mercedes-Benz brand in Stuttgart. See the world's first two automobiles in the shape of the Benz Patent-Motorwagen (motor car) and the Daimler motorised carriage – plus the automotive future of Mercedes-Benz – in an area covering a total of 16,500 square metres. We look forward to your visit – online, too, at www.mercedes-benz-classic.com/museum

¹ Information about the MercedesCard in Austria and Switzerland can be found on the Mercedes-Benz websites for these countries ² Alternative: +49 69 95 30 72 77. The only charge incurred is the cost of the mobile phone call to the landline network

Test drive. The unique feeling of driving a Mercedes cannot be put into words. Which is why we'd like to invite you to experience it for yourself. Take a test drive and find out first hand how it feels to drive your dream car. Simply visit www.mercedes-benz.com to locate your nearest Mercedes-Benz dealer.

Interactive Owner's Manual. The website also offers an interactive tour, enabling you to take a closer look at your desired model. Experience key functions in detail, gain an insight into the car's inner workings or look at the benefits of each model at www.mercedes-benz.de/owners-manual

Mobile internet. Now you can access the entire world of Mercedes-Benz from your mobile phone. As well as an overview of all the passenger car models, there are insights into the entire brand world along with a wealth of entertainment offers and direct links to our range of services at www.mercedes.mobi

Service packages. Vehicle-specific services allow you to put together an individual package for your Mercedes-Benz: for a small monthly premium the Excellent service package covers all service jobs including maintenance, wear and repairs – for up to five years. Simply present your service card to avoid any financial surprises. And you can be sure that your Mercedes-Benz will remain on top form for a long time to come. With the Advance service package it will stay at its best for longer still: you are protected against unexpected repair costs even after the manufacturer's warranty or the service package has expired – for up to ten years.



Repair following an accident. Should the worst come to the worst, the Mercedes-Benz accident repair service provides you with the best help available for your vehicle, which will retain its valuable safety properties. From work on the paint to bodywork or glass damage – optimally trained specialists will repair your Mercedes-Benz at your Mercedes-Benz service partner, and you will soon be back on the road again. Further information is available from your authorised Mercedes-Benz dealer.



Dimensions

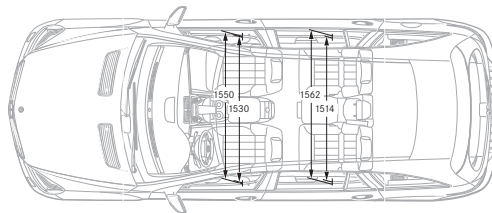
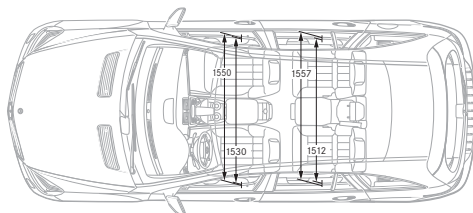
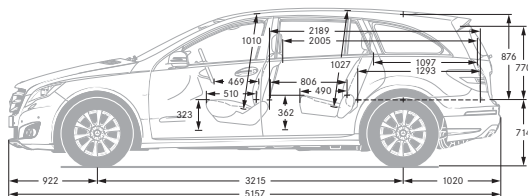
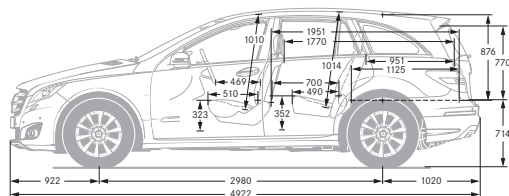
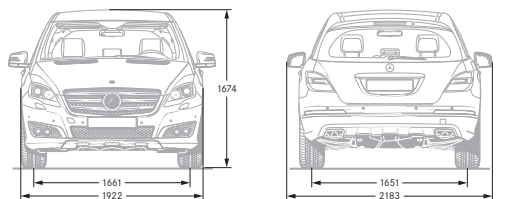

The R-Class

Long-wheelbase version of the R-Class

All measurements in millimetres. The dimensions shown are mean values and apply to standard-specification, unladen vehicles

Paintwork

NON-METALLIC PAINTS (standard)

- 040 black
- 650 calcite white

METALLIC PAINTS (option)

- 197 obsidian black
- 359 tanzanite blue
- 755 tenorite grey
- 775 iridium silver
- 792 palladium silver
- 794 pearl beige
- 796 citrine brown
- 799 diamond white metallic BRIGHT

Technical data

No. of cylinders/arrangement
Total displacement (cc)
Rated output ¹ (kW at rpm)
Rated torque ¹ (Nm at rpm)
Compression ratio
Acceleration from 0–100 km/h (s) (long wheelbase)
Top speed approx. (km/h) (long wheelbase)
Tyre size, front
Tyre size, rear
Fuel
Fuel consumption ^{2, 5} (l/100 km)
Urban (long wheelbase)
Extra-urban (long wheelbase)
Combined (long wheelbase)
CO ₂ emissions ^{2, 5} (g/km) combined (long wheelbase)
Efficiency class
Emission class (long wheelbase)
Tank capacity (l)/incl. approx. reserve
Boot capacity (l) (long wheelbase)
Turning circle diameter (m) (long wheelbase)
Kerb weight ^{3, 5} (kg) (long wheelbase)
Perm. GVW ⁵ (kg) (long wheelbase)

DIESEL ENGINES

R 300 CDI BlueEFFICIENCY	R 350 CDI 4MATIC	R 350 BlueTEC 4MATIC
6/V	6/V	6/V
2987	2987	2987
140/3800	195/3800	155/3400
440/1400–2800	620/1600–2400	540/1600–2400
15.5 : 1	15.5 : 1	16.5 : 1
9.5 (-)	7.6 (7.7)	- (8.9)
215 (-)	235 (235)	- (220)
235/65 R 17	255/55 R 18	235/65 R 17
235/65 R 17	255/55 R 18	235/65 R 17
Diesel	Diesel	Diesel
9.9–9.6 (-)	11.0 (11.0)	- (11.0)
6.7–6.4 (-)	7.0 (7.0)	- (7.0–6.9)
7.8–7.6 (-)	8.5 (8.5)	- (8.5–8.4)
206–199 (-)	223 (223)	- (223–222)
C (-)	D (D)	- (C)
Euro 5 (-)	Euro 5 (Euro 5)	- (Euro 6)
80/13.0	80/13.0	80/13.0
550–1950 (-)	550–1950 (633–2385)	- (633–2385)
11.8 (-)	11.8 (12.6)	- (12.6)
2185 (-)	2250 (2295)	- (2340)
2840 (-)	2880 (2910)	- (2910)

¹ Figures in accordance with Directive 80/1269/EEC in the currently applicable version ² The figures shown were obtained in accordance with the prescribed measuring process (Directive 80/1268/EEC in the currently applicable version). The figures are not based on an individual model and do not constitute part of the product offer; they are provided solely for purposes of comparison between different vehicle models

PETROL ENGINES

R 350 4MATIC BlueEFFICIENCY

R 500 4MATIC

No. of cylinders/arrangement	6/V	8/V
Total displacement (cc)	3498	5461
Rated output ¹ (kW at rpm)	225/6500	285/6000
Rated torque ¹ (Nm at rpm)	370/3500–5250	530/2800–4800
Compression ratio	12.0 : 1	10.7 : 1
Acceleration from 0– 100 km/h (s) (long wheelbase)	7.8 (7.9)	– (6.3)
Top speed approx. (km/h) (long wheelbase)	245 (245)	– (250 ⁴)
Tyre size, front	255/55 R 18	255/50 R 19
Tyre size, rear	255/55 R 18	255/50 R 19
Fuel	Premium petrol	Premium petrol
Fuel consumption ^{2, 5} (l/100 km)		
Urban (long wheelbase)	13.2 (13.3)	– (18.8–18.6)
Extra-urban (long wheelbase)	8.1 (8.2)	– (10.2–10.0)
Combined (long wheelbase)	10.0 (10.1)	– (13.4–13.2)
CO ₂ emissions ^{2, 5} (g/km) combined (long wheelbase)	233 (235)	– (311–306)
Efficiency class	E (D)	– (G)
Emission class (long wheelbase)	Euro 5 (Euro 5)	– (Euro 5)
Tank capacity (l)/incl. approx. reserve	80/13.0	80/13.0
Boot capacity (l) (long wheelbase)	550–1950 (633–2385)	– (633–2385)
Turning circle diameter (m) (long wheelbase)	11.8 (12.6)	– (12.6)
Kerb weight ^{3, 5} (kg) (long wheelbase)	2180 (2235)	– (2265)
Perm. GVW ⁵ (kg) (long wheelbase)	2840 (2880)	– (2920)

³ Figures in accordance with Directive 92/21/EC, version 95/48/EC (kerb weight with fuel tank 90% full, driver, 68 kg, and luggage, 7 kg) for standard-specification vehicles. Optional extras and accessories will generally increase this figure and reduce the payload capacity accordingly ⁴ Electronically governed ⁵ Figures refer to 5-seater Further technical data can be found at www.mercedes-benz.com

NON-METALLIC PAINTS

METALLIC PAINTS

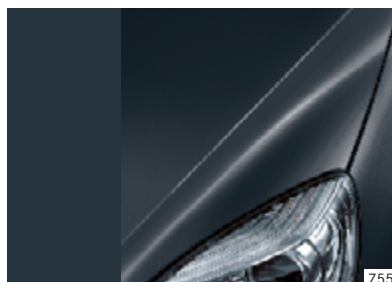
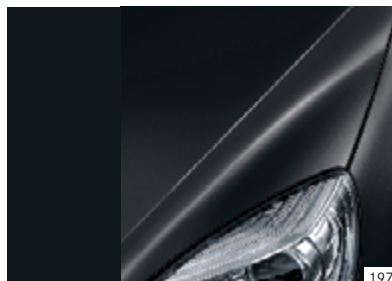

Take-back of end-of-life vehicles. Coming full circle. At the end of its long life, you can return your R-Class to us for environment-friendly disposal in accordance with the EU End-Of-Life Vehicle Directive¹. But that day lies a long way off.

¹ Applies in accordance with national regulations to vehicles up to 3.5 tonnes gross weight. Mercedes-Benz passenger cars have met the statutory regulations governing the suitability of their design for reuse and recycling for a number of years now. A network of vehicle take-back depots and dismantlers has been established which will process your vehicle in an environment-friendly manner. The ways in which both vehicles and parts can be recovered are subject to ongoing development and improvement. Consequently, the R-Class will be able to comply with any future increases in the recycling quota within the stipulated time limits. For further information:

www.mercedes-benz.com

Please note: changes may have been made to the product since this brochure went to press (22.07.2011). The manufacturer reserves the right to make changes to the design, form, colour and specification during the delivery period, provided these changes, while taking into account the interests of the vendor, can be deemed reasonable with respect to the purchaser. Where the vendor or the manufacturer uses symbols or numbers to describe an order or the subject of an order, no rights may be derived solely from these. The illustrations may show accessories and items of optional equipment which are not part of standard specification. Colours may differ slightly from those shown in the brochure, owing to the limitations of the printing process. This brochure is distributed internationally. It provides a general indication of the range of models, features, optional extras and/or colours available in various countries. Some of the models, features, optional extras and/or colours may not be available in your country, or may only be available in a different specification. Additionally some models, features, optional extras and/or colours may only be available in combination with others. For current and more specific information in relation to the range of models, features, optional extras and/or colours available in your country, and their pricing, you should contact your nearest authorised Mercedes-Benz Passenger Car Dealer. www.mercedes-benz.com