

This Brochure is prepared by Daimler AG and it predominantly reflects the capabilities and performance of vehicles sold in Europe. Some characteristics, capabilities, performance features and optional extras (e.g. towing systems) may not be available or may not apply in Australia or under Australian conditions. The information in this Brochure is therefore indicative, illustrative and provided only for guidance and should not be relied on. To obtain current and accurate information on a vehicle and any options applicable to Australia, contact your local authorised Mercedes-Benz dealer.



Mercedes-Benz

# The S-Class



Mercedes-Benz





missions for the S-Class and developing an intelligent hybrid engine is anything but twisting, lonely and narrow. The thing that matters most, however, is a calm pulse and clear thoughts are inner signs of composure. It's good to know that the sensors and numerous electronic systems in the S-Class do for you whilst you are driving. You saw these upright humans turn into sedentary creatures, which means that the old saying about a trip into the blue could have its origins in billowing fields. You stay this relaxed – albeit at a brisker pace – on the road today, there is the ability to notice that which would normally go unnoticed. “I feel, therefore I am.” As by the shape, structure and strong looks of the S-Class. Even the most demanding heavy loads. **An automotive icon.** Then you place your hands on the steering wheel. More than anything else. What do we hear when we hear nothing? Ourselves, our

## From road to memory

Our cars have epitomised luxurious mobility since the beginning of the 20<sup>th</sup> century. And they have thrilled generations of motorists who have style and great expectations.

The direct line of ancestors of the S-Class began in 1951 when the 6-cylinder Mercedes-Benz 220 model appeared at the first International Motor Show in Frankfurt. Even this very first model boasted a high standard of equipment and delivered effortlessly superior performance. Launched in 1972, the W 116 was the first S-Class, as it became known, and the official Mercedes-Benz representative in the luxury segment.

Outstanding comfort, innovative technology and comprehensive safety features have been characteristic traits of the luxury saloon ever since. Crumple zones, ABS, airbags and ESP® – they are all trailblazing innovations in the history of automotive development. And they all began life in the S-Class. Before finding their way into many other models and vehicle categories and, therefore, into people's minds and the history books.

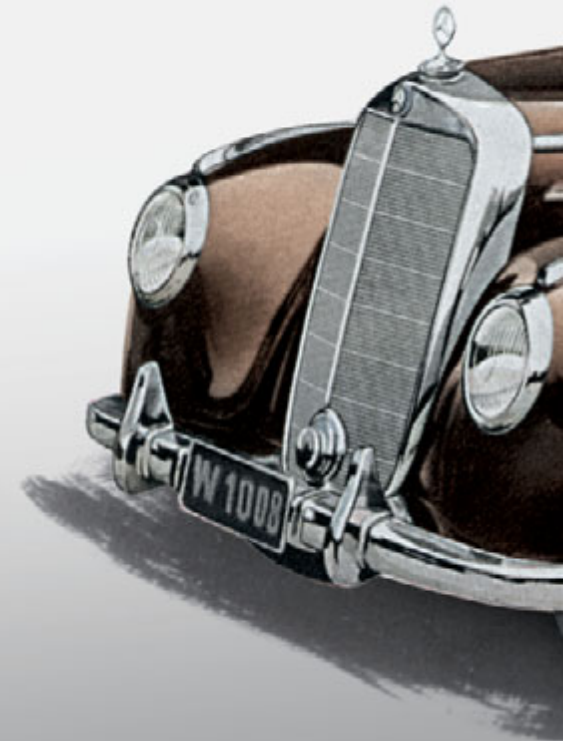





The S-Class is the benchmark for future mobility. Just as it has been for generations. Featuring innovations aimed at enhancing comfort, safety and environmental compatibility, it has become a role model and a showcase car for the entire automotive industry. The ninth generation also lives up to this billing: it includes the world's first standard-production hybrid vehicle with a lithium-ion battery as well as fuel consumption and emission-reducing measures across the

whole range, to name but two reasons. Furthermore, numerous sensors and intelligent electronic systems set milestones in terms of occupant protection, driving assistance and entertainment. Last but by no means least, its sophisticated, terse appearance underlines its role on the road with effortless superiority. Like its forebears, the latest S-Class leaves no doubt: when it comes to mobility, it is the one true icon.

At a glance | from page 6    Insight | from page 28

#### Featured models:

**S 500 | dolomite brown metallic** | Cover and from page 6  
Multi-spoke light-alloy wheels, sahara beige/black Exclusive PASSION Leather package, high-gloss light brown burr walnut wood trim

**S 600 | obsidian black metallic** | From page 21  
5-spoke light-alloy wheels, cashmere beige/savanna beige Exclusive PASSION leather package, high-gloss brown poplar wood trim

The illustrations may show accessories and items of optional equipment which are not part of standard specification





**Comfort-oriented driving pleasure:** S 400 HYBRID, diesel and petrol engines, transmissions, chassis and suspension.

Drive system & chassis | from page 36

**Maximum safety:** active and passive safety technologies.

Safety | from page 48

**Experience the essence of relaxed driving:** light, multimedia and assistance systems, climate control and seats.

Comfort | from page 52

**The right S-Class for every situation:** long-wheelbase version, S 600, S-Guard and S 600 Pullman Guard.

Model variants | from page 64

**Powerful AMG saloons:** the S 63 AMG and S 65 AMG models.

AMG | from page 72

**S-Class individuality:** standard equipment and optional extras, AMG Sports package, designo, upholstery and trim, wheels and genuine accessories.

Equipment & appointments | from page 78

**Star service:** MercedesCard, Mercedes-Benz Financial Services, Mercedes-Benz mobility, Mercedes-Benz Museum, test drive, Interactive Owner's Manual, mobile internet, service packages, accident repairs.

Services | from page 96

**To be precise:** technical data, dimensions and paintwork.

Facts & colours | from page 98



**Power | The product of class and acceleration**

It's truly inspiring to see someone achieve so much with so little effort. The same benchmark will also apply to mobility in future. Reducing fuel consumption and CO<sub>2</sub> emissions for the S-Class and developing an intelligent hybrid engine is anything but idealism – it is progress.

→ Page 38

**Grace | Making light of every road**

Each route has its own character. Sometimes they are generous, inviting, imposing. Sometimes they are twisting, lonely and narrow. The thing that matters most, however, is how they are negotiated. The best approach: choose a car that lets you stay – and look – relaxed and in control.





**Meditation | Concentrated relaxation**

Steady breathing, a calm pulse and clear thoughts are inner signs of composure. It's good to have some outside assistance to help ensure the necessary serenity - by reducing many of the risks. Just as nearly a hundred sensors and numerous electronic systems in the S-Class do for you whilst you are driving. → Page 48











### **Seats | The most comfortable way to travel**

As humans learned to walk on two legs, the body evolved into the perfect walking machine. The dawn of the modern age saw these upright humans turn into sedentary creatures, which means that it is all the more important to make this seated posture as natural as possible. With features such as ergonomic, active seats. → Page 62







### **Touring | The world's your oyster**

The old saying about a trip into the blue could have its origins in billowing fields of light-blue flax in full bloom. When the phrase was born, people were still chauffeured by a single horsepower. To help you stay this relaxed – albeit at a brisker pace – on the road today, there is the S-Class. A car that sets new safety standards thanks to assistance systems that help you observe the surroundings and give you the ability to notice that which would normally go unnoticed. → Pages 48, 58











**Emotions | One of the best ingredients of all**

“I feel, therefore I am” – in times such as these, in which even vehicles are part of the thinking process, it is about more than this: you also have to feel moved. As by the shape, structure and strong looks of the S-Class. Even the most intelligent of cars should always speak initially to the heart.





**Etiquette | An instinctive feeling for the road**

You'd think that power was the most important thing when moving heavy loads. Then you place your hands on the steering wheel. And feel the road and the lightness with which the several hundred horsepower glide over it. Then you realise: the S-Class is driven by culture more than anything else.

→ Page 40, 42





A dark blue Mercedes-Benz S-Class sedan is shown from a front-quarter perspective, parked on a sandy beach. The car's iconic grille, headlights, and Mercedes-Benz emblem are clearly visible. The license plate reads 'S PE 4501'. In the background, a large, smooth sand dune rises against a cloudy sky. The overall mood is serene and minimalist.

**Calm | The whisper of the tarmac**

What do we hear when we hear nothing? Ourselves, our natural frequency, the blood in our veins? There is no better place than the S-Class to experience this.

# Road

**TV and driving don't mix. Or do they?** A cinema screen on one side and a navigation display on the other? A single monitor on which two people can watch two completely different things at the same time even though they are sitting side by side? Sounds like a dream of the future. But it is here now. And it is called SPLITVIEW. An innovative technology used in the S-Class. Bringing a whole new dimension to on-screen presentation.



# Movie

SPLITVIEW allows the driver and front passenger to watch two feeds from different media at the same time – with a full screen diagonal – as if each had their own screen. So the driver can view the route recommended by the navigation system, while the front passenger can lose themselves in the infinite beyond of a galaxy far, far away.



# Those who dare

Less

What do you get when the energy of millions of ions is used as a power source? An extremely eco-friendly drive system.

We speak from experience, since Mercedes-Benz was the world's first manufacturer to begin installing a lithium-ion battery in a series-production car – the S 400 HYBRID. Dispensing with conventional technology in this way benefits both the S-Class and its drivers: the compact battery means that even the hybrid variant boasts the impressive boot capacity for which the S-Class is renowned. What's more, the energy density in the lithium-ion

# win

means more

batteries is higher than in conventional nickel-cadmium batteries, for example. So the battery condenses greater power reserves within a small space yet weighs less, all of which has a positive effect on fuel consumption. And lower fuel consumption means fewer emissions – another benefit for the environment.

If all this seems a little too rational, we are pleased to announce that, thanks to its intelligent drive system, the S 400 HYBRID with a lithium-ion battery is not only sensible but also extremely powerful and dynamic.





systems. Upholstery and trim. In the event of an accident. Metallic paints. Suspension. Optional extras. Fuel consumption. Interior. In the event of danger. Standard equipment. Light. Multimedia systems. Drive system. Genuine accessories. Wheels. Interior. Safe driving. CO<sub>2</sub> emissions. Upholstery and trim. Safety paints. Petrol engines. Sound system. AMG. Acceleration. Design. Emissions. In the event of danger. LED daytime driving lights. Engines. Paintwork. Total displacement. Genuine accessories. Test drive. Equipment & appointments. CO<sub>2</sub> emissions. BlueEFFICIENCY. Comfort. Cylinder. Technical data. Interior. Services. Sound. Design. Emissions class. Safe driving. Light-alloy wheels. Top speed. Optional extras. Engines. AMG. **The facts.** Paintwork. Total displacement. Climate control. Genuine accessories. Test drive. Equipment & appointments. Light-alloy wheels. M

36 **BlueEFFICIENCY**

37 **Environment, efficiency  
and S-Class**

38 **S 400 HYBRID**

40 **Diesel engines**

4-cylinder

6-cylinder

42 **Petrol engines**

6-cylinder

8-cylinder

12-cylinder

44 **Transmission**

7G-TRONIC/7G-TRONIC PLUS

5-speed automatic transmission

46 **Chassis & suspension**

AIRMATIC

Active Body Control ABC

4MATIC all-wheel drive

48 **Safe driving**

ATTENTION ASSIST

Adaptive Highbeam Assist

Night View Assist Plus

Driving Assistance package Plus

50 **In the event of danger**

PRE-SAFE® Brake and BAS PLUS

PRE-SAFE® system

51 **In an accident**

NECK-PRO head restraints

Airbags

52 **Light**

Headlamps

Tail lights

LED Light package

Ambient lighting

54 **Multimedia systems**

COMAND APS

SPLITVIEW

Rear Seat Entertainment package

56 **High-end sound system**

58 **Assistance systems**

Parking package

Speed Limit Assist

60 **Climate control**

62 **Seats**

Front Seat Comfort package

Rear Seat Comfort package

Rear Seat Memory package

64 **Long-wheelbase version**

66 **S 600**

68 **S-Guard**

70 **S 600 Pullman Guard**

# S-Class in detail

72 **S 63 AMG**74 **S 63 AMG technology**

AMG 5.5-litre V8 engine

AMG SPEEDSHIFT MCT

7-speed sports transmission

76 **S 65 AMG**78 **Standard equipment**79 **Optional extras**80 **AMG Sports package**82 **designo**

Individualisation options

designo Selection

86 **Upholstery and trim**92 **Wheels**94 **Genuine accessories**96 **Services**

MercedesCard

Mercedes-Benz Financial Services

Mercedes-Benz mobility

Mercedes-Benz Museum

Test drive

Interactive Owner's Manual

Mobile internet

Service packages

Accident repairs

98 **Dimensions**98 | 101 **Paintwork**99 **Technical data**

## BlueEFFICIENCY – fast forward to tomorrow



Mercedes-Benz is quicker at getting future technologies to where they matter most: on the road. By the end of 2012, more than 140 Mercedes-Benz models will be available with BlueEFFICIENCY technologies, all of which help you reduce your impact on the environment. Our BlueEFFICIENCY concept comprises innovations for efficient mobility as well as optimised processes all the way along the value chain.

**The BlueEFFICIENCY measures – the Mercedes-Benz efficiency package.** This package consists of comprehensive vehicle optimisations designed to ease the burden on the environment. Each model combines the most efficient engine with latest-generation, intelligent aerodynamic and energy-management measures. Such measures include the ECO start/stop function, which is available for an increasing number of models. The BlueDIRECT V6 and V8 petrol engines, which feature in several model series, deliver a much higher power output while reducing fuel consumption by up to 25%.

**BlueTEC – the clean diesel.** A modular emission-control system makes BlueTEC an exceptionally clean diesel technology. As well as removing 95% of the particulate, it also reduces nitrogen oxides by up to 90%. What remains is mainly water and nitrogen.

**HYBRID – petrol and electric drives intelligently combined.** Here the electric motor can be used both for accelerating and for recuperating braking energy, which is stored in the battery. What's more, the ECU shuts off the petrol engine when the speed is below 15 km/h. In this way, a HYBRID can achieve significant fuel savings.

**BlueTEC HYBRID – clean diesel combined with electric drive.** It marries the benefits of the HYBRID with those of BlueTEC: during braking, the kinetic energy is converted into electrical energy, which can be re-used when required. At the same time, the BlueTEC technology cleans the exhaust gases and removes many of the pollutants. All of which makes the

economical diesel powerplant even more efficient and clean.

**Innovative drive systems that break new ground: E-CELL and F-CELL.** We have developed two locally emission-free drive systems which have been produced on a small scale since 2010. The B-Class F-CELL<sup>1</sup> uses hydrogen to produce power for the electric motor, while the A-Class E-CELL<sup>1</sup> draws its energy directly from two lithium-ion batteries.

But that is not all: under the banner “Design for Environment”, we also look at a vehicle's entire lifecycle and work hard to preserve the environment from the planning stage right through to recycling. In addition, we are involved in the development of alternative fuels and carry out research in the field of bionics. Further information about our comprehensive measures can be found at [www.mercedes-benz.com/blueefficiency](http://www.mercedes-benz.com/blueefficiency)

<sup>1</sup> Provisional figure: efficiency class: A++

The figures are not based on an individual vehicle and do not constitute part of the product offer; they are provided solely for the purposes of comparison between the different vehicle models



## Environment, efficiency and S-Class

A role model for innovation since its inception, the S-Class is forging unique paths when it comes to sustainability and environmental protection: with enhanced efficiency and a hybrid vehicle featuring lithium-ion technology

The S-Class features clean and efficient engines as well as sustainable technology – and not just under the bonnet. Aerodynamic measures, tyres with optimised rolling resistance and an intelligent energy-management system help to reduce

fuel consumption and CO<sub>2</sub> emissions. Energy is used efficiently, saved wherever possible and – as in the case of the S 400 HYBRID – stored and fed back into the system at another point. The S 350 BlueTEC model boasts one of the cleanest

diesel technologies in the world, while the S 400 HYBRID achieves emission figures that comply with the levels demanded by the world's most stringent standards.



- 1 Specially designed tyres for optimised rolling resistance
- 2 Euro-5 certification for all petrol engines
- 3 S 400 HYBRID with V6 petrol engine and electric motor as well as recuperative braking system (for recovering braking energy) and ECO start/stop function
- 4 Aerodynamically styled exterior mirror housings
- 5 Energy-saving control of auxiliary units (power steering pump as well as oil and water pumps)
- 6 Car always starts with transmission in “E” (Economy) mode
- 7 Sealed joints around the headlamps for improved aerodynamics
- 8 S 350 BlueTEC has one of the world's cleanest diesel technologies (corresponds to Euro 6 emissions standard)

The measures vary depending on model and market

## S 400 HYBRID

Ecofriendly motoring with a powerful hybrid drive system, comprising a 6-cylinder petrol engine backed by an electric motor

The S 400 HYBRID<sup>1</sup> is driven by a powerful 6-cylinder petrol engine backed by a high-torque electric motor. In addition, optimised aerodynamics, recuperation of kinetic energy, the



Energy flow display in the S 400 HYBRID model

ECO start/stop function and low rolling-resistance tyres make this an efficient car. And it offers the familiar high level of ride comfort, the full boot capacity, a luxurious interior atmosphere and impressive agility. This is ensured by the boost function, which briefly concentrates the power of both drive units.

At the heart of the S 400 HYBRID is an extremely light and small hybrid module with a peak torque of 160 Nm, which supports the 6-cylinder petrol engine. Optimum interaction between the internal combustion engine and the electric module is controlled by the power electronics.

A specially developed lithium-ion battery drives the hybrid module – in the S 400 HYBRID this was the very first time this combination was implemented in a series-production car. This battery is supplied by the recuperative braking system when braking. The current flow of energy from the electric motor or internal combustion engine is shown on a hybrid display in the instrument cluster and on the COMAND display. At traffic lights, for example, the ECO start/stop function switches off the internal combustion engine in the S-Class. Stored electrical energy is then used to restart the car as normal.

<sup>1</sup> Not available as right-hand-drive version

- 1 The efficiency-optimised 6-cylinder petrol engine with a displacement of 3.5 litres
- 2 The hybrid module, in the shape of a compact electric motor, is located between the petrol engine and the automatic transmission
- 3 The powerful lithium-ion battery has a high energy density yet its dimensions are compact and it is light in weight
- 4 The power electronics coordinate the intelligent and efficient work performed by the petrol engine and electric drive system
- 5 The optional 7G-TRONIC PLUS automatic transmission ensures imperceptible switching between the power sources and acceleration without interruption of tractive power
- 6 Recuperative braking system: when braking, the electric motor becomes a generator and produces electrical current for the lithium-ion battery
- 7 Low rolling-resistance tyres for comfortable and economical motoring
- 8 The energy flow and drive system battery charge level are indicated constantly on the hybrid display

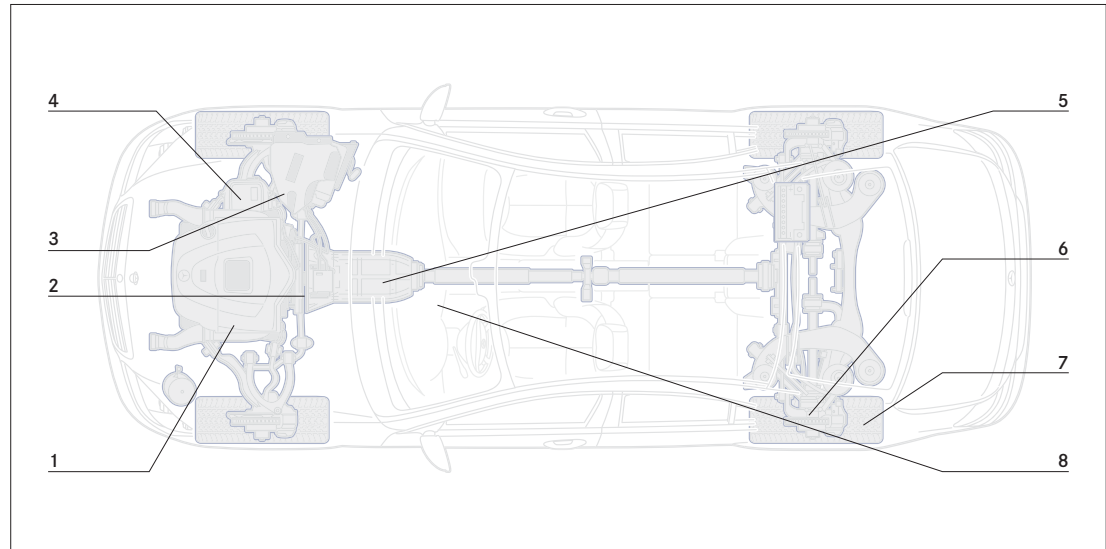

The hybrid components of the S 400 HYBRID in detail

# Diesel engines

The consumption- and emission-optimised diesel engines for the S-Class are characterised by power, refinement and efficiency

**4-cylinder diesel engine.** The S 250 CDI BlueEFFICIENCY impresses with its powerful, efficient 4-cylinder diesel engine. It can accelerate

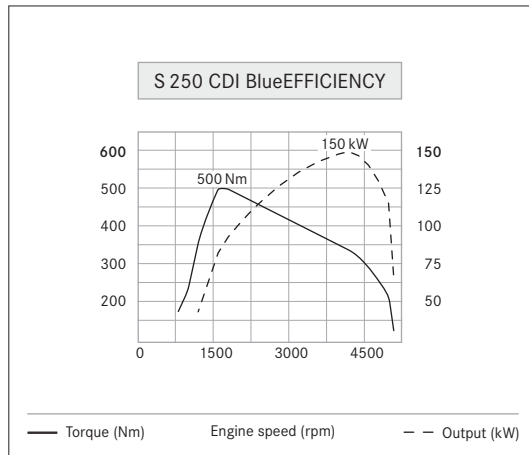

Peak torque: 500 Nm at 1600–1800 rpm

from 0 to 100 km/h in 8.2 seconds, and with a rated output of 150 kW consumes only 5.8–5.7 l/100 km. In addition, with a CO<sub>2</sub> emissions level of 151–149 g/km it is among the lowest-emission diesel engines in the luxury-saloon class.

**6-cylinder diesel engine.** The sophisticated BlueTEC technology in the S 350 BlueTEC developing 190 kW has extremely low emissions. BlueTEC stands for measures aimed at optimising fuel consumption and for the cleaning and after-treatment of exhaust gases. All of which gives this compression-ignition model one of the world's cleanest diesel drive systems. Further hallmarks of the S 350 BlueTEC include exemplary emission figures, which already meet the requirements of future emissions standards (Euro 6), low fuel

consumption, effortlessly superior performance and a high torque of 620 Nm.

Both diesel engines – the S 250 CDI BlueEFFICIENCY and the S 350 BlueTEC without 4MATIC – feature the ECO start/stop function as standard. What's more, a particulate filter significantly reduces particulate emissions in both models.



The ECO start/stop function also contributes to the excellent consumption figures of the S250 CDI – outstanding in its class

## Petrol engines

The S-Class petrol engines combine intense driving pleasure with low environmental impact more effectively than ever. The V6 and V8 engines with direct injection set the standard in terms of efficiency and performance. The optimised 12-cylinder power plant in the S 600<sup>1</sup> complies with the requirements of the Euro 5 emissions standard

**6-cylinder petrol engine.** The V6 power unit features spray-guided direct petrol injection with piezo injectors, four valves per cylinder

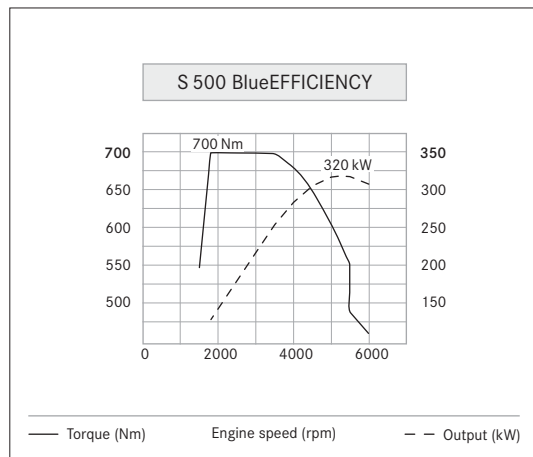

Minimum revs, maximum reserves

<sup>1</sup> Available as long-wheelbase version only

and adjustable camshafts. For the S 350 BlueEFFICIENCY this means lower fuel consumption, fewer CO<sub>2</sub> emissions and even greater refinement. Its output is 225 kW, while it delivers its peak torque of 370 Nm at 3500 rpm.

**8-cylinder petrol engines.** This engine excels, on the one hand, with fuel consumption that is up to 15% lower than that of the predecessor model. On the other, despite its low consumption, the engine performance is significantly higher thanks to twin turbocharging with intercooling. A power output of 320 kW, maximum torque of 700 Nm on tap from just 1800 rpm, plus acceleration from 0 to 100 km/h in 5.0 seconds mean effortlessly superior motoring in every driving situation.

The ECO start/stop function integrated in the 6- and 8-cylinder petrol engines also helps you save fuel when waiting at traffic lights or in a traffic jam.

**12-cylinder petrol engine.** The measure of all engines – offering outstanding refinement, spontaneous power delivery and sublime sound. Not only that, it is also highly efficient and a technical masterpiece. The V12 biturbo engine achieves its peak torque of 830 Nm before even reaching the 2000 rpm mark. And it takes just 4.6 seconds to accelerate from 0 to 100 km/h thanks to its 380 kW output.

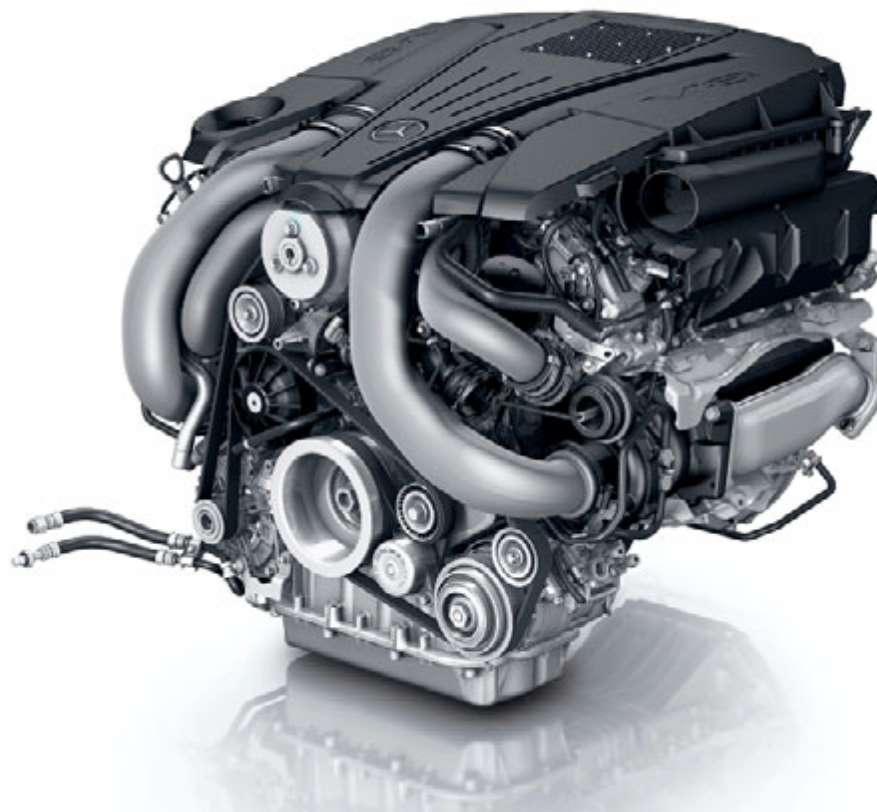

Efficient technology featuring high-pressure direct injection with piezo injectors in the V8 petrol engine

# Transmission

Whatever your driving style – economical or sporty – the S-Class transmissions have been optimised with your needs firmly in mind



The DIRECT SELECT lever on the steering wheel

**7G-TRONIC and 7G-TRONIC PLUS.** Many of our V6 and V8 engines, as well as the 4-cylinder diesel engine in the S 250 CDI, are equipped with the 7G-TRONIC PLUS enhanced 7-speed automatic transmission as standard to provide for optimum fuel consumption. Both transmission systems are controlled by means of the DIRECT SELECT lever on the steering column. With seven forward gears, these systems allow an optimum engine speed, thus reducing the amount of fuel used. Short and smooth gear changes make for supreme ease of shifting and low noise levels. A set-up switch enables

the driver to choose from three modes: Manual, Comfort or Sport. Manual gearshifts are performed using steering-wheel gearshift paddles – similar to those used in motorsport.

**5-speed automatic transmission.** This transmission is the perfect complement to the 12-cylinder engine's characteristics. Gear changes are so fast and smooth that they are barely perceptible, while just the right amount of power is delivered for every situation. A manual gearshift option is available if required.



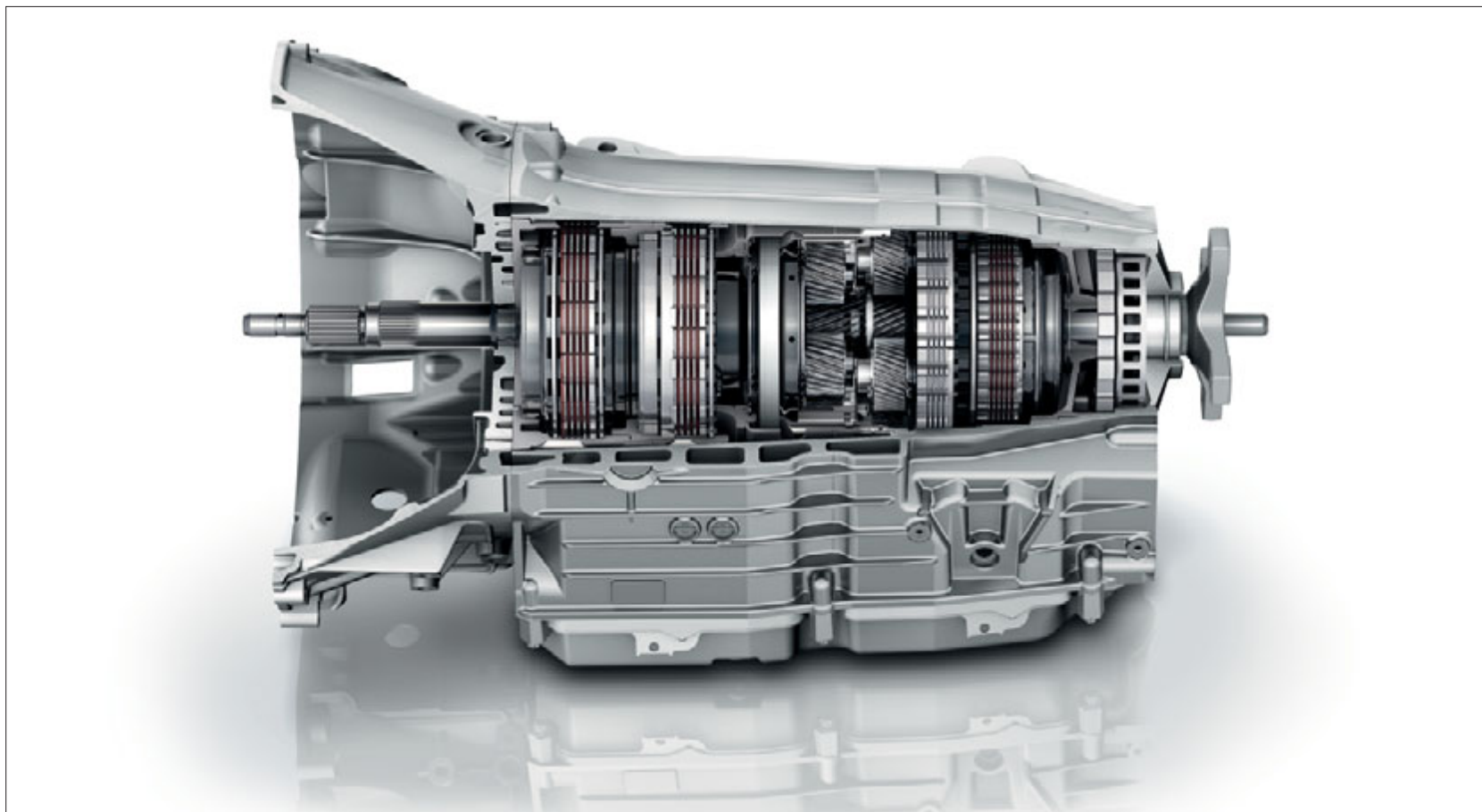

The 7G-TRONIC PLUS: the result of more than 50 years of experience in the development of automatic transmissions

## Chassis & suspension

**Comfort is omnipresent – thanks to precision-tuned chassis and suspension components as well as powerful all-wheel drive**

The AIRMATIC air suspension, fitted as standard, and Active Body Control ABC with crosswind stabilisation make for high levels of comfort and agility as they adjust the chassis and suspension settings to suit the current situation with minimum fuss. Sporty suspension settings are selected for dynamic driving, while a more comfort-oriented setting is adopted for leisurely cruising.

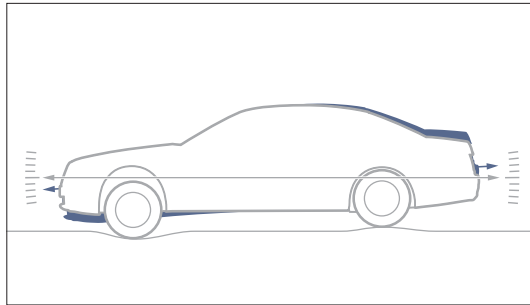

AIRMATIC air suspension improves ride comfort, particularly on poor road surfaces

ABC uses microprocessor-controlled suspension struts to reduce the car body's lift, pitch and roll. It counteracts these movements by selectively raising or lowering the chassis. The same process is employed to reduce body movements when pulling away and braking. Hence ABC ensures best-possible roadholding, agility, dynamism and an effortlessly superior driving feel in virtually

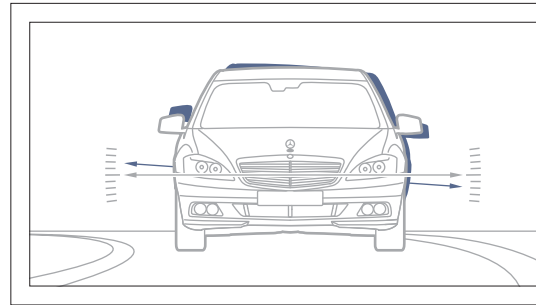

ABC ensures an extremely agile and dynamic driving feel, while crosswind stabilisation improves handling by actively influencing the wheel forces

every driving situation. Crosswind stabilisation, meanwhile, can compensate for the effect of crosswinds, by distributing the wheel load, and helps to maintain directional stability, even in stormy weather. ABC with crosswind stabilisation is fitted as standard on the S 600<sup>1</sup> and AMG models and as an optional extra on the S 500 BlueEFFICIENCY.

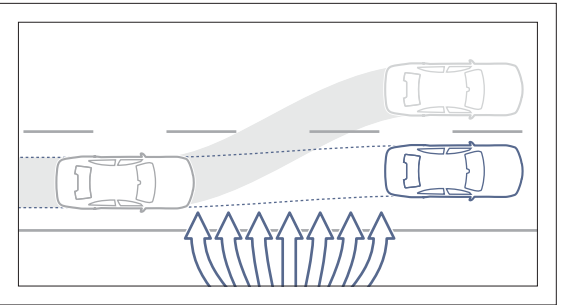

<sup>1</sup> Available as long-wheelbase version only

**4MATIC.** The permanent all-wheel-drive system distributes the engine power to both axles at a fixed ratio of 45% to 55% – equalling 100% traction. To this end, 4MATIC uses the Electronic Stability Program ESP® and the electronic traction system 4ETS. The latter enables controlled braking of spinning wheels and, as a consequence, increases the drive torque at the wheels that have good

traction. This helps ensure plenty of power is planted on the road when moving off and when accelerating, especially on poor road surfaces. Automatic braking pulses make it easier to move off on slippery surfaces as well as enhancing stability during critical manoeuvres. A further advantage of the system is the fact that it is hardly any heavier than the rear-wheel-drive

version on account of the compact design, intelligent choice of materials and high level of efficiency. 4MATIC is only available in conjunction with the 7G-TRONIC PLUS automatic transmission.

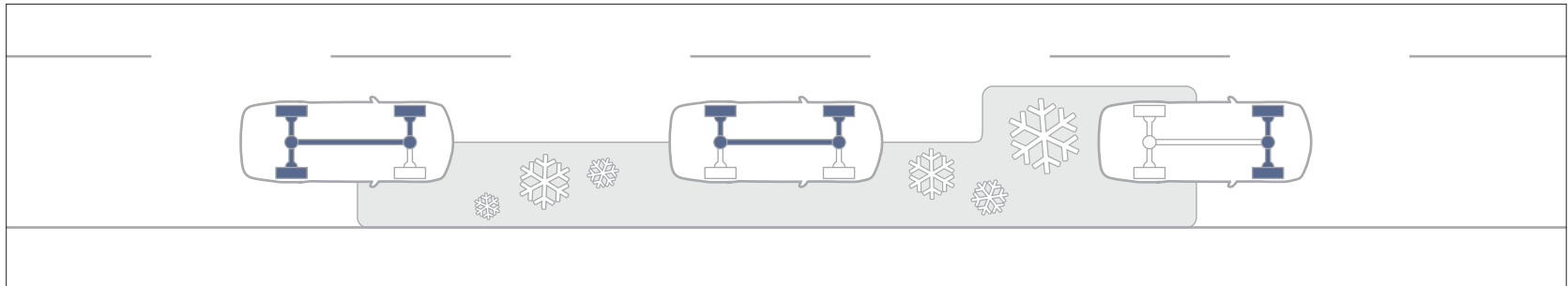

The electronic traction system 4ETS automatically sends the drive torque to the wheels offering sufficient traction

## Safe driving

Assistance systems help to detect and defuse critical situations and, therefore, prevent accidents wherever possible

**ATTENTION ASSIST** (standard)<sup>1</sup>. This drowsiness detection system is useful on long trips. At speeds of between 80 and 180 km/h, ATTENTION ASSIST can warn the driver as soon as it detects signs of inattention. To this end, several sensors analyse driving behaviour on a permanent basis and detect typical signs of drowsiness, such as involuntary steering movements.

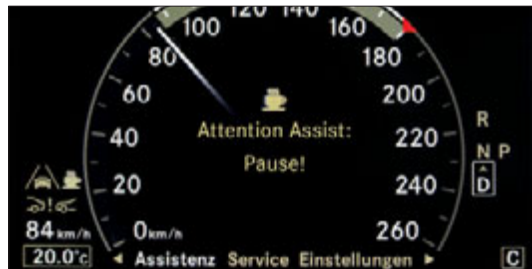

If ATTENTION ASSIST detects signs of drowsiness, it advises the driver to take a break

<sup>1</sup> Not available for S 400 HYBRID

**Adaptive Highbeam Assist** (standard). Adaptive Highbeam Assist ensures excellent visibility at night time too, without dazzling oncoming traffic or vehicles in front. By constantly optimising the headlamp range, it allows the driver to make out the course of the road and identify pedestrians and hazards earlier and more clearly.

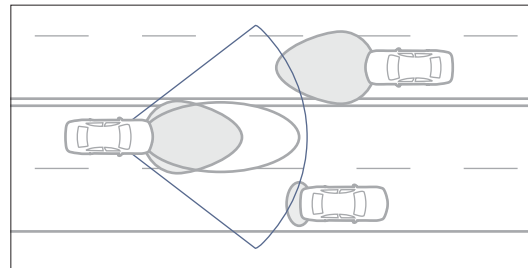

The low-beam headlamps have a range of up to 300 metres with Adaptive Highbeam Assist

**Night View Assist Plus** (optional). This system's infrared camera monitors the entire area normally covered by the high beam and shows it in the instrument cluster as a greyscale image. Furthermore, any persons detected are highlighted too. This makes it easier for drivers to get their bearings at dusk and dawn or in darkness without switching on the high beam, enabling them to react more quickly in dangerous situations.



Night View Assist Plus makes it easier to spot pedestrians ahead

### Driving Assistance package Plus (optional)<sup>2</sup>.

With a subtle vibration on the steering wheel, Active Lane Keeping Assist warns the driver as soon as he or she leaves the recognised, marked lane unintentionally. If the driver fails to react, a lane-correcting brake actuation can occur. The Active Blind Spot Assist ensures increased safety when changing lanes. Two radar sensors observe the area that the driver

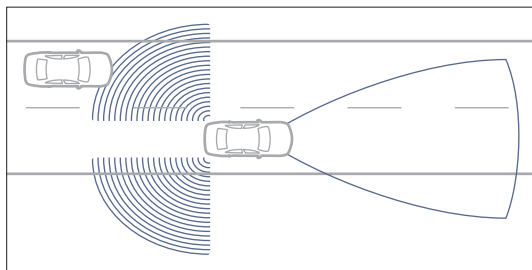

Active Lane Keeping Assist and Active Blind Spot Assist can support the driver in the event of danger

cannot see well in the exterior mirrors – the “blind spot”. If the assistance system detects a vehicle in the danger zone, a red warning triangle lights up in the exterior mirror. If the driver indicates to change lanes and begins to steer, the brakes are applied selectively on one side to warn of the possible danger, thus helping to avoid collisions. DISTRONIC PLUS proximity control uses radar to help the driver maintain a



Active Blind Spot Assist increases safety when changing lanes

preset distance between the car and the vehicle in front, making the driver's job easier in both moving and stop-and-go traffic

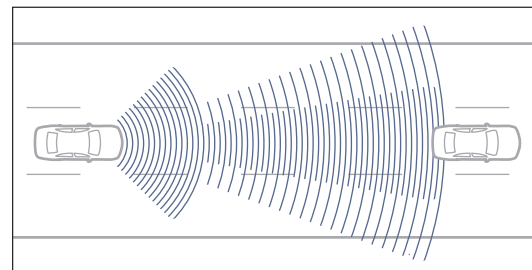

DISTRONIC PLUS proximity control helps the driver maintain the desired distance between the car and the vehicle in front

<sup>2</sup> Only the Driving Assistance package PLUS is available for the S 400 HYBRID

## In the event of danger

Anybody who travels on the road will have to face a dangerous situation sooner or later. That's why a range of systems has been developed for the S-Class to help avoid possible accidents

**PRE-SAFE® Brake and BAS PLUS** (part of the Driving Assistance package). PRE-SAFE® Brake provides the driver first with a visual warning, then an audible alert if a risk of collision is detected. During this phase, BAS PLUS calculates the brake pressure that is required to prevent a collision. If the braking force applied by the driver is not sufficient, then the system automatically increases brake pressure in a way that ensures the remaining braking distance is used to the fullest advantage. This means that the driver of the vehicle behind also has a better chance of avoiding a rear collision.

If the driver fails to respond to the signals, PRE-SAFE® Brake intervenes with autonomous

partial braking, giving the driver a tangible warning. At the same time, the PRE-SAFE® system also triggers other protective measures in preparation for a possible collision. Autonomous

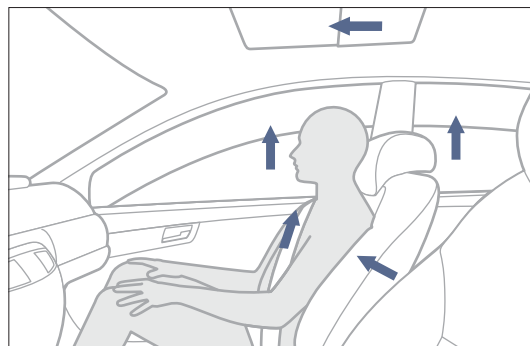

The PRE-SAFE® anticipatory occupant protection system helps to mitigate the consequences of accidents

emergency braking can then be activated if there is still no reaction from the driver. The result is a significant reduction in impact speed and accident severity.

**PRE-SAFE® system** (standard). This anticipatory occupant protection system is able to detect certain critical driving situations in advance and activate preventive measures. If an imminent accident is detected, the system can close the side windows, move the front passenger seat to a more favourable position and tension the front seat belts automatically. It can also close the sliding sunroof and provide lateral support for the occupants in the multicontour seats if the car is fitted with this equipment.

## In an accident

The S-Class provides a safer environment, even in the event of a collision. Multiple protective measures are activated which can help to protect occupants and significantly reduce accident severity

**NECK-PRO head restraints** (standard). The head restraints for the driver and front passenger can be activated by sensor control in a rear impact:

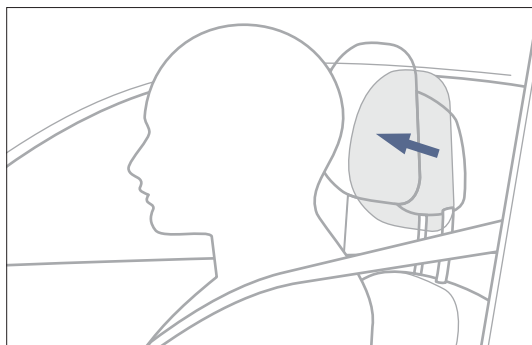

The NECK-PRO head restraints can reduce the risk of whiplash in a rear impact

a spring mechanism moves the head restraints forwards and upwards, providing earlier support for the head and reducing the strain on the spine.



A total of nine airbags can protect you and other car occupants in the event of an accident

**Airbags** (standard). A pioneer of automotive safety, the S-Class was first equipped with a driver's airbag way back in 1981. A front-passenger airbag was added from 1985 onwards, offering even more effective occupant protection. Nowadays the luxury saloon is equipped with nine sophisticated airbags, which can help to prevent or mitigate injuries in the event of a collision. Standard equipment includes two-stage front airbags, sidebags in the seat backrests for the driver and the front passenger as well as windowbags. What's more, the driver can count on an integrated kneebag, which offers additional safety potential in certain situations. Rear sidebags are also included as standard, to protect the rear-seat occupants.

# Light

Sophisticated LED technology enhances the already impressive looks of the S-Class, especially at night. Daytime driving lights are integrated in the front bumper

**Headlamps** (standard). The S-Class is equipped with bi-xenon headlamps. The distinctively shaped turn indicators enhance the car's recognisability. Then there are the new daytime driving lights which, like the front fog lamps, are round and integrated in the bumper.

**Tail lights** (standard). The extensive use of visible LEDs for the indicators, the tail lights and the brake lights gives the tail light clusters a particularly distinctive look. The LED design based on a classic S-Class look enhances visibility for following traffic.

**LED Light package** (optional). The sophisticated technology at the heart of this package gives the S-Class face a highly distinctive look. The LED daytime driving lights – in the form of luminescent strips with chrome surrounds – are integrated on the right and left of the bumper. The turn

indicators and side lights also use LED technology. The package also includes the Intelligent Light System – with its active light function, rural mode, motorway mode, enhanced fog lamps and cornering light function – as well as Adaptive Highbeam Assist.



Tail lights featuring a sophisticated LED design



LED Light package: Intelligent Light System and LED daytime driving lights in the bumper



**Ambient lighting** (optional). This light concept stylishly accentuates the interior design in the dark. Upon opening the door, the driver is met by a welcoming light which makes the interior appear even larger and even more comfortable. When the door is closed, the LED lights are dimmed automatically. For this, the light can be adjusted to one of five possible brightness settings using COMAND. Furthermore, the lighting mood can be varied by selecting one of three colours. Whether it be ice blue (polar), amber (solar) or white (neutral), it's all a matter of personal taste.



The ambient lighting shines as a narrow band of LEDs along the wood trim, the dashboard and all four doors. These lights are dimmable and can be made to come on in one of three different colours

## Multimedia systems

Available in addition to the USB, Bluetooth® and SD card interfaces fitted as standard, SPLITVIEW, the Harman Kardon® Logic 7® surround sound system and the Rear Seat Entertainment package provide outstanding entertainment for every occupant

**COMAND APS** (option in Navigation package). The multimedia system combines telephone, audio, video and hard-disc navigation\*, showing the information on a central colour display. As well as playing video and audio DVDs, the integrated DVD player can also handle CDs and MP3 files. In addition, MUSIC REGISTER enables you store up to 2500 music tracks. Music Search allows you

to search this database based on track title or artist name, for example, so that you can always locate the music you want quickly and easily. The COMAND APS display shows maps – those used by the navigation system, for example – in 3-D.

**SPLITVIEW** (option in Front Seat Entertainment package). SPLITVIEW is an impressive display

technology that allows driver and front passenger to each see a different picture on the same screen. While the driver looks at navigation information, for example, the front passenger can compile their own personal entertainment programme and listen through wireless headphones.



COMAND Controller in the centre console (standard)



SPLITVIEW displays two different images at the same time – for the driver (1) and front passenger (2) – on a single screen

\* Three years of free updates for your map data are already included (vehicle-specific, as of first registration)

**Rear Seat Entertainment package (optional).**

Entertainment for the rear passengers comes courtesy of the Rear Seat Entertainment package, consisting of a DVD player, two 20.3 cm TFT colour displays mounted on the head restraints of the front seats, two sets of radio headphones, remote control and two Aux-in connections. It is therefore possible to watch



Rear screen mounted on the head restraints

films or connect a games console whilst on the road.

Excellent, further optimised sound quality is provided by the Harman Kardon® Logic 7® surround sound system. It combines surround sound in Dolby Digital 5.1, a 13-channel DSP sound amplifier, 14 speakers optimised to suit



The Harman Kardon® Logic 7® 600 W surround sound system: a first-class audio experience

the car interior and a subwoofer. The 3-D sound ensures sheer listening pleasure, whilst the speed-sensitive volume control provides a constant sound impression. What's more, the rear passengers can also control the in-vehicle players and interfaces.

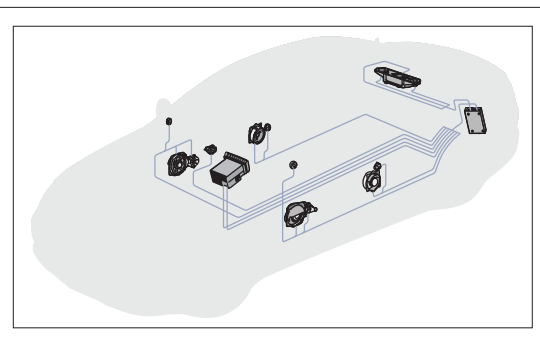

## High-end sound system: Bang & Olufsen BeoSound AMG

High-end surround sound, just like at a live concert – with the sound system specially developed for the S-Class

With the Bang & Olufsen BeoSound AMG high-end sound system from the Danish audio specialist you can actually see as well as hear the perfect acoustics. For the 15 high-performance loudspeakers with a total power of 1200 watts blend

superb technology with an exclusive design. The covers on the subwoofer in the parcel shelf and the mid-range speakers and woofers in matt aluminium in the front and rear doors are a feast for the eyes. And your ears are treated to

the kind of richly layered soundscape you would usually expect in a concert hall rather than a saloon.



With their high-quality design the aluminium Bang & Olufsen loudspeaker covers are a visual delight, too

Four softly illuminated tweeter lenses provide the perfect finishing touches to the visual and acoustic experience. Two of them are positioned in the mirror triangles of the front doors, and two more for the rear seats are situated in the

B-pillars. The sound field can be precisely tuned to the seats in use via the COMAND APS. This ensures that the sound comes into its own everywhere, whether you are driving or being driven. Thanks to the closed boxes, the 15 loudspeakers

produce a specifically defined effect in the interior, whilst at the same time minimising outward acoustic radiation – when telephoning in hands-free mode, for instance.



The illuminated tweeter lenses look especially stunning on night-time journeys



You can adjust the sound to suit your seat position as well as your listening preferences

## Assistance systems

Numerous assistance systems help to enhance ride comfort and make life even easier for the driver of the S-Class



All-round visibility when parking and reversing – thanks to the optionally available reversing camera

**Parking package** (optional). The reversing camera provides assistance to make it easier and safer to park in reverse by affording the driver a better view of the area around the rear of the car. A wide-angle lens is installed below the boot handle. The reversing camera is activated automatically when reverse gear is engaged and registers the area immediately behind the car, sending the image to the COMAND display.

The Parking package also features PARKTRONIC including Parking Guidance. The Parking Guidance system measures parking spaces automatically and helps the driver to find a parking space and to park in it. The data recorded by ultrasonic sensors are used to determine whether a parking space is large enough. The parking

situation is then shown on the multifunction display. Yellow markings on the display indicate the path that needs to be steered, red markings the path that is currently being steered. When the two overlap, they turn green. The PARKTRONIC

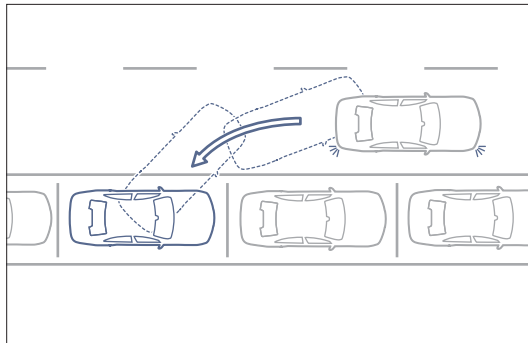

Parking Guidance provides parking instructions

display also indicates the current distance to obstacles.

**Speed Limit Assist** (option in Navigation package). This system can detect speed-limit signs on the

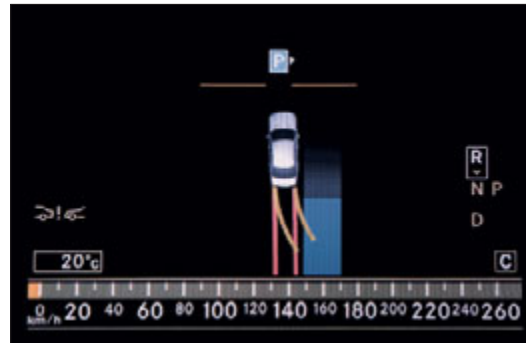

Parking Guidance is easy to use

road and indicate the detected speed limit to the driver on the display. It therefore enhances both safety and convenience, which is of particular benefit on routes with variable speed limits or road works.



Speed Limit Assist display in the instrument cluster

## Climate control

A pleasant interior climate enhances comfort and makes a significant contribution towards a relaxed journey. The standard specification in the S-Class includes four front climate zones, with two rear climate zones available as an option

The automatic climate control system allows the driver and front passenger to adapt the climate in their respective seats to suit their individual



Preferred temperatures can be set individually at the push of a button

requirements – independently of each other. It keeps the temperature at the desired level automatically, even in strong sunlight. To this end,



The optional rear air conditioning

sensors register the temperature inside and outside the S-Class, controlling the heating, cooling and fan for each temperature zone individually, according to requirements. And the airflow can be adjusted in line with individual needs, with a choice of three modes: “diffuse”, “medium” and “focused”.

The front footwell temperature can be adjusted in line with the interior temperature separately (precisely as required, two levels warmer or colder). An activated charcoal filter ensures that only clean air enters the car.

Separate rear air conditioning is available as an option for the two rear zones. A control unit on



the rear face of the centre console allows the rear passengers to set their preferred climate individually. As well as offering an automatic mode, the unit features manual controls with which the air temperature and distribution can be set separately for the left and right sides.

So there's always a pleasant atmosphere inside the S-Class. Not only does this increase comfort levels, it enhances driver concentration too, meaning greater safety for all occupants.

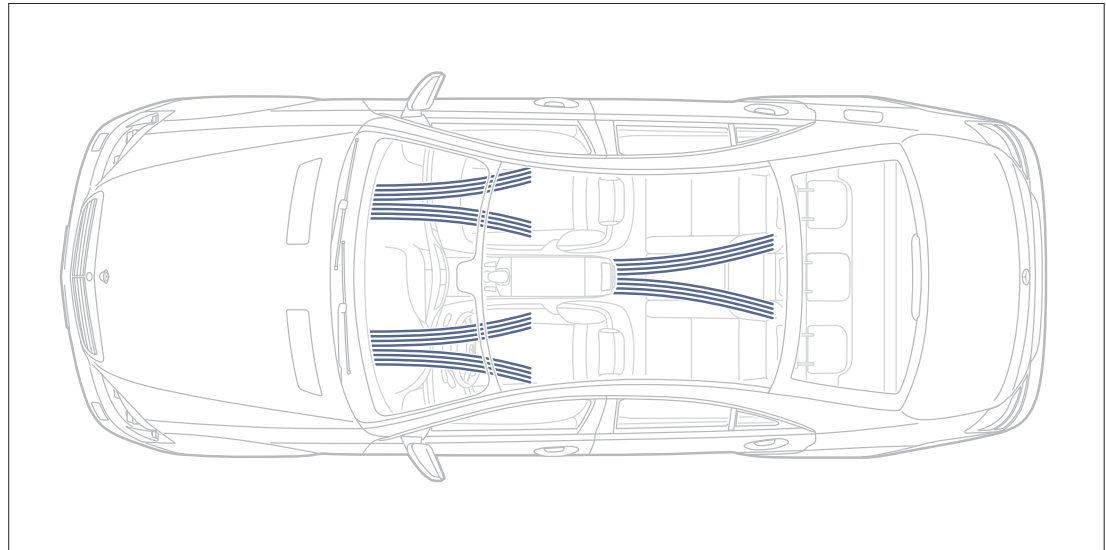

The independently controllable temperature zones in the S-Class

## Seats

The seats in the S-Class meet the very latest requirements in terms of ergonomic design, comfort and safety

**Front Seat Comfort package** (optional). The active multicontour seats with massage and dynamic handling function as well as NECK-PRO luxury head restraints offer the driver and front passenger an exceptional degree of comfort, even on longer trips. A series of air chambers for the lumbar and shoulder areas can be optimised to suit individual body shapes, while the seat's side bolsters adjust automatically and dynamically in line with the car's movements, ensuring excellent support at all times – especially when cornering.

Wellbeing is enhanced by seven massage chambers and four massage programs which use rolling movements to stimulate the back muscles and thus play an active part in helping the occupants to maintain physical fitness.



The active multicontour front seats with a massage and dynamic function



Multicontour rear seats with a massage function

**Rear Seat Comfort package** (optional). Additional comfort in the rear is provided by multicontour seats with a massage function. And safety is enhanced by the luxury head restraints for the outer seats. If the system registers a critical driving situation, the integrated PRE-SAFE® positioning function can move the seats into a more favourable crash position.

**Rear Seat Memory package** (optional). Both outer seats in the rear are optionally electrically adjustable, with a Memory function that allows you to save your preferred seat settings and call them up again at the touch of a button. What's more, the electrically adjustable individual rear seats feature the PRE-SAFE® positioning function.

## Long-wheelbase version

Every amenity for travel, relaxation and work



The long-wheelbase version of the S-Class

A total of 13 centimetres longer than the standard model, the long-wheelbase version<sup>1</sup> of the S-Class more than lives up to its name, as it offers the rear occupants even more legroom. The list of standard equipment and appointments is long too, and includes leather appointments, heated front and rear seats, electrically adjustable outer rear seats, a sliding sunroof, and a blind which can cover the entire rear window.

Optional extras include luxury individual rear seats and the panoramic sliding sunroof as well as manually adjustable folding tables that provide an ideal working environment in the rear.

<sup>1</sup> Available for S 600 and S 65 AMG

The Rear Seat Entertainment package is also available as an option, as is a second handset in



Extra legroom for the rear passengers

the armrest, which also enables calls to be taken by the rear occupants too.



An exclusive ambience for all passengers

## S 600

Well thought-out details and a wealth of comfortable appointments in the S 600<sup>1</sup> make for supremely relaxed motoring

The S 600<sup>1</sup> comes complete with luxurious ex-factory Exclusive PASSION leather appointments. The active multicontour front seats, multicontour rear seats with massage function, door centre panels, centre console and dashboard are trimmed in fine leather, while the A, B and C-pillars are finished in Alcantara® - as is the roof lining with



V12 logo appears in instrument cluster when S 600<sup>1</sup> is fired

<sup>1</sup> Available as long-wheelbase version only

V12 piping. The trim on the doors, dashboard, armrest and steering wheel is available in exclusive poplar wood. KEYLESS-GO and ambient lighting - which can be switched on in one of three colours - are also provided, of course, as is outstanding sound, courtesy of the Harman Kardon® Logic 7® surround sound system. The



Exclusive V12 tailpipes with their vertical rib

latter is part of the standard-fit Entertainment package in the front. Then there is the Navigation package with its hard-disc navigation system forming part of COMAND APS, not to mention PARKTRONIC incl. Parking Guidance and the reversing camera to assist with parking.

The front section of the S 600<sup>1</sup> is dominated by the radiator grille in chrome with three double louvres. Another visual highlight is the standard-fit LED Light package, including the Intelligent Light System, Adaptive Highbeam Assist and LED daytime driving lights plus indicator lamps and side lights with LED technology. Even when it is not moving, the saloon, with its standard-fit light-alloy wheels featuring V12 styling, radiates dynamism. Characteristic traits include the V12 badges on the wings, the tailpipes integrated in the bumper with a vertical rib and chrome trim on the rear bumper.



The front section with its special double-louvre radiator grille in chrome and standard-fit LED front lights

## S-Guard

Outside, S-Class; inside, S-Guard: special protection couldn't be packaged with more class

A world unto itself: the Mercedes-Benz S-Guard. The technology, pioneering comfort and aesthetic appeal of the S-Class combined with comprehensive special protection from Mercedes-Benz Guard. There are good reasons why the S-Guard is indistinguishable from the S-Class at first glance, and second: because it's discreet and inconspicuous.

The S-Guard epitomises the core principles of top-quality, comprehensive ex-factory protection. Perfectly concealed beneath an outer skin that looks identical to that of the series-production model lies a unique combination of craftsmanship and high-tech. Produced in a strictly screened manufacturing facility, the passenger cell incorporates a network of protective components that together form a unique protection system. The chassis, electronic control systems and brake system have all been modified to meet the special requirements of the S-Guard.

Of course, not even an S-Guard is exempt from the usual Mercedes-Benz quality and safety tests – in fact it has to go through even more. Under the watchful eye of independent, internationally recognised institutions, the whole vehicle is subjected to stringent firearms and explosives testing.

The result is a specially protected saloon, ex-factory – the S-Guard.



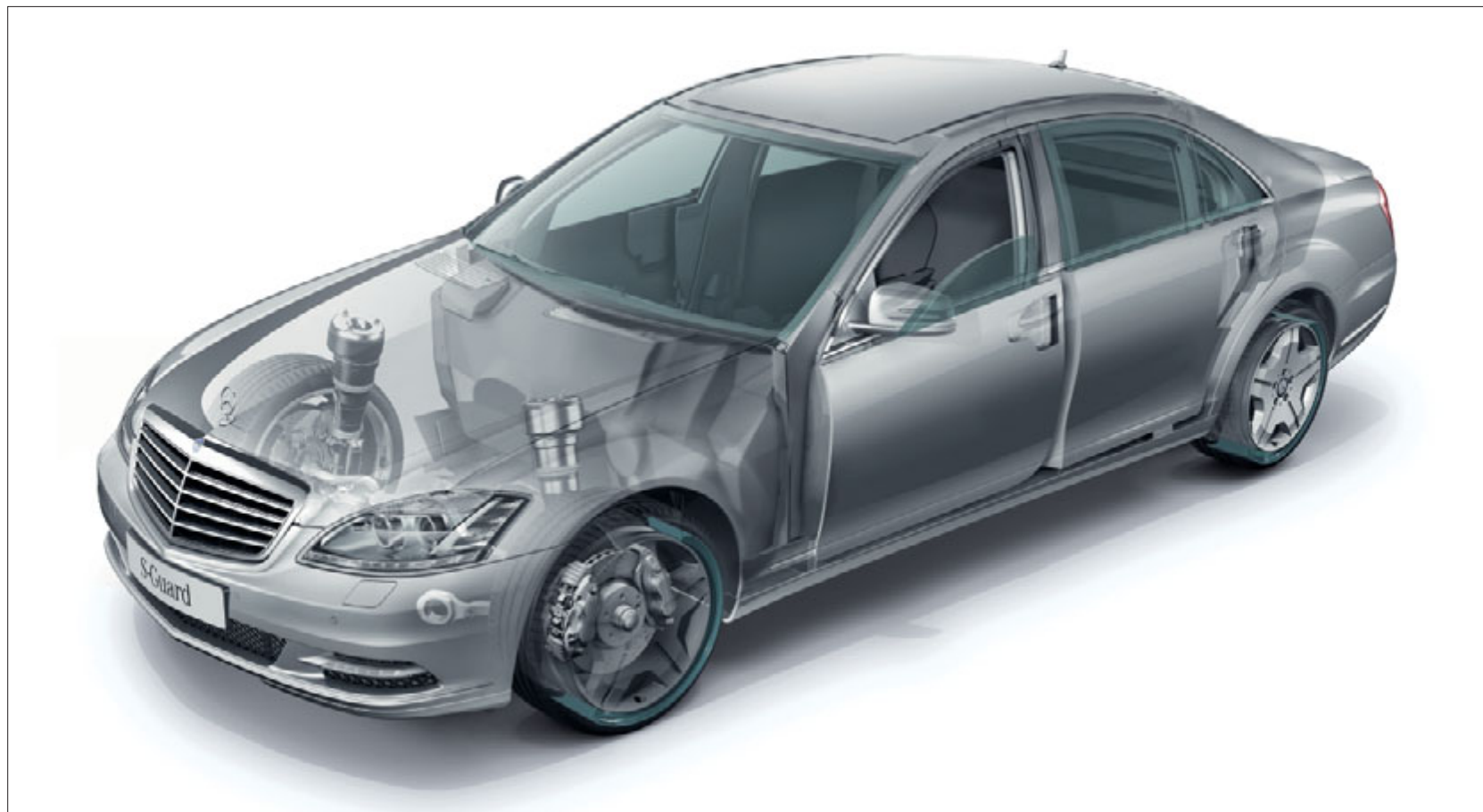

Mobile protection of the highest calibre: the S-Guard offers a degree of safety and quality not achievable by simply retrofitting armour plating

## S 600 Pullman Guard

**A prestigious combination of special luxury and special protection**

Pullman Saloons combine all the attributes of a state limousine ex-factory. They have been inextricably linked with major occasions and prominent personalities for some eight decades. Like the S-Guard, the S 600 Pullman Guard is based

on the “factory-integrated protection” principle. Every last detail has been precisely conceived and designed, developed, tested and certified in such a way that a Pullman is the benchmark. From the protection concept to the 115 cm

longer wheelbase, absolutely everything is fitted “ex-factory” and comes with the Mercedes-Benz brand’s quality promise. The inside of the Pullman invites you to discover an impressive dimension of space. Here you will find every amenity. From



S 600 Pullman Guard – a state limousine offering the highest protection

the integral refrigerated compartment to state-of-the-art communication systems and the exclusive Rear Seat Entertainment System. It can be a mobile office, a worthy and prestigious companion, a discreet meeting room, or a wel-

come retreat. The materials used for the appointments – select woods, exclusive stones, fine leathers and pristine paints – reflect the sheer exclusivity of the Pullman Saloon. The inner qualities are also mirrored on the outside, wher-

ever you look. Its generous dimensions and opulence ensure a stately appearance and elegant comfort.



Comfortable space in an exceptionally generous format: one of the defining characteristics of the S 600 Pullman Guard



Exemplary safety, outstanding comfort, exclusive materials

## S 63 AMG

Dynamism and efficiency → [www.mercedes-amg.com](http://www.mercedes-amg.com)



Performance and efficiency, combined in a luxury-segment saloon: the S 63 AMG

One glance at the exterior of the S 63 AMG and the immense forward thrust of the AMG 5.5-litre V8 biturbo engine with 400 kW at 5250–5750 rpm and a torque of 800 Nm is immediately apparent. The powerful front apron in characteristic AMG guise integrates the LED daytime driving lights,

whilst the diffuser-look rear apron in the vehicle colour is a stand-out feature when viewed from the rear. You can order even more dynamism as an optional extra: 420 kW at 5500 rpm and 900 Nm are at the disposal of your S-Class with the AMG Performance package. And you can

further individualise your AMG vehicle just as you wish in the AMG Performance Studio – with the AMG forged wheels painted in black, for instance.



AMG sports seats upholstered in PASSION leather with an exclusive AMG seat upholstery layout and natural leather in the side bolsters



AMG sports exhaust system with chromed twin tailpipes



AMG forged wheels painted in black (optional)

## S 63 AMG technology

Thrilling experiences at the wheel and maximum efficiency with the AMG 5.5-litre V8 biturbo engine and the AMG SPEEDSHIFT MCT 7-speed sports transmission

**AMG 5.5-litre V8 engine.** The AMG V8 biturbo engine in the S 63 AMG impresses both with its sheer power and its extraordinary efficiency. Up to 420 kW at 5500 rpm and 900 Nm are on tap with the optional AMG Performance package, but with its combined fuel consumption of only 10.5 l/100 km it sets new standards in its segment. This is all thanks to the unique combination of high-tech systems such as direct petrol injection, twin turbocharging, brake energy recuperation and the Controlled Efficiency transmission mode with its start/stop function. And, just as you would expect from an AMG, it boasts a powerful, resonant engine sound.



The AMG 5.5-litre V8 biturbo engine with up to 420 kW and 900 Nm of torque

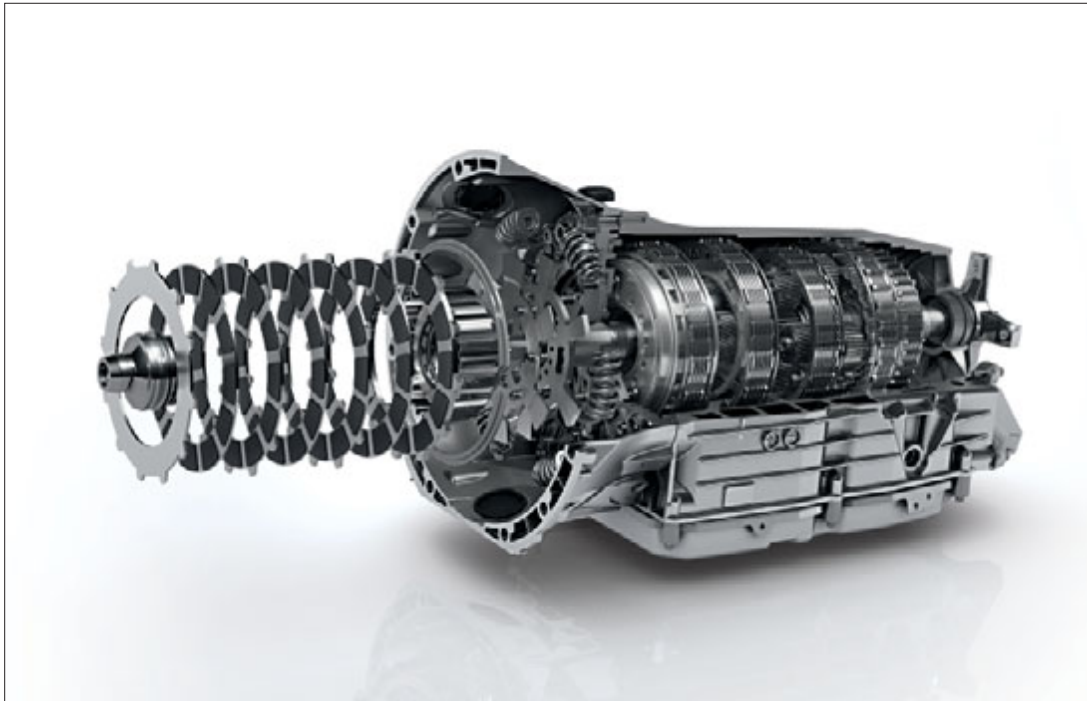

**AMG SPEEDSHIFT MCT 7-speed sports transmission.** The AMG SPEEDSHIFT MCT 7-speed automatic transmission also unites the best of two worlds: the sporty, direct and agile response of a manual transmission and the maximum comfort of an automatic. With the three transmission modes – Controlled Efficiency, Sport and Manual – drivers can decide how dynamically they want to change between the transmission's seven gears. Fast downshifting is a further strength of the AMG MCT sports transmission; via kickdown you can change straight from seventh to fourth gear, for example – the perfect way to exploit the AMG V8 biturbo engine's power to maximum effect.

Fast and easy: changing gear with the AMG SPEEDSHIFT MCT 7-speed sports transmission

## S 65 AMG

The most powerful AMG saloon of all time combines imposing power and exclusive dynamics → [www.mercedes-amg.com](http://www.mercedes-amg.com)



The S 65 AMG<sup>1</sup> underlines its unique standing in the segment for exclusive V12 high-performance saloons



The most powerful S-Class model: the S 65 AMG<sup>1</sup> with an AMG 6.0-litre V12 biturbo engine develops 463 kW at 4600–5000 rpm and achieves a peak torque of 1000 Nm. The result is exhilarating performance – acceleration from 0 to 100 km/h in just 4.4 seconds. Gears can be selected using



The AMG sports steering wheel and the AMG instrument cluster

the DIRECT SELECT lever or Formula 1-style aluminium gearshift paddles on the AMG sports steering wheel. The design is rounded off by an AMG sports exhaust system with two chromed twin tailpipes featuring AMG V12 styling, with twin-spoke AMG forged wheels painted in



AMG trim in black piano lacquer/carbon fibre (optional)

titanium grey providing a further dynamic touch. Optional extras include trim in black piano lacquer/carbon fibre from the AMG Performance Studio.



AMG sports seats in jet black Exclusive designo aniline leather upholstery (optional) with AMG V12 diamond pattern

<sup>1</sup> Available as long-wheelbase version only

## Standard equipment | Selection



Multifunction steering wheel in nappa leather



ATTENTION ASSIST



Telephone keypad



Centre console with COMAND Controller



COMAND colour display



Bluetooth® function in COMAND



Daytime driving lights and front fog lamps with dual circular design



LED tail light

## Optional extras | Selection



Wood/leather steering wheel



KEYLESS-GO



DISTRONIC PLUS



Rear Seat Entertainment package



Active multicontour seats in the front



Boosts safety: Driving Assistance package Plus incl. Active Blind Spot Assist



Harman Kardon® Logic 7® surround sound system



Panoramic sliding sunroof

Some of the illustrated features may show package items

## AMG Sports package

Dynamic styling and a prestigious brand of sportiness

The AMG Sports package injects the S-Class with even more dynamism. It begins on the outside with a powerful-looking AMG front apron and



Trim in high-gloss black ash wood

side sill panels, continuing all the way back to the distinctive AMG rear apron. The impressive look is completed by 5-spoke AMG light-alloy



The distinctive rear apron – part of the AMG Sports package

wheels with a high-shine finish or, as an optional extra, twin-spoke AMG light-alloy wheels.

Further distinguishing features vis-à-vis the standard model include the painted brake callipers with “Mercedes-Benz” lettering and, for the 6-cylinder models, larger front brake discs. There are even more differences inside, including trim in high-gloss black ash. Then there is the wood/leather steering wheel and, finally, the sports pedals in brushed stainless steel and matching AMG floor mats in velour.



The AMG Sports package lends the S-Class a sporty, dynamic aura

# designo

A wealth of high-grade appointments and special details make designo an alluring proposition → [www.mercedes-benz.com/designo](http://www.mercedes-benz.com/designo)

The handcrafted designo range is a source of almost unlimited inspiration with its wide choice of colours, exclusive trim and fine materials.

Even the exterior paintwork can be ordered in one of several additional colours. Moving inside, there is a choice of designo aniline leather or

designo natural leather in various colours. Both versions are also available with exclusive designo leather appointments throughout (see pictures).



Door panel in designo light brown Exclusive aniline leather (X35)



Trim in designo natural maple grain wood (W64)

Plus customers can select from a wide range of stylistically matched wood or stone trim, for example wafer-thin polished granite from Norway or high-gloss black piano lacquer, applied in up to ten coats.

Together with the characteristic seat upholstery layout with ten-rib longitudinal fluting and the designo metal badge in the seat backrests, a designo steering wheel in wood/leather and the roof lining in Alcantara® create an extra-special atmosphere.



Upholstery in designo light brown Exclusive aniline leather (X35) with trim in designo natural maple grain wood (W64)

## designo Selection

Lending the long-wheelbase version of the S-Class an unmistakable character – the designo Selection

→ [www.mercedes-benz.com/designo](http://www.mercedes-benz.com/designo)

High-quality designo appointments add a very personalised touch to the S-Class. And the designo Selection package can help make your decision

easier as it already includes all of the exclusive features. With designo Selection, you can choose any of the available designo exterior paint finishes

(designo metallic, designo mystic or designo magno). In the interior too you can also select any of the available colours for the seat upholstery



Upholstery in designo porcelain Exclusive aniline leather (X27) with trim in designo black piano lacquer (W69)



designo wood/leather steering wheel in black piano lacquer



in designo Exclusive aniline leather. And any of the available designo wood trim along with a matching designo wood/leather steering wheel. Then there is the roof lining in designo black nappa leather with longitudinal fluting as well as an exclusive designo logo in 18-carat solid gold. Whether your preference is for a harmonious colour scheme or a high-contrast combination, the designo Selection is sure to emphasise the exclusivity of your S-Class. To help you make your choice, you can check possible combinations online beforehand, entirely at your leisure. Here you will find a specially designed help function to take you through the numerous options offered by the designo Selection.



designo logo in 18-carat gold



Upholstery in designo porcelain Exclusive aniline leather (X27)



Roof liner in designo black nappa leather with longitudinal-fluting design

## Upholstery and trim

An interior fashioned according to your wishes – with sumptuous wood trim and fine fabric or leather covers



The colour-contrasting topstitching on the glove compartment

**PASSION Leather package.** This high-quality appointments package for the interior comprises seats and armrests in fine leather, a dashboard and door panelling in ARTICO man-made leather – all with colour-contrasting topstitching.

**Exclusive PASSION Leather package.** The optional appointments package refines the PASSION Leather package – the dashboard, door panelling, seatback panels, ruffled pockets and parcel shelf are covered in fine leather with colour-contrasting topstitching. The roof lining plus the A, B and C-pillars all cut an elegant figure in finest Alcantara®.

Both appointments packages have floor mats in velour.

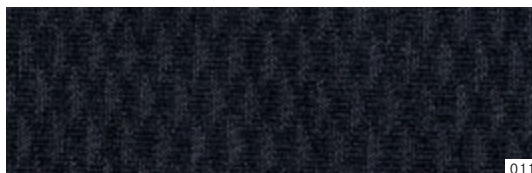

011

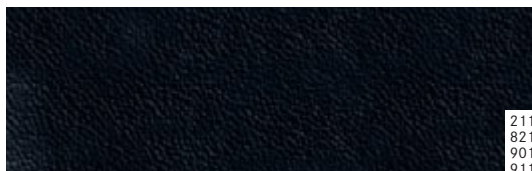
211  
821  
901  
911

H15



731



H14



H18



736

The black colour scheme comes with a choice of seat covers in fabric (standard) or, optionally, leather (standard for long-wheelbase version) or PASSION leather. In this case, the interior (dashboard, steering wheel, centre console, side panels and carpet) is all in black. The Exclusive PASSION Leather variant is optionally available for the long-wheelbase version, in which case the dashboard, door linings, seatback panels, ruffled pockets and parcel shelf are additionally trimmed in PASSION leather. A further elegant touch is provided by the roof lining and the A, B and C-pillars in Alcantara®.

---

**BLACK/BLACK**

---

011 Fabric

211 Leather

821 PASSION leather

U09 PASSION Leather package

901 Exclusive PASSION Leather package

911 Exclusive PASSION Leather package<sup>1</sup>

---

**TRIM**

---

H15 High-gloss dark brown eucalyptus wood<sup>2</sup>

731 High-gloss dark brown burr walnut wood

H14 High-gloss light brown burr walnut wood

H18 High-gloss brown poplar wood<sup>3</sup>

736 High-gloss black ash wood

<sup>1</sup> For V12 only<sup>2</sup> Standard for V6 and V8 only, not for V12<sup>3</sup> Standard for V12 only



The Sahara beige/black colour scheme includes optional leather upholstery (standard for long-wheelbase version) as well as the lower dashboard section, upper centre console section and door interiors in Sahara beige. The upper section of the dashboard, steering wheel, lower section of the centre console, door edges and carpets are finished in black. The same colour combination is available for the optional PASSION Leather or Exclusive PASSION Leather (for the long-wheelbase version) variants. The latter option includes PASSION leather trim for the dashboard, door linings, seatback panels, ruffled pockets and parcel shelf. A further elegant touch is provided by the roof lining and the A, B and C-pillars in Alcantara®.



275  
885  
955  
965



H15

731

H14

H18

736

#### SAHARA BEIGE/BLACK

275 Leather

885 PASSION leather<sup>1</sup>

U09 PASSION Leather package

955 Exclusive PASSION Leather package<sup>1</sup>

965 Exclusive PASSION Leather package<sup>2</sup>

#### TRIM

H15 High-gloss dark brown eucalyptus wood<sup>3</sup>

731 High-gloss dark brown burr walnut wood

H14 High-gloss light brown burr walnut wood

H18 High-gloss brown poplar wood<sup>4</sup>

736 High-gloss black ash wood

<sup>1</sup> Not for S 63 AMG

<sup>2</sup> For S 600 L only

<sup>3</sup> Standard for V6 and V8 only, not for V12

<sup>4</sup> Standard for V12 only



The chestnut brown/black colour scheme includes optional leather upholstery (standard for long-wheelbase version) as well as the lower dashboard section, centre console and door interiors in chestnut brown. The upper section of the dashboard, steering wheel, door edges and carpet are finished in black. The same colour combination is available for the optional PASSION Leather or Exclusive PASSION Leather (for the long-wheelbase version) variants. The latter option includes PASSION leather trim for the dashboard, door linings, seatback panels, ruffled pockets and parcel shelf. A further elegant touch is provided by the roof lining and the A, B and C-pillars in Alcantara®.

---

#### CHESTNUT BROWN/BLACK

---

274 Leather

884 PASSION leather<sup>1</sup>

U09 PASSION Leather package

954 Exclusive PASSION Leather package<sup>1</sup>

964 Exclusive PASSION Leather package<sup>2</sup>

---

#### TRIM

---

H15 High-gloss dark brown eucalyptus wood<sup>3</sup>

731 High-gloss dark brown burr walnut wood

H14 High-gloss light brown burr walnut wood

H18 High-gloss brown poplar wood<sup>4</sup>

736 High-gloss black ash wood

---

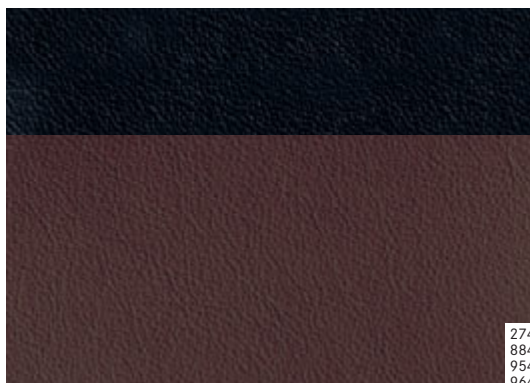

274  
884  
954  
964



H15



731



H14



H18



736

<sup>1</sup> Not for S 63 AMG

<sup>2</sup> For S 600 L only

<sup>3</sup> Standard for V6 and V8 only, not for V12

<sup>4</sup> Standard for V12 only



The alpaca grey/basalt grey colour scheme includes optional leather upholstery (standard for long-wheelbase version) as well as the lower dashboard section, centre console, door interiors and carpets in alpaca grey. The upper section of the dashboard, steering wheel and the door edges are finished in basalt grey. The same colour combination is available in PASSION Leather or Exclusive PASSION Leather (for the long-wheelbase version) as an extra-cost option. The latter option includes PASSION leather trim for the dashboard, door linings, seatback panels, ruffled pockets and parcel shelf. A further elegant touch is provided by the roof lining and the A, B and C-pillars in Alcantara®.

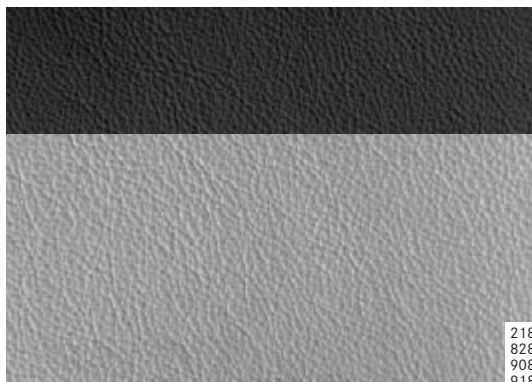

218  
828  
908  
918



H15



731



H14



H18



736

#### ALPACA GREY/BASALT GREY

218 Leather

828 PASSION leather

U09 PASSION Leather package

908 Exclusive PASSION Leather package

918 Exclusive PASSION Leather package<sup>1</sup>

#### TRIM

H15 High-gloss dark brown eucalyptus wood<sup>2</sup>

731 High-gloss dark brown burr walnut wood

H14 High-gloss light brown burr walnut wood

H18 High-gloss brown poplar wood<sup>3</sup>

736 High-gloss black ash wood

<sup>1</sup> For V12 only

<sup>2</sup> Standard for V6 and V8 only, not for V12

<sup>3</sup> Standard for V12 only



The cashmere beige/savanna beige colour scheme includes optional leather upholstery (standard for long-wheelbase version) as well as the lower dashboard section, centre console, door interiors and carpets in cashmere beige. The upper section of the dashboard, steering wheel and door edges are finished in savanna beige. The same colour combination is available in PASSION Leather or Exclusive PASSION Leather (for the long-wheelbase version) as an extra-cost option. The latter option includes PASSION leather trim for the dashboard, door linings, seatback panels, ruffled pockets and parcel shelf. A further elegant touch is provided by the roof lining and the A, B and C-pillars in Alcantara®.

---

#### CASHMERE BEIGE/SAVANNA BEIGE

---

214 Leather

824 PASSION leather

U09 PASSION Leather package

904 Exclusive PASSION Leather package

914 Exclusive PASSION Leather package<sup>1</sup>

---

#### TRIM

---

H15 High-gloss dark brown eucalyptus wood<sup>2</sup>

731 High-gloss dark brown burr walnut wood

H14 High-gloss light brown burr walnut wood

H18 High-gloss brown poplar wood<sup>3</sup>

736 High-gloss black ash wood

---

Further leather appointments and trim are available in the designo range

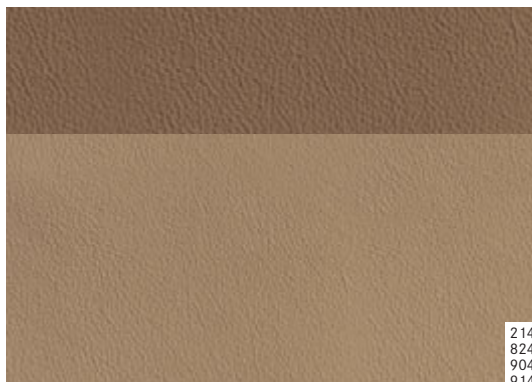

214  
824  
904  
914



H15



731



H14



H18



736

<sup>1</sup> For V12 only

<sup>2</sup> Standard for V6 and V8 only, not for V12

<sup>3</sup> Standard for V12 only

## Wheels



7-spoke light-alloy wheel with 235/55 R 17 tyres (standard for V6 engines)



5-spoke light-alloy wheel with 255/45 R 18 front and 275/45 R 18 rear tyres (standard for V12 engine)



Multi-spoke light-alloy wheel with 255/45 R 18 front and 275/45 R 18 rear tyres (optional extra)



5-spoke light-alloy wheel with 255/45 R 18 tyres (standard for V8 engine)



7-twin-spoke light-alloy wheel with 255/45 R 18 front and 275/45 R 18 rear tyres, high-shine (optional extra)



10-spoke light-alloy wheel with 255/45 R 18 front and 275/45 R 18 rear tyres (optional extra)





5-spoke light-alloy wheel with 255/40 R 19 front and 275/40 R 19 rear tyres (optional extra)



Multi-spoke light-alloy wheel with 255/40 R 19 front and 275/40 R 19 rear tyres (optional extra)



AMG 5-twin-spoke light-alloy wheel with 255/35 R 20 front and 275/35 R 20 rear tyres (optional extra)



5-Y-spoke light-alloy wheels with 255/40 R 19 front and 275/40 R 19 rear tyres (optional extra)



AMG 5-spoke light-alloy wheel with 255/40 R 19 front and 275/40 R 19 rear tyres (AMG Sports package)



incenio "Alaraph" 10-spoke light-alloy wheels<sup>1</sup> for 255/35 R 20 front and 275/35 R 20 rear tyres (accessory wheels available ex-factory)

<sup>1</sup> incenio light-alloy wheels are supplied without tyres

## Genuine accessories

A Mercedes-Benz is more than just a car. It can be a travel companion, an office, a living space. And this diversity is reflected in the Mercedes-Benz genuine accessories range



incenio “Behes” light-alloy wheels<sup>1</sup> for 255/35 R 20 front tyres and 275/35 R 20 rear tyres, bichromatic finish

<sup>1</sup>incenio light-alloy wheels are supplied without tyres

The Mercedes-Benz Genuine Accessories range for the S-Class is designed to make driving even more of an enriching experience. The incenio “Behes” light-alloy wheels are available to further enhance the car’s appearance. The 5-Y-spoke design really catches the eye – whether the car is moving or still.

Refined details such as the high-quality illuminated door sill panels in polished stainless steel with Mercedes-Benz lettering give your S-Class the perfect finishing touch.

It’s easy to transport everything you need for your active leisure time with our rack systems. The New Alustyle basic carrier bars, for instance, allow you to remain flexible when transporting

sports equipment and items of luggage. And you can combine the basic carrier bars with lots of different roof attachments, such as the “Comfort” combined ski and snowboard rack. Its practical pull-out function simplifies loading and unloading.



Illuminated door sill panels with “Mercedes-Benz” lettering

Internet and email on the move: the InCar Hotspot brings the internet to your S-Class. Connect your laptop or up to four other WLAN-capable devices to the internet. Enjoy the advantages of optimum internet access which the InCar



The practical New Alustyle “Comfort” ski and snowboard rack can carry up to six pairs of skis or four snowboards

Hotspot gives you, via a direct connection with the vehicle’s aerial.



Mercedes-Benz InCar Hotspot

## Services

**MercedesCard.** The card is your ticket to the Mercedes-Benz experience. Four times a year, we will send you the Mercedes Magazine, featuring fascinating reports from the world of Mercedes-Benz and articles about our latest vehicles. A MercedesCard also has many other uses too. As a VISA credit card, it is an internationally accepted means of payment. Further benefits are available to provide you with peace of mind, such as insurance packages for your Mercedes and other insurance services for the whole family. Further details can be found at [www.mercedes-benz-bank.de](http://www.mercedes-benz-bank.de)<sup>1</sup>

### **Mercedes-Benz Financial Services.**

Mercedes-Benz stands for quality, innovation and safety – and the same applies to Mercedes-Benz Financial Services. Our innovative leasing and financing products are tailored to your financial needs and means. Once you are on the road in your dream car, our insurance products offer you comprehensive protection on every trip. Our service products also ensure that your car

is always in tip-top condition whilst keeping costs transparent and easily manageable. Your Mercedes-Benz dealer will be glad to go through the latest financial offers and terms and conditions with you.

**Mercedes-Benz mobility.** Your new car comes complete with the promise of feeling safe on the road, but if you should ever need help, then Mercedes-Benz Service24h is there to help. Just call the freephone service hotline on 00800 1 777 7777<sup>2</sup>. The integrated telematics service, Mercedes-Benz Contact<sup>3</sup>, is even more convenient: a touch of a button is all it takes to contact the Mercedes-Benz customer centre. If you wish, relevant vehicle and position-related data is transmitted at the same time, thereby allowing the centre to react quickly and provide rapid on-site assistance. Also standard with your new car at no extra charge is the Mercedes-Benz Mobilo<sup>4</sup> mobility package. Whether you have lost your key, had a breakdown which cannot be repaired immediately or suffered damage to the

vehicle due to an accident or vandalism, Mobilo helps you reach your destination – anywhere in Europe. Whatever is holding you up: you will soon be able to resume your journey.

**Mercedes-Benz Museum.** Experience 125 years of automotive history housed in an architecturally impressive setting. Over 1500 exhibits on nine levels give you an insight into the unique tradition and powers of innovation of the Mercedes-Benz brand in Stuttgart. In an area covering a total of 16,500 square metres, you can see the world's first two automobiles in the shape of the Benz Patent-Motorwagen (motor car) and the Daimler motorised carriage – as well as a glimpse of what the future of Mercedes-Benz holds. We look forward to your visit. Further details can be found at [www.mercedes-benz-classic.com/museum](http://www.mercedes-benz-classic.com/museum)

**Test drive.** The unique feeling of driving a Mercedes cannot be put into words. Which is why we'd like to invite you to experience it

<sup>1</sup> Information about the MercedesCard in Austria and Switzerland can be found on the Mercedes-Benz websites for these countries <sup>2</sup> Alternatively, call +49 69 95 30 72 77. Costs will only be incurred when calling fixed lines from a mobile phone

for yourself by taking a test drive in your dream car. Simply visit [www.mercedes-benz.com](http://www.mercedes-benz.com) to locate your nearest Mercedes-Benz dealer via the “Dealer search” function.

**Interactive Owner’s Manual.** The website also offers an interactive tour, enabling you to acquaint yourself with your dream car. You can view key functions in detail, gain an insight into the car’s inner workings or look at the benefits of each model. For further details, go to [www.mercedes-benz.de/owners-manual](http://www.mercedes-benz.de/owners-manual)

**Mobile internet.** Now you can access the entire world of Mercedes-Benz from your mobile phone. As well as all the passenger car models, there are insights into the entire brand world, a wealth of entertainment offers and direct links to our range of services at [www.mercedes.mobi](http://www.mercedes.mobi)

**Service packages.** Vehicle-specific service packages allow you to safeguard your Mercedes according to your individual needs: for a small monthly

amount, the Excellent Service package covers all service work, including maintenance, wear and tear and repairs, for a period of up to five years. By presenting your Service Card you are therefore protected against unexpected costs. And what's more, you can rely on your Mercedes remaining in tip-top condition for a long time. With the Advance Service package, meanwhile, your Mercedes-Benz can remain in the best of health for even longer. Even after the manufacturer's warranty or Excellent Service package have expired, you are safeguarded against unforeseeable repair costs for a period of up to ten years.



**Accident repairs.** Should the worst happen and you find yourself in need of repairs, with Mercedes-Benz accident repairs you will receive the best possible assistance for your vehicle and ensure that its high-quality safety features are properly maintained. Whether you need paint, body or glass repair work carried out, the highly trained specialists at your Mercedes-Benz service partner will repair your Mercedes-Benz and get you quickly back on the road again.

Your authorised Mercedes-Benz dealer will be pleased to give you more information.



<sup>3</sup> Requires a factory-fitted radio linked up to a switched-on mobile phone. For the cost of a call to the landline network <sup>4</sup> Once the warranty for breakdowns has expired (four years), Mobilo can be extended in periods of one year for a maximum of 30 years, provided that regular maintenance is carried out by your Mercedes-Benz service partner

## Dimensions

### S-Class

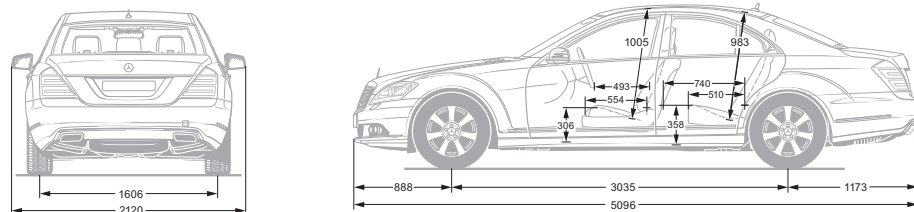

### Long-wheelbase S-Class

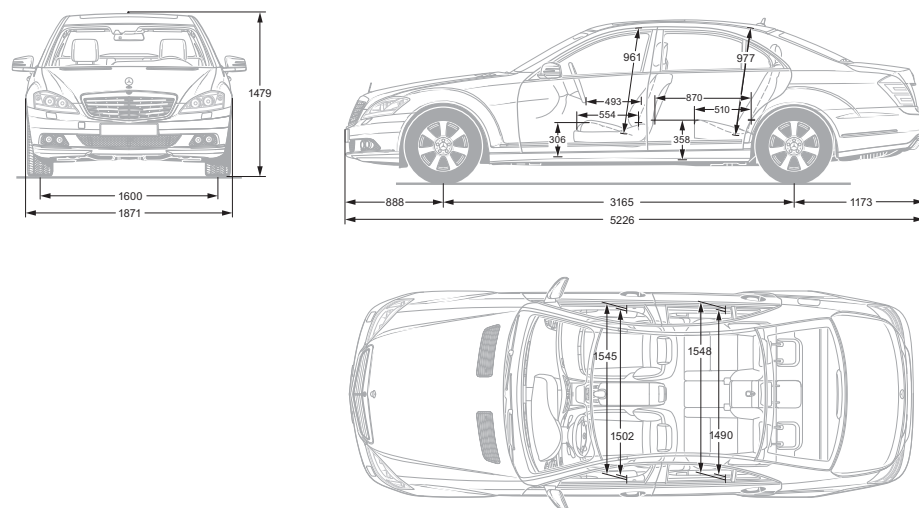

All measurements in millimetres. The dimensions shown are mean values and apply to standard-specification, unladen vehicles

## Paintwork

The special paint system developed by Mercedes-Benz offers one of the best clearcoats on the market. An exceptionally dense molecular structure makes the metallic and non-metallic clearcoats more resistant. The longer-lasting and visibly more intensive shine is a key factor behind the car's excellent value retention.

### NON-METALLIC PAINT (standard)

040 black

### METALLIC PAINTS (optional)

183 magnetite black

197 obsidian black

300 periclase green

370 andorite grey

474 peridot brown

544 carneol red

775 iridium silver

792 palladium silver

890 cavansite blue

### SPECIAL METALLIC PAINTS (optional)

526 dolomite brown

799 diamond white BRIGHT

Further individual paint finishes can be found in the designo range

## Technical data

|   |
|---|
| Arrangement/number of cylinders   |
| Total displacement (cc)   |
| Rated output <sup>1</sup> (kW at rpm)   |
| Rated torque <sup>1</sup> (Nm at rpm)   |
| Compression   |
| Acceleration from 0–100 km/h (s) (long-wheelbase version)                       |
| Top speed approx. (km/h) (long-wheelbase version)                               |
| Tyre size, front  |
| Tyre size, rear   |
| Fuel  |
| Fuel consumption <sup>3</sup> (l/100 km)  |
| Urban (long-wheelbase version)  |
| Extra-urban (long-wheelbase version)  |
| Combined (long-wheelbase version)   |
| CO <sub>2</sub> emissions <sup>3</sup> (g/km) combined (long-wheelbase version) |
| Efficiency class (long-wheelbase version)                                       |
| Emissions standard  |
| Tank capacity (l)/incl. approx. reserve   |
| Boot capacity (l)   |
| Turning circle diameter (m) (long-wheelbase version)                            |
| Kerb weight <sup>4</sup> (kg) (long-wheelbase version)                          |
| Perm. GVW (kg) (long-wheelbase version)   |

### DIESEL ENGINES

| S 250 CDI<br>BlueEFFICIENCY | S 350 BlueTEC                        | S 350 BlueTEC<br>4MATIC              |
|-----------------------------|--------------------------------------|--------------------------------------|
| 4 in-line                   | V6                                   | V6                                   |
| 2143                        | 2987                                 | 2987                                 |
| 150/4200                    | 190/3600                             | 190/3600                             |
| 500/1600–1800               | 620/1600–2400                        | 620/1600–2400                        |
| 16.2                        | 15.5                                 | 15.5                                 |
| 8.2 (8.2)                   | 7.1 (7.1)                            | 7.1 (7.1)                            |
| 240 (240)                   | 250 <sup>2</sup> (250 <sup>2</sup> ) | 250 <sup>2</sup> (250 <sup>2</sup> ) |
| 235/55 R 17                 | 235/55 R 17                          | 235/55 R 17                          |
| 235/55 R 17                 | 235/55 R 17                          | 235/55 R 17                          |
| Diesel                      | Diesel                               | Diesel                               |
| 7.1–7.0 (7.1–7.0)           | 7.9–7.7 (7.9–7.7)                    | 10.1–9.9 (10.1–9.9)                  |
| 5.0 (5.0)                   | 5.6–5.4 (5.6–5.4)                    | 5.9–5.8 (5.9–5.8)                    |
| 5.8–5.7 (5.8–5.7)           | 6.4–6.2 (6.4–6.2)                    | 7.4–7.3 (7.4–7.3)                    |
| 151–149 (151–149)           | 168–164 (168–164)                    | 195–193 (195–193)                    |
| A (A)                       | B (B)                                | C (C)                                |
| Euro 5                      | Euro 6                               | Euro 6                               |
| 83/11                       | 83/11                                | 83/11                                |
| 560                         | 560                                  | 560                                  |
| 11.8 (12.2)                 | 11.8 (12.2)                          | 11.8 (12.2)                          |
| 1970 (2045)                 | 1995 (2060)                          | 2065 (2130)                          |
| 2565 (2625)                 | 2590 (2640)                          | 2660 (2710)                          |

### PETROL ENGINES

| S 350<br>BlueEFFICIENCY              |
|--------------------------------------|
| V6                                   |
| 3498                                 |
| 225/6500                             |
| 370/3500–5250 (3500)                 |
| 12.0                                 |
| 6.9 (7.1)                            |
| 250 <sup>2</sup> (250 <sup>2</sup> ) |
| 235/55 R 17                          |
| 235/55 R 17                          |
| Premium petrol                       |
| 10.6–10.2 (10.7–10.3)                |
| 6.3–6.0 (6.4–6.1)                    |
| 7.9–7.6 (8.0–7.7)                    |
| 184–177 (186–179)                    |
| C (C)                                |
| Euro 5                               |
| 83/11                                |
| 560                                  |
| 11.8 (12.2)                          |
| 1910 (1975)                          |
| 2505 (2555)                          |

<sup>1</sup> Figures in accordance with Directive 80/1269/EEC in the currently applicable version

<sup>2</sup> Electronically governed

<sup>3</sup> The figures shown were obtained in accordance with the prescribed measuring process (Directive 80/1268/EEC in the currently applicable version). The figures are not based on an individual vehicle and do not constitute part of the product offer; they are provided solely for purposes of comparison between different vehicle models

**ALTERNATIVE  
DRIVE SYSTEM  
S 400 HYBRID**

| S 350 4MATIC<br>BlueEFFICIENCY       | S 500<br>BlueEFFICIENCY              | S 500 4MATIC<br>BlueEFFICIENCY       | S 600 <sup>5</sup>    | S 63 AMG   | S 65 AMG <sup>5</sup> |
|--------------------------------------|--------------------------------------|--------------------------------------|-----------------------|--|-----------------------|
| V6                                   | V8                                   | V8                                   | V12                   | V8   | V12                   |
| 3498                                 | 4663                                 | 4663                                 | 5513                  | 5461   | 5980                  |
| 225/6500                             | 320/5250                             | 320/5250                             | 380/5000              | 400/5250-5750 (5500) [420/5500]                          | 463/4600-5000         |
| 370/3500-5250 (3500)                 | 700/1800-3500                        | 700/1800-3500                        | 830/1800-3500         | 800/2000-4500 [900/2250-3750]                            | 1000/2300-4300        |
| 12.0                                 | 10.5                                 | 10.5                                 | 9.0                   | 10.0   | 9.0                   |
| 6.9 (7.1)                            | 5.0 (5.0)                            | 5.0 (5.0)                            | - (4.6)               | 4.5 (4.5) [4.4]  | - (4.4)               |
| 250 <sup>2</sup> (250 <sup>2</sup> ) | 250 <sup>2</sup> (250 <sup>2</sup> ) | 250 <sup>2</sup> (250 <sup>2</sup> ) | - (250 <sup>2</sup> ) | 250 <sup>2</sup> (250 <sup>2</sup> ) [300 <sup>2</sup> ] | - (250 <sup>2</sup> ) |
| 235/55 R 17                          | 255/45 R 18                          | 255/45 R 18                          | 255/45 R 18           | 255/40 ZR 19   | 255/35 ZR 20          |
| 235/55 R 17                          | 255/45 R 18                          | 255/45 R 18                          | 275/45 R 18           | 275/40 ZR 19   | 275/35 ZR 20          |
| Premium petrol                       | Premium petrol                       | Premium petrol                       | Super Plus            | Super Plus   | Super Plus            |
| 10.9-10.8 (10.9-10.8)                | 13.4-12.9 (13.4-12.9)                | 13.8 (13.9)                          | - (21.7-21.5)         | 14.4 (14.4) [14.4]                                       | - (21.8)              |
| 6.7-6.5 (6.7-6.5)                    | 7.4-7.3 (7.4-7.3)                    | 7.6-7.5 (7.7-7.6)                    | - (9.9-9.7)           | 8.2 (8.2) [8.2]  | - (9.9)               |
| 8.3-8.1 (8.3-8.1)                    | 9.6-9.4 (9.6-9.4)                    | 9.8 (9.9)                            | - (14.2-14.1)         | 10.5 (10.5) [10.5]                                       | - (14.3)              |
| 193-189 (193-189)                    | 224-219 (224-219)                    | 229-228 (231-230)                    | (332-329)             | 244 (244) [244]  | - (334)               |
| C (C)                                | E (D)                                | E (E)                                | - (G)                 | E (E) [E]  | - (G)                 |
| Euro 5                               | Euro 5                               | Euro 5                               | Euro 5                | Euro 5   | Euro 5                |
| 83/11                                | 83/11                                | 83/11                                | 90/11                 | 90/14  | 90/14                 |
| 560                                  | 560                                  | 560                                  | 550                   | 560  | 550                   |
| 11.8 (12.2)                          | 11.8 (12.2)                          | 11.8 (12.2)                          | - (12.2)              | 11.8 (12.2) [11.8 (12.2)]                                | - (12.2)              |
| 1980 (2045)                          | 2010 (2075)                          | 2075 (2140)                          | - (2210)              | 2120 (2170)  | - (2275)              |
| 2580 (2630)                          | 2615 (2655)                          | 2685 (2715)                          | - (2690)              | 2670 (2695)  | - (2710)              |

|                                      |
|--------------------------------------|
| V6                                   |
| 3498                                 |
| 205/6000                             |
| 350/3000-5500                        |
| 11.7                                 |
| 7.2 (7.2)                            |
| 250 <sup>2</sup> (250 <sup>2</sup> ) |
| 235/55 R 17                          |
| 235/55 R 17                          |
| Premium petrol                       |
| 10.9-10.7 (11.0-10.8)                |
| 6.5-6.3 (6.6-6.4)                    |
| 8.1-7.9 (8.2-8.0)                    |
| 189-186 (191-188)                    |
| C (C)                                |
| Euro 5                               |
| 90/11                                |
| 560                                  |
| 11.8 (12.2)                          |
| 1955 (2020)                          |
| 2550 (2600)                          |

<sup>4</sup> Figures according to Directive 92/21/EC, version 95/48/EC (kerb weight with fuel tank 90% full, driver, 68 kg, and luggage, 7 kg) for standard-specification vehicles. Optional extras and accessories will generally increase this figure and reduce the payload capacity accordingly <sup>5</sup> Only available as long-wheelbase version Figures in square brackets apply to vehicles with AMG Performance package



## NON-METALLIC PAINT

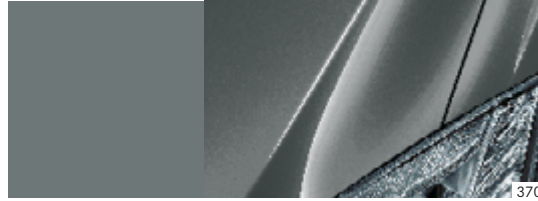

## METALLIC PAINTS

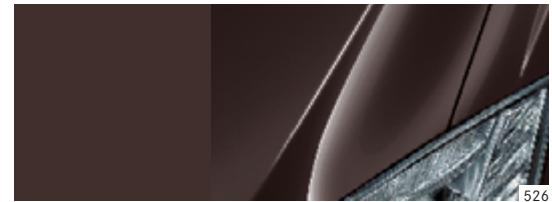
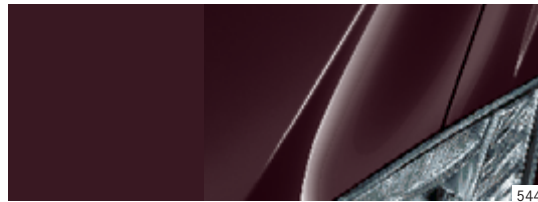
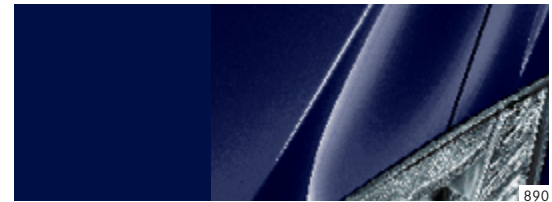

## SPECIAL METALLIC PAINTS



**Take-back of end-of-life vehicles.** Coming full circle. At the end of its long life, you can return your S-Class to us for environmentally-friendly disposal in accordance with the EU End-Of-Life Vehicle Directive<sup>1</sup>. But that day lies a long way off.

<sup>1</sup> Applies in accordance with national regulations to vehicles up to 3.5 tonnes gross weight. Mercedes-Benz passenger cars have met the statutory regulations governing the suitability of their design for reuse and recycling for a number of years now. A network of vehicle take-back depots and dismantlers has been established which will process your vehicle in an environment-friendly manner. The ways in which both vehicles and parts can be recovered are subject to ongoing development and improvement. Consequently, the S-Class will be able to comply with any future increases in the recycling quota within the stipulated time limits. Further information is available at [www.mercedes-benz.com](http://www.mercedes-benz.com)

**Please note:** changes may have been made to the product since this brochure went to press (22.07.2011). The manufacturer reserves the right to make changes to the design, form, colour and specification during the delivery period, provided these changes, while taking into account the interests of the vendor, can be deemed reasonable with respect to the purchaser. Where the vendor or the manufacturer uses symbols or numbers to describe an order or the subject of an order, no rights may be derived solely from these. The illustrations may show accessories and items of optional equipment which are not part of standard specification. Colours may differ slightly from those shown in the brochure, owing to the limitations of the printing process. This brochure is distributed internationally. It provides a general indication of the range of models, features, optional extras and/or colours available in various countries. Some of the models, features, optional extras and/or colours shown may not be available in your country, or may only be available in a different specification. Additionally some models, features, optional extras and/or colours may only be available in combination with others. For current and more specific information in relation to the range of models, features, optional extras and/or colours available in your country, and their pricing, you should contact your nearest authorised Mercedes-Benz Passenger Car Dealer. [www.mercedes-benz.com](http://www.mercedes-benz.com)